

Super-mini Terminal Block Signal Conditioners M5X-UNIT

UNIVERSAL TEMPERATURE TRANSMITTER

(PC programmable)

Functions & Features

- Universal input (T/C and RTD)
- I/O range programming via DIP switch or PC Configurator
- High-density mounting
- Power indicator LED

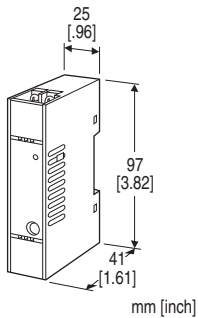

MODEL: M5XTR-1-R[1]

ORDERING INFORMATION

- Code number: M5XTR-1-R[1]
- Specify a code from below for [1].
(e.g. M5XTR-1-R/Q)
- Specify the specification for option code /Q
(e.g. /C01)

INPUT - Field-selectable

Thermocouple

K(CA), E(CRC), J(IC), T(CC), B(RH), R, S, C(WRe 5-26),
D(WRe 3-25), N, U, L

RTD

Pt100 (JIS'97 IEC), Pt500, Pt1000, JPt100 (JIS'89)

EXTERNAL INTERFACE

◆ OUTPUT SIGNAL

- 1: DC output (field-selectable)
- Current output: 0 - 20 mA DC
 - Voltage output: -5 - +5 V DC
 - Voltage output: -10 - +10 V DC

POWER INPUT

DC Power

R: 24 V DC

(Operational voltage range 24 V ±10 %, ripple 10 %p-p max.)

[1] OPTIONS

blank: none

/Q: With options (specify the specification)

SPECIFICATIONS OF OPTION: Q (multiple selections)

COATING (For the detail, refer to M-System's web site.)

/C01: Silicone coating

/C02: Polyurethane coating

/C03: Rubber coating

TERMINAL SCREW MATERIAL

/S01: Stainless steel

EX-FACTORY SETTING

/SET: Preset according to the Ordering Information Sheet
(No. ESU-2764)

RELATED PRODUCTS

- PC Configurator cable (model: COP-US)
 - PC configurator software (model: M5CFG)
- Downloadable at M-System's web site.

GENERAL SPECIFICATIONS

Construction: Terminal block

Connection: M3.5 screw terminals (torque 0.8 N·m)

Screw terminal: Nickel-plated steel (standard) or stainless steel

Housing material: Flame-resistant resin (black)

Isolation: Input to output to power

Cold Junction Compensation (thermocouple input): CJC sensor incorporated

Power Indicator LED: Green LED

Programming: Downloaded from PC;

- input sensor type
- input range
- burn out
- output range
- output limit
- filter time constant (Default setting: 0sec.)
- user's linearization table
- Loop test output

INPUT SPECIFICATIONS

The input type is factory-set to K thermocouple, and the input range to 0 to 100°C.

Input type and accuracy: Refer to table 1

■ Thermocouple input

Input resistance: 1 MΩ min.

Sensor abnormality detection: Burnout (open)

■ RTD (2-wire, 3-wire or 4-wire)

Input resistance: ≥ 1 MΩ

Excitation: 0.3 mA

Allowable leadwire resistance: Max. 20 Ω per wire
Sensor abnormality detection: Burnout or short circuit (≤ 5 Ω)

OUTPUT SPECIFICATIONS

Standard default setting: DC current output 4 - 20 mA, burnout 23 mA

Output type

- DC current output: 0 - 20 mA DC
 - DC voltage output: -10 - +10 V DC
 - DC voltage output: -5 - +5 V DC
- (3 types can be switched by DIP switch and PC)

■ **DC Current:** 0 - 20 mA DC

Output range: 0 - 23 mA DC

Minimum span: 1 mA

Load resistance: 550 Ω

■ DC Voltage

• **Output range -10 - +10 V DC**

Voltage range: -11.5 - +11.5 V DC

Minimum span: 1 V

Load resistance: Output drive 1 mA max.
(ex. 0 - 10 V DC: 10 V ÷ 1 mA = 10 kΩ)

• **Output range -5 - +5 V DC**

Voltage range: -5.75 - +5.75 V DC

Minimum span: 500 mV

Load resistance: Output drive 1 mA max.
(ex. 1 - 5 V DC: 5 V ÷ 1 mA = 5000 Ω)

INSTALLATION

Power consumption

• DC: ≤ 1 W

Operating temperature: -20 to +65°C (-4 to +149°F)

Operating humidity: 30 to 90 %RH (non-condensing)

Weight: 80 g (2.8 oz)

PERFORMANCE in percentage of span

Cold junction compensation error: ±3°C (±5.4°F)

(The described accuracy may be partially not satisfied when the input temperature is below 0°C. Consult factory.)

Temp. coefficient: ±0.0075 %/°C (0.004 %/°F)

Response time: ≤ 1 sec. (0 - 90 %)

Burnout response time: ≤ 1 sec.

Line voltage effect: ±0.1 % over voltage range

Insulation resistance: ≥ 100 MΩ with 500 V DC

Dielectric strength: 2000 V AC @1 minute (input to output to power to ground)

ACCURACY AND CALCULATION EXAMPLES

The accuracy includes input accuracy, which converts the sensor input into a digital value, and output accuracy, which

converts the digital value into an analog signal.

The accuracy of the device is the total of the input accuracy and the output accuracy

Input accuracy

Accuracy of each input is as table 1.

For RTD, the table or ±0.05% of setting value span, whichever is greater.

For thermocouple, add CJC error 3 °C to the above.

Output accuracy

Output accuracy for the setting value span is shown as following formula.

Output accuracy = (output range ÷ output setting value span) × 0.02%

For current output,

Output accuracy = (output range ÷ output setting value span) × 0.04%

Calculation examples

Ex1: RTD Pt100 0 to 500°C, output 4 to 20 mA

Input accuracy = 0.15°C ÷ 500°C = 0.03%

0.03% < 0.05% -> input accuracy is 0.05%

Output accuracy = (20 mA ÷ 16A) × 0.04% = 0.05%

Total accuracy = input accuracy 0.05% + output accuracy 0.05% = 0.1 %

EX2: K thermocouple 0 to 700 °C, output 0 to 10 V

Input accuracy = 0.5°C + CJC error 3°C = 3.5°C

3.5°C ÷ 700°C = 0.5%

Output accuracy = (20 V ÷ 10 V) × 0.02% = 0.04%

Total accuracy = input accuracy 0.5% + output accuracy 0.04% = 0.54%

STANDARDS & APPROVALS

EU conformity:

EMC Directive

EMI EN 61000-6-4

EMS EN 61000-6-2

RoHS Directive

INPUT TYPE, RANGE & CONVERSION ACCURACY

[Table1]

Thermocouple	°C			°F		
	Minimum Span	Input Range	Input Accuracy	Minimum Span	Input Range	Input Accuracy
K (CA)	50	-180 to +1372	±0.5	90	-292 to +2501	±0.9
E (CRC)	50	-100 to +1000	±0.5	90	-148 to +1832	±0.9
J (IC)	50	-100 to +1200	±0.5	90	-148 to +2192	±0.9
T (CC)	50	-200 to +400	±0.5	90	-328 to +752	±0.9
B (RH)	100	400 to 1820	±1 ¹	180	752 to 3308	±1.8 ¹
R	100	-50 to +1760	±1 ²	180	-58 to +3200	±1.8 ²
S	100	-50 to +1760	±1 ²	180	-58 to +3200	±1.8 ²
C (WRe 5-26)	100	0 to 2300	±1	180	32 to 4172	±1.8
D (WRe 5-25)	100	0 to 2300	±1	180	32 to 4172	±1.8
N	50	-180 to +1300	±0.5	90	-292 to +2372	±0.9
U	50	-200 to +600	±0.5	90	-328 to +1112	±0.9
L	50	-100 to +900	±0.5	90	-148 to +1652	±0.9

RTD	°C			°F		
	Minimum Span	Input Range	Input Accuracy ³	Minimum Span	Input Range	Input Accuracy ³
Pt100 (JIS'97, IEC)	1.0	-200 to +850	±0.15	18	-328 to +1562	±0.27
Pt500	1.0	-200 to +850	±0.15	18	-328 to +1562	±0.27
Pt1000	1.0	-200 to +850	±0.15	18	-328 to +1562	±0.27
JPt100 (JIS'89)	1.0	-200 to +510	±0.15	18	-328 to +950	±0.27

*1. Input Range 400 to 850°C (752 to 1562°F) 2°C (3.6°F)

*2. Input Range -50 to +100°C (-58 to +212°F) 2°C (3.6°F)

*3. Input Accuracy of RTD: Or ±0.05% of span whichever is greater.

EXTERNAL VIEW

■ LEFT VIEW

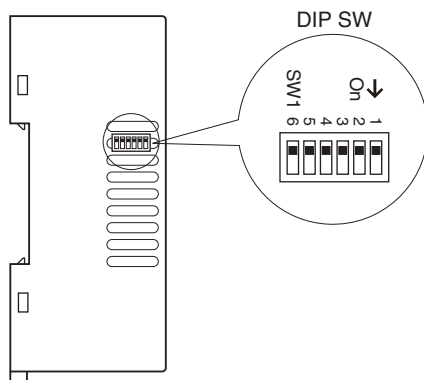

■ FRONT VIEW

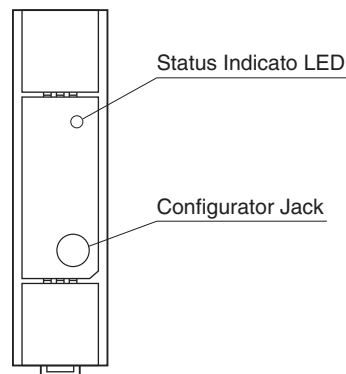

EXTERNAL DIMENSIONS & TERMINAL ASSIGNMENTS unit: mm [inch]

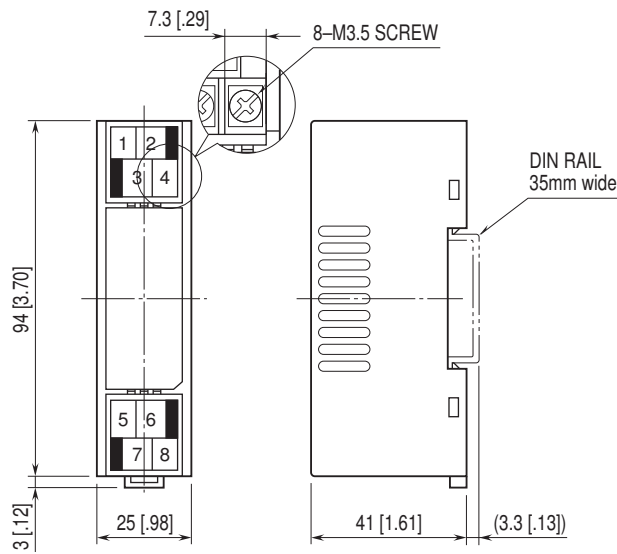

• When mounting, no extra space is needed between units.

SCHEMATIC CIRCUITRY & CONNECTION DIAGRAM

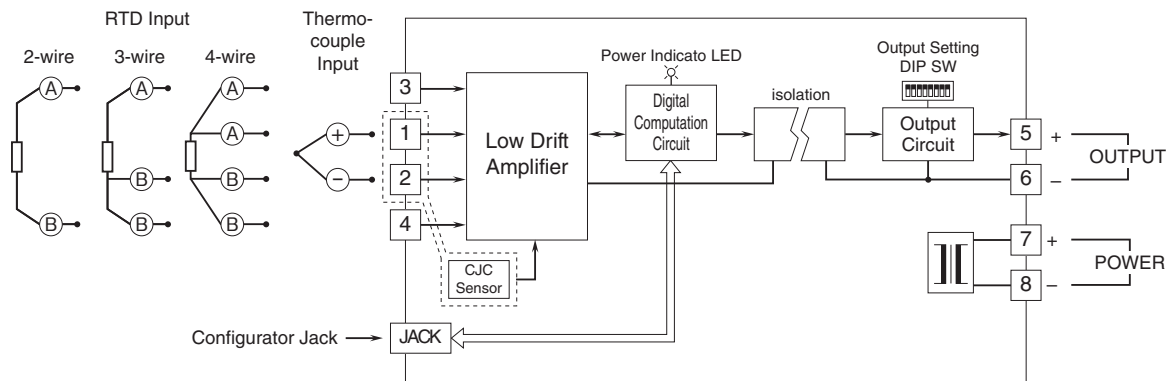

Specifications are subject to change without notice.