

## Super-mini Terminal Block Signal Conditioners M5-UNIT

### SIGNAL TRANSMITTER

(high speed response)

#### Functions & Features

- Converts a DC input into an isolated DC signal
- Ultra-high speed response 150  $\mu$ sec.
- High-density mounting
- Power LED

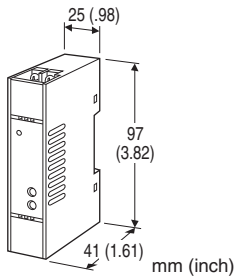

### MODEL: M5VF-[1][2]-[3][4]

#### ORDERING INFORMATION

- Code number: M5VF-[1][2]-[3][4]
- Specify a code from below for each of [1] through [4].  
(e.g. M5VF-4W4W-R/Q)
- Special input and output ranges (For codes Z & 0)
  - Specify the specification for option code /Q  
(e.g. /C01/V01/S01)

#### [1] INPUT

##### Current

- A: 4 - 20 mA DC (Input resistance 249  $\Omega$ )
- B: 2 - 10 mA DC (Input resistance 499  $\Omega$ )
- C: 1 - 5 mA DC (Input resistance 1000  $\Omega$ )
- D: 0 - 20 mA DC (Input resistance 49.9  $\Omega$ )
- E: 0 - 16 mA DC (Input resistance 61.9  $\Omega$ )
- F: 0 - 10 mA DC (Input resistance 100  $\Omega$ )
- G: 0 - 1 mA DC (Input resistance 1000  $\Omega$ )
- H: 10 - 50 mA DC (Input resistance 20  $\Omega$ )
- Z: Specify current (See INPUT SPECIFICATIONS)

##### Voltage

- 3: 0 - 1 V DC (Input resistance 1 M $\Omega$  min.)
- 4: 0 - 10 V DC (Input resistance 1 M $\Omega$  min.)
- 5: 0 - 5 V DC (Input resistance 1 M $\Omega$  min.)
- 6: 1 - 5 V DC (Input resistance 1 M $\Omega$  min.)
- 4W: -10 - +10 V DC (Input resistance 1 M $\Omega$  min.)
- 5W: -5 - +5 V DC (Input resistance 1 M $\Omega$  min.)
- 0: Specify voltage (See INPUT SPECIFICATIONS)

#### [2] OUTPUT

##### Current

- A: 4 - 20 mA DC (Load resistance 550  $\Omega$  max.)
- Z: Specify current (See OUTPUT SPECIFICATIONS)  
(Not selectable with the power input code M)

##### Voltage

- 4: 0 - 10 V DC (Load resistance 1000  $\Omega$  min.)
- 5: 0 - 5 V DC (Load resistance 500  $\Omega$  min.)
- 6: 1 - 5 V DC (Load resistance 500  $\Omega$  min.)
- 4W: -10 - +10 V DC (Load resistance 8000  $\Omega$  min.)
- 5W: -5 - +5 V DC (Load resistance 4000  $\Omega$  min.)
- 0: Specify voltage (See OUTPUT SPECIFICATIONS)  
(Not selectable with the power input code M)

#### [3] POWER INPUT

##### AC Power

- M: 85 - 264 V AC (Operational voltage range 85 - 264 V, 47 - 66 Hz)  
(CE or UKCA not available)

##### DC Power

- R: 24 V DC  
(Operational voltage range 24 V  $\pm$ 10 %, ripple 10 %p-p max.)

#### [4] OPTIONS

- blank: none
- /Q: With options (specify the specification)

#### SPECIFICATIONS OF OPTION: Q (multiple selections)

##### COATING (For the detail, refer to M-System's web site.)

- /C01: Silicone coating
- /C02: Polyurethane coating
- /C03: Rubber coating

##### ADJUSTMENT

- /V01: Multi-turn fine adjustment

##### TERMINAL SCREW MATERIAL

- /S01: Stainless steel

**GENERAL SPECIFICATIONS**

**Construction:** Terminal block  
**Connection:** M3.5 screw terminals (torque 0.8 N·m)  
**Screw terminal:** Nickel-plated steel (standard) or stainless steel  
**Housing material:** Flame-resistant resin (black)  
**Isolation:** Input to output to power  
**Overrange output:** Approx. -10 to +110 % at 1 - 5 V  
**Zero adjustment:** -2 to +2 % (front)  
 (±1 % with the input suffix codes 4W and 5W selected)  
**Span adjustment:** 98 to 102 % (front)  
 (99 to 101 % with the input suffix codes 4W and 5W selected.)  
**Power indicator LED:** Green LED turns on when the power is supplied.

**INPUT SPECIFICATIONS**

■ **DC Current:** Input resistor incorporated  
 Specify input resistance value among followings for code Z.  
 20Ω, 49.9Ω, 61.9Ω, 100Ω, 249Ω, 499Ω, 1000Ω  
 ( $0.125 \text{ W} \geq [\text{Input current}]^2 \times R$ )  
 ■ **DC Voltage:** -30 - +30 V DC  
**Minimum span:** 1 V  
**Offset:** Max. 1.5 times span  
**Input resistance:** 1 MΩ min.  
 (10 kΩ min. at power loss)

**OUTPUT SPECIFICATIONS**

■ **DC Current:** 0 - 20 mA DC  
**Minimum span:** 1 mA  
**Offset:** Max. 1.5 times span  
**Load resistance:** Output drive 11 V max.; 9 V max. for the full-scale output < 3 mA  
 ■ **DC Voltage:** 0 - 10 V DC  
**Minimum span:** 1 V  
**Offset:** Max. 1.5 times span  
**Load resistance:** Output drive 10 mA max.; at ≥ 1 V

**INSTALLATION**

**Power Consumption**  
 •AC:  
 Approx. 2 VA at 100 V  
 Approx. 2 VA at 200 V  
 Approx. 3 VA at 264 V  
 •DC: Approx. 2 W  
**Operating temperature:** -5 to +55°C (23 to 131°F)  
**Operating humidity:** 0 to 90 %RH (non-condensing)  
**Mounting:** DIN rail  
**Weight:** 80 g (2.8 oz)

**PERFORMANCE in percentage of span**

**Accuracy:** ±0.1 %  
**Temp. coefficient:** ±0.015 %/°C (±0.008 %/°F)  
 ±0.02 %/°C (±0.01 %/°F) with AC power  
**Response time:** ≤ 150 μsec. (0 - 90 %)  
**Line voltage effect:** ±0.1 % over voltage range  
**Insulation resistance:** ≥ 100 MΩ with 500 V DC  
**Dielectric strength** (input to output to power to ground)  
**DC powered:** 2000 V AC @1 minute  
**AC powered:** 1500 V AC @1 minute

**STANDARDS & APPROVALS**

**EU conformity:**  
 EMC Directive  
 EMI EN 61000-6-4  
 EMS EN 61000-6-2  
 RoHS Directive  
**UK conformity (UKCA):**  
 The UK legislations and designated standards are equivalent to the applicable EU directives.  
 (Refer to M-System's website for more information about the legislations and designated standards.)

**FRONT VIEW**

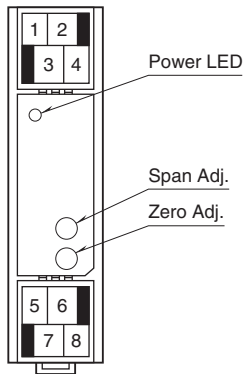

**EXTERNAL DIMENSIONS & TERMINAL ASSIGNMENTS unit: mm [inch]**

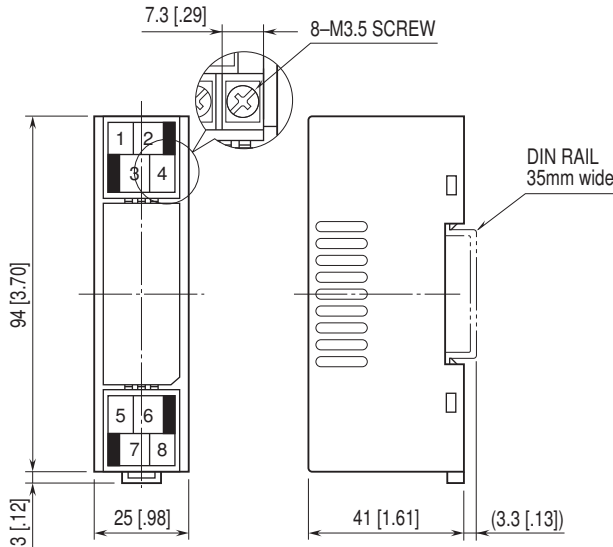

• When mounting, no extra space is needed between units.

**SCHEMATIC CIRCUITRY & CONNECTION DIAGRAM**

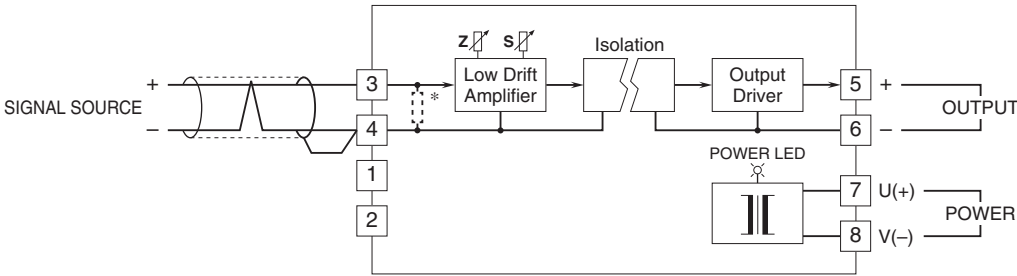

\*Input shunt resistor incorporated for current input.

The M5VF, by its fast-response feature, is not designed to eliminate noise present in the input signal. Use a shielded twisted-pair cable for preventing noise entering through the input wiring.

 Specifications are subject to change without notice.