

Hybrid IC Isolation Amplifiers 20 Series

ISOLATION AMPLIFIER

(high-accuracy, input isolation)

Functions & Features

- Being used for printed wiring board installation
- Up to 1000 V isolation between input to output or power input
- High-linearity
- Small installation area in printed wiring board
- Gain adjustable range, $\times 1$ to $\times 10$
- Power 15 V DC

Typical Applications

- Isolating the field and input circuit of microprocessor to reduce noise from field
- Available for manufacturers of small-lot products to omit the development of isolation circuit

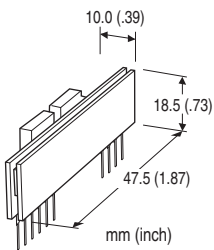

MODEL: 20VS5251-U

ORDERING INFORMATION

- Code number: 20VS5-251-U

INPUT RANGE -10 - +10 V DC

OUTPUT RANGE -10 - +10 V DC

POWER INPUT

DC Power

U: 15 V DC

GENERAL SPECIFICATIONS

Construction: Hybrid IC

Isolation: Input or reference voltage source to output or power supply

INPUT SPECIFICATIONS

■ **DC Voltage**

Input : -10 - +10 V DC

Input resistance: $\geq 1 \text{ M}\Omega$ ($\geq 10 \text{ k}\Omega$ in power failure)

Overload input voltage: 30 V DC continuous

Input offset voltage: $\pm 15 \text{ mV}$

Input bias current: 0.5 nA TYP. (@25°C)

OUTPUT SPECIFICATIONS

■ **DC Voltage:** -10 - +10 V DC

Load resistance: $\geq 5 \text{ k}\Omega$

Output impedance: $\leq 1 \Omega$

REFERENCE VOLTAGE SOURCE

Output voltage: $\pm 15 \text{ V DC TYP.}$

Load current: $\leq 1 \text{ mA}$

INSTALLATION

Power input

- **DC:** Operational voltage range: Rating $\pm 5 \%$, ripple 2 %p-p max.; $\leq 12 \text{ mA}$ with no load

Operating temperature: 0 to 70°C (32 to 158°F)

Operating humidity: 30 to 90 %RH (non-condensing)

Mounting: Soldering to the printed wiring board

Weight: 10g (0.35 oz)

PERFORMANCE in percentage of span

Unless otherwise specified, $G = 1$.

Linearity: $\pm 0.05 \%$

Temp. coefficient: 50 ppm/°C (28 ppm/°F)

Frequency characteristics: Approx. 3 kHz, -3 dB

Response time: $\leq 150 \mu\text{sec.}$ (0 - 90 %)

Conversion gain: $\times 0.98 \pm 2 \%$

Gain adjustable range: $\times 1$ to $\times 10$

Line voltage effect: $\pm 0.05 \%$ over voltage range

Insulation resistance: $\geq 100 \text{ M}\Omega$ with 500 V DC

Dielectric strength: 1000 V AC @ 1 minute

(input or reference voltage source to output or power supply)

CMRR: $\geq 100 \text{ dB}$ (500 V AC 50/60 Hz)

EXTERNAL DIMENSIONS & TERMINAL ASSIGNMENTS unit: mm (inch)

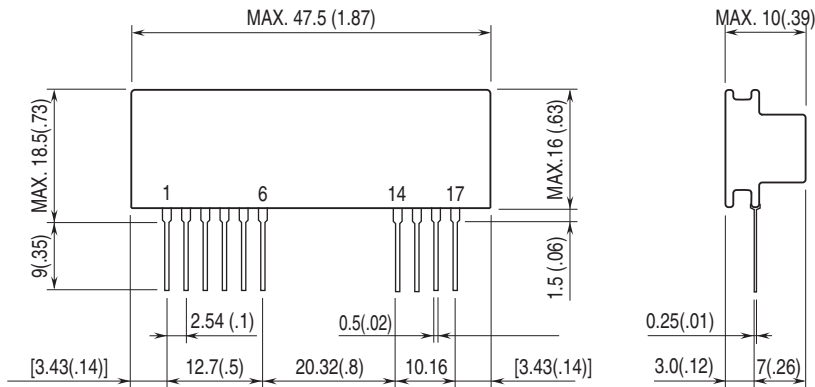

PIN ASSIGNMENT

1	FEEDBACK
2	INVERTING INPUT
3	NON-INVERTING INPUT
4	COM (-)
5	REFERENCE VOLTAGE SOURCE (+)
6	REFERENCE VOLTAGE SOURCE (-)
14	POWER SUPPLY (+)
15	POWER SUPPLY (-)
16	OUTPUT (-)
17	OUTPUT (+)

SCHEMATIC CIRCUITRY & CONNECTION DIAGRAM

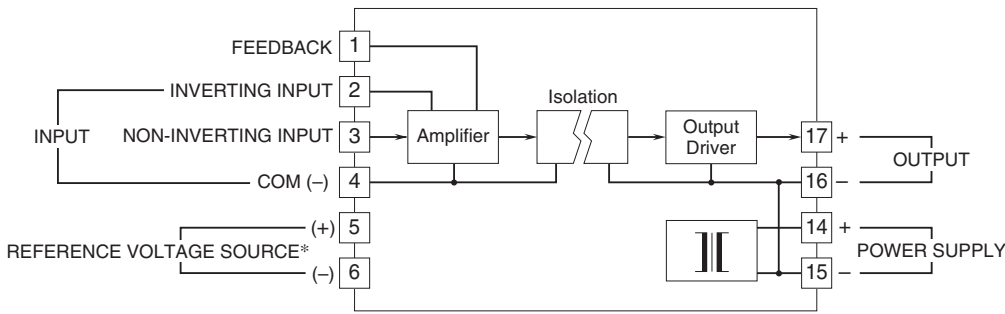

*To be used in the printed wiring board on which the unit is mounted.
Note. The reference voltage source is common to the COM (-), terminal 4.

APPLICATION EXAMPLE

$(R_1 + R_2) \leq 200 \text{ k}\Omega$

■ Non-inverting amplifier circuit: Basic example of $G = 0.98$

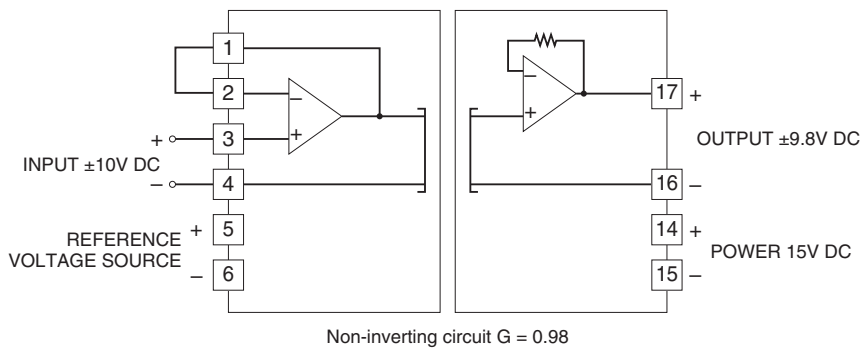

■ Inverting amplifier circuit: Basic example of $G = -1$ (output inverted to the input) ($R_1 \approx R_2$)

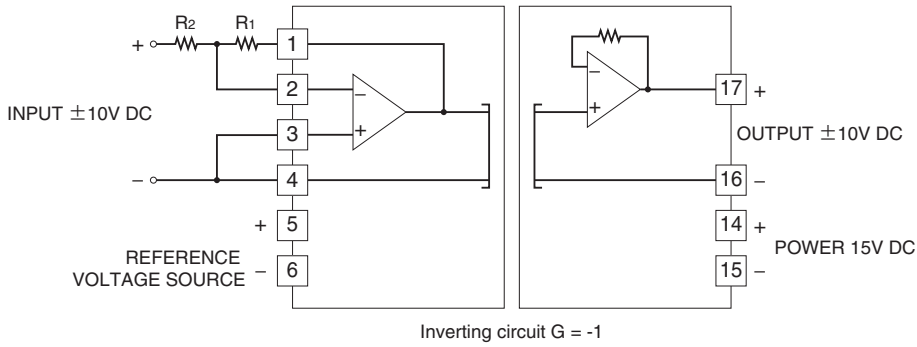

■ Non-inverting amplifier circuit: Example of $G = 1 + R_1 / R_2$

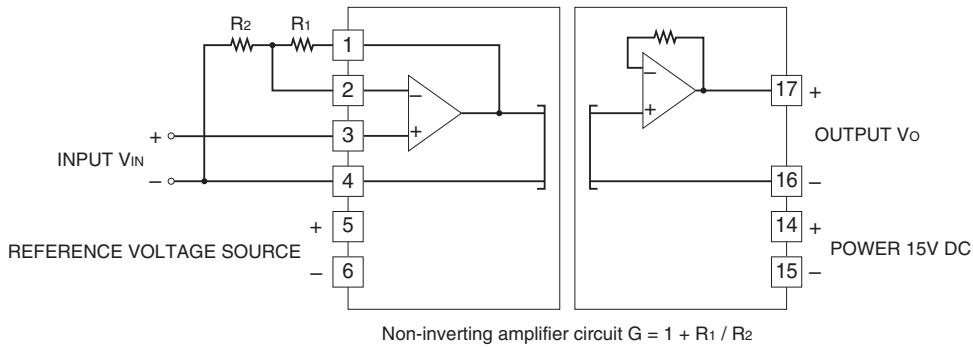

■ Inverting amplifier circuit: Example of $G = -R_1 / R_2$ (output inverted to the input)

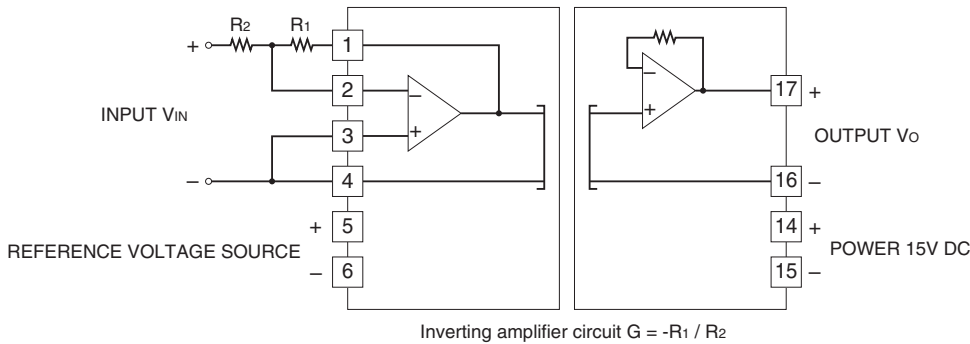

■ Non-inverting amplifier's circuit with external adjustments: Example of $G = 2$

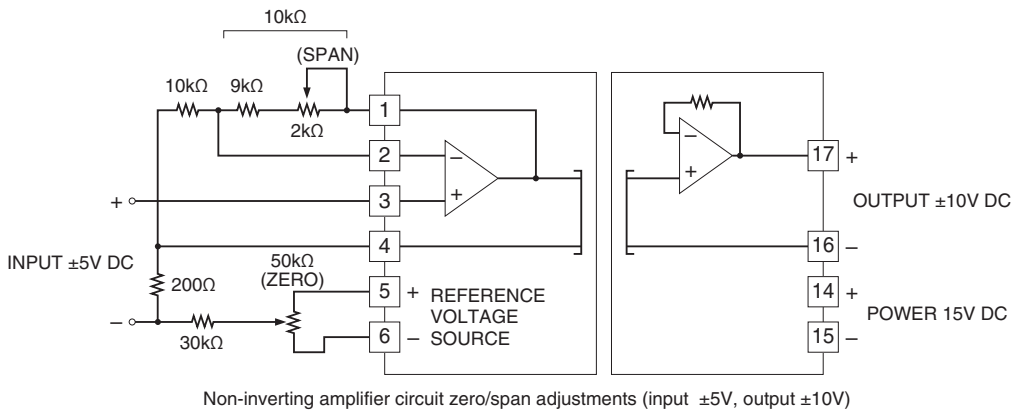

■ Inverting amplifier's circuit with external adjustments: Example of $G = -1$ (output inverted to the input)

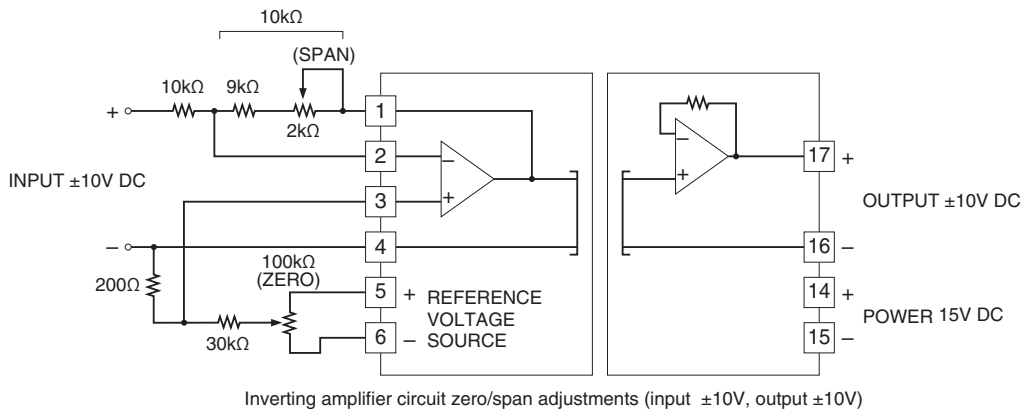

Specifications are subject to change without notice.