

Data sheet MATRIX light guide

Cross-section converter light barrier with silicone protective sleeve for Ex zone 1, 2, 21, 22

Light guides suitable for optical sensors M30 x 1.5. The light guides are mounted with a union nut M30 x 1.5. This is included in the scope of delivery. (Union nut M30 // 20mm)

| Function | Light barrier |
|-----------------------|--|
| Structure | 2-armed |
| Arm lengths | Fixed, cannot be cut to length |
| Fibre | Glass fibre bundle |
| Active area | Fibre bundles mixed or separated |
| Coat | Silicone |
| Bending radius | 50mm |
| Headboard | Steel |
| Operating temperature | -20°C to 120°C |
| Working distance | Dep. on the arm length from the light guide and the sensor performance |
| Light frequency | Preferably infrared |
| Light attenuation | Yes |

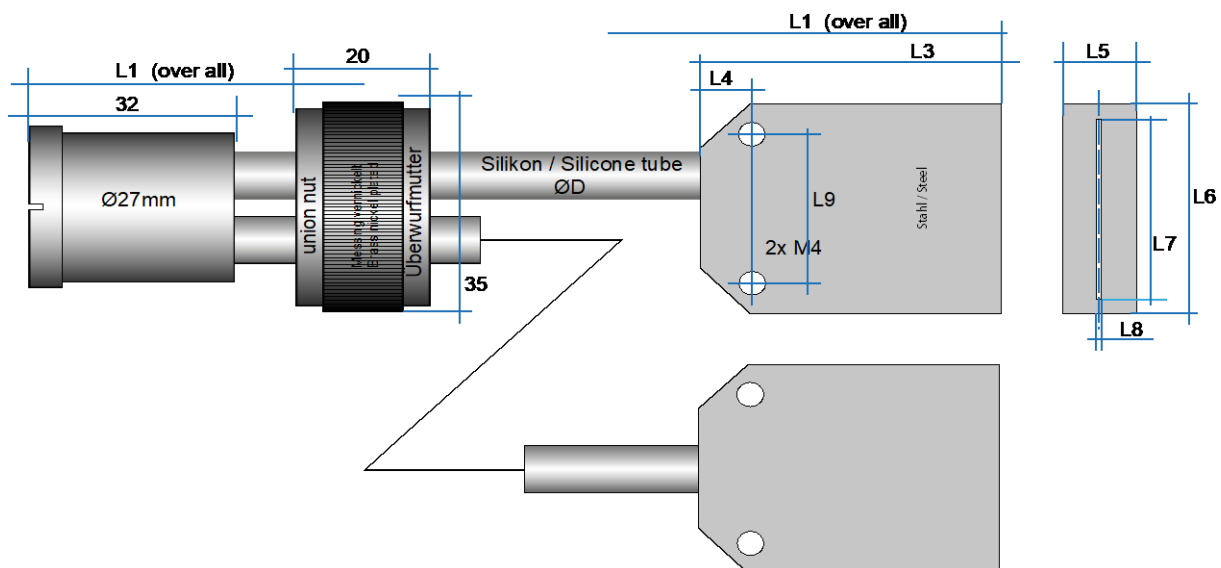

25.11.21/PH

| Active surface approx. 4mm | Dimensions in mm | | | | | | | | | |
|----------------------------|------------------|----|----|-----|----|----|----|-----|----|---|
| | L1 | L2 | L3 | L4 | L5 | L6 | L7 | L8 | L9 | D |
| QWS-0500-04-L-30 | 540 | | 45 | 7,5 | 11 | 35 | 30 | 0,4 | 25 | 8 |
| QWS-1000-04-L-30 | 1040 | | 45 | 7,5 | 11 | 35 | 30 | 0,4 | 25 | 8 |
| QWS-1500-04-L-30 | 1540 | | 45 | 7,5 | 11 | 35 | 30 | 0,4 | 25 | 8 |
| QWS-0500-04-L-60 | 540 | | 70 | 7,5 | 11 | 65 | 60 | 0,2 | 40 | 8 |
| QWS-1000-04-L-60 | 1040 | | 70 | 7,5 | 11 | 65 | 60 | 0,2 | 40 | 8 |
| QWS-1500-04-L-60 | 1540 | | 70 | 7,5 | 11 | 65 | 60 | 0,2 | 40 | 8 |