

Data sheet MATRIX light guide

Cross-section converter light barrier with silicone protective sleeve for Ex zone 1, 2, 21, 22

Light guides suitable for optical sensors M30 x 1.5. The light guides are mounted with a union nut M30 x 1.5. This is included in the scope of delivery. (Union nut M30 // 20mm)

Function	Light barrier (The manufacturer's installation instructions must be observed).
Structure	2-armed
Arm lengths	Fixed, cannot be cut to length
Fibre	Glass fibre bundle
Active area	Fibre bundles mixed or separated
Coat	Silicone
Bending radius	50mm
Headboard	Steel
Operating temperature	-20°C to 120°C
Working distance	Dep. on the arm length from the light guide and the sensor performance
Light frequency	Preferably infrared
Light attenuation	Yes

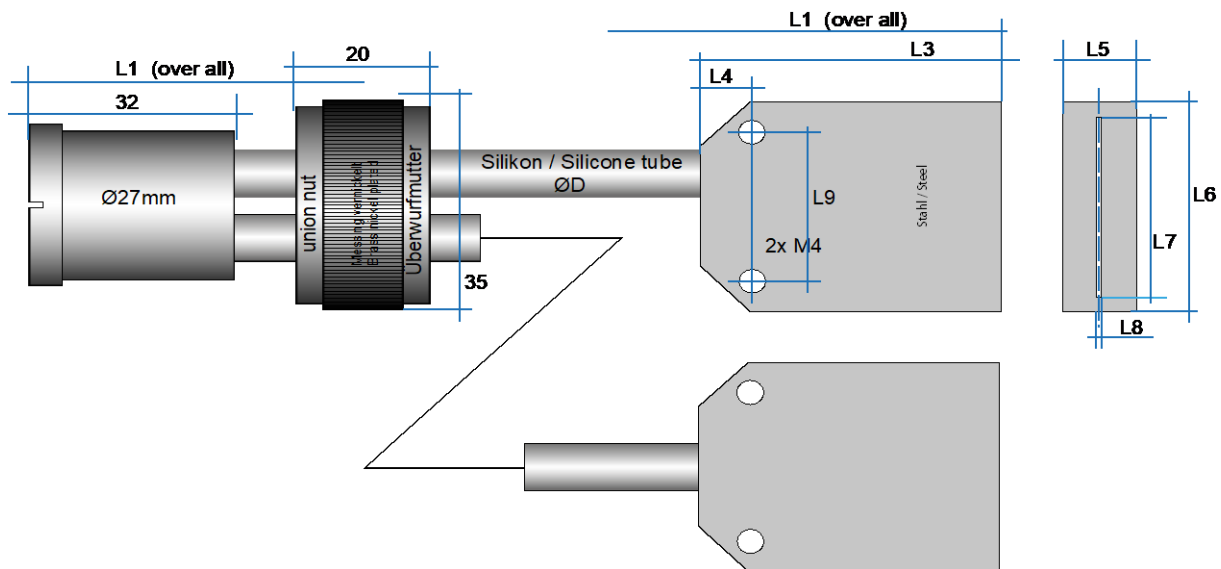

25.11.21/PH

Active surface approx. 4mm	Dimensions in mm									
	L1	L2	L3	L4	L5	L6	L7	L8	L9	D
QWS-0500-04-L-30-OP2	540		45	7,5	11	35	30	0,4	25	8
QWS-1000-04-L-30-OP2	1040		45	7,5	11	35	30	0,4	25	8
QWS-1500-04-L-30-OP2	1540		45	7,5	11	35	30	0,4	25	8
QWS-0500-04-L-60-OP2	540		70	7,5	11	65	60	0,2	40	8
QWS-1000-04-L-60-OP2	1040		70	7,5	11	65	60	0,2	40	8
QWS-1500-04-L-60-OP2	1540		70	7,5	11	65	60	0,2	40	8