

Data sheet MATRIX light guide

Cross-section converter diffuse reflectiv with silicone protective sleeve

Light guides suitable for optical sensors M30 x 1.5. The light guides are mounted with a union nut M30 x 1.5. This is included in the scope of delivery. (Union nut M30 // 20mm)

Function	Diffuse reflectiv
Structure	2-armed
Arm lengths	Fixed, cannot be cut to length
Fibre	Glass fibre bundle
Active area	Fibre bundles mixed or separated
Coat	Silicone
Bending radius	50mm
Headboard	Alu
Operating temperature	-20°C to 120°C
Working distance	Depending on the arm length from the light guide and the sensor performance
Light frequency	Preferably infrared
Light attenuation	Yes

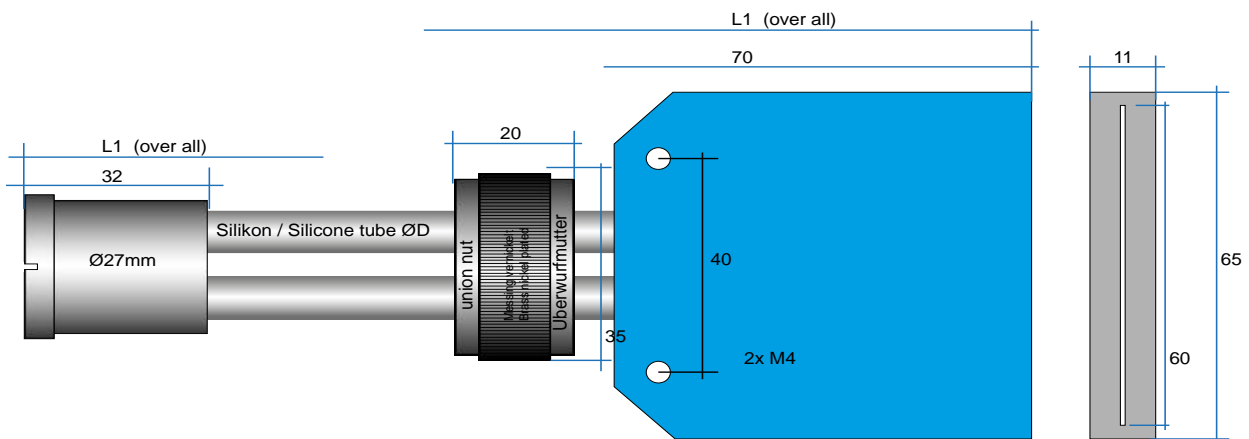

25.11.21/PH

Active surface approx. 4mm^2	Dimensions in mm		
	L1	L2	D
QW-500/4-60-U	570		8
QW-1000/4-60-U	1070		8