

Compact Light Curtain / Type 4
SF4B-□C□

ME-SF4BC No.0053-27V

Thank you very much for purchasing Panasonic products. Read this Instruction Manual carefully and thoroughly for the correct and optimum use of this product. Kindly keep this manual in a convenient place for quick reference.

- This is an abridged instruction manual simply explains mounting, wiring and etc. Kindly refer "our web site (<http://panasonic.net/id/pidsx/global>)" when you need more detail of contents.
- Instruction Manuals in the following languages are published on our Web site. Japanese, English, Chinese, Korean, French, Brazilian Portuguese
 - Le manuel d'instructions français est publié sur notre site web.
 - O Manual de Instruções em Português Brasileiro está publicado em nosso Web site.

1 SAFETY PRECAUTIONS

- Use this device as per its specifications. Do not modify this device since its functions and capabilities may not be maintained and it may malfunction.
- This device has been developed / produced for industrial use only.
- This device is suitable for indoor use only.
- Use of this device under the following conditions or environments is not presupposed. Please consult us if there is no other choice but to use this device in such an environment.
 - 1) Operating this device under conditions or environments not described in this manual.
 - 2) Using this device in the following fields: nuclear power control, railroad, aircraft, auto mobiles, combustion facilities, medical systems, aerospace development, etc.
- When this device is to be used for enforcing protection of a person from any danger occurring around an operating machine, the user should satisfy the regulations established by national or regional security committees (Occupational Safety and Health Administration: OSHA, the European Standardization Committee, etc.). Contact the relative organization(s) for details.
- In case of installing this device to a particular machine, follow the safety regulations in regard to appropriate usage, mounting (installation), operation and maintenance. The users including the installation operator are responsible for the introduction of this device.
- Note that this device may be damaged if it is subject to a strong shock (if it is dropped onto the floor, for example).
- Use this device by installing suitable protection equipment as a countermeasure for failure, damage, or malfunction of this device.
- Before using this device, check whether the device performs properly with the functions and capabilities as per the design specifications.
- In case of disposal, dispose this device as an industrial waste.

⚠ WARNING

- ♦ **Machine designer, installer, employer and operator**
 - The machine designer, installer, employer and operator are solely responsible to ensure that all applicable legal requirements relating to the installation and the use in any application are satisfied and all instructions for installation and maintenance contained in the instruction manual are followed.
 - Whether this device functions as intended to and systems including this device comply with safety regulations depends on the appropriateness of the application, installation, maintenance and operation. The machine designer, installer, employer and operator are solely responsible for these items.
- ♦ **Engineer**
 - The engineer would be a person who is appropriately educated, has widespread knowledge and experience, and can solve various problems which may arise during work, such as a machine designer, or a person in charge of installation or operation etc.
- ♦ **Operator**
 - The operator should read this instruction manual thoroughly, understand its contents, and perform operations following the procedures described in this manual for the correct operation of this device.
 - In case this device does not perform properly, the operator should report this to the person in charge and stop the machine operation immediately. The machine must not be operated until correct performance of this device has been confirmed.
- ♦ **Environment**
 - Do not use a mobile phone or a radio phone near this device.
 - If there exists a reflective surface in the place where this device is to be installed, make sure to install this device so that reflected light from the reflective surface does not enter into the receiver, or take countermeasures such as painting, masking, roughening, or changing the material of the reflective surface, etc. Failure to do so may cause the device not to detect, resulting in death or serious injury.
 - Do not install this device in the following environments.
 - 1) Areas exposed to intense interference (extraneous) light such as high-frequency fluorescent lamp (inverter type), rapid starter fluorescent lamp, stroboscopic lights or direct sunlight.
 - 2) Areas with high humidity where condensation is likely to occur
 - 3) Areas exposed to corrosive or explosive gases
 - 4) Areas exposed to vibration or shock of levels higher than that specified
 - 5) Areas exposed to contact with water
 - 6) Areas exposed to too much steam or dust

- ♦ **Installation**
 - Always keep the correctly calculated safety distance between this device and the dangerous parts of the machine.
 - Install extra protection structure around the machine so that the operator must pass through the sensing area of this device to reach the dangerous parts of the machine.
 - Install this device such that some part of the operator's body always remains in the sensing area when operator is done with the dangerous parts of the machine.
 - Do not install this device at a location where it can be affected by wall reflection.
 - When installing multiple sets of this device, connect the sets and, if necessary, install some barriers such that mutual interference does not occur. For details, refer to "4 DEVICE PLACEMENT."
 - Do not use this device in a reflective configuration.
 - The corresponding emitter and receiver must have the same serial No. and be correctly oriented.

- ♦ **Machine in which this device is installed**
 - When this device is used in the "PSDI Mode," an appropriate control circuit must be configured between this device and the machinery. For details, be sure to refer to the standards or regulations applicable in each region or country.
 - In Japan and China, Korea, do not use this device as safety equipment for a press machine.
 - Do not install this device with a machine whose operation cannot be stopped immediately in the middle of an operation cycle by an emergency stop equipment.
 - This device starts the performance after 2 seconds from the power ON. Use

♦ **Wiring**

- Be sure to carry out the wiring in the power supply OFF condition.
- All electrical wiring should conform to the regional electrical regulations and laws. The wiring should be done by engineer(s) having the special electrical knowledge.
- Do not run the wires together with high-voltage lines or power lines or put them in the same raceway. This can cause malfunction due to induction.
- In case of extending the cable of the emitter or the receiver, each can be extended up to 50m by using the exclusive cable. Extending the cable longer than 50m may cause malfunction, which can result in death or serious injury.
- Do not control the device only at one control output (OSSD 1 / 2).
- In order that the output is not turned to ON due to earth fault of the control output (OSSD 1 / 2) wires, be sure to ground to 0V side (PNP output) / +V side (NPN output).
- When using this device in Korea with S-mark, be sure to ground to 0V side (PNP output).

♦ **Maintenance**

- When replacement parts are required, always use only genuine supplied replacement parts. If substitute parts from another manufacturer are used, the device may not come to detect, result in death or serious injury.
- The periodical inspection of this device must be performed by an engineer having the special knowledge.
- After maintenance or adjustment, and before starting operation, test this device following the procedure specified in "9 MAINTENANCE."
- Clean this device with a clean cloth. Do not use any volatile chemicals.

♦ **Others**

- Never modify this device. Modification may cause the device not to detect, resulting in death or serious injury.
- Do not use this device to detect objects flying over the sensing area.
- Do not use this device to detect transparent objects, translucent objects or objects smaller than the specified minimum sensing objects.

2 CONFIRMATION OF PACKED CONTENTS

- Sensor: Emitter, Receiver 1 pc. each
- Test Rod 1 pc.
SF4B-H□C, SF4B-H□CA-J05: SF4B-TR25 (ø25 x 220mm)
- Quick Instruction Manual (Japanese, English, Chinese, Korean) 1 pc. each language

3 PART DESCRIPTION OF INDICATORS

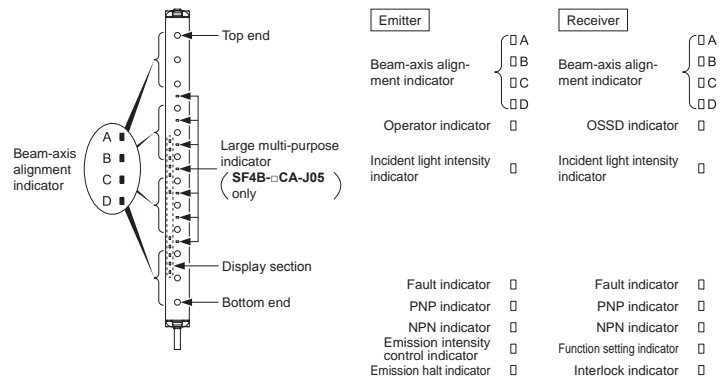

• **Common to emitter and receiver**

Description	Function
Large multi-purpose indicator (Orange) (SF4B-CA-J05 only)	When input for the large multi-purpose indicator is validated: lights up When input for the large multi-purpose indicator is invalidated: OFF
Beam-axis alignment indicator (Red / Green)	A When device top receives light: lights up in red When device top end receives light: blinks in red When control output (OSSD 1 / 2) is ON: lights up in green
	B When device upper middle receives light: lights up in red When control output (OSSD 1 / 2) is ON: lights up in green
	C When device lower middle receives light: lights up in red When control output (OSSD 1 / 2) is ON: lights up in green
	D When device bottom receives light: lights up in red When device bottom end receives light: blinks in red When control output (OSSD 1 / 2) is ON: lights up in green
Incident light intensity indicator (Orange / Green)	When stable light is received: lights up in green When unstable light is received: lights up in orange When light is blocked: OFF
Fault indicator (Yellow)	When fault occurs in the device: lights up or blinks
PNP indicator (Orange)	When PNP output is set: lights up
NPN indicator (Orange)	When NPN output is set: lights up

• **Emitter**

Description	Function
Operator indicator (Red / Green)	Both end beam channels are received: blinks in red All beam channels are received: lights up in green When control output (OSSD 1 / 2) is OFF: lights up in red When control output (OSSD 1 / 2) is ON: lights up in green
Emission intensity control indicator (Orange)	When emission intensity is controlled: lights up
Emission halt indicator (Orange)	When light emission is halt: lights up, When light is emitted: OFF

• **Receiver**

Description	Function
OSSD indicator (Red / Green)	Both end beam channels are received: blinks in red All beam channels are received: lights up in green When control output (OSSD 1 / 2) is OFF: lights up in red When control output (OSSD 1 / 2) is ON: lights up in green
Function setting indicator (Orange)	When connecting the handy controller: blinks When blanking function is used: lights up
Interlock indicator (Yellow)	When device is interlocked: lights up, Other cases: OFF

4 DEVICE PLACEMENT

- This is the configuration when two or more sets of emitter and receiver facing each other are placed. It is used for the case that there is a problem in wiring or for system evaluation in case of addition of equipment. It is used for system evaluation in case of addition of equipment.

⚠ WARNING

- Refer to the examples of device placement given below and understand them thoroughly before installing the devices. Improper sensor placement could cause device malfunction, which can result in death or serious injury.
- If this device is used in multiple sets, arrange them to avoid mutual interference. If mutual interference occurs, it can result in death or serious injury.

<Example of device placement>

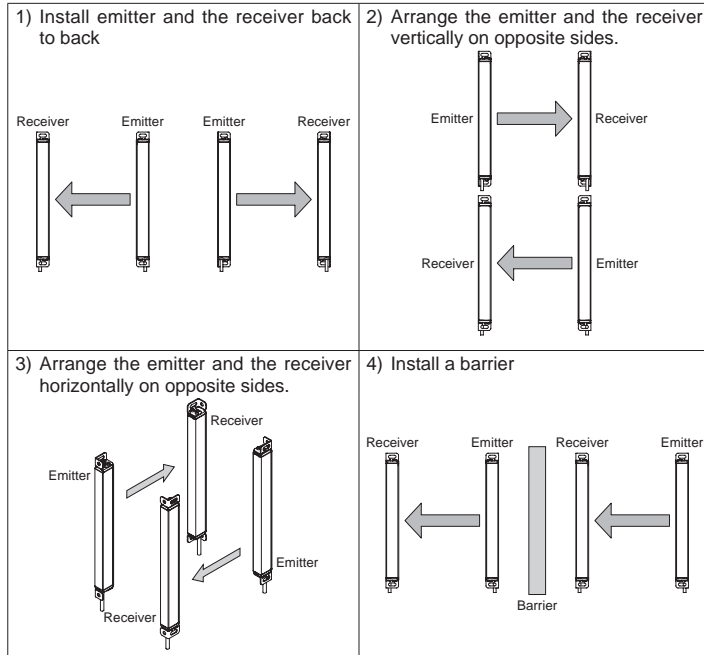

<Reference>

The above figures are just examples of device placement. If there are any questions or problems, please contact our office.

⚠ WARNING

Position the emitter and receiver so that their cables are aligned. Failure to do so will cause the system to malfunction.

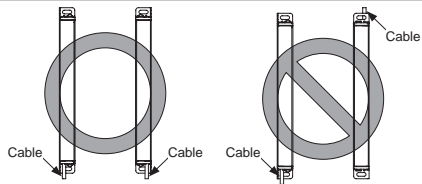

5 MOUNTING

⚠ CAUTION

The minimum bending radius of the cable is R5mm. Mount the device considering the cable bending radius.

<Reference>

Mount the emitter and the receiver at the same level and parallel to each other. The effective aperture angle of this device is $\pm 2.5^\circ$ or less for a sensing distance of 3m or more.

<In case of using standard mounting bracket MS-SF4BC-1 (optional)>

- Secure the bracket with two M3 screws (length: 5mm). The tightening torque should be $0.5N \cdot m$.

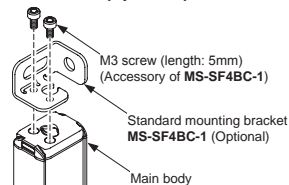

- Mount the standard mounting bracket on the mounting surface using hexagon-socket head bolts [M5 (purchase separately)].

<In case of rear mounting>

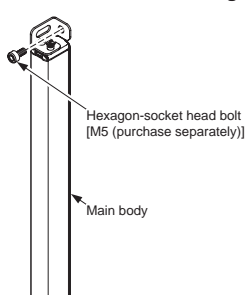

<In case of side mounting>

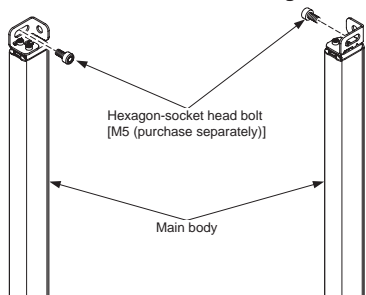

<In case of using intermediate supporting bracket MS-SF4BC-5 (optional)>

- Secure the bracket with two M3 flat head screws (purchase separately). The tightening torque should be $0.5N \cdot m$.

<In case of rear mounting>

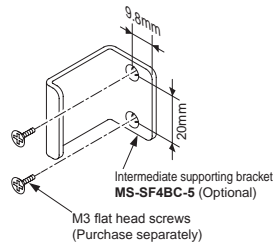

<In case of side mounting>

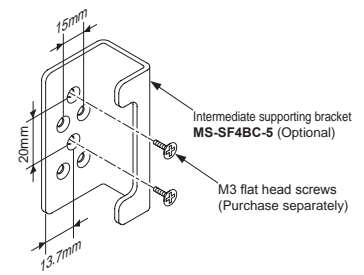

- Insert this device into the intermediate supporting bracket.

<In case of rear mounting>

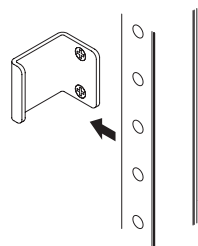

<In case of side mounting>

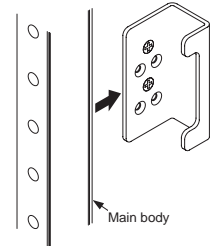

Note: SF4B-H-C: 48 beam channels or more, SF4B-A-C: 24 beam channels or more require intermediate supporting bracket MS-SF4BC-5 (optional).

Refer "our web site (<http://panasonic.net/id/pidsx/global>)" for mounting position.

40 to 56 beam channels for SF4B-H-C, 20 to 28 beam channels for SF4B-A-C: 1 set
64 to 96 beam channels for SF4B-H-C, 32 to 48 beam channels for SF4B-A-C: 2 sets

6 WIRING

⚠ WARNING

- Earth the machine or the support where the device is mounted on to frame ground (F.G.). Failure to do so could cause the malfunction of the device by noise, resulting in death or serious injury. Furthermore, the wiring should be done in a metal box connected to the frame ground (F.G.).
- Take countermeasure against the system to be applied for this device so as not to carry out the dangerous performance caused by the earth failure. Failure to do so could cause invalid for the system stop, resulting in death or serious injury.
- When the synchronization + wire (orange) and synchronization - wire (orange / black) is extended with a cable other than exclusive cable, use a $0.2mm^2$ or more shielded twisted pair cable.
- In case of using the interlock function, be sure there exists no operator inside of the dangerous area. It causes death or serious injury without the confirmation.
- The reset switch shall be placed in area where all over the dangerous zone shall be comprehend and out side of the dangerous zone.
- Do not use the emission halt function and auxiliary output for the purpose of stopping the machine in which this device is installed. Failure to do so could result in death or serious injury.
- Make sure manually to operate system for starting override function. Furthermore, the system shall be placed in area where all over the dangerous zone shall be comprehend and outside of the dangerous zone.
- Using override function, make sure that there exist no operator in the dangerous zone, which may result in death or serious injury.

⚠ CAUTION

Make sure to insulate the ends of the unused lead wires.

<Reference>

Use a safety relay unit or an equivalent control circuit in safety for FSD.

• Power Supply Unit

⚠ CAUTION

Wire correctly using a power supply unit which conforms to the laws and standards of the region where this device is to be used. If the power supply unit is non-conforming or the wiring is improper, it can cause damage or malfunction of this device.

<Reference>

A specialist who has the required electrical knowledge should perform the wiring. The power supply unit must satisfy the conditions given below.

- Power supply unit authorized in the region where this device is to be used.
- Power supply unit SELV (safety extra low voltage) / PELV (protected extra low voltage) conforming to EMC Directive and Low-voltage Directive. (only for requiring CE marking conformation)
- Power supply unit conforming to the Low-voltage Directive and with an output of 100VA or less.
- The frame ground (F.G.) terminal must be connected to ground when using a commercially available switching regulator.
- Power supply unit with an output holding time of 20ms or more.
- In case a surge is generated, take countermeasures such as connecting a surge absorber to the origin of the surge.
- Power supply unit corresponding to CLASS 2 (only for requiring cTÜVus Mark

<In case of using I/O circuit for PNP output>

• I/O Circuit Diagrams

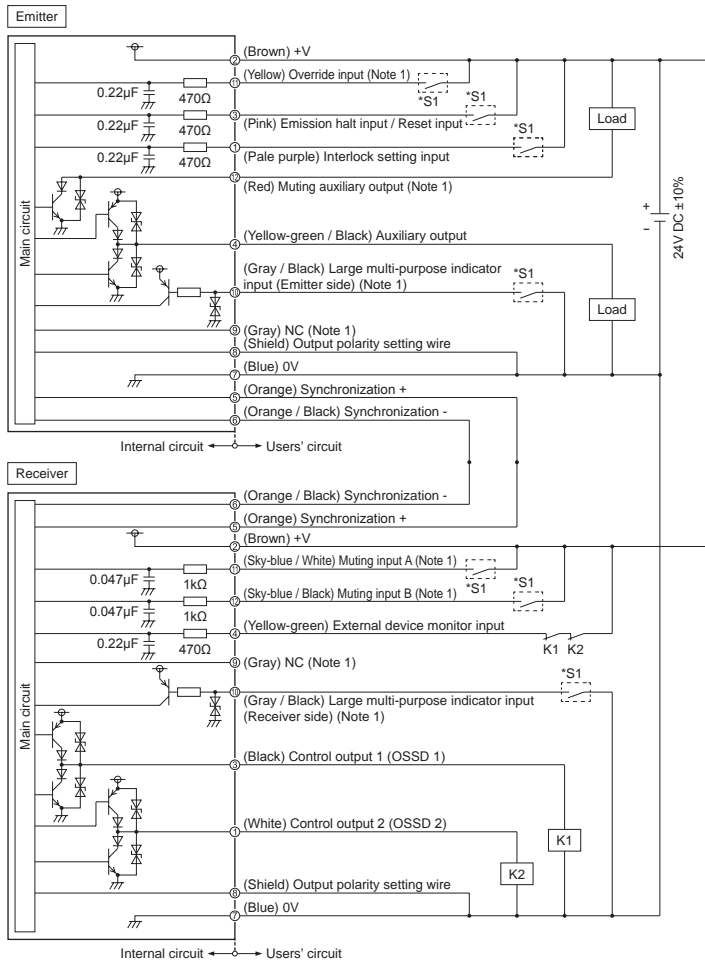

*S1
Switch S1
• Emission halt input / Reset input
For manual reset ... Vs to Vs - 2.5V (sink current 5mA or less) : Emission halt (Note 2), Open: Emission
For auto-reset ... Vs to Vs - 2.5V (sink current 5mA or less) : Emission (Note 2), Open: Emission halt
• Interlock setting input, Override input, Muting input A / B, External device monitor input
Vs to Vs - 2.5V (sink current 5mA or less) : Valid (Note 2), Open: Invalid
• Large multi-purpose indicator input
0 to + 1.5V (source current: 5mA or less): Lights up, Open: Turn OFF

Notes: 1) The circuit diagram shown above is for SF4B-CA-J05. For SF4B-C, yellow, red, gray, gray / black, sky-blue / white, sky-blue / black, there is no lead wire.
2) Vs is the applying supply voltage.

<Reference>
K1, K2: External device (Forced guided relay or magnetic contactor)

• Basic Wiring

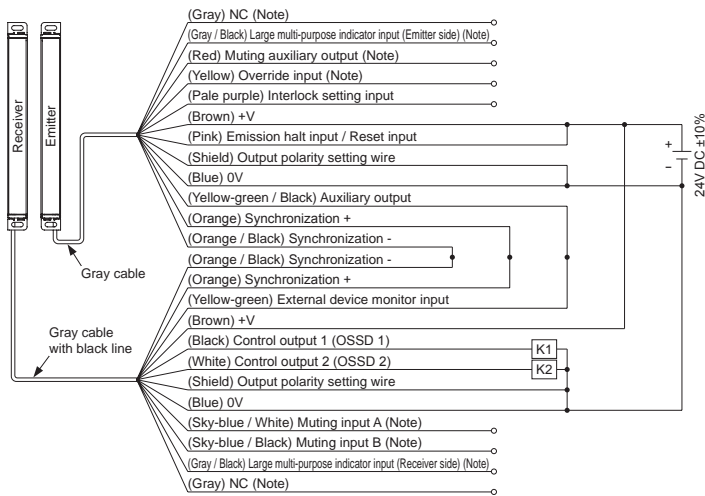

Interlock function	Invalid (Auto-reset)
External device monitor function	Invalid
Auxiliary output	Cannot be used

Note: The circuit diagram shown above is for SF4B-CA-J05. For SF4B-C, yellow, red, gray, gray / black, sky-blue / white, sky-blue / black, there is no lead wire.

<In case of using I/O circuit for NPN output>

• I/O Circuit Diagrams

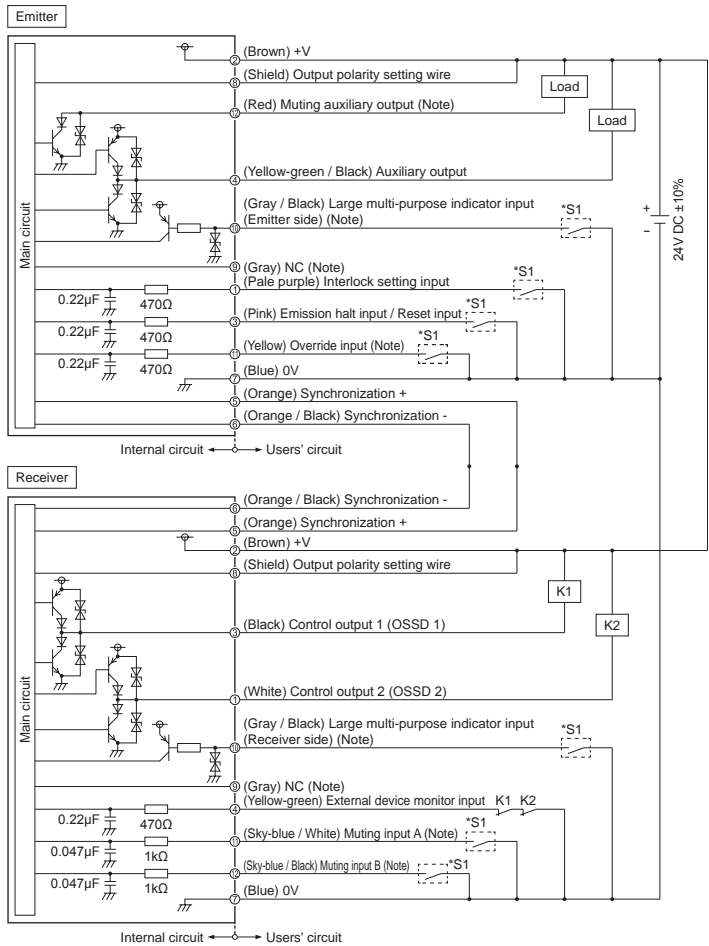

*S1
Switch S1
• Emission halt input / Reset input
For manual reset ... 0 to +1.5V (source current 5mA or less): Emission halt, Open: Emission
For auto-reset ... 0 to +1.5V (source current 5mA or less): Emission, Open: Emission halt
• Interlock setting input, Override input, Muting input A / B, External device monitor input
0 to + 1.5V (source current: 5mA or less): Valid, Open: Invalid
• Large multi-purpose indicator input
0 to + 1.5V (source current: 5mA or less): Lights up, Open: Turn OFF

Note: The circuit diagram shown above is for SF4B-CA-J05. For SF4B-C, yellow, red, gray, gray / black, sky-blue / white, sky-blue / black, there is no lead wire.

<Reference>
K1, K2: External device (Forced guided relay or magnetic contactor)

• Basic Wiring

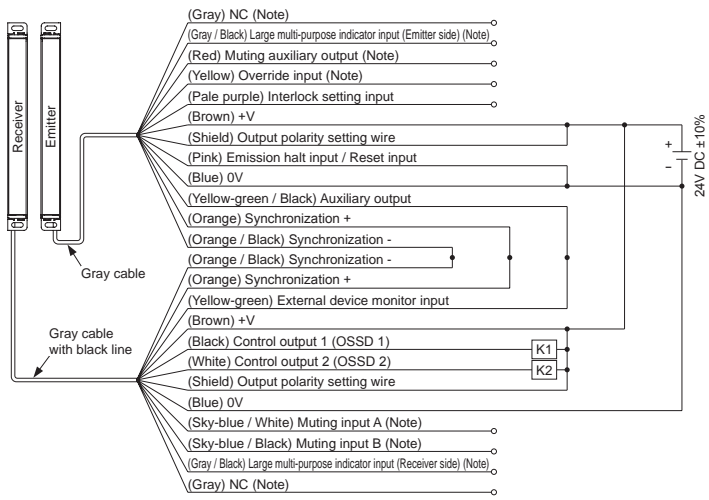

Interlock function	Invalid (Auto-reset)
External device monitor function	Invalid
Auxiliary output	Cannot be used

Note: The circuit diagram shown above is for SF4B-CA-J05. For SF4B-C, yellow, red, gray, gray / black, sky-blue / white, sky-blue / black, there is no lead wire.

7 OPERATION OF INDICATORS

• Normal Operation



◐ : Blinks in red, ◑ : Lights up in red, ◒ : Lights up in orange, ◓ : Lights up in green, ◔ : Turns OFF

Device status	Indicators (Note)		Control output	
	Emitter	Receiver	OSSD 1	OSSD 2
Light received status (all beams received)	RECEPTION ◑ OSSD ◑ STB ◑ FALUT ◑ PNP ◑ NPN ◑ CTRL ◑ HALT ◑	RECEPTION ◑ OSSD ◑ STB ◑ FALUT ◑ PNP ◑ NPN ◑ FUNCTION ◑ INTERLOCK ◑		ON
One or more lights blocked	RECEPTION ◐ OSSD ◐ STB ◐ FALUT ◐ PNP ◐ NPN ◐ CTRL ◐ HALT ◐	RECEPTION ◐ OSSD ◐ STB ◐ FALUT ◐ PNP ◐ NPN ◐ FUNCTION ◐ INTERLOCK ◐		OFF
Light blocked status Lights other than the top end blocked	RECEPTION ◑ OSSD ◑ STB ◑ FALUT ◑ PNP ◑ NPN ◑ CTRL ◑ HALT ◑	RECEPTION ◑ OSSD ◑ STB ◑ FALUT ◑ PNP ◑ NPN ◑ FUNCTION ◑ INTERLOCK ◑		OFF
Lights other than the bottom end blocked	RECEPTION ◑ OSSD ◑ STB ◑ FALUT ◑ PNP ◑ NPN ◑ CTRL ◑ HALT ◑	RECEPTION ◑ OSSD ◑ STB ◑ FALUT ◑ PNP ◑ NPN ◑ FUNCTION ◑ INTERLOCK ◑		OFF

Note: The status of the emitter / receiver indicators during operation above shows the case in PNP output setting mode. In case of NPN output setting mode, the NPN indicator (orange) lights up.

• When an error occurs



◕ : Blinks in yellow, ◑ : Lights up in red, ◒ : Lights up in orange, ◔ : Turns OFF

Device status	Indicators (Note)		Control output	
	Emitter	Receiver	OSSD 1	OSSD 2
Error state	RECEPTION ◑ OSSD ◑ STB ◑ FALUT ◑ PNP ◑ NPN ◑ CTRL ◑ HALT ◑	RECEPTION ◑ OSSD ◑ STB ◑ FALUT ◑ PNP ◑ NPN ◑ FUNCTION ◑ INTERLOCK ◑		OFF

Note: The status of the emitter / receiver indicators during operation above shows the case in PNP output setting mode. In case of NPN output setting mode, the NPN indicator (orange) lights up.

8 FUNCTION

- Refer "our web site (<http://panasonic.net/id/pidsx/global>)" for details of functions of this product.

9 MAINTENANCE

<Reference>

When any errors are found, refer to "our web site (<http://panasonic.net/id/pidsx/global>)" and report the symptoms to the maintenance in charge. If the rectification method is not clear, please contact our office. Please make a copy of this checklist, check each inspection item in the respective square, and file the list for record.

• Daily Inspection

⚠ WARNING

Be sure to inspect the following items prior to operation and confirm that there is no error. Operating this device without inspection or in an error condition can result in

Check column	Inspection item
<input type="checkbox"/>	Dangerous parts of the machine cannot be reached without passing through the sensing area of this device.
<input type="checkbox"/>	Some part of operator's body remains in the sensing area when operation is done with dangerous parts of the machine.
<input type="checkbox"/>	The calculated safety distance has been maintained or exceeded during installation.
<input type="checkbox"/>	There is no damage to the safety guard or protective structure.
<input type="checkbox"/>	There is no defect, fold, or damage in the wiring.
<input type="checkbox"/>	The corresponding connectors have been connected securely.
<input type="checkbox"/>	No dirt or scratches exist on the light emitting surface.
<input type="checkbox"/>	The test rod is not deformed or defective.
<input type="checkbox"/>	The operation indicator (green) of the emitter and the OSSD indicator (green) of the receiver light up when no object is present in the sensing area. The control output (OSSD 1 / 2) is in ON status. At this time, the effect of external noise can be inspected. In case external noise affects the operation, remove its cause and reinspect.
<input type="checkbox"/>	It should be possible to detect the test rod (ø25mm for SF4B-H-C□ or ø45mm for SF4B-A-C□) at three positions, directly in front of the emitter, midway between the emitter and the receiver, and directly in front of the receiver when the test rod is moved at a speed of 1,600mm/sec. The OSSD indicator (red) of the receiver and the operation indicator (red) of the emitter continue to light up as long as the test rod is present in the sensing area.
<input type="checkbox"/>	With the machine in the operating condition, the dangerous parts operate normally when no object is present in the sensing area.
<input type="checkbox"/>	With the machine in the operating condition, the dangerous parts stop immediately when the testrod is inserted into the sensing area at any of the three positions, directly in front of the emitter, midway between the emitter and the receiver, and directly in front of the receiver.
<input type="checkbox"/>	The dangerous parts remain stopped as long as the test rod is present in the sensing area.
<input type="checkbox"/>	The dangerous parts stop immediately when the power supply of this device is turned OFF.
<input type="checkbox"/>	The control output (OSSD 1 / 2) must turn OFF when the emission halt input wire (pink) is open (for manual reset: connected to 0V, +V). At this time, the effect of external noise can be inspected. In case external noise affects the operation, remove its cause and reinspect.
<input type="checkbox"/>	Be sure to check the operation of the muting function before its use. Furthermore, check the state of the muting indicator (cleanliness or brightness, etc.)

• Periodic Inspection (Every Six Months)

⚠ WARNING

Be sure to inspect the following items every six months and confirm that there is no error. Operating this device without inspection or in an error condition can result in death or serious injury.

Check column	Inspection item
<input type="checkbox"/>	The structure of the machine does not obstruct any safety mechanism for stopping operation.
<input type="checkbox"/>	No modification has been made in the machine controls which obstructs the safety mechanisms.
<input type="checkbox"/>	The output of this device is correctly detected.
<input type="checkbox"/>	The wiring from this device is correct.
<input type="checkbox"/>	The overall response time of the complete machine is equal or less than the calculated value.
<input type="checkbox"/>	The actual number of operation cycle (time) of the limited lifetime parts (relay, etc.) is less than their rated operation cycles (time).
<input type="checkbox"/>	No screws or connectors of this device are loose.
<input type="checkbox"/>	No extraneous light source or reflective object has been added near this device.

• Inspection after Maintenance

- When any parts of this device are replaced.
- When some abnormality is felt during operation.
- When beam-axis alignment of the emitter and receiver is done.
- When the device installation place or environment is changed.
- When the wiring method or wiring layout is changed.
- When FSD (Final Switching Device) parts are replaced.
- When FSD (Final Switching Device) setting is changed.

10 SPECIFICATIONS

Type	20mm pitch type	40mm pitch type
Model No.	SF4B-H-C□	SF4B-A-C□
Number of beam channels	12 / 16 / 20 / 24 / 28 / 32 / 36 / 40 / 48 / 56 / 64 / 72 / 80 / 88 / 96	8 / 12 / 16 / 20 / 24 / 28 / 32 / 36 / 40 / 44 / 48
Protective height	263.4 (12 channels) to 1,943.4 (96 channels) mm	343.4 (8 channels) to 1,943.4 (48 channels) mm
Sensing range	0.3 to 7m	
Minimum sensing object	ø25mm opaque object	ø45mm opaque object
Supply voltage	24V DC ±10%	
Control output (OSSD 1 / 2)	Maximum source (PNP) / sink (NPN) current: 200mA, Residual voltage: 2.5V or less Leakage current: 0.1mA or less, Maximum load capacity: 0.22µF, Load wiring resistance: 3Ω or less	
Response time	When OFF: 14ms or less, When ON: 80 to 90ms	
Auxiliary output setting (AUX)	Maximum source (PNP) / sink (NPN) current: 60mA, Residual voltage: 2.5V or less	
Muting auxiliary output	Maximum sink current: 100mA, Residual voltage: 2.5V or less	
Ambient temperature	-10 to +55°C, Storage: -25 to +60°C	
Ambient humidity	30 to 85%RH, Storage: 30 to 85%RH	

11 CE MARKING DECLARATION OF CONFORMITY

Itemized Essentials of EU Declaration of Conformity

Manufacturer's Name: Panasonic Industrial Devices SUNX Co., Ltd.
Manufacturer's Address: 2431-1, Ushiyama-cho, Kasugai, Aichi 486-0901, Japan
EU Representative's Name: Panasonic Marketing Europe GmbH Panasonic Testing Center
EU Representative's Address: Winsbergring 15, 22525 Hamburg, Germany

Product: Active Opto-electronic Protective Device (Light Curtain)

Model Name: SF4B Series

Trade Name: Panasonic

Application of Council Directive:

- 2006/42/EC Machinery Directive
- 2004/108/EC EMC Directive (Valid until April 19, 2016)
- 2014/30/EU EMC Directive (Valid from April 20, 2016)
- 2011/65/EU RoHS Directive

Harmonized standards:

- EN 61496-1: 2013
- EN ISO 13849-1: 2008
- EN 55011: 2009+A1: 2010
- EN 61000-6-2: 2005
- EN 50581: 2012

Type Examination: Certified by TÜV SÜD Product Service GmbH Ridlerstrasse
65 80339 München Germany

Panasonic Industrial Devices SUNX Co., Ltd.

Compact Light Curtain / Type 4

SF4B-□C□

Instruction Manual

WUME-SF4BC-7



(MEMO)

Thank you for purchasing Panasonic Industrial Devices SUNX's Compact Light Curtain, **SF4B-C**. Please read this instruction manual carefully and thoroughly for the correct and optimum use of this device.

Kindly keep this manual in a convenient place for quick reference.

This device is a light curtain for protecting a person from dangerous parts of a machine which can cause injury or accident.

This manual is for the following personnel:

- who have undergone suitable training,
- who have knowledge of the light curtains as well as the safety systems and the standards,
- who are responsible for the introduction of this device,
- who design the system using this device,
- who install and connect this device,
- who manage and operate a plant using this device.

Notes

- 1) All the contents of this instruction manual are the copyright of the publishers, and may not be reproduced (even extracts) in any form by any electronic or mechanical means (including photocopying, recording, or information storage and retrieval) without permission in writing from the publisher.
- 2) The contents of this instruction manual may be changed without prior notice for further improvement of the device.
- 3) Though we have carefully drawn up the contents of this instruction manual, if there are any aspects that are not clear, or any error that you may notice, please contact our local Panasonic Industrial Devices SUNX office of the nearest distributor.
- 4) English and Japanese are original instructions.

Contents

Chapter 1 Introduction	6
1-1 Attention Marks	6
1-2 Safety Precautions	6
1-3 Applicable Standards / Regulations	9
1-4 Confirmation of Packed Contents	10
Chapter 2 Before Using This Device	11
2-1 Features	11
2-2 Part Description	11
2-3 Protection Area	14
2-3-1 Sensing Area	14
2-3-2 Safety Distance	15
2-3-3 Influence of Reflective Surfaces	19
2-3-4 Device Placement	20
2-4 Mounting	22
2-4-1 Mounting of the Mounting Bracket	22
2-5 Wiring	36
2-5-1 Power Supply Unit	36
2-5-2 I/O Circuit Diagrams and Output Waveform	37
2-5-3 Wiring · Connecting Procedure and Connector Pin Arrangement	43
2-5-4 Basic Wiring	45
2-5-5 Wiring for Manual Reset (Interlock is Valid)	49
2-5-6 Wiring for Auto-reset (Interlock is Invalid)	53
2-5-7 Wiring Configuration for Invalid External Device Monitor Function	57
2-5-8 Wiring Configuration for Valid Muting Function (For SF4B-□CA-J05 only)	61
2-6 Adjustment	63
2-6-1 Beam-axis Alignment	63
2-6-2 Operation Test	65
2-6-3 Operation	66
Chapter 3 Functions	71
3-1 Self-diagnosis Function	71
3-2 Interlock Function	71
3-3 Emission Halt Function	72
3-4 Auxiliary Output (Non-safety Output)	73
3-5 External Device Monitor Function	73
3-6 Muting Function (For SF4B-□CA-J05 only)	75
3-7 Override Function (For SF4B-□CA-J05 only)	78
3-8 Functions Using Handy Controller (SFB-HC) (Optional)	80
Chapter 4 Maintenance	83
4-1 Daily Inspection	83
4-2 Periodic Inspection (Every Six Months)	84
4-3 Inspection after Maintenance	84

Chapter 5 Troubleshooting	85
5-1 Troubleshooting of Emitter	85
5-2 Troubleshooting of Receiver.....	87
Chapter 6 Specifications / Dimensions	89
6-1 Specifications.....	89
6-2 Options.....	96
6-3 Dimensions.....	99
6-3-1 Rear Mounting with MS-SF4BC-1 and MS-SF4BC-5	99
6-3-2 Side Mounting with MS-SF4BC-1 and MS-SF4BC-5	100
6-3-3 Rear Mounting with MS-SF4BC-2 and MS-SF4BC-4	101
6-3-4 In Case Mounting in Confined Space with MS-SF4BC-2 and MS-SF4BC-4	102
6-3-5 Side Mounting with MS-SF4BC-3 and MS-SF4BC-4	103
6-3-6 In Case Mounting in Confined Space with MS-SF4BC-3 and MS-SF4BC-4	104
6-3-7 Mounting with MS-SF4BC-6 and MS-SF4BC-7	105
6-3-8 In Case Mounting in Confined Space with MS-SF4BC-6 and MS-SF4BC-7	106
6-3-9 Mounting with MS-SF4BCH-□ and MS-SF4BC-1	107
6-3-10 Mounting Brackets.....	108
Chapter 7 Others.....	119
7-1 Glossary	119
7-2 CE Marking Declaration of Conformity.....	121

Chapter 1 Introduction

1-1 Attention Marks

This instruction manual employs the following attentions marks “**⚠ WARNING**,” “**⚠ CAUTION**” depending on the degree of the danger to call operator's attention to each particular action. Read the following explanation of these marks thoroughly and observe these notices without fail.

⚠ WARNING If you ignore the advice with this mark, death or serious injury could result.

⚠ CAUTION If you ignore the advice with this mark, injury or material damage could result.

<Reference> It gives useful information for better use of this device.

1-2 Safety Precautions

- Use this device as per its specifications. Do not modify this device since its functions and capabilities may not be maintained and it may malfunction.
- This device has been developed / produced for industrial use only.
- This device is suitable for indoor use only.
- Use of this device under the following conditions or environments is not presupposed. Please consult us if there is no other choice but to use this device in such an environment.
 - 1) Operating this device under conditions or environments not described in this manual.
 - 2) Using this device in the following fields: nuclear power control, railroad, aircraft, auto mobiles, combustion facilities, medical systems, aerospace development, etc.
- When this device is to be used for enforcing protection of a person from any danger occurring around an operating machine, the user should satisfy the regulations established by national or regional security committees (Occupational Safety and Health Administration: OSHA, the European Standardization Committee, etc.). Contact the relative organization(s) for details.
- In case of installing this device to a particular machine, follow the safety regulations in regard to appropriate usage, mounting (installation), operation and maintenance. The users including the installation operator are responsible for the introduction of this device.
- Note that this device may be damaged if it is subject to a strong shock (if it is dropped onto the floor, for example).
- Use this device by installing suitable protection equipment as a countermeasure for failure, damage, or malfunction of this device.
- Before using this device, check whether the device performs properly with the functions and capabilities as per the design specifications.
- In case of disposal, dispose this device as an industrial waste.

⚠ WARNING

◆ Machine designer, installer, employer and operator

- The machine designer, installer, employer and operator are solely responsible to ensure that all applicable legal requirements relating to the installation and the use in any application are satisfied and all instructions for installation and maintenance contained in the instruction manual are followed.
- Whether this device functions as intended to and systems including this device comply with safety regulations depends on the appropriateness of the application, installation, maintenance and operation. The machine designer, installer, employer and operator are solely responsible for these items.

◆ Engineer

- The engineer would be a person who is appropriately educated, has widespread knowledge and experience, and can solve various problems which may arise during work, such as a machine designer, or a person in charge of installation or operation etc.

◆ Operator

- The operator should read this instruction manual thoroughly, understand its contents, and perform operations following the procedures described in this manual for the correct operation of this device.
- In case this device does not perform properly, the operator should report this to the person in charge and stop the machine operation immediately. The machine must not be operated until correct performance of this device has been confirmed.

◆ Environment

- Do not use a mobile phone or a radio phone near this device.
- If there exists a reflective surface in the place where this device is to be installed, make sure to install this device so that reflected light from the reflective surface does not enter into the receiver, or take countermeasures such as painting, masking, roughening, or changing the material of the reflective surface, etc. Failure to do so may cause the device not to detect, resulting in death or serious injury.
- Do not install this device in the following environments.
 - 1) Areas exposed to intense interference (extraneous) light such as high-frequency fluorescent lamp (inverter type), rapid starter fluorescent lamp, stroboscopic lights or direct sunlight.
 - 2) Areas with high humidity where condensation is likely to occur
 - 3) Areas exposed to corrosive or explosive gases
 - 4) Areas exposed to vibration or shock of levels higher than that specified
 - 5) Areas exposed to contact with water
 - 6) Areas exposed to too much steam or dust

◆ Installation

- Always keep the correctly calculated safety distance between this device and the dangerous parts of the machine.
- Install extra protection structure around the machine so that the operator must pass through the sensing area of this device to reach the dangerous parts of the machine.
- Install this device such that some part of the operator's body always remains in the sensing area when operator is done with the dangerous parts of the machine.
- Do not install this device at a location where it can be affected by wall reflection.
- When installing multiple sets of this device, connect the sets and, if necessary, install some barriers such that mutual interference does not occur. For details, refer to "2-3-4 Device Placement."
- Do not use this device in a reflective configuration.
- The corresponding emitter and receiver must have the same serial No. and be correctly oriented.

WARNING

◆ **Machine in which this device is installed**

- When this device is used in the “PSDI Mode,” an appropriate control circuit must be configured between this device and the machinery. For details, be sure to refer to the standards or regulations applicable in each region or country.
- In Japan and China, Korea, do not use this device as safety equipment for a press machine.
- Do not install this device with a machine whose operation cannot be stopped immediately in the middle of an operation cycle by an emergency stop equipment.
- This device starts the performance after 2 seconds from the power ON. Have the control system started to function with this timing.

◆ **Wiring**

- Be sure to carry out the wiring in the power supply OFF condition.
- All electrical wiring should conform to the regional electrical regulations and laws. The wiring should be done by engineer(s) having the special electrical knowledge.
- Do not run the wires together with high-voltage lines or power lines or put them in the same raceway. This can cause malfunction due to induction.
- In case of extending the cable of the emitter or the receiver, each can be extended up to 50m by using the exclusive cable. Extending the cable longer than 50m may cause malfunction, which can result in death or serious injury.
- Do not control the device only at one control output (OSSD 1 / 2).
- In order that the output is not turned to ON due to earth fault of the control output (OSSD 1 / 2) wires, be sure to ground to 0V side (PNP output) / +V side (NPN output).
- When using this device in Korea with S-mark, be sure to ground to 0V side (PNP output).

◆ **Maintenance**

- When replacement parts are required, always use only genuine supplied replacement parts. If substitute parts from another manufacturer are used, the device may not come to detect, result in death or serious injury.
- The periodical inspection of this device must be performed by an engineer having the special knowledge.
- After maintenance or adjustment, and before starting operation, test this device following the procedure specified in “**Chapter 4 Maintenance.**”
- Clean this device with a clean cloth. Do not use any volatile chemicals.

◆ **Others**

- Never modify this device. Modification may cause the device not to detect, resulting in death or serious injury.
- Do not use this device to detect objects flying over the sensing area.
- Do not use this device to detect transparent objects, translucent objects or objects smaller than the specified minimum sensing objects.

1-3 Applicable Standards / Regulations

This device complies with the following standards regulations.

<EU Directives>

EU Machinery Directive 2006/42/EC
EMC Directive 2004/108/EC (Valid until April 19, 2016)
EMC Directive 2014/30/EU (Valid from April 20, 2016)
RoHS Directive 2011/65/EU

<European Standards>

EN 61496-1 (Type 4), EN 55011, EN 61000-6-2, EN 50178
EN ISO 13849-1: 2008 (Category 4, PLe)

<International Standards>

IEC 61496-1/2 (Type 4), ISO 13849-1: 2006 (Category 4, PLe), IEC 61508-1 to 7 (SIL3)

<Japanese Industrial Standards (JIS)>

JIS B 9704-1/2 (Type 4), JIS B 9705-1 (Category 4), JIS C 0508 (SIL3)

<Standards in US / Canada>

ANSI/UL 61496-1/2 (Type 4), ANSI/UL 508
CAN/CSA C22.2 No.14, CAN/CSA E61496-1/2 (Type 4)

<Regulations in US>

OSHA 1910.212, OSHA 1910.217(C), ANSI B11.1 to B11.19, ANSI/RIA 15.06

Regarding EU Machinery Directive, a Notified Body, TÜV SÜD, has certified with the type examination certificate.

With regard to the standards in US/Canada, a NRTL, TÜV SÜD has certified for cTÜVus Mark.

<Regulations in Korea>

S1-G-35-2005, S2-W-11-2003

The S-mark certificate has been certified by Korea Occupational Safety & Health Agency (KOSHA).

<Reference>

The conformity to JIS, OSHA and ANSI for this device has been evaluated by ourselves.
The cTÜVus mark "Ⓢ" indicates that this device conforms to NRTL certification (such as UL) in the US and CSA certification in Canada.
This device conforms to the EMC Directive and the Machinery Directive. The CE mark on the main body indicates that this device conforms to the EMC Directive.
Ⓢ mark marked on this device shows that this device has certified with the type examination certificate.

WARNING

- In Japan, never use this device as a safety equipment for any press machine or shearing machine.
- When this device is used in a place other than the places shown above, be sure to confirm the standards or regulations applicable in each region or country before use.

Introduction

Before the use of this device, construct the control system that satisfies the following requirements to secure the safety of the whole system.

To use for Category 4 or 3

- **To prevent the loss of the safety function due to a single fault.**
Always use two types of control output (OSSD 1 / 2).
- **To prevent the loss of the safety function due to the accumulation of the faults.**
Construct the control system that can stop a device if discrepancy between control outputs (OSSD 1 / 2) is detected.
<The example of the way to detect the discrepancy of control outputs>
(Example 1) Use the relay unit or the controller for the light curtain.
(Example 2) Monitor of the control outputs (OSSD 1 / 2) with the safety PLC.
(Example 3) Monitor of the contact point welding in case the safety relay is used.

To use for Category 2

If one type of control output (OSSD) is used, the auxiliary output connects to PLC to monitor the operation of this device, and construct the control system that can stop a device if discrepancy between the control output (OSSD) and the auxiliary output is detected. It is possible to use another type of control output (OSSD) .

1-4 Confirmation of Packed Contents

- Sensor: Emitter, Receiver 1 pc. each
- Test Rod 1 pc.
- **SF4B-H□C, SF4B-H□CA-J05: SF4B-TR25** (ø25 x 220mm)
- Quick Instruction Manual (Japanese, English, Chinese, Korean) 1 pc. each language

2-1 Features

This device is the light curtain with the following features.

- No special controller is required.
- The control output (OSSD 1 / 2) is PNP / NPN output switching type.
- Beam-axis alignment indicators which make beam-axis alignment easy are incorporated.
- Each function setting is available by using the handy controller (SFB-HC) (optional). Refer to “3-8 Functions Using Handy Controller (SFB-HC) (Optional)” for details.
- Refer to “6-2 Options” for details of options.

2-2 Part Description

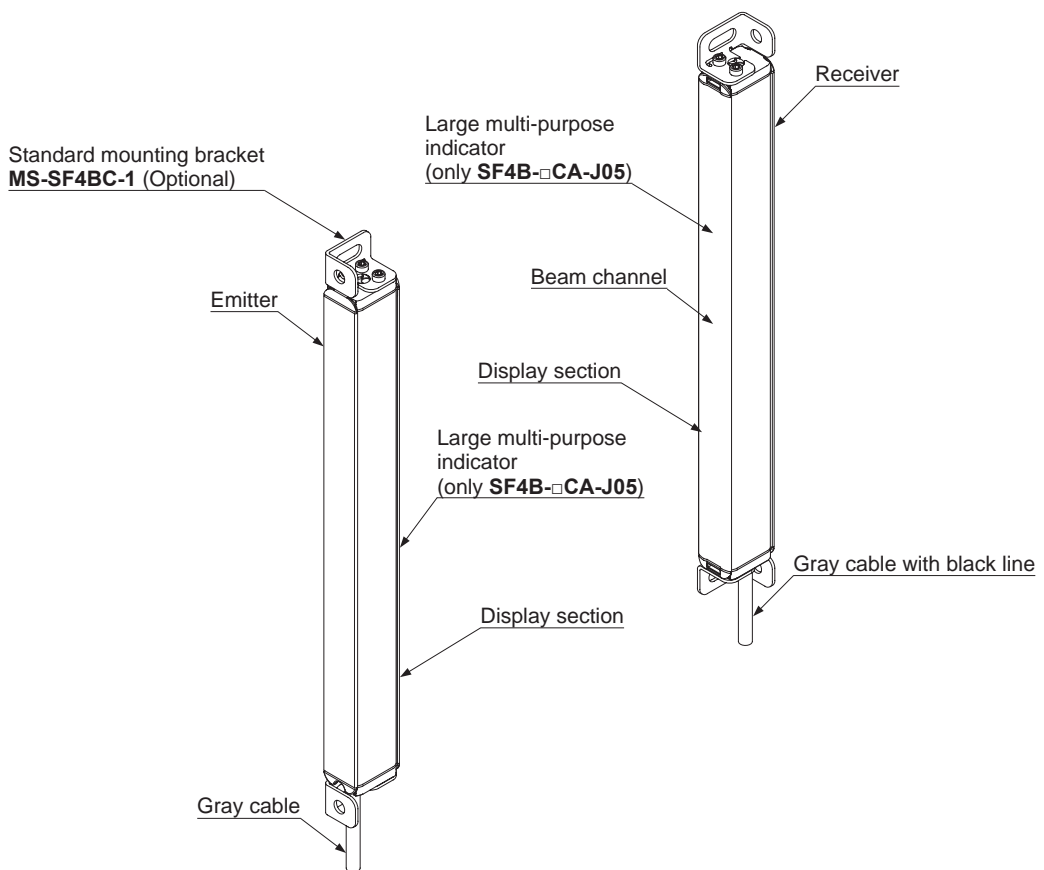

Part Description

<Emitter>

It emits light to the receiver facing it. Furthermore, the status of the emitter and the receiver is indicated on its display section.

<Receiver>

It receives light from the emitter facing it. Simultaneously, it turns ON the control output (OSSD 1 / 2) when the all beam channels receive light from emitter, and it turns OFF the control output (OSSD 1 / 2) when one or more beam channels are blocked light. [Exclude when using the muting function (Note 1) or the blanking function (Note 2).]

Besides, the receiver displays its status on the display section.

Notes: 1) The muting function is only available for the **SF4B-□CA-J05**.

In case of using the muting function, the following items, 12-core bottom cap cable (**SFB-CB05-MU**, **SFB-CCB□-MU**) (optional) and muting sensor are required. Please purchase 12-core bottom cap cable and muting sensor separately.

2) The blanking function is set by using the handy controller (**SFB-HC**) (optional). Please purchase the handy controller separately.

<Beam channel>

The light emitting elements of the emitter and the light receiving elements of the receiver are placed at the following intervals, 20mm (**SF4B-H□C□**), and 40mm (**SF4B-A□C□**).

<Standard mounting bracket MS-SFC-1 (optional)>

This bracket is used to mount an emitter and receiver on its back or side surface. This can be mounted with a single hexagon-socket head bolt [M5].

<Display section>

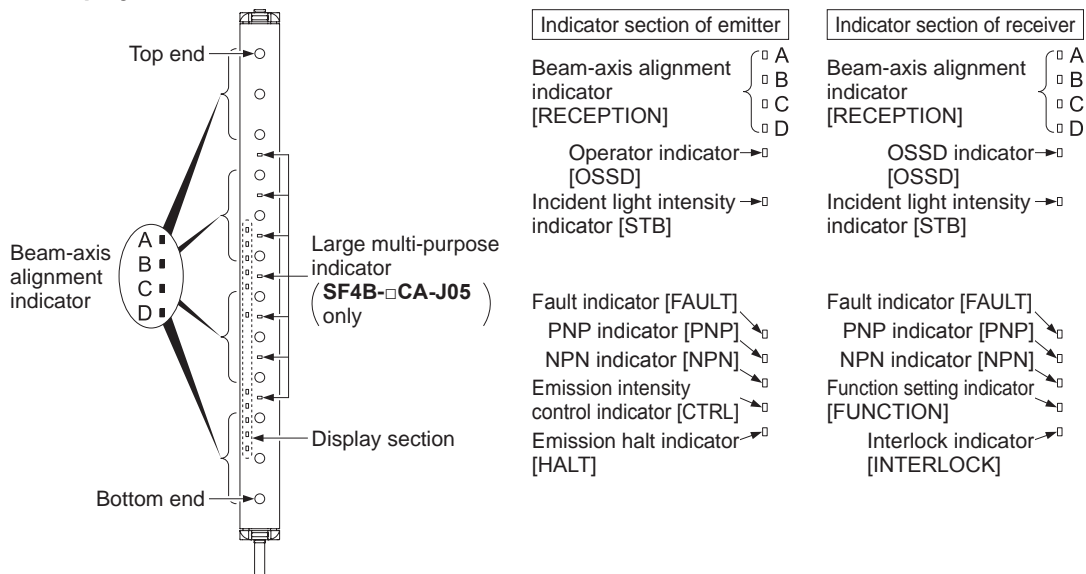

• Common to emitter and receiver

Description	Function
Large multi-purpose indicator (Orange) (Mounted on SF4B-□CA-J05 only)	When input for the large multi-purpose indicator is validated: lights up When input for the large multi-purpose indicator is invalidated: OFF
Beam-axis alignment indicator (Red / Green)	A When device top receives light: lights up in red When device top end receives light: blinks in red When control output (OSSD 1 / 2) is ON: lights up in green
	B When device upper middle receives light: lights up in red When control output (OSSD 1 / 2) is ON: lights up in green
	C When device lower middle receives light: lights up in red When control output (OSSD 1 / 2) is ON: lights up in green
	D When device bottom receives light: lights up in red When device bottom end receives light: blinks in red When control output (OSSD 1 / 2) is ON: lights up in green
Incident light intensity indicator (Orange / Green) [STB]	When stable light is received: lights up in green When unstable light is received: lights up in orange When light is blocked (Note 1): OFF (Note 3)
Fault indicator (Yellow) [FAULT]	When fault occurs in the device: lights up or blinks
PNP indicator (Orange) [PNP]	When PNP output is set: lights up
NPN indicator (Orange) [NPN]	When NPN output is set: lights up

• Emitter

Description	Function
Operator indicator (Red / Green) [OSSD] (Note 2)	Both end beam channels are received: blinks in red All beam channels are received: lights up in green When control output (OSSD 1 / 2) is OFF: lights up in red When control output (OSSD 1 / 2) is ON: lights up in green
Emission intensity control indicator (Orange) [CTRL]	When emission intensity is controlled: lights up
Emission halt indicator (Orange) [HALT]	When light emission is halt: lights up When light is emitted: OFF

• Receiver

Description	Function
OSSD indicator (Red / Green) [OSSD]	Both end beam channels are received: blinks in red All beam channels are received: lights up in green When control output (OSSD 1 / 2) is OFF: lights up in red When control output (OSSD 1 / 2) is ON: lights up in green
Function setting indicator (Orange) [FUNCTION]	When connecting the handy controller: blinks When blanking function is used: lights up (Note 3)
Interlock indicator (Yellow) [INTERLOCK]	When device is interlocked: lights up Other cases: OFF

- Notes: 1) "When light is blocked" refers to the status that there exists any object blocking light in the sensing area.
2) Since the color of the operation indicator changes according to ON / OFF status of the control output (OSSD 1 / 2), the operation indicator is marked as "OSSD" on the device.
3) The blanking function is set by using the handy controller (**SFB-HC**) (optional). Please purchase the handy controller separately.
4) The description given in [] is marked on the device.

Protection Area

2-3 Protection Area

2-3-1 Sensing Area

⚠ WARNING

- Be sure to install protection structure around the machine so that the operator must pass through the sensing area of this device to reach the dangerous parts of the machine. Furthermore, ensure that some part of the operator's body always remains in the sensing area when operation is done with the dangerous parts of the machine. Failure to do so can result in death or serious injury.
- Do not use any reflection type or recursive reflection type arrangement.
- Furthermore, facing several receivers towards one emitter, or vice versa, could produce a non-sensing area or cause mutual interference, which may result in death or serious injury.

The sensing area is the zone formed by the sensing height of the device and the sensing range between the emitter and the receiver.

The sensing height is determined by the number of beam channels. Furthermore, the sensing range can be 0.3 to 7m. Take care that if the sensing range is under 0.3m, malfunction may occur due to the optical structure.

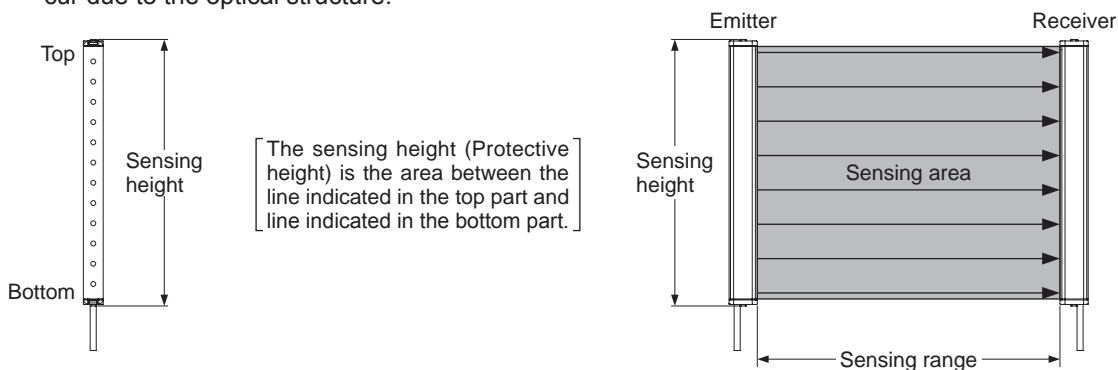

<Example of Correct Installation>

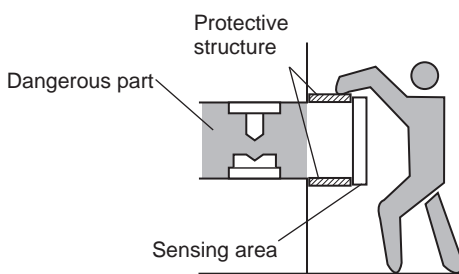
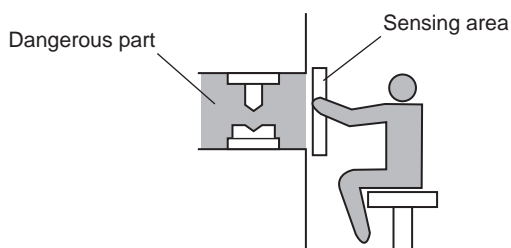

<Example of Incorrect Installation>

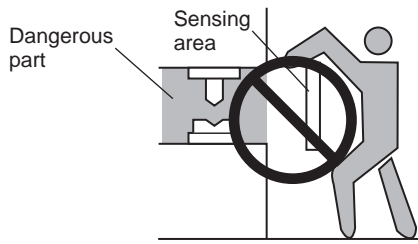
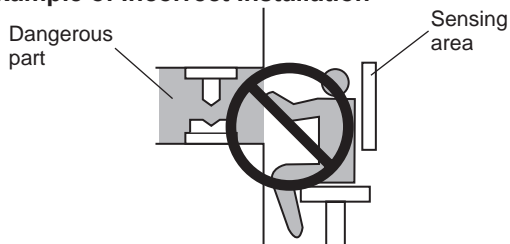

2-3-2 Safety Distance

⚠ WARNING

- Calculate the safety distance correctly, and always maintain the distance which is equal to or greater than the safety distance, between the sensing area of this device and the dangerous parts of the machine. If the safety distance is miscalculated or if sufficient distance is not maintained, the machine will not stop quickly before reaching to the dangerous parts, which can result in death or serious injury.
- Before designing the system, refer to the relevant standards of the region where this device is to be used, and then install this device.
Furthermore, the equation described in the next pages is to be used only in case the intrusion direction is perpendicular to the sensing area. In case the intrusion direction is not perpendicular to the sensing area, be sure to refer to the relevant standard (regional standard, specification of the machine, etc.) for details of the calculation.
- The max. response time of the machine is from the point that the machine receives the halt signal from this device to the point that the dangerous parts of the machine stops. The max. response time of the machine should be timed with the machine to be actually used.
- The size of the minimum sensing object for this device varies depending on the case whether the floating blanking function is applied or not. Calculate the safety distance with the proper size of the minimum sensing object and appropriate equation.

<Size of minimum sensing object when applying floating blanking function>

	Floating blanking function			
	Invalid	Setting (Note)		
		1 beam channel	2 beam channel	3 beam channel
SF4B-H□C□ (20mm-beam channel pitch type)	ø25mm	ø45mm	ø65mm	ø85mm
SF4B-A□C□ (40mm-beam channel pitch type)	ø45mm	ø85mm	ø125mm	ø165mm

Note: Refer to “3-8 Functions Using Handy Controller (SFB-HC) (Optional)” for details of the floating blanking function.

The safety distance is the minimum distance that must be maintained between the device and the dangerous parts of the machine so that the machine can be stopped before a human body or an object can reach the dangerous parts.

The safety distance is calculated based on the equation described in the next page when a person moves perpendicular (normal intrusion) to the sensing area of the device.

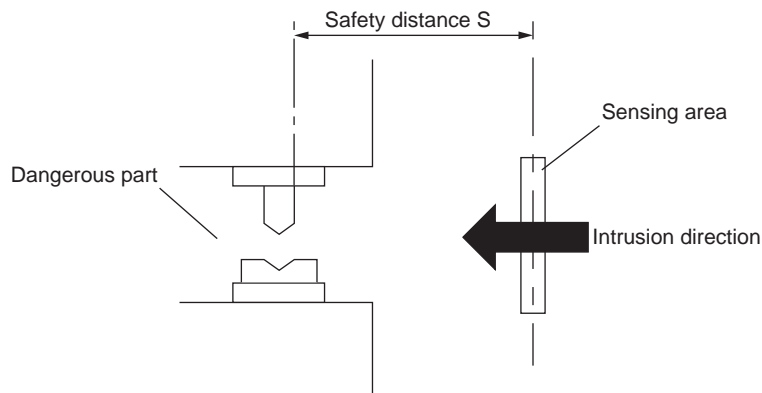

Protection Area

[For use in Europe (EU) (as EN 999)] (Also applicable to ISO 13855 / JIS B 9715)
(For intrusion direction perpendicular to the sensing area)

<In case that the minimum sensing object is $\varnothing 40\text{mm}$ or less>

- Equation 1 $S = K \times T + C$
 - S : Safety distance (mm)
Minimum required distance between the sensing area surface and the dangerous parts of the machine
 - K : Intrusion velocity of operator's body or object (mm/sec.)
Taken as 2,000 (mm/sec.) for calculation
 - T : Response time of total equipment (sec.)
 $T = T_m + T_{SF4B}$
T_m : Maximum halting time of machine (sec.)
T_{SF4B} : Response time of this device (sec.)
 - C : Additional distance calculated from the size of the minimum sensing object of the device (mm)
However, the value of C cannot be under 0.
 $C = 8 \times (d - 14)$
d: Minimum sensing object diameter (mm)

<Reference>

- For calculating the safety distance S, there are the following five cases.
First calculate by substituting the value K = 2,000 (mm/sec.) in the equation above. Then, classify the obtained value of S into three cases, 1) $S < 100$, 2) $100 \leq S \leq 500$, and 3) $S > 500$. For Case 3) $S > 500$, recalculate by substituting the value K = 1,600 (mm/sec.). After that, classify the calculation result into two cases, 4) $S \leq 500$ and 5) $S > 500$.
For details, refer to "Calculation Example 1 For use in Europe."
- When this device is used in the "PSDI Mode," an appropriate safety distance S must be calculated.
For details, be sure to refer to the standards or regulations applicable in each region or country.

<In case that the minimum sensing object is over $\varnothing 40\text{mm}$ >

- Equation 1 $S = K \times T + C$
 - S : Safety distance (mm)
Minimum required distance between the sensing area surface and the dangerous parts of the machine
 - K : Intrusion velocity of operator's body or object (mm/sec.)
Taken as 1,600 (mm/sec.) for calculation
 - T : Response time of total equipment (sec.)
 $T = T_m + T_{SF4B}$
T_m : Maximum halting time of machine (sec.)
T_{SF4B} : Response time of this device (sec.)
 - C : Additional distance calculated from the size of the minimum sensing object of the device (mm)
 $C = 850$ (mm)

<Calculation Example>

- Calculation Example 1: For use in Europe
(OFF response time: 14ms or less, minimum sensing object diameter: 25mm)

First, calculate with $K=2,000$.

$$\begin{aligned} S &= K \times T + C \\ &= K \times (T_m + T_{SF4B}) + 8 \times (d - 14) \\ &= 2,000 \times (T_m + 0.014) + 8 \times (25 - 14) \\ &= 2,000 \times T_m + 2,000 \times 0.014 + 8 \times 11 \\ &= 2,000 \times T_m + 28 + 88 \\ &= 2,000 \times T_m + 116 \end{aligned}$$

If the result is:

- 1) In case $S < 100$ (mm)
Safety distance S is taken as 100 (mm)
- 2) In case $100 \leq S \leq 500$ (mm)
Safety distance S is taken as $2,000 \times T_m + 116$ (mm)
- 3) In case $S > 500$ (mm)
$$\begin{aligned} S &= K' \times (T_m + T_{SF4B}) + 8 \times (d - 14) \\ &= 1,600 \times (T_m + 0.014) + 8 \times (25 - 14) \\ &= 1,600 \times T_m + 1,600 \times 0.014 + 8 \times 11 \\ &= 1,600 \times T_m + 22.4 + 88 \\ &= 1,600 \times T_m + 110.4 \end{aligned}$$

then, calculate again.

If the result is:

- 4) In case $S < 500$ (mm)
Safety distance S is taken as 500 (mm)
- 5) In case $S > 500$ (mm)
Safety distance S is taken as $1,600 \times T_m + 110.4$ (mm)

In case this device is installed in a system with a maximum halting time of 0.1 (sec.)

$$\begin{aligned} S &= 2,000 \times T_m + 116 \\ &= 2,000 \times 0.1 + 116 \\ &= 316 \end{aligned}$$

Since this value matches with Case 2) above, S is 316 (mm)

In case this device is installed in a system with a maximum halting time of 0.4 (sec.)

$$\begin{aligned} S &= 2,000 \times T_m + 116 \\ &= 2,000 \times 0.4 + 116 \\ &= 916 \end{aligned}$$

Since this value matches with Case 3) above,

$$\begin{aligned} S &= 1,600 \times T_m + 110.4 \\ &= 1,600 \times 0.4 + 110.4 \\ &= 750.4 \end{aligned}$$

Since this value matches with Case 5) above, S is 750.4 (mm)

Protection Area

[For use in the United States of America (as per ANSI/RIA 15.06)]

- Equation 2 $D_s = K \times (T_s + T_c + T_{SF4B} + T_{bm}) + D_{pf}$
 - D_s : Safety distance (mm)
Minimum required distance between the sensing area surface and the dangerous parts of the machine
 - K : Intrusion speed {Recommended value in OSHA is 63 (inch/s) [$\approx 1,600$ (mm/sec.)]}
ANSI/RIA 15.06 does not define the intrusion speed "K". When determining K, consider possible factors including physical ability of operators.
 - T_s : Halting time calculated from the operation time of the control element (air valve, etc.) (sec.)
 - T_c : Maximum response time of the control circuit required for functioning the brake (sec.)
 - T_{SF4B} : Response time of this device (sec.)
 - T_{bm} : Additional halting time tolerance for the brake monitor (sec.)
The following equation holds when the machine is equipped with a brake monitor.
 $T_{bm} = T_a - (T_s + T_c)$
 T_a : Setting time of brake monitor (sec.)
When the machine is not equipped with a brake monitor, it is recommended that 20% or more of $(T_s + T_c)$ is taken as additional halting time.
 - D_{pf} : Additional distance calculated from the size of the minimum sensing object of the device (mm)
 - SF4B-H□C□** : $D_{pf} = 61.2\text{mm}$
 - SF4B-A□C□** : $D_{pf} = 129.2\text{mm}$
 - $D_{pf} = 3.4 \times (d - 0.276)$ (inch)
 $\approx 3.4 \times (d - 7)$ (mm)
 - d : Minimum sensing object diameter 0.985 (inch) ≈ 25 (mm) **SF4B-H□C□**
Minimum sensing object diameter 1.772 (inch) ≈ 45 (mm) **SF4B-A□C□**

<Calculation Example>

- Calculation Example 2 For use in the United States of America
[OFF response time: 14ms or less, minimum sensing object diameter: 0.985 (inch) ≈ 25 (mm)]
 - $D_s = K \times (T_s + T_c + T_{SF4B} + T_{bm}) + D_{pf}$
 - $= 63 \times (T_a + 0.014) + 3.4 \times (d - 0.276)$ (inch)
 - $= 63 \times (T_a + 0.014) + 3.4 \times (0.985 - 0.276)$
 - $= 63 \times T_a + 63 \times 0.014 + 3.4 \times 0.709$
 - $= 63 \times T_a + 0.882 + 2.4106$
 - $= 63 \times T_a + 3.2926$
 - $\approx 63 \times T_a + 3.29$ (inch)

In case this device is installed in a system with a maximum halting time of 0.1 (sec.)

$$\begin{aligned} D_s &= 63 \times T_a + 3.29 \\ &= 63 \times 0.1 + 3.29 \\ &= 9.59 \text{ (inch)} \\ &\approx 239.75 \text{ (mm)} \end{aligned}$$

Hence, as per the calculations D_s is 239.7 (mm).

<Reference>

- When the floating blanking function is applied, the minimum sensing object becomes large. According to ANSI B11.19, $D_{pf} = 900\text{mm}$ (3 ft) when $d > 64\text{mm}$ (2.5 inches).
- Since the calculation above is performed by taking 1 (inch) = 25.4 (mm), there is a slight difference between the representation in (mm) and that in (inch). Refer to the relevant standard for the details.

2-3-3 Influence of Reflective Surfaces

⚠ WARNING

If there exists a reflective surface in the place where this device is to be installed, make sure to install this device so that reflected light from the reflective surface does not enter into the receiver, or take countermeasures such as painting, masking, roughening, or changing the material of the reflective surface, etc. Failure to do so may cause the device not to detect, resulting in death or serious injury.

Install this device at a distance of at least A (m) (given below) away from reflective surfaces such as metal walls, floors, ceilings, workpieces, covers, panels or glass surfaces.

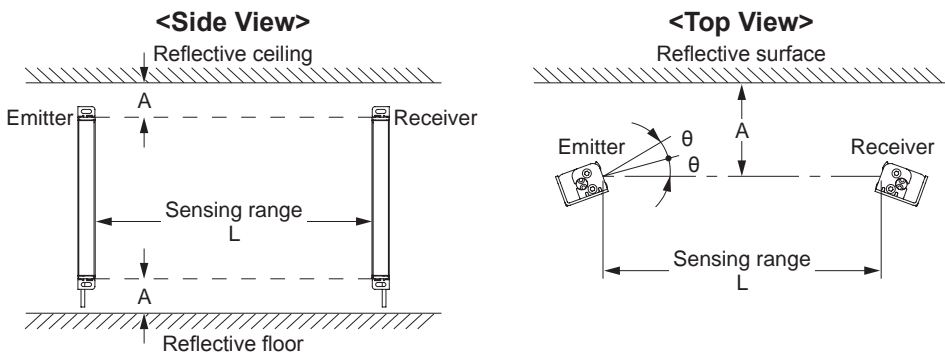

Distance between emitter and receiver (Sensing range L)	Allowable installation distance A
0.3 to 3m	0.16m
3 to 7m	$L/2 \times \tan 2\theta = L/2 \times 0.105 \text{ (m) } (\theta = 3^\circ)$

Note: The effective aperture angle for this device is $\pm 2.5^\circ$ or less (when $L > 3\text{m}$) as required by IEC 61496-2, ANSI/UL 61496-2. However, install this device away from reflective surfaces considering an effective aperture angle of $\pm 3^\circ$ to take care of beam misalignment, etc. during installation.

Allowable Distance from This Device to Reflective Surface

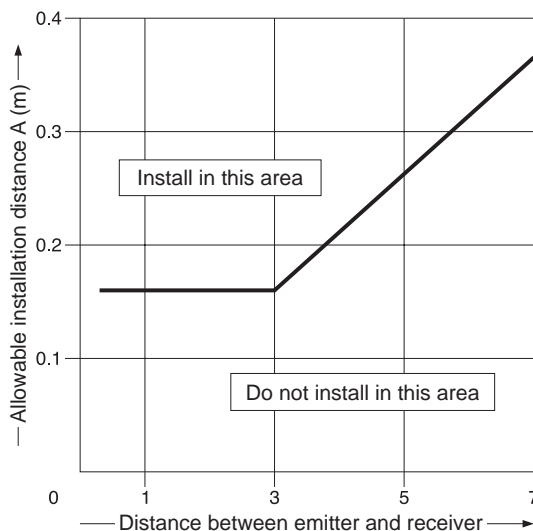

Protection Area

2-3-4 Device Placement

This is the configuration when two or more sets of emitter and receiver facing each other are placed. It is used for the case that there is a problem in wiring or for system evaluation in case of addition of equipment. Perform an operation test by referring to “2-6-2 Operation Test.”

WARNING

- Refer to the examples of device placement given below and understand them thoroughly before installing the devices. Improper sensor placement could cause device malfunction, which can result in death or serious injury.
- If this device is used in multiple sets, arrange them to avoid mutual interference. If mutual interference occurs, it can result in death or serious injury.

<Example of device placement>

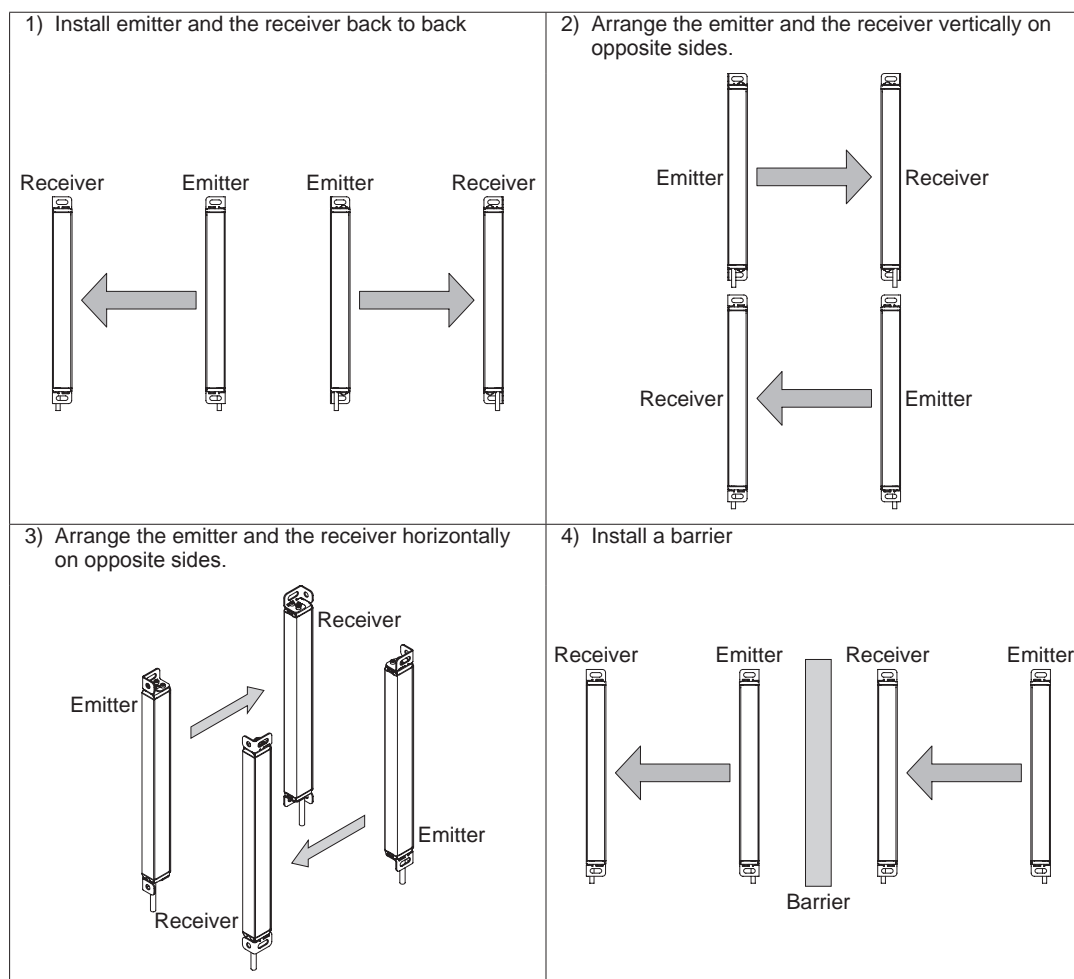

<Reference>

The above figures are just examples of device placement. If there are any questions or problems, please contact our office.

WARNING

Position the emitter and receiver so that their cables are aligned. Failure to do so will cause the system to malfunction.

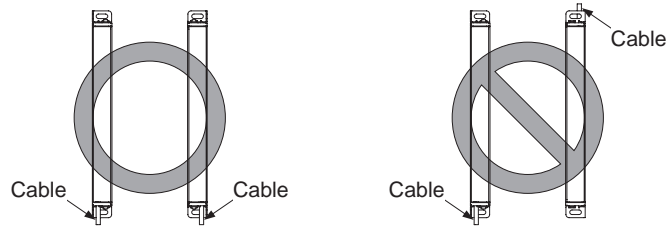

Mounting

2-4 Mounting

2-4-1 Mounting of the Mounting Bracket

 **CAUTION**

- Do not apply the load such as forced bending to the cable of this device. Applying improper load could cause the wire breakage.
- The minimum bending radius of the cable is R5mm. Mount the device considering the cable bending radius.
- After installing the product with the mounting brackets, verify that the incident light indicator is green.

<Reference>

- Mount the emitter and the receiver at the same level and parallel to each other. The effective aperture angle of this device is $\pm 2.5^\circ$ or less for a sensing distance of 3m or more.
- Unless otherwise specified, the following mounting procedure is common for both emitter and receiver. For the preparation of the mounting, prepare the mounting holes on the mounting surface by referring to "**6-3 Dimensions.**"

<In case of using standard mounting bracket MS-SF4BC-1 (optional)>

Step 1 Secure the bracket with two hexagon-socket head bolts [M3 (length: 5mm)]. The tightening torque should be 0.5N•m.

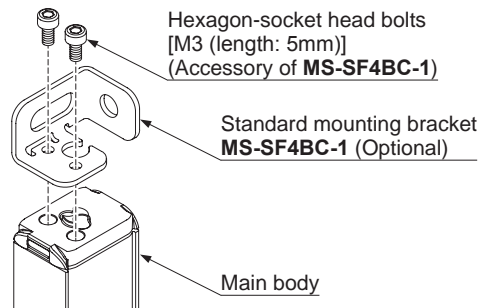

Step 2 Mount the standard mounting bracket on the mounting surface using hexagon-socket head bolts [M5 (purchase separately)].

<In case of rear mounting>

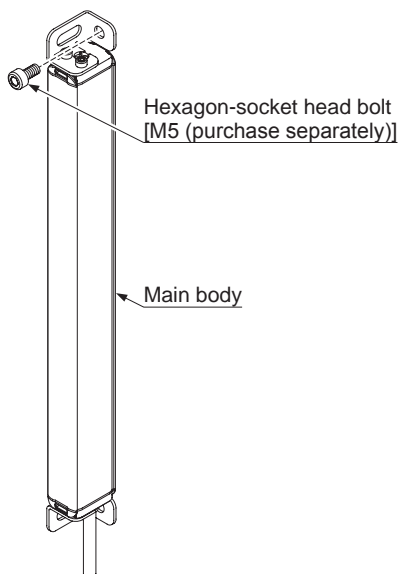

<In case of side mounting>

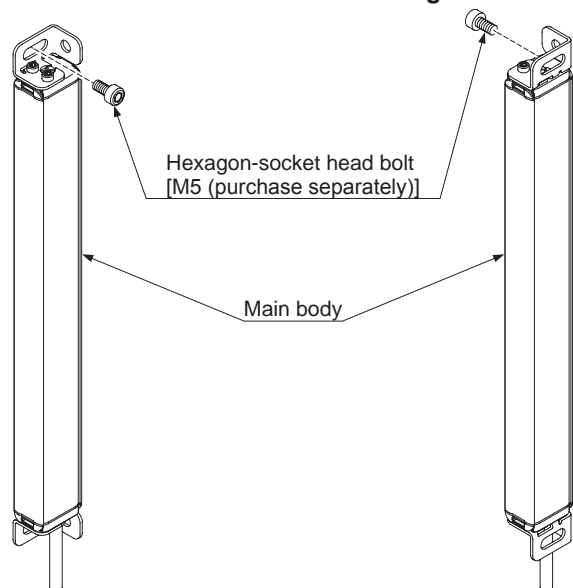

Note: Use M5 washers (accessory of MS-SF4BC-1) when mounting to an aluminum frame.

Mounting

<In case of using intermediate supporting bracket for use with standard mounting bracket MS-SF4BC-5 (optional)>

Step 1 Secure the bracket with two M3 flat head screws (purchase separately). The tightening torque should be 0.5N·m.

<In case of rear mounting>

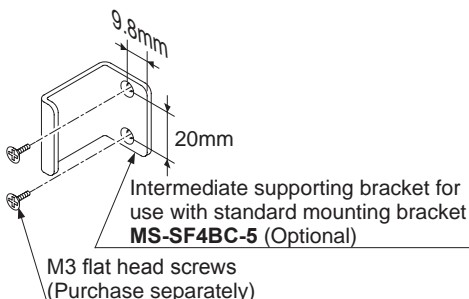

<In case of side mounting>

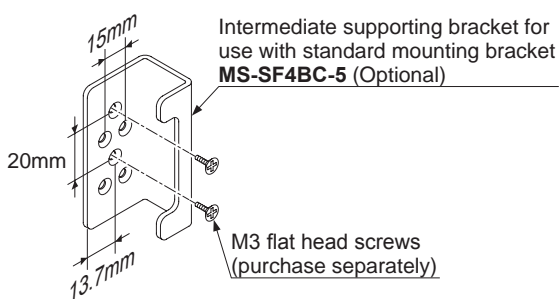

Step 2 Insert this device into the intermediate supporting bracket.

<In case of rear mounting>

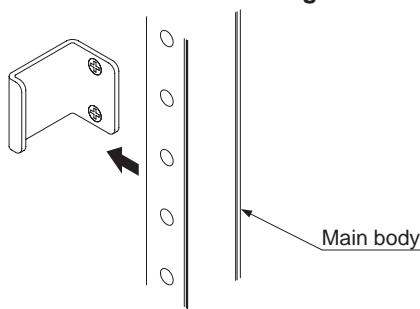

<In case of side mounting>

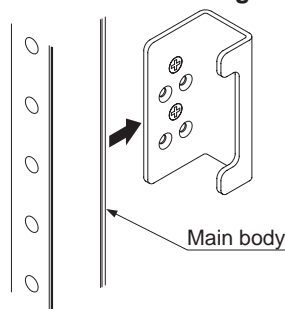

Note: **SF4B-H□C□**: 48 beam channels or more, **SF4B-A□C□**: 24 beam channels or more require intermediate supporting bracket for use with standard mounting bracket **MS-SF4BC-5** (optional).

SF4B-H40C□, SF4B-H48C□, SF4B-H56C□, SF4B-A20C□, SF4B-A24C□, SF4B-A28C□: 1 set
SF4B-H64C□, SF4B-H72C□, SF4B-H80C□, SF4B-H88C□, SF4B-H96C□, SF4B-A32C□, SF4B-A36C□, SF4B-A40C□, SF4B-A44C□, SF4B-A48C□: 2 sets

<In case of using rear utility mounting bracket MS-SF4BC-2 (optional)>

Step 1 Secure the bracket with two hexagon-socket head bolts [M3 (length: 6mm)]. The tightening torque should be 0.5N•m.

If installation space is limited, insert a hexagon head bolt [M5 (purchase separately)] into the rear utility mounting bracket and tighten with two hexagon-socket head bolts [M3 (length: 6mm)]. The tightening torque should be 0.5N•m.

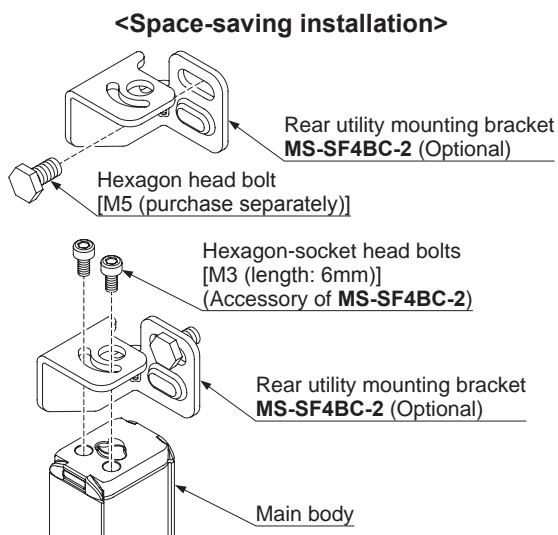
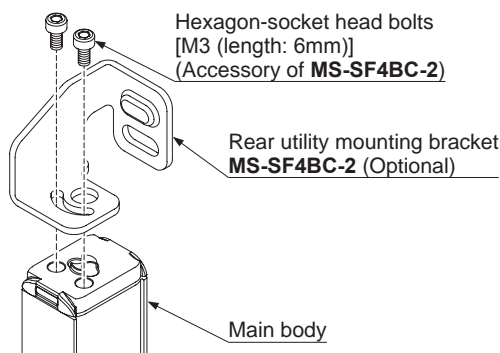

Step 2 Mount the rear utility mounting bracket on the mounting surface using hexagon-socket head bolts [M5 (purchase separately)].

If installation space is limited, tighten the hexagon head bolts to secure the product to the mounting surface.

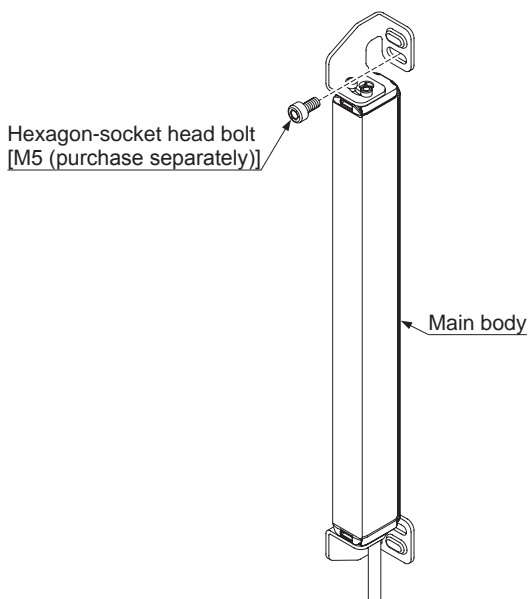

<Space-saving installation>

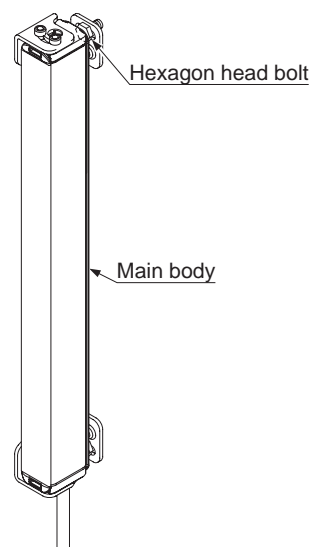

Note: Use M5 washers (accessory of MS-SF4BC-2) when mounting to an aluminum frame.

Mounting

<In case of using side utility mounting bracket MS-SF4BC-3 (optional)>

Step 1 Secure the bracket with two hexagon-socket head bolts [M3 (length: 6mm)]. The tightening torque should be 0.5N•m.

If installation space is limited, insert a hexagon head bolt [M5 (purchase separately)] into the side utility mounting bracket and tighten with two hexagon-socket head bolts [M3 (length: 6mm)]. The tightening torque should be 0.5N•m.

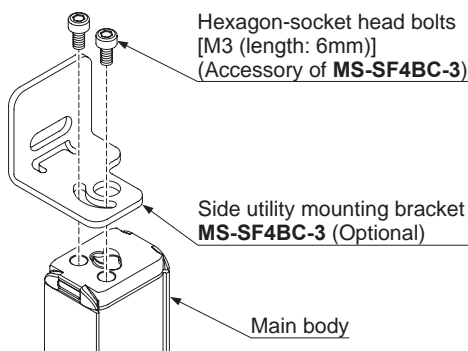

<Space-saving installation>

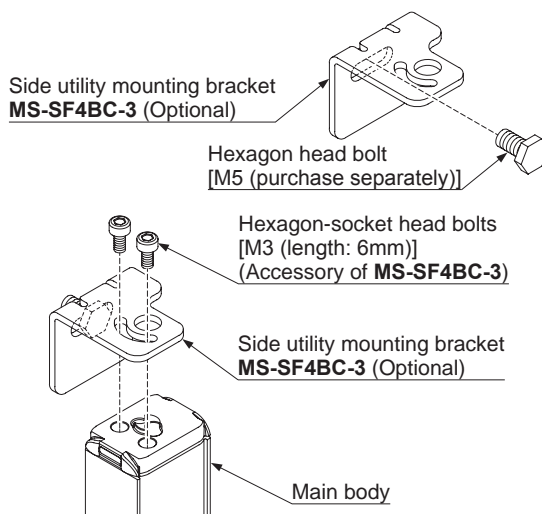

Step 2 Mount the side utility mounting bracket on the mounting surface using hexagon-socket head bolts [M5 (purchase separately)].

If installation space is limited, tighten the hexagon head bolts to secure the product to the mounting surface.

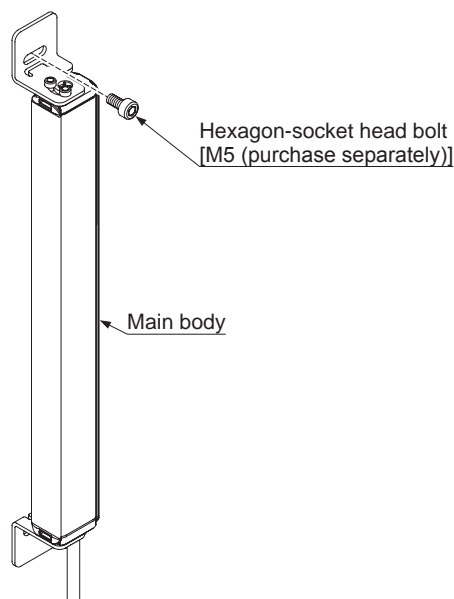

<Space-saving installation>

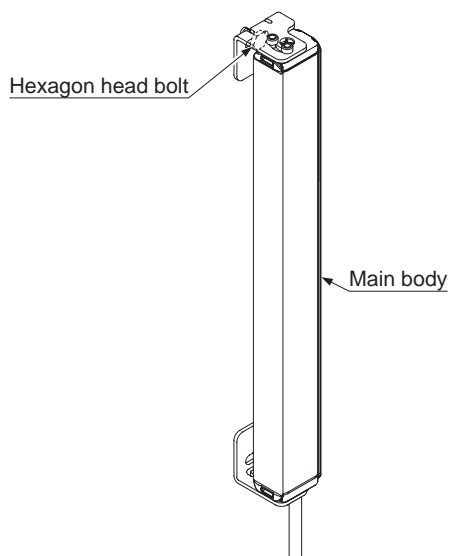

Note: Use M5 washers (accessory of MS-SF4BC-3) when mounting to an aluminum frame.

<In case of using intermediate supporting bracket for use with utility mounting bracket MS-SF4BC-4 (optional)>

Step 1 Loosen the hexagon-socket head bolt [M3 (length: 6mm)] holding the intermediate supporting bracket for use with rear-mounted installations in place and take the bracket apart.

<Intermediate supporting bracket for use with rear-mounted installations>

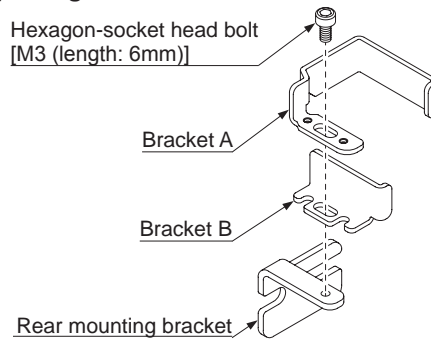

Step 2 Insert bracket A from the rear of the device.

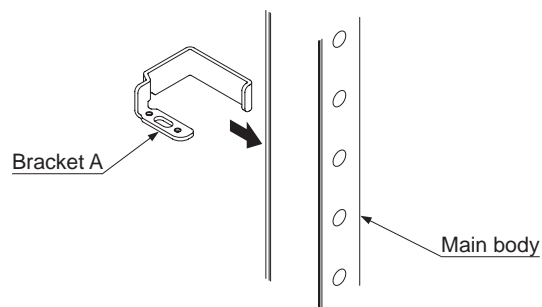

Step 3 Insert bracket B into the gap between the device and bracket A.

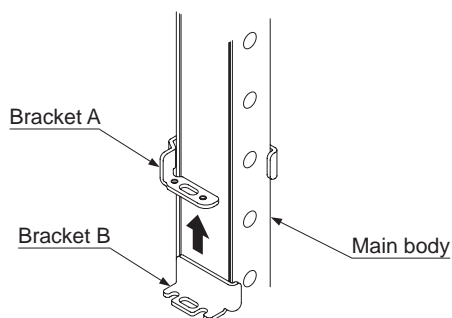

Mounting

Step 4 Choose either the rear mounting bracket or the side mounting bracket.

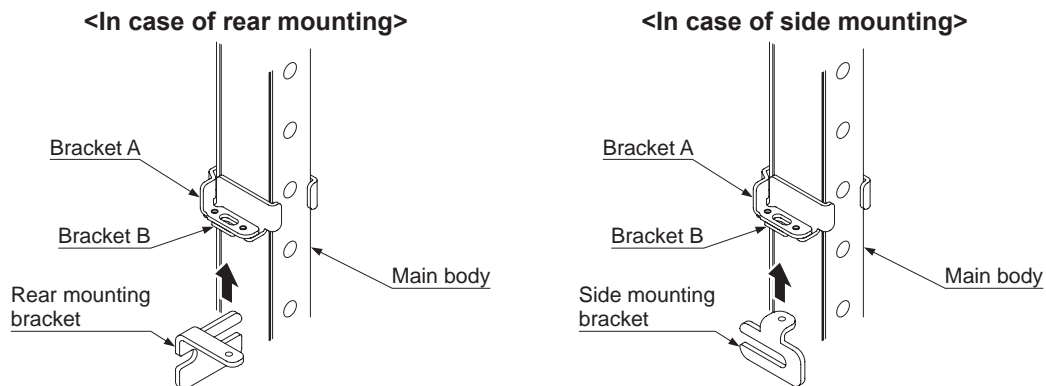

Step 5 Secure bracket A, bracket B, and either the rear mounting bracket or side mounting bracket in place with a hexagon-socket head bolt [M3 (length: 6mm)]. The tightening torque should be 0.5N•m.

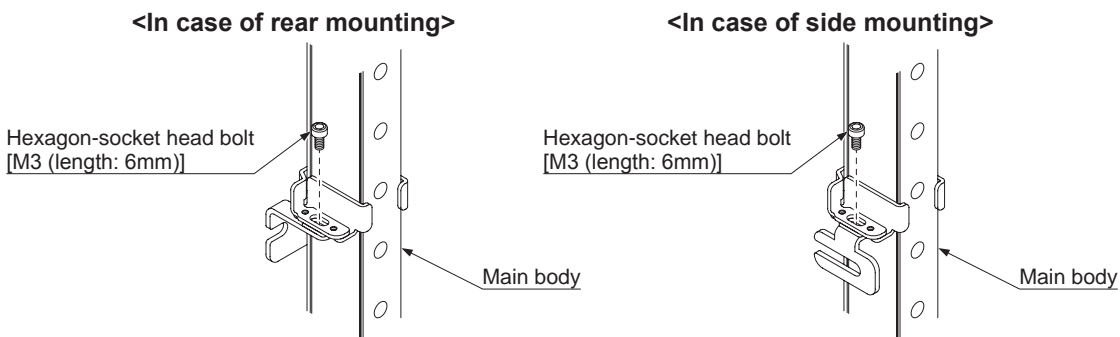

Step 6 Temporarily secure a hexagon head bolt [M5 (purchase separately)] to the mounting surface.

Step 7 Slide the device so that the rear mounting bracket or side mounting bracket fits around the hexagon head bolt.

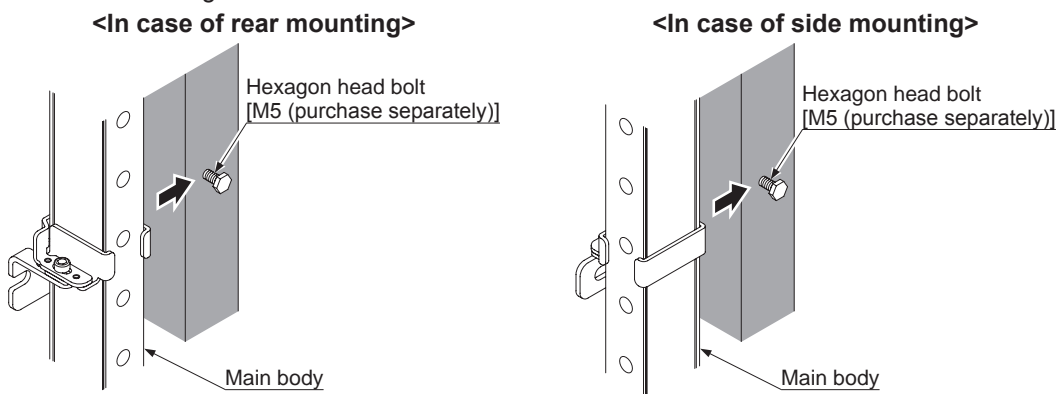

Note: **SF4B-H□C□**: 48 beam channels or more, **SF4B-A□C□**: 24 beam channels or more require intermediate supporting bracket for use with utility mounting bracket **MS-SF4BC-4** (optional).
SF4B-H40C□, **SF4B-H48C□**, **SF4B-H56C□**, **SF4B-A20C□**, **SF4B-A24C□**, **SF4B-A28C□**: 1 set
SF4B-H64C□, **SF4B-H72C□**, **SF4B-H80C□**, **SF4B-H88C□**, **SF4B-H96C□**, **SF4B-A32C□**, **SF4B-A36C□**,
SF4B-A40C□, **SF4B-A44C□**, **SF4B-A48C□**: 2 sets

<In case of using side mounting bracket MS-SF4BC-6 (optional)>

Step 1 Secure the bracket with two hexagon-socket head bolts [M3 (length: 6mm)]. The tightening torque should be 0.5N•m.

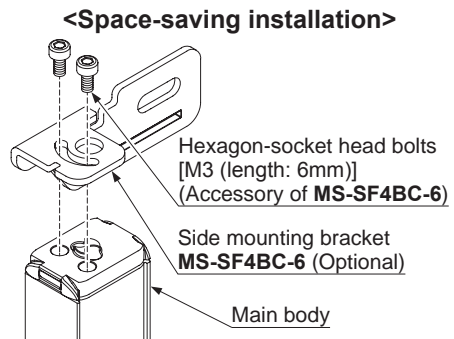
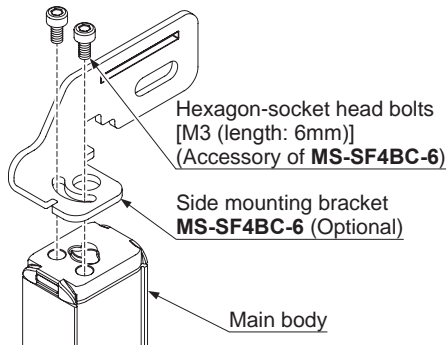

Step 2 Mount the side mounting bracket on the mounting surface using hexagon-socket head bolts [M5 (purchase separately)].

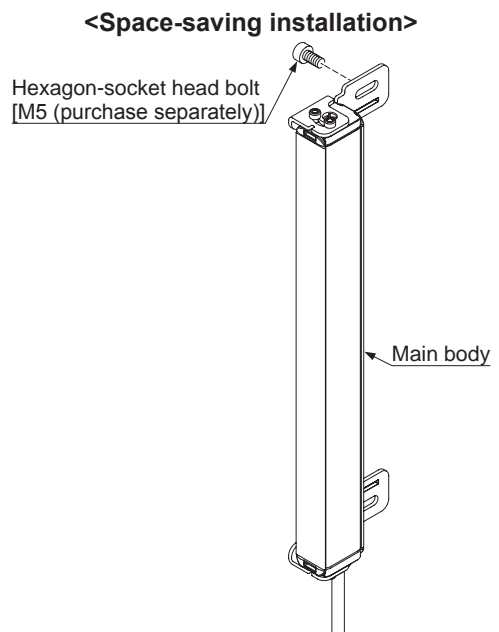
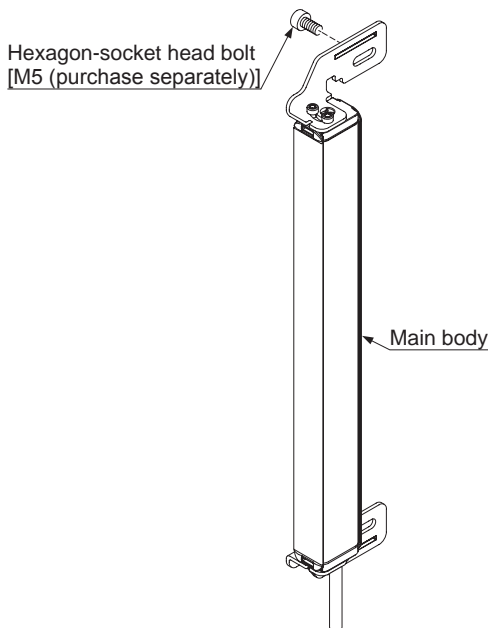

- Notes: 1) Use M5 washers (accessory of MS-SF4BC-6) when mounting to an aluminum frame.
 2) When mounting a side mounting bracket MS-SF4BC-6 (optional) to an aluminum frame, etc., pay attention to the mounting direction.

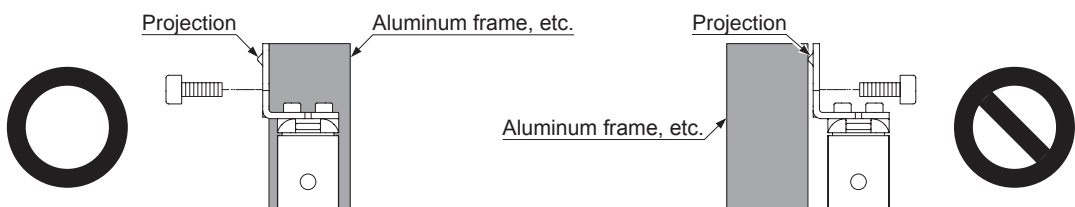

Mounting

<Reference>

- When mounting to an aluminum frame, refer to the positioning mark on a side mounting bracket **MS-SF4BC-6** (optional), in accordance with the shape of the aluminum frame.

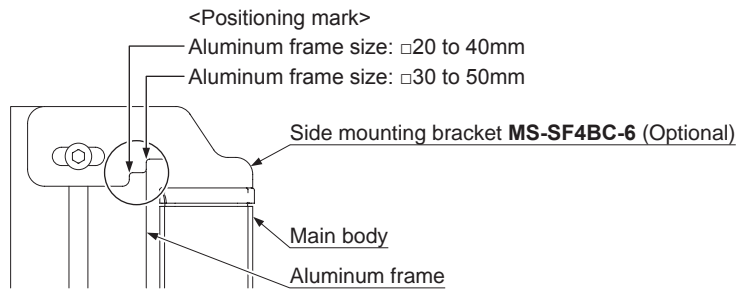

- When mounting to elsewhere, refer to the following figure for installation.

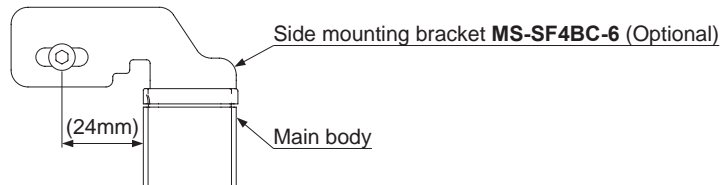

<In case of using intermediate supporting bracket for use with side mounting bracket MS-SF4BC-7 (optional)>

Step 1 Loosen the hexagon-socket head bolt [M3 (length: 6mm)] holding the intermediate supporting bracket for use with side mounting bracket in place and take the bracket apart.

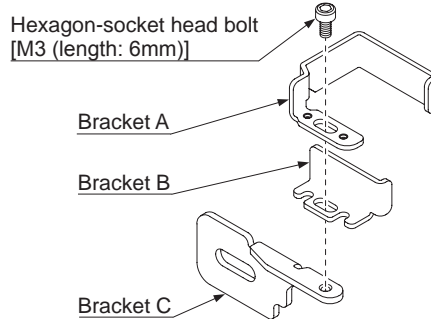

Step 2 Insert bracket A from the rear of the device.

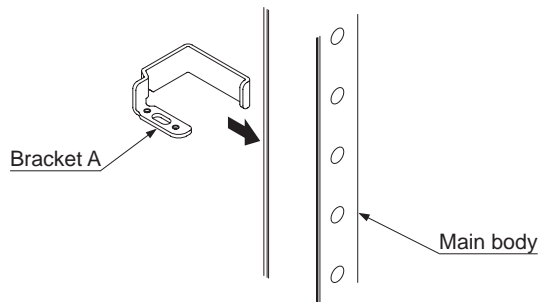

Step 3 Insert bracket B into the gap between the device and bracket A.

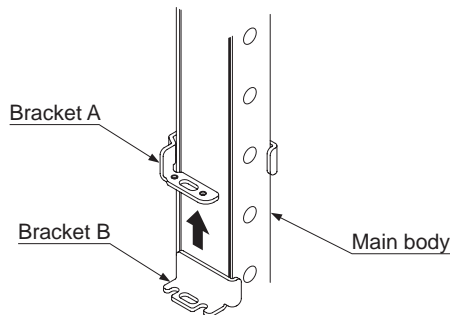

Step 4 Match the hole in bracket C with the hole in bracket B.

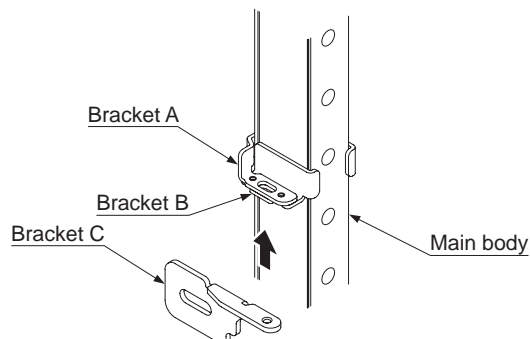

Mounting

Step 5 Secure bracket A, bracket B, and bracket C in place with a hexagon-socket head bolt [M3 (length: 6mm)].

The tightening torque should be 0.5N•m.

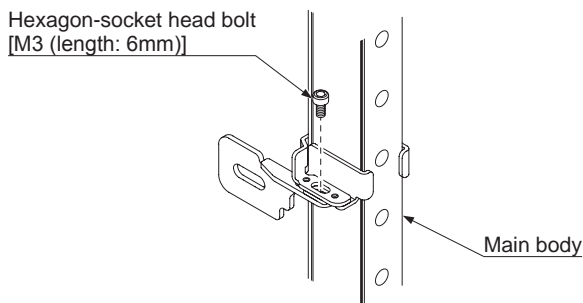

Step 6 Mount the intermediate supporting bracket for use with side mounting bracket on the mounting surface using hexagon-socket head bolts [M5 (purchase separately)].

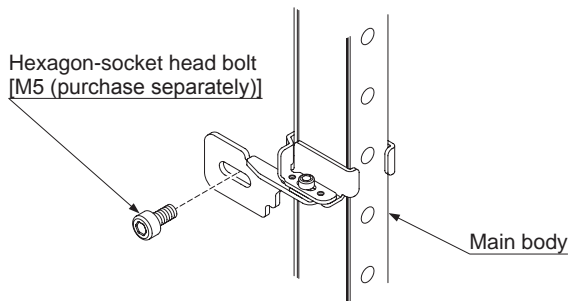

Note: **SF4B-H□C□**: 48 beam channels or more, **SF4B-A□C□**: 24 beam channels or more require intermediate supporting bracket for use with side mounting bracket **MS-SF4BC-7** (optional).

SF4B-H40C□, **SF4B-H48C□**, **SF4B-H56C□**, **SF4B-A20C□**, **SF4B-A24C□**, **SF4B-A28C□**: 1 set

SF4B-H64C□, **SF4B-H72C□**, **SF4B-H80C□**, **SF4B-H88C□**, **SF4B-H96C□**, **SF4B-A32C□**, **SF4B-A36C□**,

SF4B-A40C□, **SF4B-A44C□**, **SF4B-A48C□**: 2 sets

<Reference>

- When mounting to an aluminum frame, refer to the positioning mark on an intermediate supporting bracket for use with side mounting bracket **MS-SF4BC-7** (optional), in accordance with the shape of the aluminum frame.

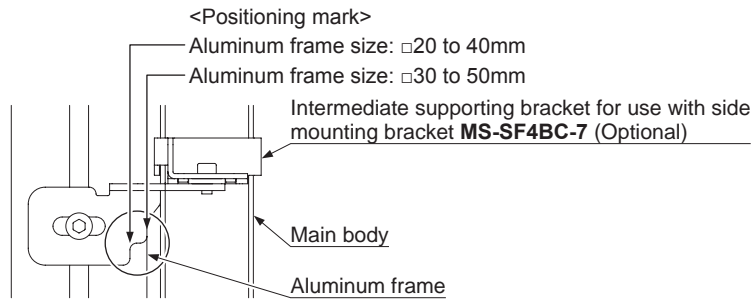

- When mounting to elsewhere, refer to the following figure for installation.

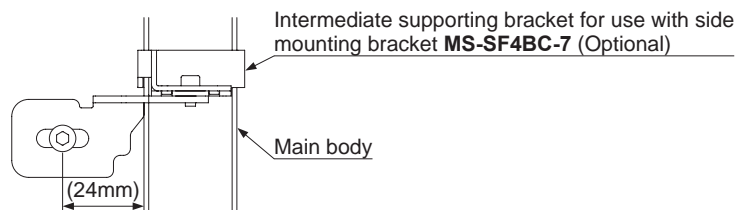

Mounting

<In case of using protective metal case MS-SF4BCH-□ (optional)>

⚠ CAUTION

In the case of using a protective metal case **MS-SF4BCH-□** (optional), make sure to assemble it with a standard mounting bracket **MS-SF4BC-1** (optional).

Step 1 Check that the standard mounting bracket **MS-SF4BC-1** (optional) is not attached to the machine, and insert the protective metal case **MS-SF4BCH-□** (optional) from above the machine.

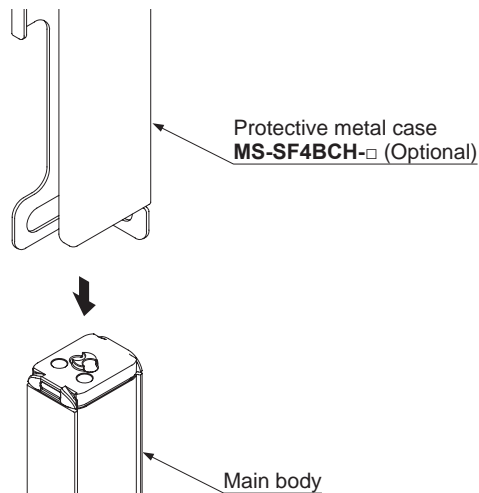

Step 2 Mount the standard mounting bracket to the machine using two hexagon-socket head bolts [M3 (length: 5 mm)].
The tightening torque should be 0.5N•m.

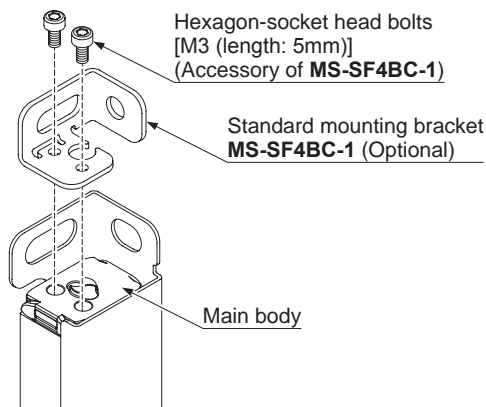

Step 3 Align the mounting hole of the protective metal case with that of the standard mounting bracket, and assemble to the mounting face using hexagon-socket head bolts [M5 (please prepare separately)].

<In case of rear mounting>

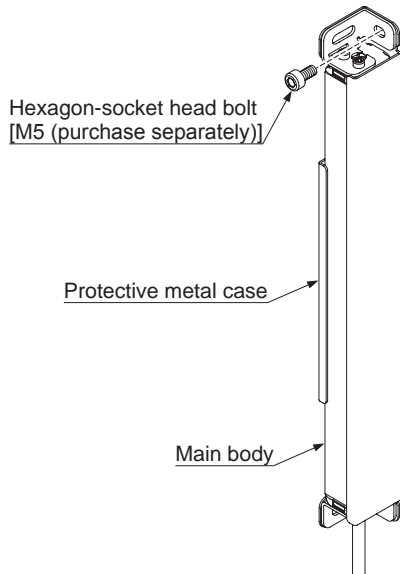

<In case of side mounting>

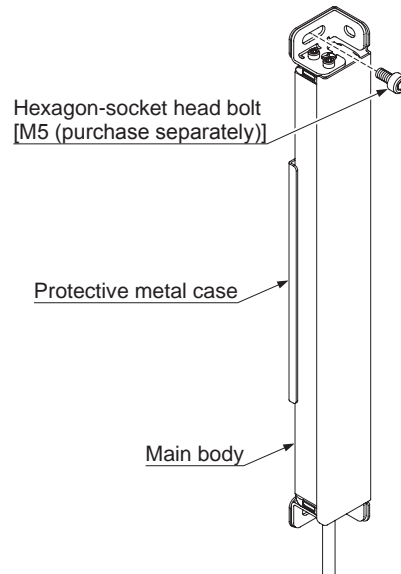

- Notes: 1) Use M5 washers (accessory of **MS-SF4BC-1**) when mounting to an aluminum frame.
2) Be careful to prevent the machine from slipping out of the protective metal case while assembling it to the mounting face.

Wiring

2-5 Wiring

WARNING

- Earth the machine or the support where the device is mounted on to frame ground (F.G.). Failure to do so could cause the malfunction of the device by noise, resulting in death or serious injury. Furthermore, the wiring should be done in a metal box connected to the frame ground (F.G.).
- Take countermeasure against the system to be applied for this device so as not to carry out the dangerous performance caused by the earth failure. Failure to do so could cause invalid for the system stop, resulting in death or serious injury.
- In order that the output is not turned ON due to earth fault of control output (OSSD 1 / 2) wires, be sure to ground to 0V side (PNP output) / +24V side (NPN output).
- When using this device in Korea with S-mark, make sure to ground to 0V side (PNP output).

CAUTION

Make sure to insulate the ends of the unused lead wires.

<Reference>

Use a safety relay unit or an equivalent control circuit in safety for FSD.

2-5-1 Power Supply Unit

CAUTION

Wire correctly using a power supply unit which conforms to the laws and standards of the region where this device is to be used.
If the power supply unit is non-conforming or the wiring is improper, it can cause damage or malfunction of this device.

<Reference>

A specialist who has the required electrical knowledge should perform the wiring.

The power supply unit must satisfy the conditions given below.

- 1) Power supply unit authorized in the region where this device is to be used.
- 2) Power supply unit SELV (safety extra low voltage) / PELV (protected extra low voltage) conforming to EMC Directive and Low-voltage Directive (only for requiring CE marking conformation).
- 3) Power supply unit conforming to the Low-voltage Directive and with an output of 100VA or less.
- 4) The frame ground (F.G.) terminal must be connected to ground when using a commercially available switching regulator.
- 5) Power supply unit with an output holding time of 20ms or more.
- 6) In case a surge is generated, take countermeasures such as connecting a surge absorber to the origin of the surge.
- 7) Power supply unit corresponding to CLASS 2 (only for requiring cTÜVus Mark conformation).

2-5-2 I/O Circuit Diagrams and Output Waveform

<In case of using I/O circuit for PNP output with SF4B-□C>

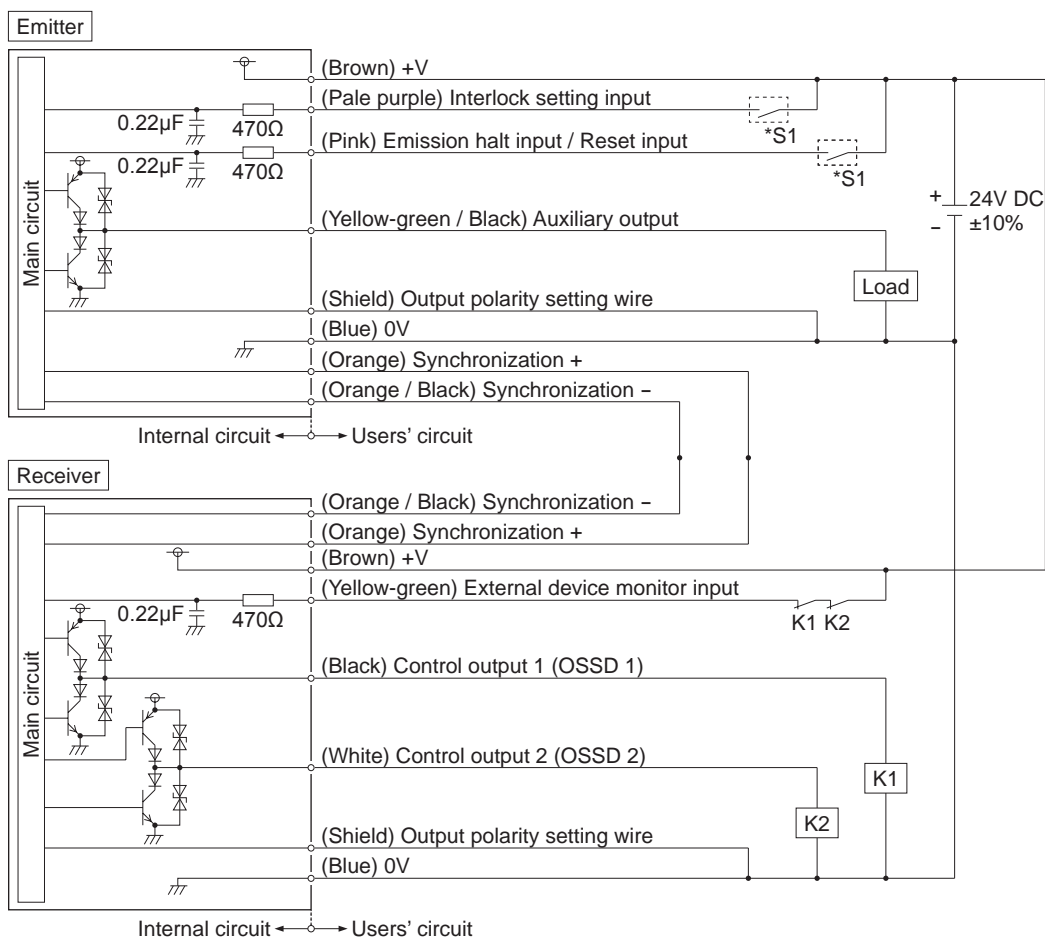

***S1**

Switch S1

- Emission halt input / Reset input

For manual reset ... Vs to Vs - 2.5V (sink current 5mA or less) : Emission halt (Note), Open: Emission
 For auto-reset ... Vs to Vs - 2.5V (sink current 5mA or less) : Emission (Note), Open: Emission halt

- Interlock setting input

Vs to Vs - 2.5V (sink current 5mA or less): Valid (Note), Open: Invalid

Note: Vs is the applying supply voltage.

<Reference>

- K1, K2: External device (Forced guided relay or magnetic contactor)
- For more information about wiring, refer to Section 2-5-4 and subsequent sections.

Wiring

<In case of using I/O circuit for NPN output with SF4B-□C>

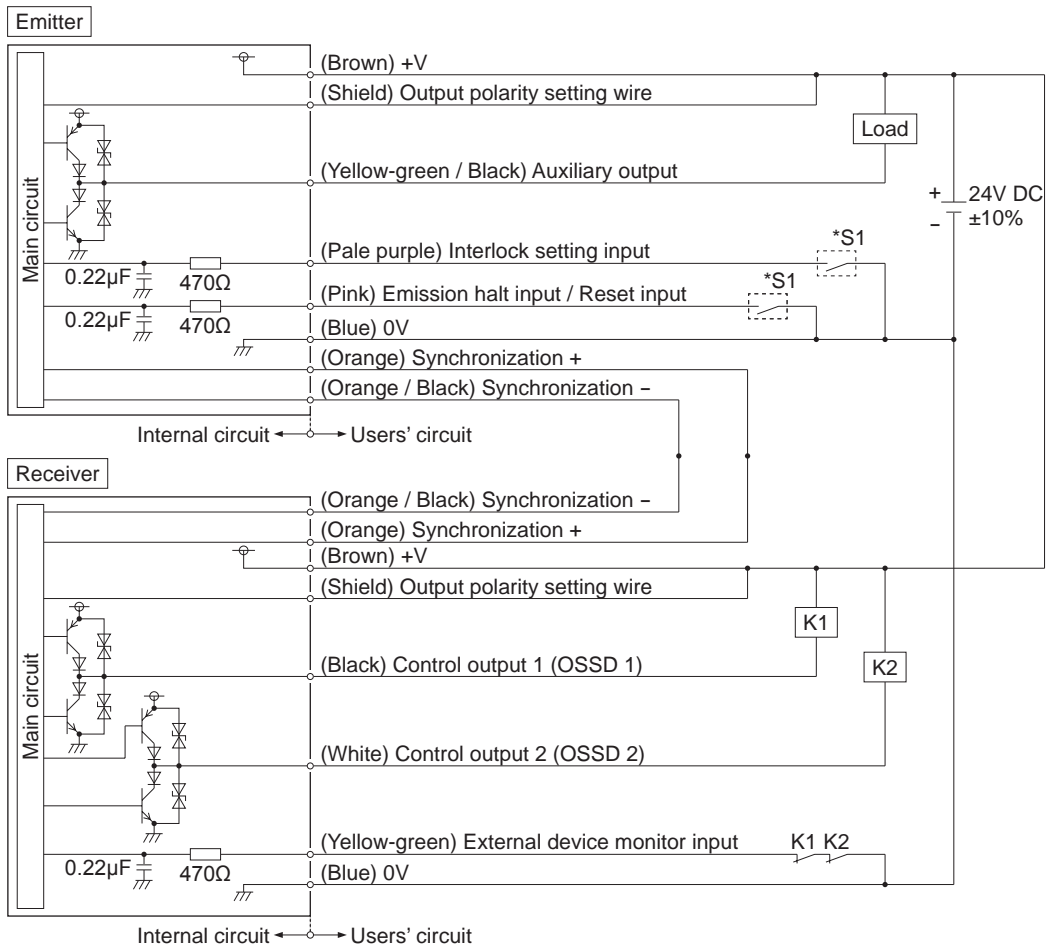

*S1

Switch S1

- Emission halt input / Reset input

For manual reset ... 0 to +1.5V (source current 5mA or less): Emission halt, Open: Emission

For auto-reset ... 0 to +1.5V (source current 5mA or less): Emission, Open: Emission halt

- Interlock setting input

0 to +1.5V (source current: 5mA or less): Valid, Open: Invalid

<Reference>

- K1, K2: External device (Forced guided relay or magnetic contactor)
- For more information about wiring, refer to Section 2-5-4 and subsequent sections.

<In case of using I/O circuit for PNP output with SF4B-□CA-J05>

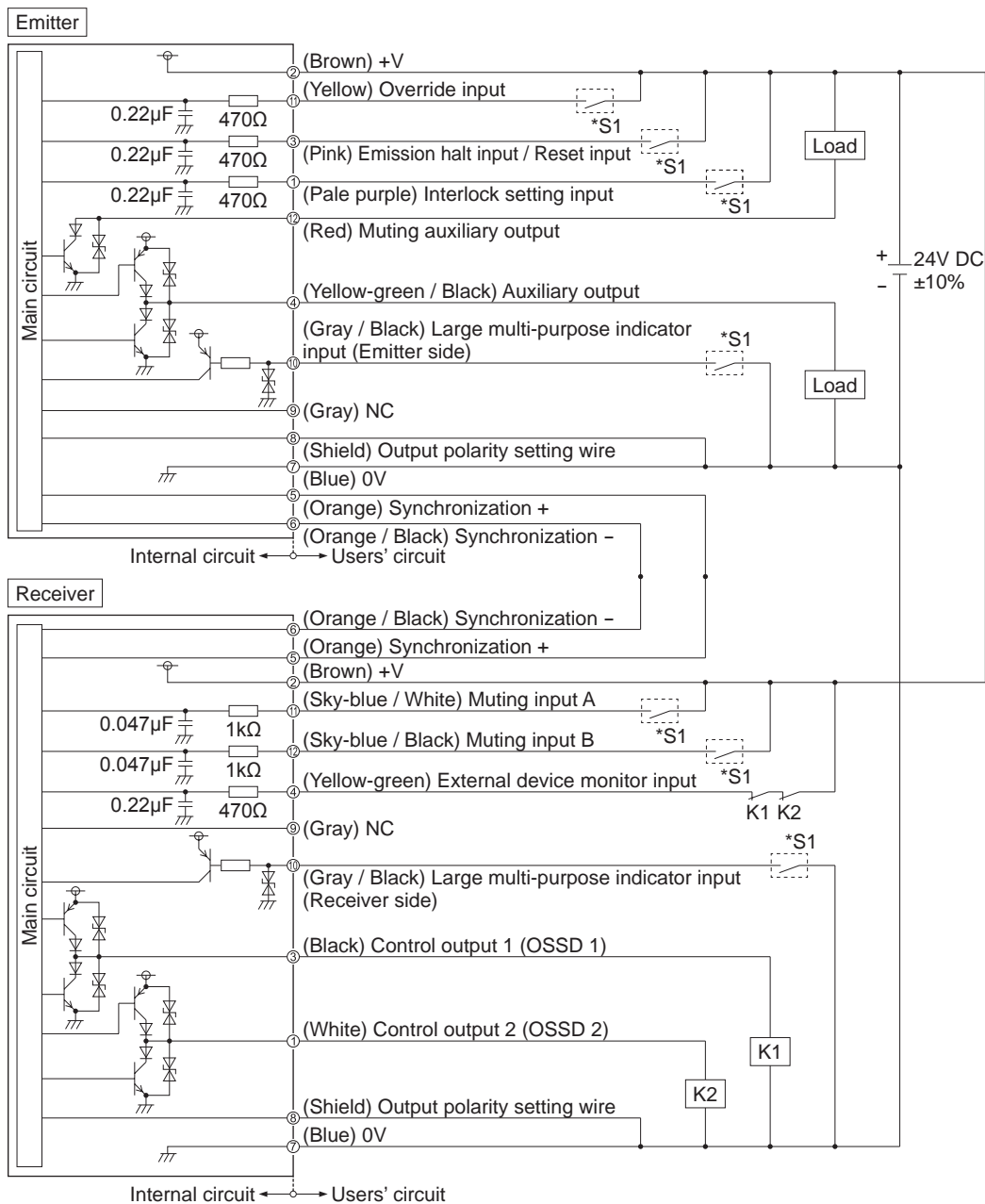

Wiring

*S1

Switch S1

- Emission halt input / Reset input
For manual reset ... Vs to Vs - 2.5V (sink current 5mA or less) : Emission halt (Note), Open: Emission
For auto-reset ... Vs to Vs - 2.5V (sink current 5mA or less) : Emission (Note), Open: Emission halt
- Interlock setting input, Override input, Muting input A / B, External device monitor input
Vs to Vs - 2.5V (sink current 5mA or less): Valid (Note), Open: Invalid
- Large multi-purpose indicator input
0 to + 1.5V (source current: 5mA or less): Lights up, Open: Turn OFF

Note: Vs is the applying supply voltage.

<Reference>

- K1, K2: External device (Forced guided relay or magnetic contactor)
- For more information about wiring, refer to Section 2-5-4 and subsequent sections.

<In case of using I/O circuit for NPN output with SF4B-□CA-J05>

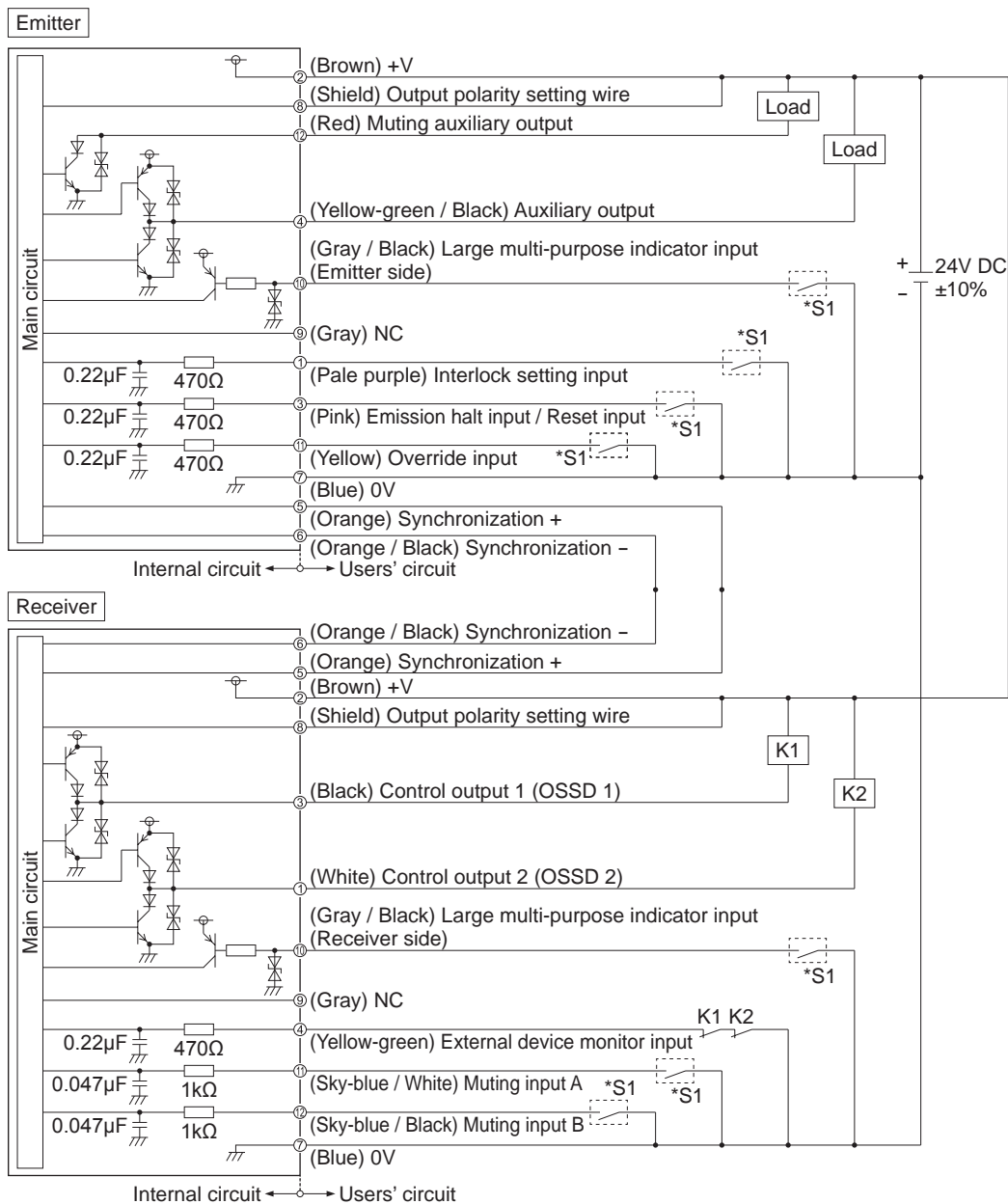

Wiring

*S1

Switch S1

- Emission halt input / Reset input
For manual reset ... 0 to +1.5V (source current 5mA or less): Emission halt, Open: Emission
For auto-reset ... 0 to +1.5V (source current 5mA or less): Emission, Open: Emission halt
- Interlock setting input, Override input, Muting input A / B, External device monitor input
0 to + 1.5V (source current: 5mA or less): Valid, Open: Invalid
- Large multi-purpose indicator input
0 to + 1.5V (source current: 5mA or less): Lights up, Open: Turn OFF

<Reference>

- K1, K2: External device (Forced guided relay or magnetic contactor)
- For more information about wiring, refer to Section 2-5-4 and subsequent sections.

<Output waveform [control output (OSSD 1 / 2) ON]>

Since the receiver performs the self-diagnosis of the output circuit when the device is in light receiving status (ON status), the output transistor becomes OFF status periodically. (Refer to the figure below.)

When the OFF signal is fed back, the receiver judges the output circuit as normal. When the OFF signal is not fed back, the receiver judges either the output circuit or wiring as error, and the control output (OSSD 1 / 2) maintains OFF status.

⚠ CAUTION

Perform the wiring with paying attention to the input response time of the machine to be connected to this device, since the OFF signal of this device might cause malfunction.

<Timing chart>

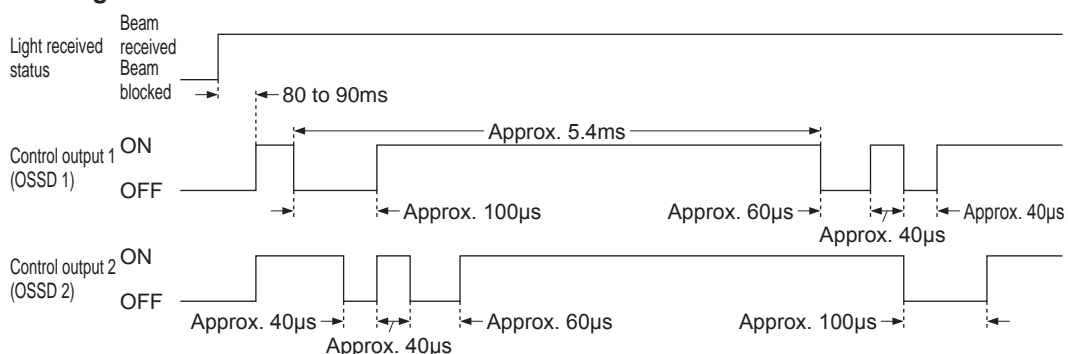

2-5-3 Wiring · Connecting Procedure and Connector Pin Arrangement

Connect the connector on the mating cable to the connector cable on the **SF4B-□CA-J05** device (emitter and receiver).

Wire the other side of the mating cable according to the customer's application referring to the connector pin arrangement given below.

⚠ WARNING

- When extending the cable, use the exclusive cable up to the total length of 50m (for each emitter / receiver). Extending the cable longer than 50m may cause malfunction, which can result in death or serious injury.
- When the synchronization + wire (orange) and synchronization - wire (orange / black) is extended with a cable other than exclusive cable, use a 0.2mm² or more shielded twisted pair cable.

Wiring

Extension cable with connector on one end

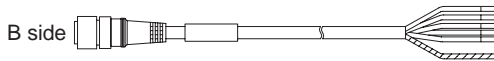

Connector at A side (for emitter / receiver)

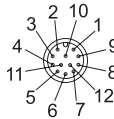

Extension cable with connector on both ends

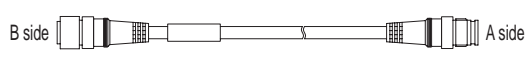

Connector at B side (for emitter / receiver)

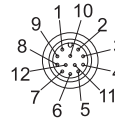

<12-core cable (SFB-CC□-MU)>

	Cable / connector color	Connector Pin No.	Color code	Description
Emitter	Gray / Gray	1	Pale purple	Interlock setting input
		2	Brown	24V DC
		3	Pink	Emission halt input / Reset input
		4	Yellow-green / Black	Auxiliary output
		5	Orange	Synchronization +
		6	Orange / Black	Synchronization -
		7	Blue	0V
		8	(Shield)	Output polarity setting wire
		9	Gray	NC
		10	Gray / Black	Large multi-purpose indicator input (Emitter side)
		11	Yellow	Override input
		12	Red	Muting auxiliary output
Receiver	Gray (with black stripe) / Black	1	White	Control output 2 (OSSD 2)
		2	Brown	24V DC
		3	Black	Control output 1 (OSSD 1)
		4	Yellow-green	External device monitor input
		5	Orange	Synchronization +
		6	Orange / Black	Synchronization -
		7	Blue	0V
		8	(Shield)	Output polarity setting wire
		9	Gray	NC
		10	Gray / Black	Large multi-purpose indicator input (Receiver side)
		11	Sky-blue / White	Muting input A
		12	Sky-blue / Black	Muting input B

<Reference>

- The connectors can be distinguished from their colors as follows:
Connector for emitter: gray, connector for receiver: black
- For details of the cable with connector on one end, and the cable with connector on both ends, refer to "6-2 Options."

2-5-4 Basic Wiring

This is the general configuration using one set of the emitter and receiver facing each other. The control output (OSSD 1 / 2) turns OFF if the light is blocked, while it automatically turns ON if it receives the light.

The auxiliary output is used to invalid the external device monitor function. At this time, set the auxiliary output with “negative logic of the control output” (factory setting). The auxiliary output cannot be connected to external devices.

<In case of using I/O circuit for PNP output with SF4B-□C>

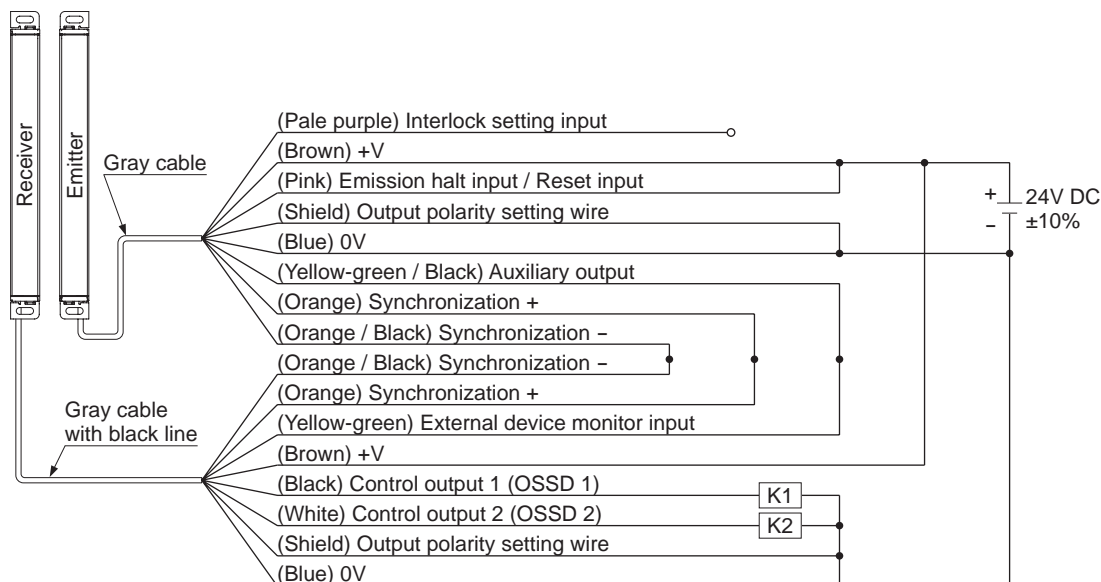

Interlock function	Invalid (Auto-reset)
External device monitor function	Invalid
Auxiliary output	Cannot be used

Wiring

<In case of using I/O circuit for NPN output with SF4B-□C>

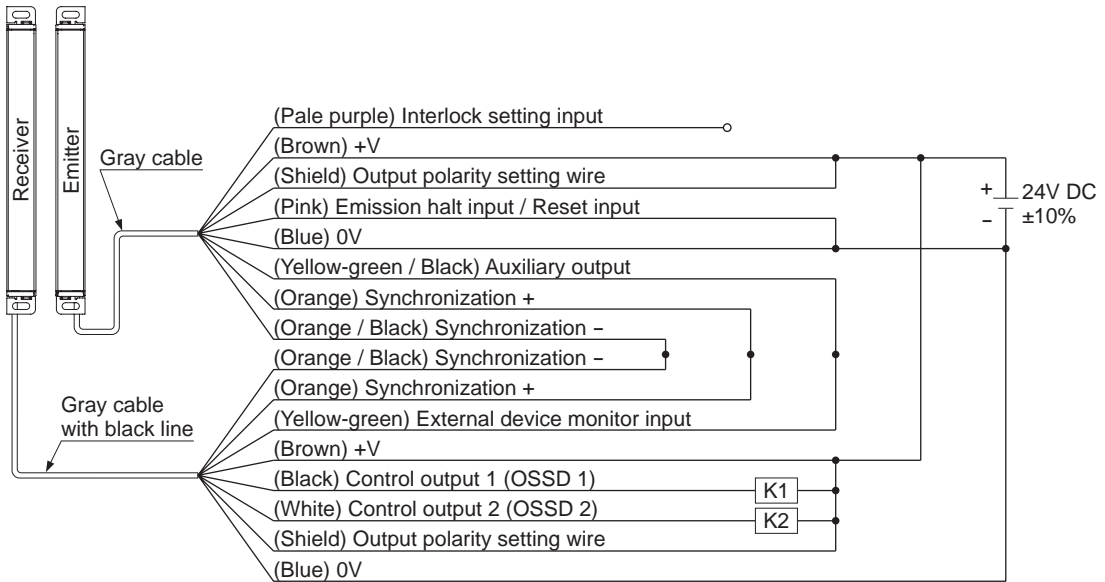

Interlock function	Invalid (Auto-reset)
External device monitor function	Invalid
Auxiliary output	Cannot be used

<In case of using I/O circuit for PNP output with SF4B-□CA-J05>

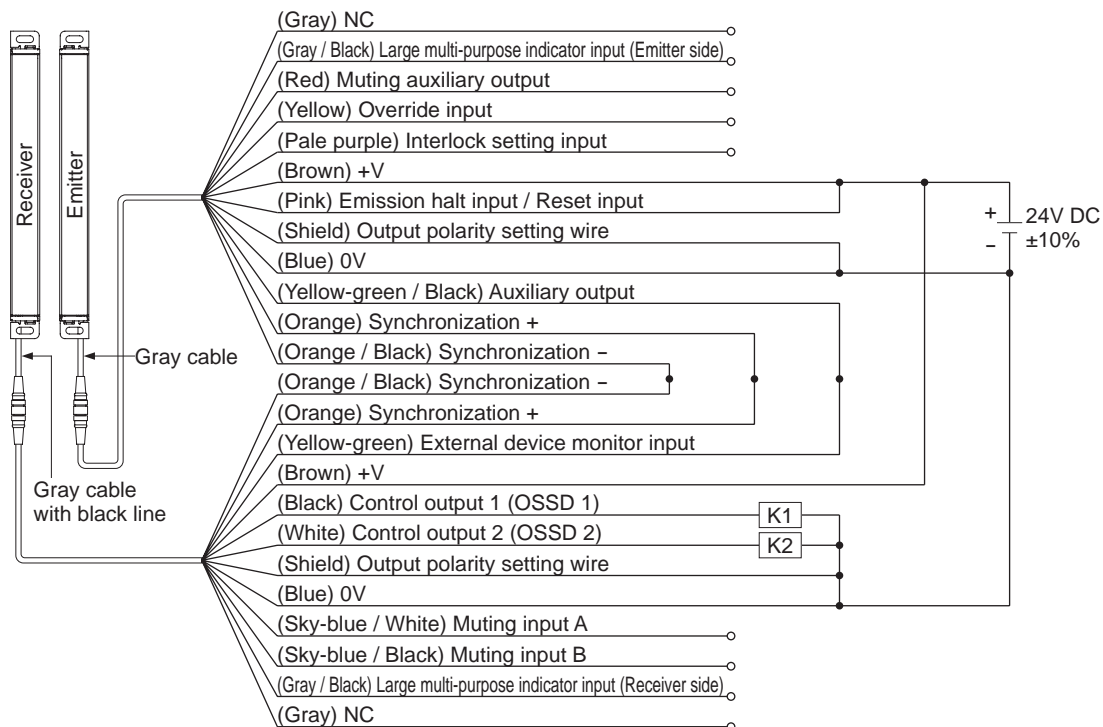

Interlock function	Invalid (Auto-reset)
External device monitor function	Invalid
Auxiliary output	Cannot be used

Wiring

<In case of using I/O circuit for NPN output with SF4B-□CA-J05>

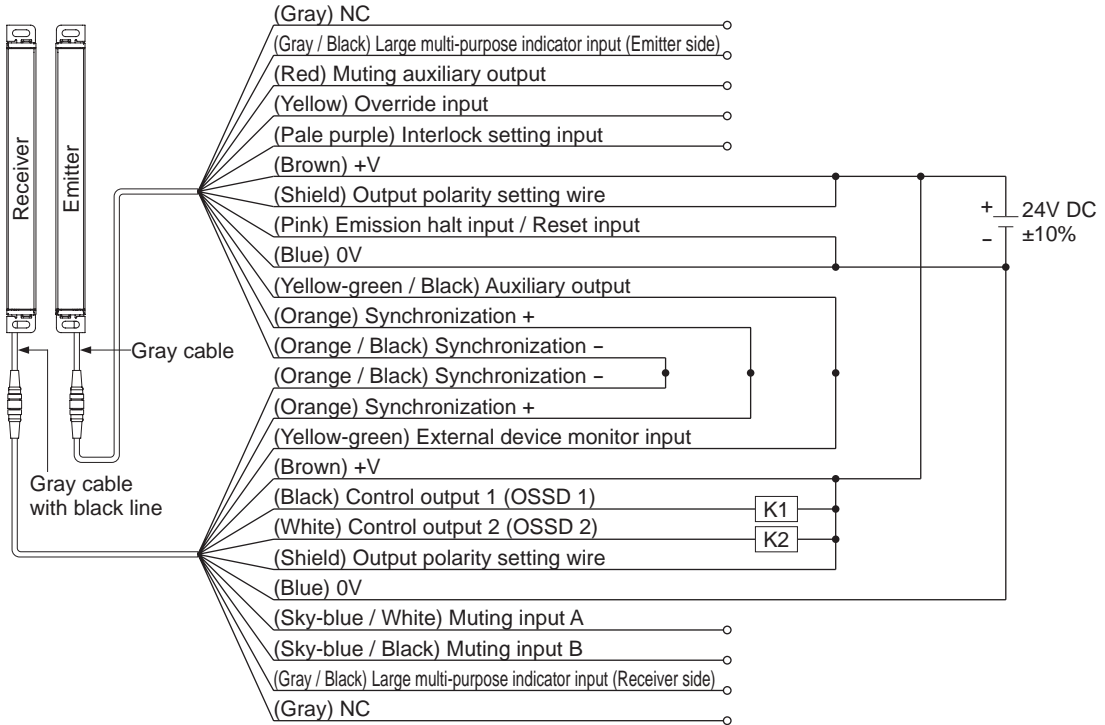

Interlock function	Invalid (Auto-reset)
External device monitor function	Invalid
Auxiliary output	Cannot be used

2-5-5 Wiring for Manual Reset (Interlock is Valid) (Wiring Example of the Control Category 4)

This is the general configuration using one set of the emitter and receiver facing each other. The control output (OSSD 1 / 2) turns OFF if the light is blocked.

<In case of using I/O circuit for PNP output with SF4B-□C>

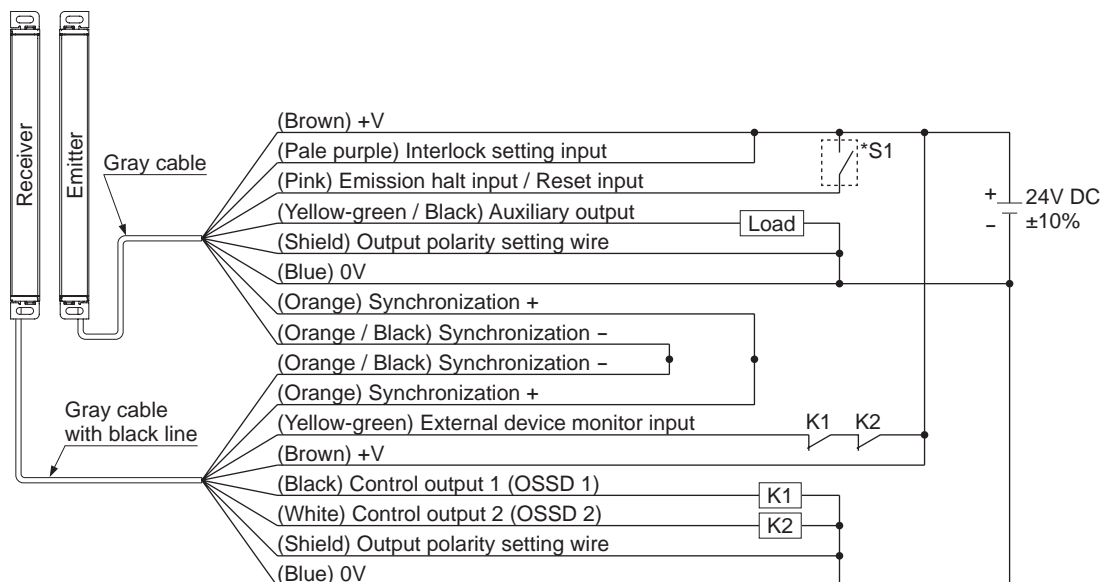

Interlock function	Valid (Manual reset)
External device monitor function	Valid
Auxiliary output	Can be used

The device output is selected depending on the connecting state of the output polarity setting wire (shield). Incorrect wiring may cause the lockout state.

* Symbols

Switch S1

Vs to Vs - 2.5V (sink current 5mA or less): Emission halt (Note 1), Open: Emission

K1, K2: External device (Forced guided relay or magnetic contactor)

Notes: 1) Vs is the applying supply voltage.

2) For resetting, refer to "3-2 Interlock Function."

Wiring

<In case of using I/O circuit for NPN output with SF4B-□C>

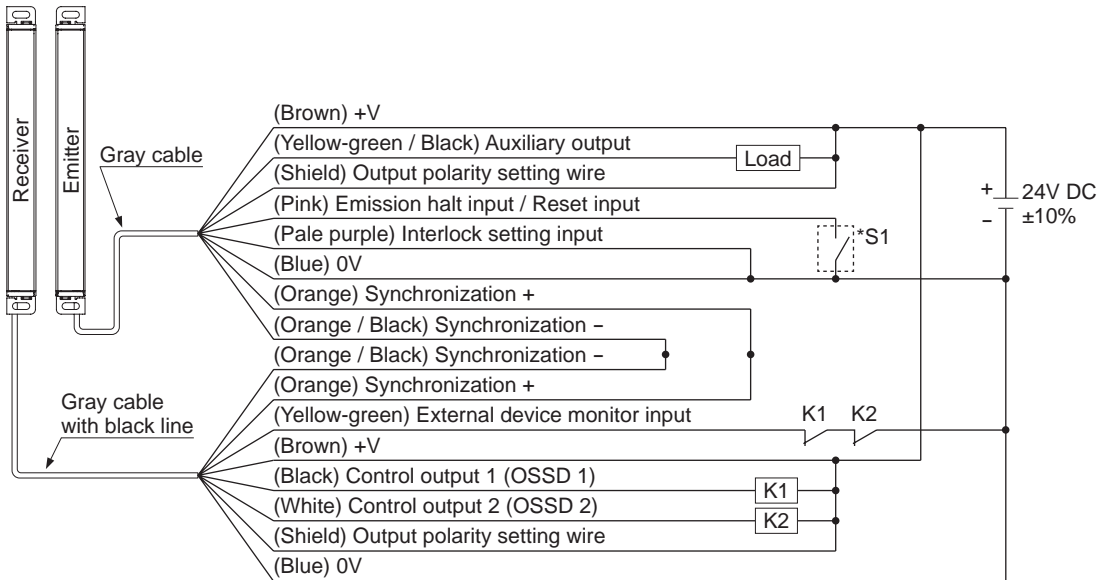

Interlock function	Valid (Manual reset)
External device monitor function	Valid
Auxiliary output	Can be used

The device output is selected depending on the connecting state of the output polarity setting wire (shield). Incorrect wiring may cause the lockout state.

* Symbols

Switch S1	0 to +1.5V (source current 5mA or less): Emission halt, Open: Emission
K1, K2:	External device (Forced guided relay or magnetic contactor)

Note: For resetting, refer to "3-2 Interlock Function."

<In case of using I/O circuit for PNP output with SF4B-□CA-J05>

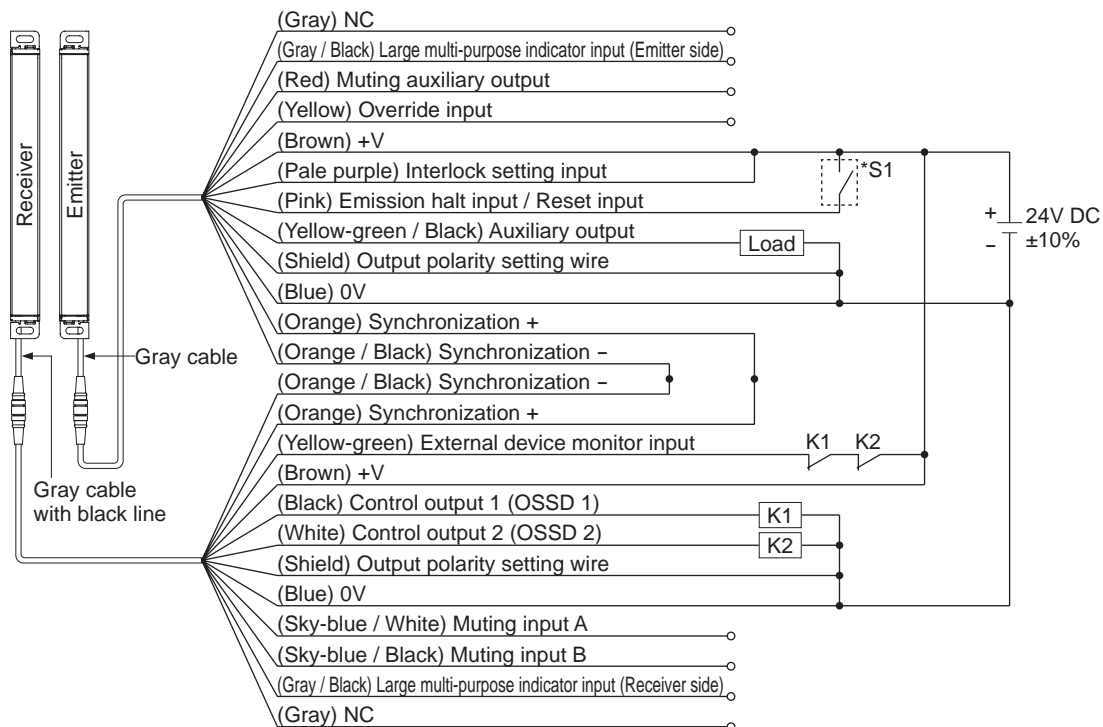

Interlock function	Valid (Manual reset)
External device monitor function	Valid
Auxiliary output	Can be used

The device output is selected depending on the connecting state of the output polarity setting wire (shield). Incorrect wiring may cause the lockout state.

* Symbols

Switch S1
 Vs to Vs - 2.5V (sink current 5mA or less): Emission halt (Note 1), Open: Emission
 K1, K2: External device (Forced guided relay or magnetic contactor)

Notes: 1) Vs is the applying supply voltage.

2) For resetting, refer to "3-2 Interlock Function."

Wiring

<In case of using I/O circuit for NPN output with SF4B-□CA-J05>

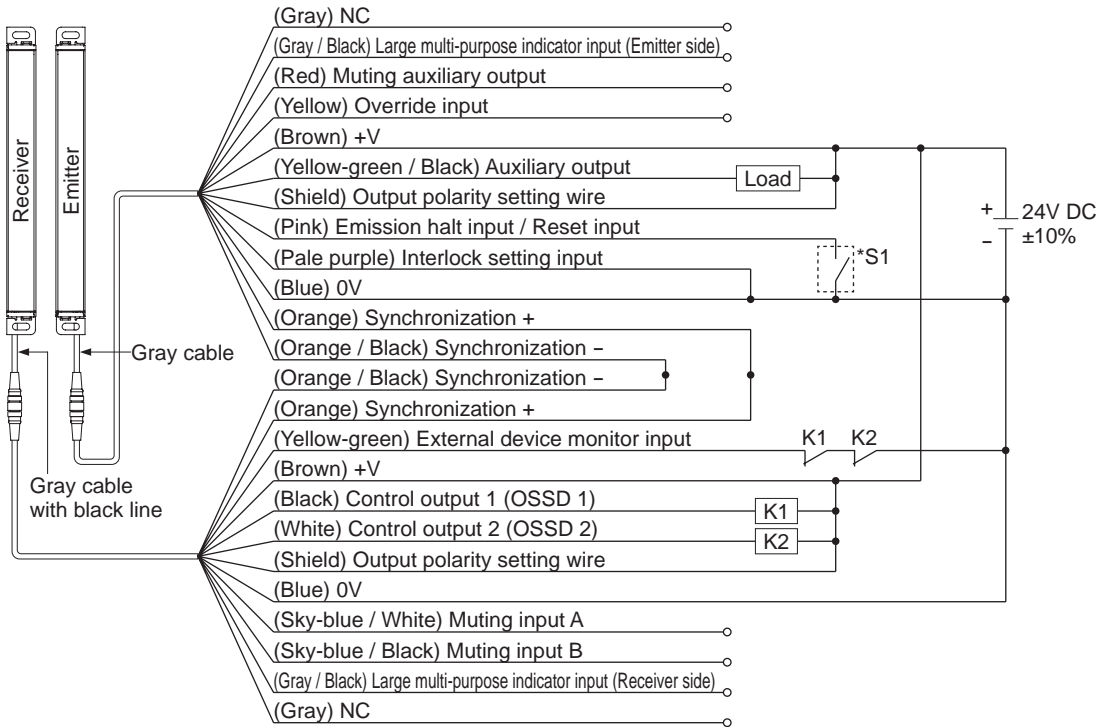

Interlock function	Valid (Manual reset)
External device monitor function	Valid
Auxiliary output	Can be used

The device output is selected depending on the connecting state of the output polarity setting wire (shield). Incorrect wiring may cause the lockout state.

* Symbols

Switch S1
0 to +1.5V (source current 5mA or less): Emission halt, Open: Emission
K1, K2: External device (Forced guided relay or magnetic contactor)

Note: For resetting, refer to "3-2 Interlock Function."

2-5-6 Wiring for Auto-reset (Interlock is Invalid) (Wiring Example of the Control Category 4)

<In case of using I/O circuit for PNP output with SF4B-□C>

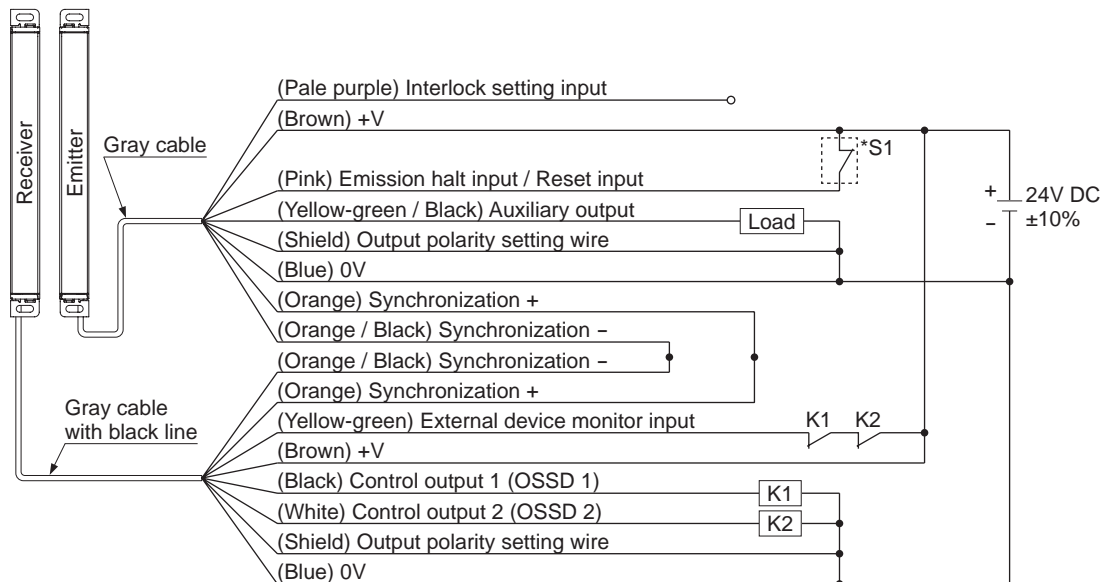

Interlock function	Invalid (Auto-reset)
External device monitor function	Valid
Auxiliary output	Can be used

The device output is selected depending on the connecting state of the output polarity setting wire (shield). Incorrect wiring may cause the lockout state.

* Symbols

Switch S1
 Vs to Vs - 2.5V (sink current 5mA or less): Emission (Note), Open: Emission halt
 K1, K2: External device (Forced guided relay or magnetic contactor)

Notes: 1) Vs is the applying supply voltage.
 2) For resetting, refer to "3-2 Interlock Function."

Wiring

<In case of using I/O circuit for NPN output with SF4B-□C>

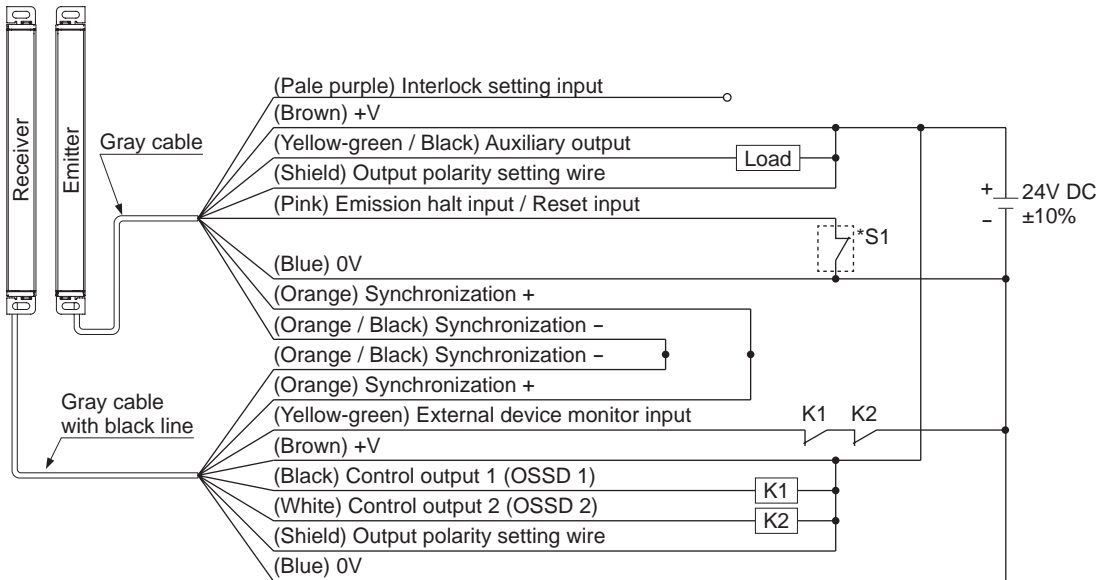

Interlock function	Invalid (Auto-reset)
External device monitor function	Valid
Auxiliary output	Can be used

The device output is selected depending on the connecting state of the output polarity setting wire (shield). Incorrect wiring may cause the lockout state.

* Symbols

Switch S1
0 to +1.5V (source current 5mA or less): Emission, Open: Emission halt
K1, K2: External device (Forced guided relay or magnetic contactor)

Note: For resetting, refer to "3-2 Interlock Function."

<In case of using I/O circuit for PNP output with SF4B-□CA-J05>

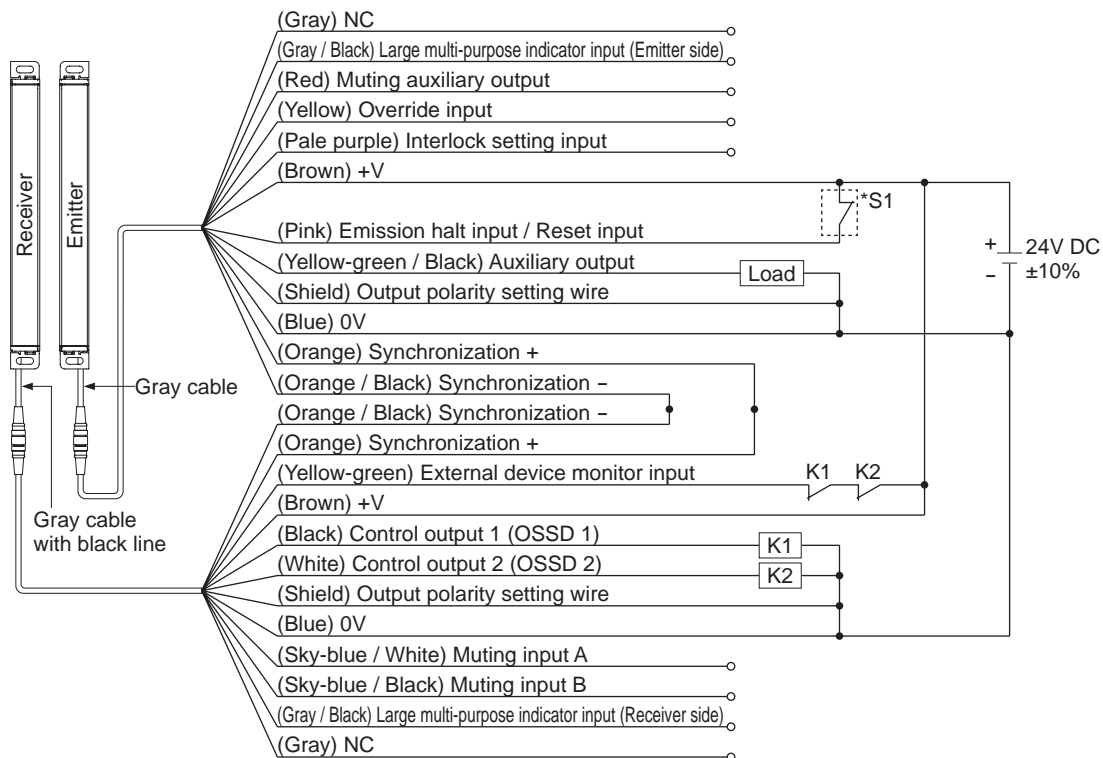

Interlock function	Invalid (Auto-reset)
External device monitor function	Valid
Auxiliary output	Can be used

The device output is selected depending on the connecting state of the output polarity setting wire (shield). Incorrect wiring may cause the lockout state.

* Symbols

Switch S1
 Vs to Vs - 2.5V (sink current 5mA or less): Emission (Note), Open: Emission halt
 K1, K2: External device (Forced guided relay or magnetic contactor)

Notes: 1) Vs is the applying supply voltage.

2) For resetting, refer to "3-2 Interlock Function."

Wiring

<In case of using I/O circuit for NPN output with SF4B-□CA-J05>

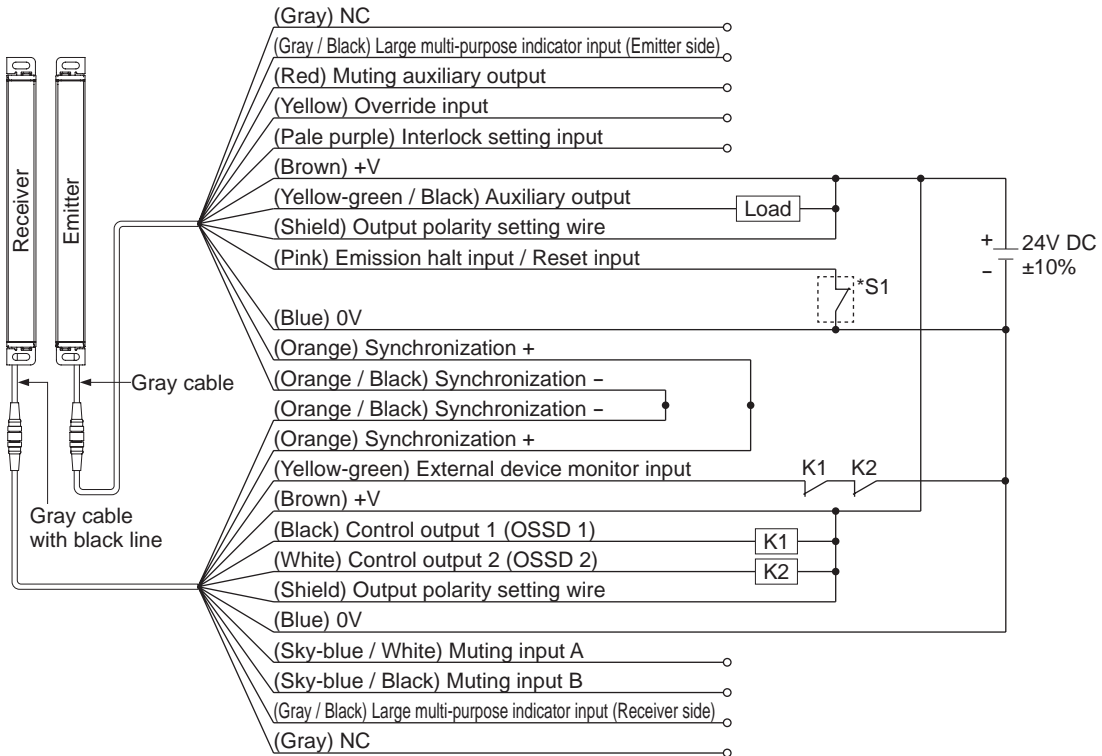

Interlock function	Invalid (Auto-reset)
External device monitor function	Valid
Auxiliary output	Can be used

The device output is selected depending on the connecting state of the output polarity setting wire (shield). Incorrect wiring may cause the lockout state.

* Symbols

Switch S1
0 to +1.5V (source current 5mA or less): Emission, Open: Emission halt
K1, K2: External device (Forced guided relay or magnetic contactor)

Note: For resetting, refer to "3-2 Interlock Function."

2-5-7 Wiring Configuration for Invalid External Device Monitor Function (Wiring Example of the Control Category 4)

This is the configuration for connecting auxiliary output and external device monitor input. At this time, set the auxiliary output with “negative logic of the control output (OSSD 1 / 2)” (factory setting). [Set through the handy controller (SFB-HC) (optional).] The auxiliary output cannot be connected to external devices.

It also enables the external device monitor function to be set at invalid by using the handy controller (SFB-HC) (optional).

<In case of using I/O circuit for PNP output with SF4B-□C>

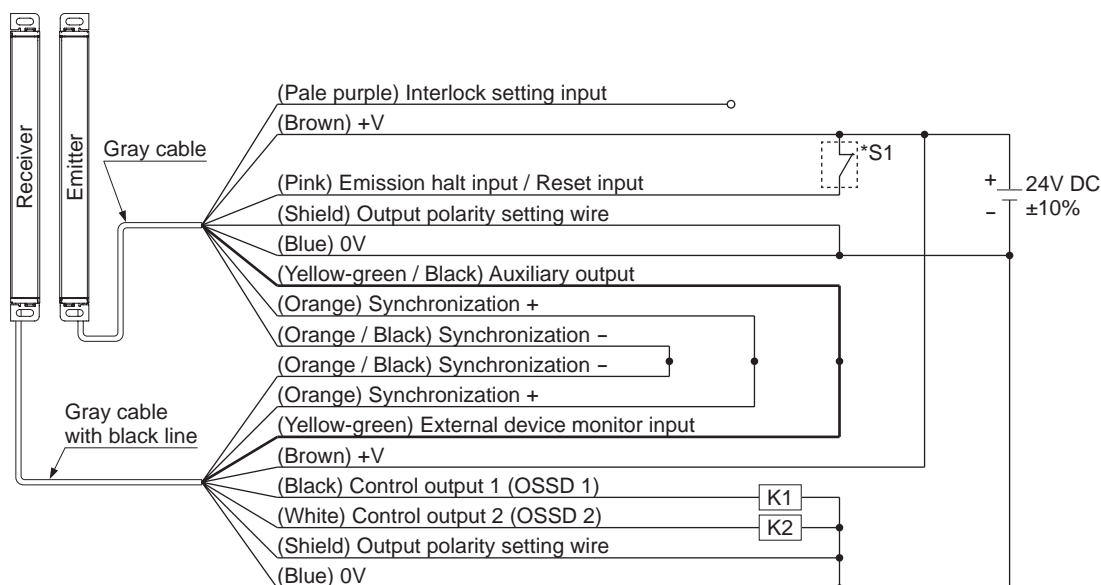

Interlock function	Invalid (Auto-reset)
External device monitor function	Invalid
Auxiliary output	Cannot be used

The device output is selected depending on the connecting state of the output polarity setting wire (shield). Incorrect wiring may cause the lockout state.

* Symbols

Switch S1
 Vs to Vs - 2.5V (sink current 5mA or less): Emission (Note), Open: Emission halt
 K1, K2: Safety relay unit etc.

Note: Vs is the applying supply voltage.

Wiring

<In case of using I/O circuit for NPN output with SF4B-□C>

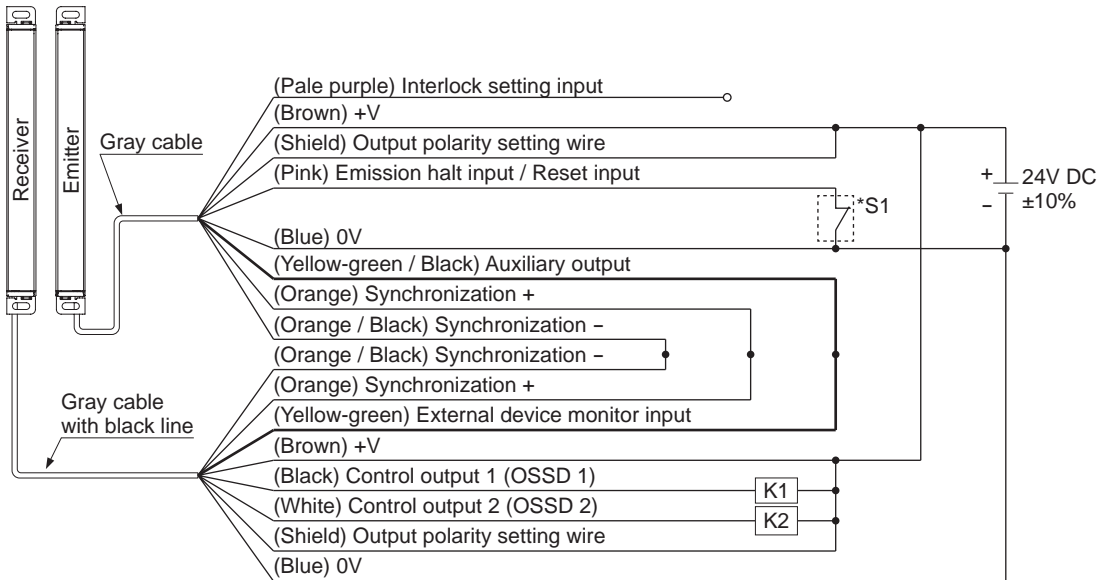

Interlock function	Invalid (Auto-reset)
External device monitor function	Invalid
Auxiliary output	Cannot be used

The device output is selected depending on the connecting state of the output polarity setting wire (shield). Incorrect wiring may cause the lockout state.

* Symbols

Switch S1
 0 to +1.5V (source current 5mA or less): Emission, Open: Emission halt
 K1, K2: Safety relay unit etc.

<In case of using I/O circuit for PNP output with SF4B-□CA-J05>

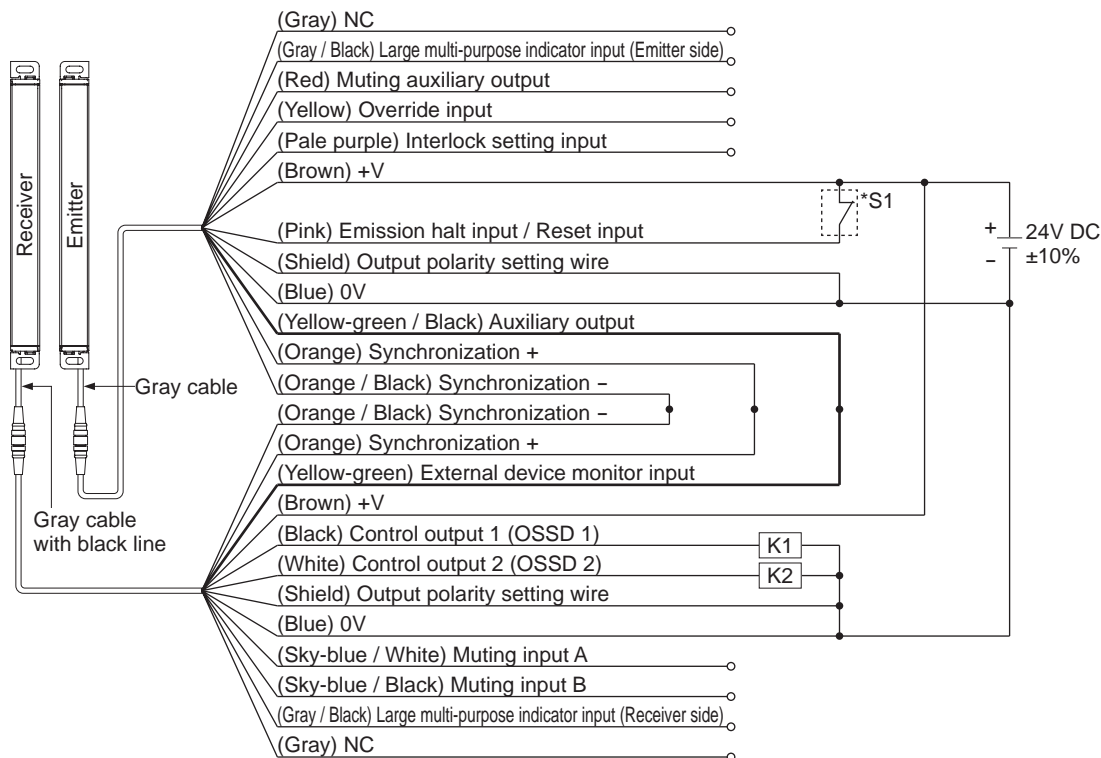

Interlock function	Invalid (Auto-reset)
External device monitor function	Invalid
Auxiliary output	Cannot be used

The device output is selected depending on the connecting state of the output polarity setting wire (shield). Incorrect wiring may cause the lockout state.

* Symbols

Switch S1
 Vs to Vs - 2.5V (sink current 5mA or less): Emission (Note), Open: Emission halt
 K1, K2: Safety relay unit etc.

Note: Vs is the applying supply voltage.

Wiring

<In case of using I/O circuit for NPN output with SF4B-□CA-J05>

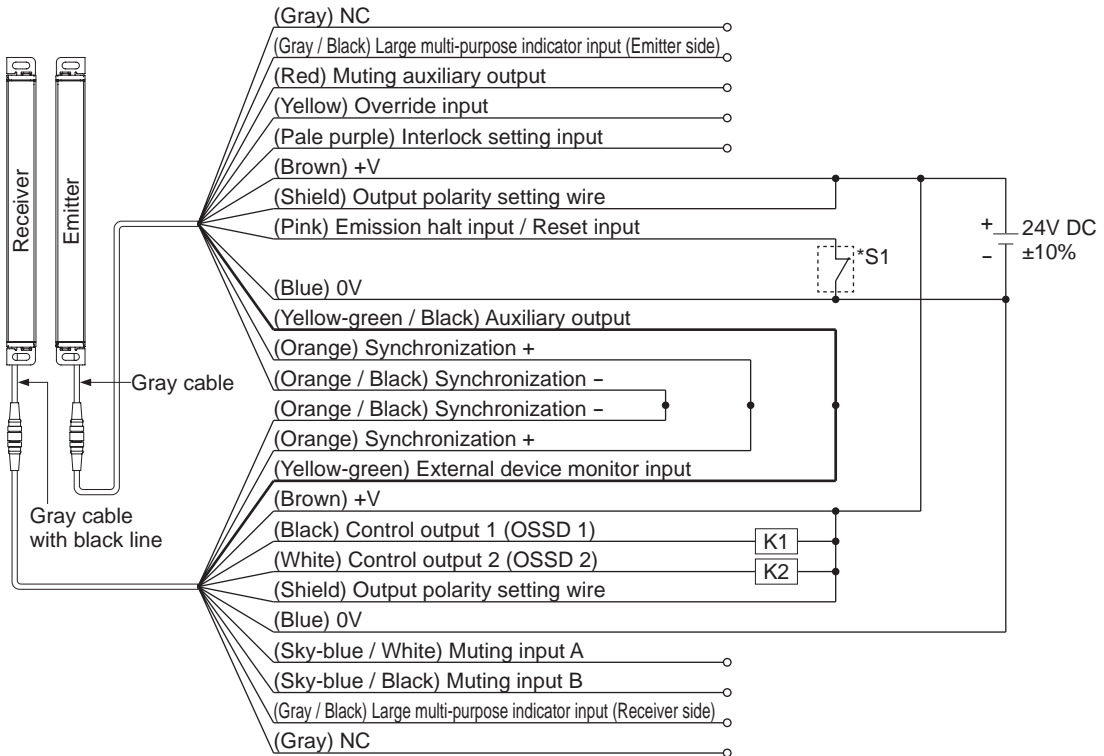

Interlock function	Invalid (Auto-reset)
External device monitor function	Invalid
Auxiliary output	Cannot be used

The device output is selected depending on the connecting state of the output polarity setting wire (shield). Incorrect wiring may cause the lockout state.

* Symbols

Switch S1
0 to +1.5V (source current 5mA or less): Emission, Open: Emission halt
K1, K2: Safety relay unit etc.

2-5-8 Wiring Configuration for Valid Muting Function (For SF4B-□CA-J05 only) (Wiring Example of the Control Category 4)

<In case of using I/O circuit for PNP output with SF4B-□CA-J05>

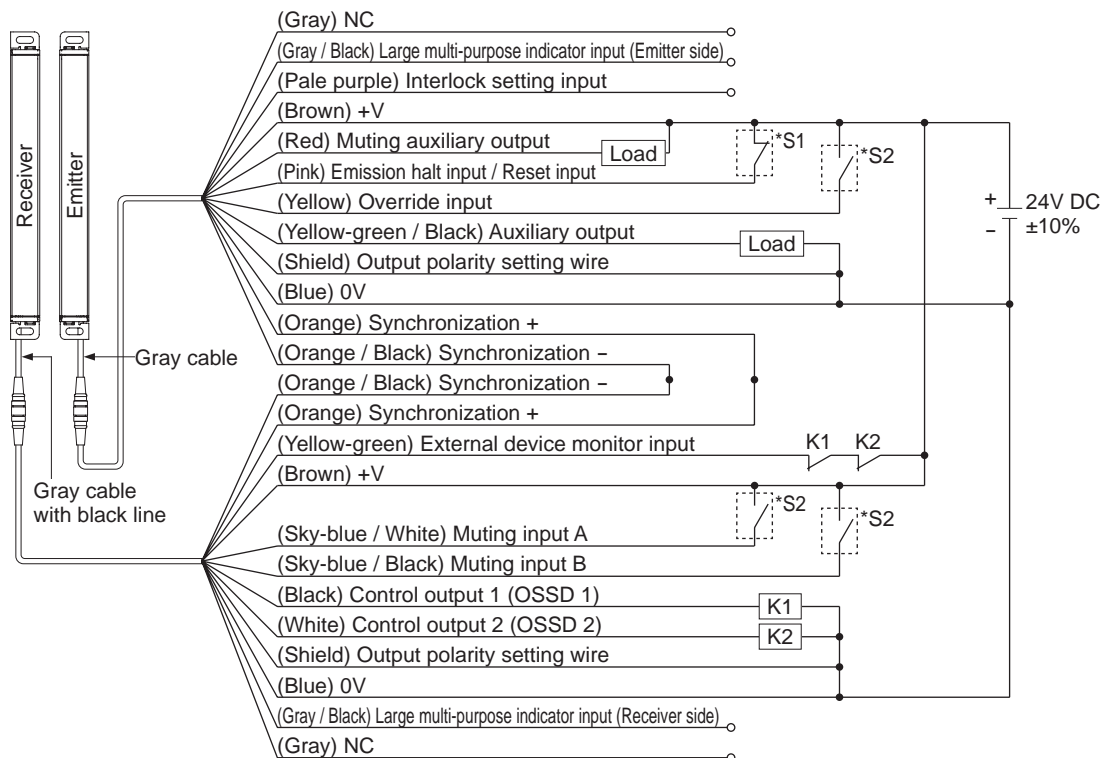

Interlock function	Invalid (Auto-reset)
External device monitor function	Valid
Auxiliary output	Can be used

The device output is selected depending on the connecting state of the output polarity setting wire (shield). Incorrect wiring may cause the lockout state.

* Symbols

Switch S1

- Emission halt input / Reset input

Vs to Vs - 2.5V (sink current 5mA or less): Emission (Note), Open: Emission halt

Switch S2

- Muting input A / B, Override input

Vs to Vs - 2.5V (sink current 5mA or less): Valid (Note), Open: Invalid

K1, K2: External device (Forced guided relay or magnetic contactor)

Note: Vs is the applying supply voltage.

Wiring

<In case of using I/O circuit for NPN output with SF4B-□CA-J05>

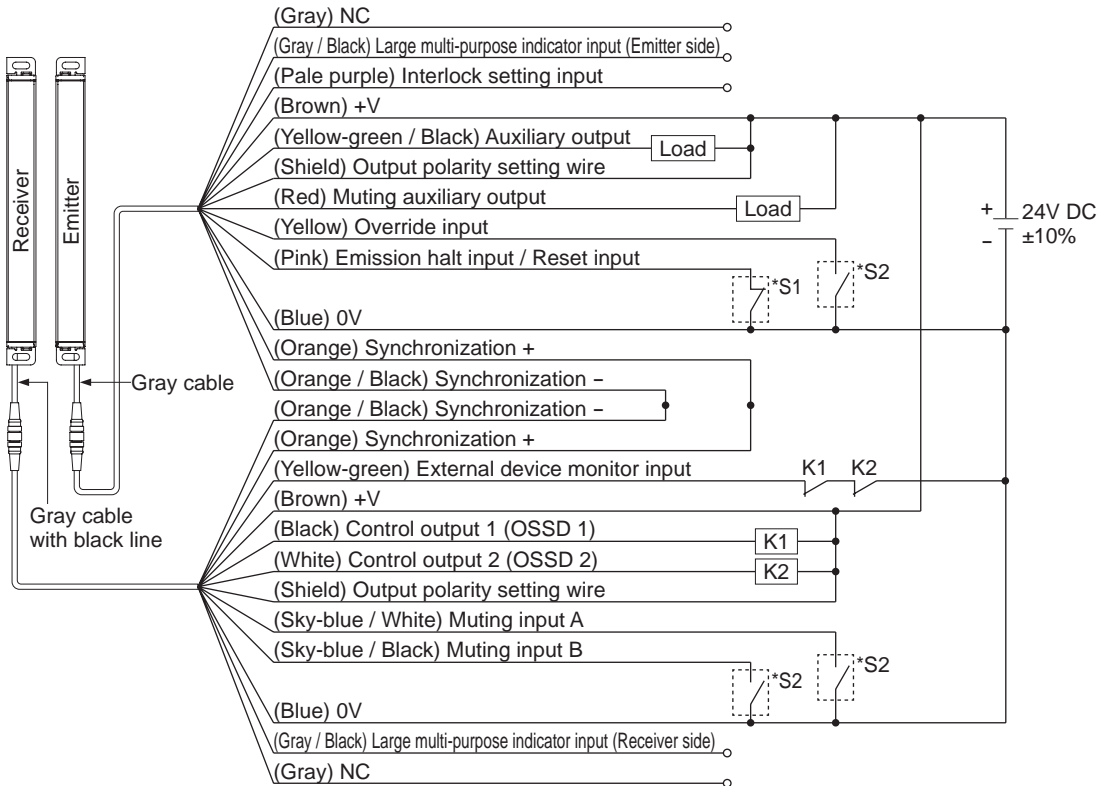

Interlock function	Invalid (Auto-reset)
External device monitor function	Valid
Auxiliary output	Can be used

The device output is selected depending on the connecting state of the output polarity setting wire (shield). Incorrect wiring may cause the lockout state.

* Symbols

Switch S1
● Emission halt input / Reset input
0 to +1.5V (source current 5mA or less): Emission, Open: Emission halt
Switch S2
● Muting input A / B, Override input
0 to + 1.5V (source current: 5mA or less): Valid, Open: Invalid
K1, K2: External device (Forced guided relay or magnetic contactor)

2-6 Adjustment

2-6-1 Beam-axis Alignment

- Step 1 Turn ON the power supply unit of this device.
- Step 2 Check that the fault indicator (yellow) of the emitter and receiver are OFF respectively. If the fault indicator (yellow) lights up or blinks, refer to “**Chapter 5 Troubleshooting**,” and report the symptoms to the maintenance in charge.
- Step 3 In case of using the intermediate supporting bracket **MS-SF4BC-4** or **MS-SF4BC-7**, loosen the one hexagon socket head bolt [M3 (length: 6mm)].
- Step 4 Loosen the four hexagon-socket head bolts [M3 (length: 6mm)] securing the mounting bracket, and rotate the emitter and the receiver to adjust them until the beam-axis alignment indicators light up.
The emitter and the receiver can be fine-adjusted by ± 7 degrees.

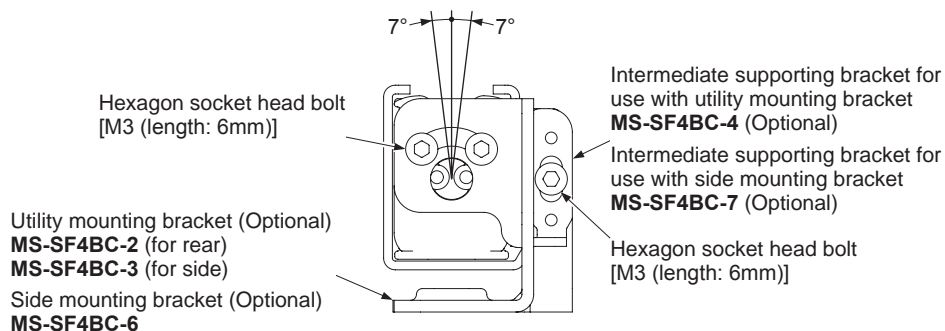

Adjustment

<Reference>

The beam-axis alignment indicator indicates the reception status for each section of the device which is divided into 4 sections.

Also, the A (D) of the beam-axis alignment indicates the light-receiving status of the device top end (bottom end).

For example, when using a 12-beam channel device, there are 3 beam channels per section (i.e., $12/4=3$).

When the top end (bottom end) beam channel is received, the A (D) of the beam-axis alignment indicator blinks in red.

(Example) 12 beam channels

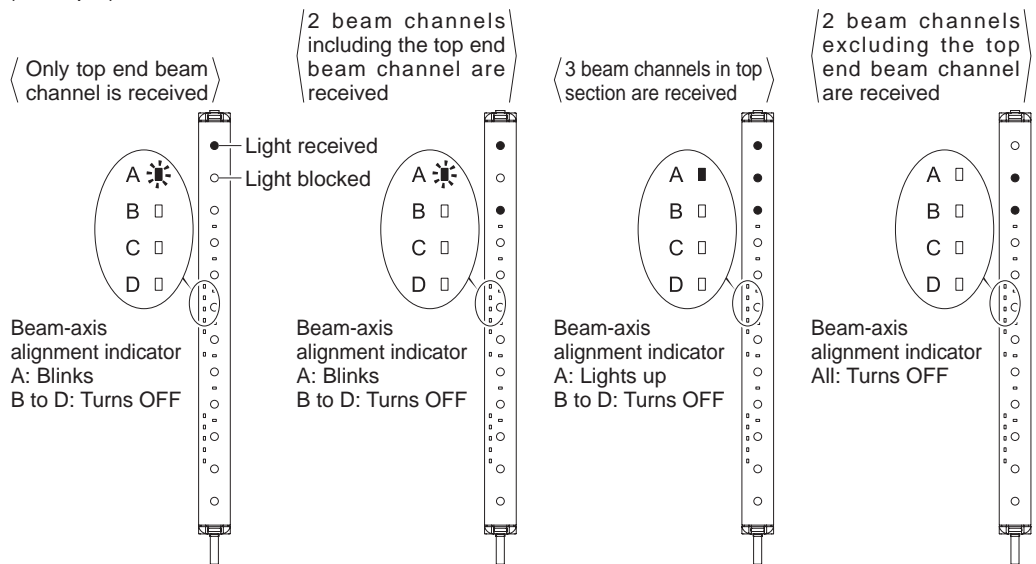

All the 3 beam channels divided into each section are received, the beam-axis alignment indicator lights up in red.

The indicators corresponding to the different sections light up in red, one by one, when the beam channels of the respective sections are received. When all the beam channels are received and the control output (OSSD 1 / 2) turns ON, all the four indicators of the beam-axis alignment indicator turn into green.

Refer to "2-6-3 Operation" for details.

- Step 5 After adjustment, tighten the four hexagon-socket head bolts [M3 (length: 6mm)] to secure the mounting bracket on this device.
The tightening torque should be 0.5N·m or less.
- Step 6 Tighten the one intermediate supporting bracket [M3 (length: 6mm)].
The tightening torque should be 0.5N·m or less.
Verify that the beam-axis alignment indicator and incident light intensity indicator on the display section of the emitter and receiver are green.

⚠ CAUTION

After the beam-axis alignment is finished, make sure to confirm that all the bolts are tightened by the specified torque. For the tightening torque of each bolt, refer to "2-4 Mounting."

2-6-2 Operation Test

- Step 1 Turn ON the power supply unit of this device.
- Step 2 Check that the fault indicator (yellow) of the emitter and receiver are OFF respectively. If the fault indicator (yellow) lights up or blinks, refer to “**Chapter 5 Troubleshooting**,” and report the symptoms to the maintenance in charge.
- Step 3 Move the test rod ($\varnothing 25\text{mm}$ for **SF4B-H□C□**, $\varnothing 45\text{mm}$ for **SF4B-A□C□**) up and down less than 1,600mm/sec. at three positions, just in front of the emitter (A), between the emitter and receiver (B), and just in front of the receiver (C).

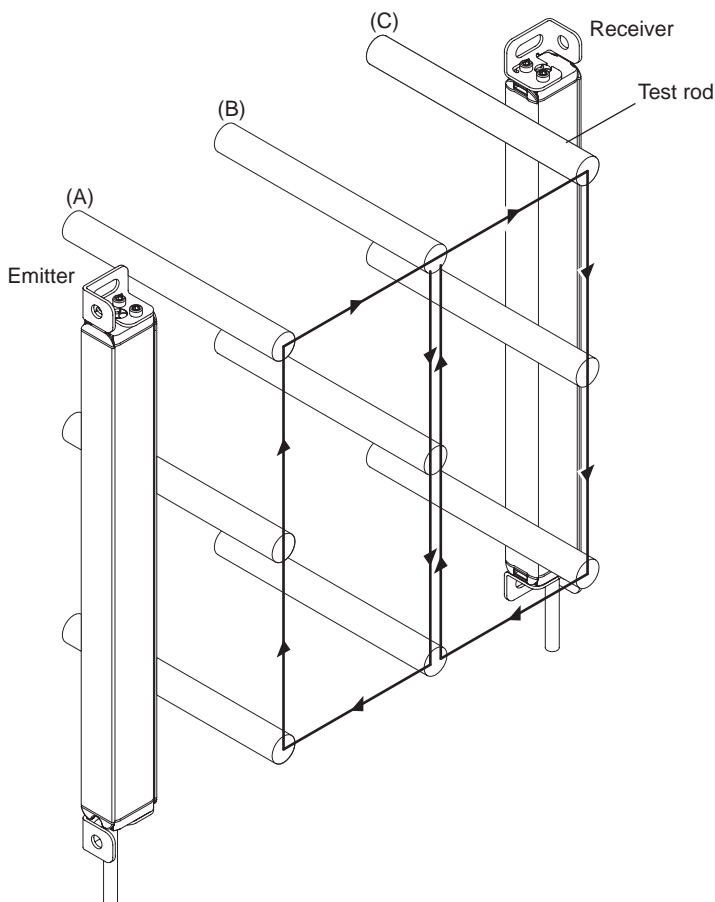

- Step 4 During Step 3 above, check that the control output (OSSD 1 / 2) is in OFF state, and both the OSSD indicator (red) of the receiver and the operation indicator (red) of the emitter light up as long as the test rod is present within the sensing area. If the behavior of the control output (OSSD 1 / 2) and the turning ON / OFF of the emitter / receiver indicators do not correspond to the movement of the test rod, refer to “**Chapter 5 Troubleshooting**,” and report the symptoms to the maintenance in charge.

<Reference>





If the indicators show reception of the light even though the test rod blocks the light, check whether there is any reflective object or extraneous light source near this device or not.

































Adjustment

2-6-3 Operation

1) Normal Operation





The status of the emitter / receiver indicators during normal operation is as described below.









































 Blinks in red,
  Lights up in red,
  Lights up in orange,
  Lights up in green,
  Turns OFF

Device status	Indicators		Control output	
	Emitter	Receiver	OSSD 1	OSSD 2
Light received status (all beams received)	RECEPTION  (Note 1) OSSD  STB  FAULT  (Note 2) PNP  NPN  CTRL  HALT 	RECEPTION  OSSD  STB  FAULT  (Note 2) PNP  NPN  FUNCTION  INTERLOCK 	ON	
Light blocked status One or more lights blocked	RECEPTION  (Note 1) OSSD  STB  FAULT  (Note 2) PNP  NPN  CTRL  HALT 	RECEPTION  OSSD  STB  FAULT  (Note 2) PNP  NPN  FUNCTION  INTERLOCK 	OFF	

Notes: 1) Since the color of the operation indicator changes according to ON / OFF status of the control output (OSSD 1 / 2), the operation indicator is marked as "OSSD" on the device.

2) The status of the emitter / receiver indicators during operation above shows the case in PNP output setting mode. In case of NPN output setting mode, the NPN indicator (orange) lights up.

: Blinks in red,
 : Lights up in red,
 : Lights up in orange,
 : Lights up in green,
 : Turns OFF

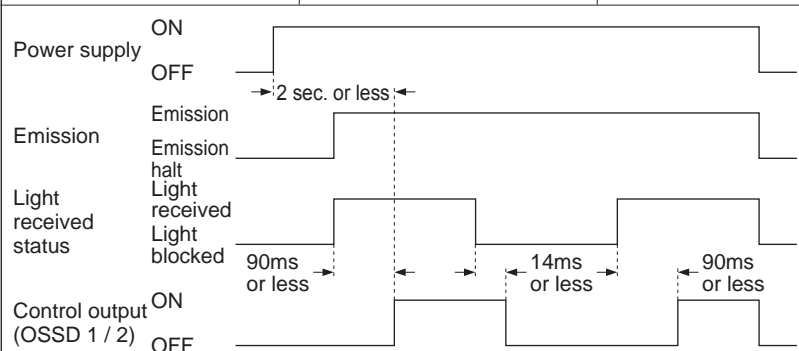
Device status	Indicators		Control output	
	Emitter	Receiver	OSSD 1	OSSD 2
Light blocked status	RECEPTION    (Note 1) OSSD  STB  FAULT  (Note 2) PNP  NPN  CTRL  HALT 	RECEPTION    OSSD  STB  FAULT  (Note 2) PNP  NPN  FUNCTION  INTERLOCK 	OFF	
	RECEPTION    (Note 1) OSSD  STB  FAULT  (Note 2) PNP  NPN  CTRL  HALT 	RECEPTION    OSSD  STB  FAULT  (Note 2) PNP  NPN  FUNCTION  INTERLOCK 	OFF	
Time chart				

- Notes: 1) Since the color of the operation indicator changes according to ON / OFF status of the control output (OSSD 1 / 2), the operation indicator is marked as "OSSD" on the device.
 2) The status of the emitter / receiver indicators during operation above shows the case in PNP output setting mode. In case of NPN output setting mode, the NPN indicator (orange) lights up.

Adjustment





2) When using emission halt function













































This device incorporates the emission halt function. Using this function, it is possible to simulate the light blocked status.

<Reference>





When the emission halt input / reset input is kept open (for manual reset: connected to 0V, +V), the emitter stops emitting light. In this condition, if this device operates properly, the control output (OSSD 1 / 2) of the receiver turns OFF.















































 : Blinks in orange,
  : Lights up in red,
  : Lights up in orange,
  : Lights up in green,
  : Turns OFF

Setting procedure and check items	Indicators		Control output	
	Emitter	Receiver	OSSD 1	OSSD 2
1 Before power is ON, Connect the emission halt input / reset input to Vs. (Note 3)	RECEPTION     (Note 1) OSSD  STB  FAULT  PNP  NPN  CTRL  HALT 	RECEPTION     OSSD  STB  FAULT  PNP  NPN  FUNCTION  INTERLOCK 	OFF	
2 After power is ON, Receiver's control output (OSSD 1 / 2) is ON. (Normal operation)	RECEPTION     (Note 1) OSSD  STB  FAULT  (Note 2) PNP  NPN  CTRL  HALT 	RECEPTION     OSSD  STB  FAULT  (Note 2) PNP  NPN  FUNCTION  INTERLOCK 	ON	

- Notes: 1) Since the color of the operation indicator changes according to ON / OFF status of the control output (OSSD 1 / 2), the operation indicator is marked as "OSSD" on the device.
 2) The status of the emitter / receiver indicators during operation above shows the case in PNP output setting mode. In case of NPN output setting mode, the NPN indicator (orange) lights up.
 3) Vs is the applying supply voltage.

: Blinks in orange, : Lights up in red, : Lights up in orange, : Lights up in green, : Turns OFF

Setting procedure and check items	Indicators		Control output	
	Emitter	Receiver	OSSD 1	OSSD 2
3 Open the emission halt input / reset input. Receiver's control output (OSSD 1 / 2) is OFF. (Emission halt) (Normal operation)	RECEPTION     (Note 1) OSSD  STB  FAULT  (Note 2) PNP  NPN  CTRL  HALT 	RECEPTION     OSSD  STB  FAULT  (Note 2) PNP  NPN  FUNCTION  INTERLOCK 	ON	
4 Connect the emission halt input / reset input to Vs. (Note 3) Receiver's control output (OSSD 1 / 2) is ON. (Normal operation)	RECEPTION     (Note 1) OSSD  STB  FAULT  (Note 2) PNP  NPN  CTRL  HALT 	RECEPTION     OSSD  STB  FAULT  (Note 2) PNP  NPN  FUNCTION  INTERLOCK 	ON	

- Notes: 1) Since the color of the operation indicator changes according to ON / OFF status of the control output (OSSD 1 / 2), the operation indicator is marked as "OSSD" on the device.
 2) The status of the emitter / receiver indicators during operation above shows the case in PNP output setting mode. In case of NPN output setting mode, the NPN indicator (orange) lights up.
 3) Vs is the applying supply voltage.

Adjustment

3) When an error occurs

If a device error is detected, the device will turn the control output (OSSD 1 / 2) OFF. Then the fault indicators (yellow) on the emitter and receiver light up or blink.

- If an emitter error is detected, the emitter will be locked out, stopping its emission, and the control output (OSSD 1 / 2) will be turned OFF.
- If a receiver error is detected, the receiver will be locked out, and the control output (OSSD 1 / 2) will go into OFF state.

: Blinks in yellow, : Lights up in red, : Lights up in orange, : Turns OFF

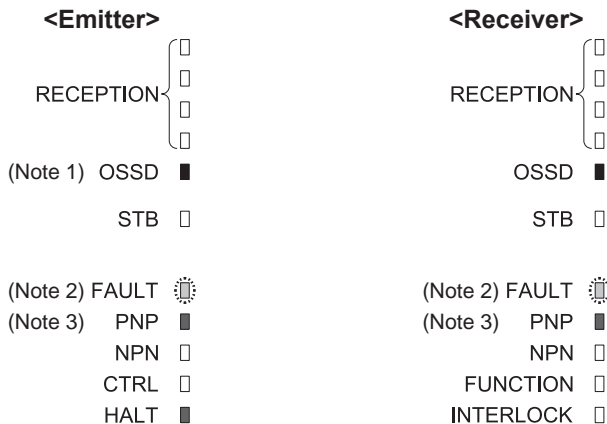

Notes: 1) Since the color of the operation indicator changes according to ON / OFF status of the control output (OSSD 1 / 2), the operation indicator is marked as "OSSD" on the device.

2) Refer to "Chapter 5 Troubleshooting" for the number of blinking times of the fault indicators.

3) The status of the emitter / receiver indicators during operation above shows the case in PNP output setting mode. In case of NPN output setting mode, the NPN indicator (orange) lights up.

Since this device will not return to normal operation automatically after the removal of the source of error, it is necessary to turn the power OFF and ON again.

(Source of error): The control output (OSSD) short-circuit, extraneous light detection, sensor failure, etc.

Refer to "Chapter 5 Troubleshooting" and remove the source of error.

3-1 Self-diagnosis Function

This device incorporates the self-diagnosis function. The self-diagnosis is carried out when the power is turned ON and while the operation periodically. In case an abnormality is detected during self-diagnosis, the device is put in the lockout state at that instant, and the control output (OSSD 1 / 2) is fixed at the OFF state. Refer to “**Chapter 5 Troubleshooting**” and remove the source of error.

3-2 Interlock Function

The selection of manual reset / auto reset is available by applying the Interlock setting input wiring.

The interlock becomes available by selecting manual reset.

Interlock setting input wire (pale purple)	Setting for interlock function
In case of selecting PNP output: connect to +V In case of selecting NPN output: connect to 0V	Manual reset
Open	Auto reset

WARNING

- In case of using the interlock function, be sure there exists no operator inside of the dangerous area. It causes death or serious injury without the confirmation.
- The reset switch shall be placed in area where all over the dangerous zone shall be comprehend and out side of the dangerous zone.
- If this device is used with the auto-reset, avoid an auto-restart after the safety output stop of the system by using a safety relay unit, etc. (EN 60204-1)

Manual reset: The control output (OSSD 1 / 2) is not turned ON automatically even though this device is received the light. When this device is reset in light received state [open the emission halt input / reset input → short-circuit the device to 0V or +V → open], the control output (OSSD 1 / 2) is turned ON.

<Timing chart>

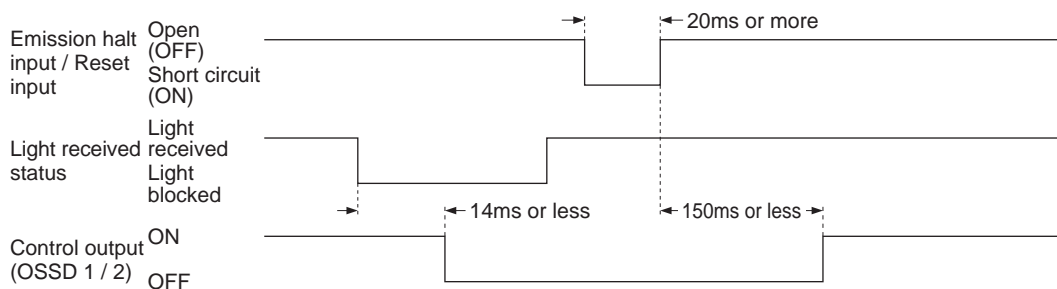

Auto reset: The control output (OSSD 1 / 2) is turned ON automatically when this device receives the light.

<Reference>

It is possible to change the conditions for interlocking by using the handy controller (**SFB-HC**) (optional).

Function

3-3 Emission Halt Function

This function stops the emission process of the emitter. With the emission halt input / reset input line state, it enables to select either emission or emission halt.

Setting for interlock function	Emission halt input / Reset input wire (pink)	Emission halt input	Control output (OSSD 1 / 2) status
Manual reset	Open	Invalid	ON
	When selecting PNP output: connect to +V When selecting NPN output: connect to 0V	Valid	OFF
Auto reset	Open	Valid	OFF
	When selecting PNP output: connect to +V When selecting NPN output: connect to 0V	Invalid	ON

During emission halt, the control output (OSSD 1 / 2) becomes OFF state. By using this function, malfunction due to extraneous noise or abnormality in the control output (OSSD 1 / 2) and the auxiliary output can be determined even from the equipment side. Normal operation is restored when the emission halt input / reset input is connected to 0V or +V (for manual reset: open).

<Timing chart>

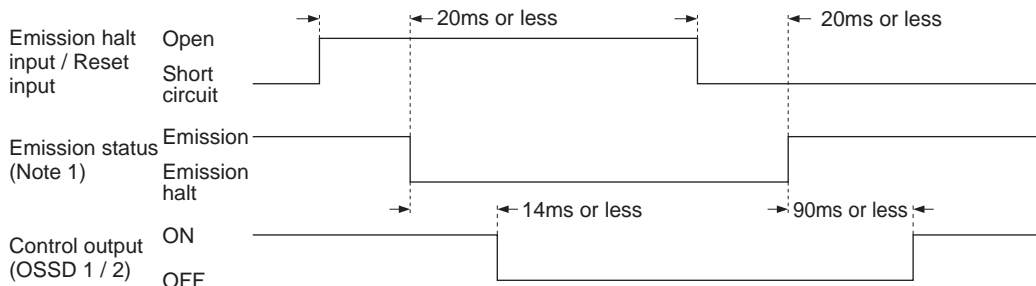

⚠ WARNING

Do not use the emission halt function for the purpose of stopping the machine in which the **SF4B-C** is installed. Failure to do so could result in death or serious injury.

3-4 Auxiliary Output (Non-safety Output)

This device incorporates the auxiliary output for the non-safety output. The auxiliary output is incorporated in the emitter.

Auxiliary output setting	Normal operation			Lockout
	Emission halt input	Control output (OSSD 1 / 2) status		
		Light received	Light blocked	
Negative logic of OSSD	ON	OFF	ON	ON

<Timing chart>

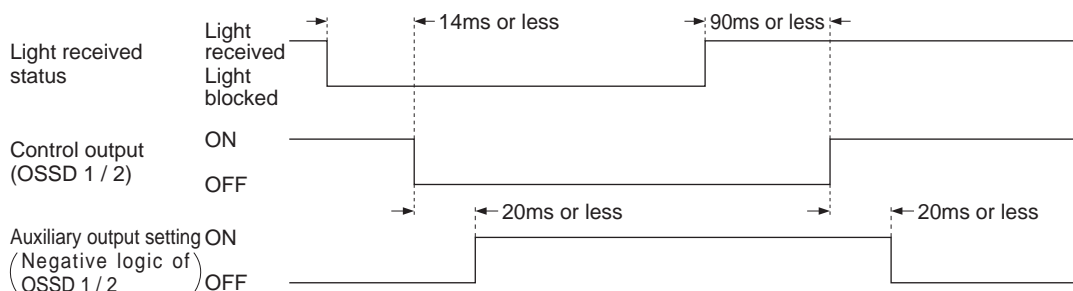

⚠ WARNING

Do not use the auxiliary output for the purpose of stopping the machine in which the **SF4B-□C□** series is installed. Failure to do so could result in death or serious injury.

<Reference>

It is possible to switch the output operation for auxiliary output by using the handy controller (**SFB-HC**) (optional).

3-5 External Device Monitor Function

This is the function for checking whether the external safety relay connected to the control output (OSSD 1 / 2) performs normally in accordance with the control output (OSSD 1 / 2) or not. Monitor the contacting point "b" of the external safety relay, and if any abnormality such as deposit of the contacting point, etc. is detected, change the status of the device into lockout one, and turn OFF the control output (OSSD 1 / 2).

- When the external device monitor function is set to be valid:**
 Connect the external device monitor input wire (yellow-green) to the external safety relay which is connected to the control output 1 (OSSD 1) wire (black) and the control output 2 (OSSD 2) wire (white).
- When the external device monitor function is set to be invalid:**
 Connect the external device monitor input wire (yellow-green) to the auxiliary output wire (yellow-green / black). At this time, the auxiliary output is set as [negative logic of control in case the external device monitor input function is invalid, output (OSSD 1 / 2)] (factory setting) [Set through the handy controller (**SFB-HC**) (optional)].
 The auxiliary output cannot be connected to external devices.

<Reference>

It is also possible to set the external device monitor function into 'invalid' by using the handy controller (**SFB-HC**) (optional).

Function

<Timing chart (Normal)>

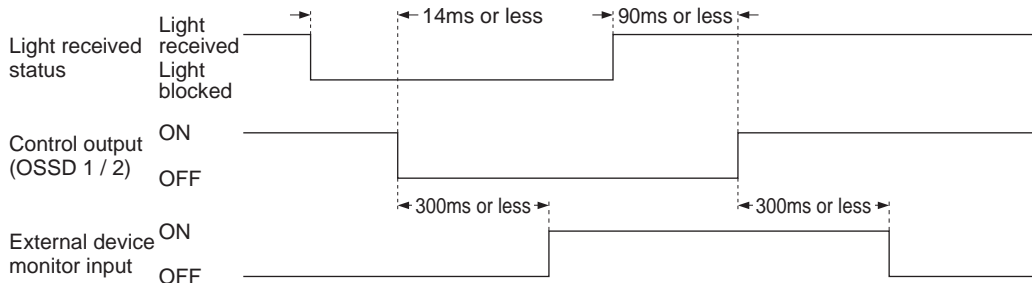

The setting time of the device monitor is 300ms or less. Exceeding 300ms turns the device into lockout status. It can be set within 100 to 600ms (unit: 10ms) by using the handy controller (SFB-HC) (optional).

<Timing chart (Error 1)>

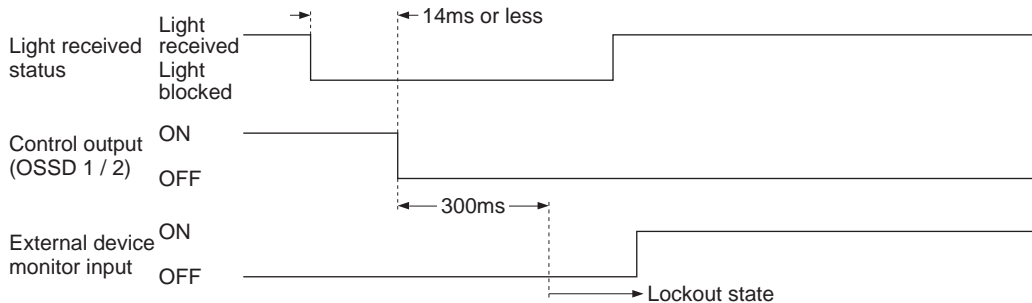

<Timing chart (Error 2)>

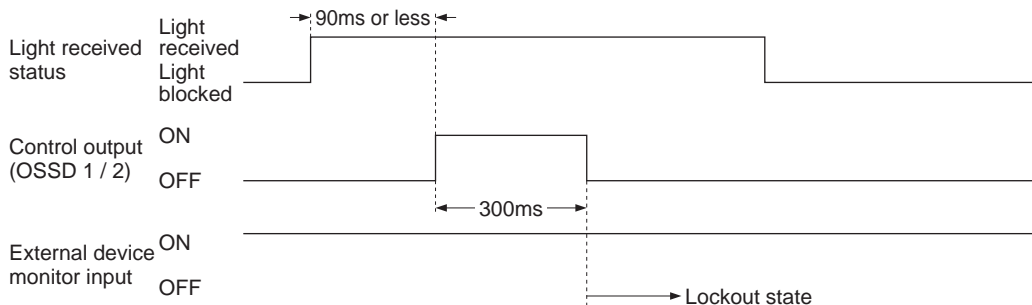

3-6 Muting Function (For SF4B-□CA-J05 only)

WARNING

- Incorrect using of the muting control may cause any accident. Please understand the muting control fully, and use it. As for the muting control, the following international standards define the requirements.
ISO 13849-1 (EN ISO 13849-1 / JIS B 9705-1):
“Safety of machinery - Safety-related parts of control systems - Part 1: General principles for design, Article 5.2.5 Muting”
IEC 61496-1 (ANSI/UL 61496, JIS B 9704-1):
“Safety of machinery - Electro sensitive protective equipment - Part 1: General requirements and tests, Annex A, A.7 Muting”
IEC 60204-1 (JIS B 9960-1):
“Safety of machinery - Electrical equipment of machines - Part 1: General requirements, 9.2.4 Overriding safeguards”
EN 415-4:
“Safety of packaging machines - Part 4: Palletizers and depalletizers, Annex A, A2.2 Muting”
ANSI B11.19-1990:
“for Machine Tools-Safeguarding When Referenced by the Other B11 Machine Tool Safety Standards-Performance Criteria for the Design, Construction, Care, and Operation” 4.2.3 Presence-Sensing Devices: Electro-Optical and Radio Frequency (R.F.)
ANSI/RIA R15.06-1999:
“For Industrial Robots and Robot Systems - Safety Requirements, 10.4.5 Muting”
- Use the muting control while the machine cycle is not in danger mode. Maintain safety with the other measure while the muting control is activated.
- For the application that the muting control is activated when a workpiece passes through the sensor, place the muting sensor so that the conditions for the muting control cannot be satisfied by intrusion of personnel when the workpiece is passing through the sensor or the workpiece is not passing through it.
- Implement a risk assessment, and if a muting indicator is required, use it after checking the standards and regulations in the country or region where the device is to be used.
- Be sure to check the operation of the muting function before its use.

This function turns the safety function into invalid temporarily. When the control output (OSSD 1 / 2) is ON, this function is available for passing the workpiece through the sensing area of the device without stopping the device.

The muting function becomes valid when all the conditions listed below are satisfied:

- The control output (OSSD 1 / 2) shall be ON.
- Muting input A and B shall be changed from OFF (open) to ON. At this time, the time difference occurred by changing the muting input A and B into ON status shall be 0.03 to 3 sec. (Note 1)

The following devices, photoelectric sensor with semiconductor output, inductive proximity sensor, position switch on NO (Normally Open) contacting point, etc. are available for applying to the muting sensor.

Notes: 1) 0 to 3 sec. is allowable by using the handy controller Ver. 2.1 (**SFB-HC**) (optional) and connecting NO (Normally Open) type muting sensor to the input A, as well as connecting NC (Normally Closed) type muting sensor to the input B.

- 2) The muting indicator diagnosis function can be set with the handy controller Ver. 2 or later (**SFB-HC**) (optional), but it must be set to invalid. If the muting indicator diagnosis function is set to valid, the muting function cannot be used.

Function

<Output operation of muting sensors>

	Operation at ON state	Operation at OFF state
NO (Normally Open) type ON with light non-received status (photoelectric sensor, etc.) ON with object approaching status (inductive proximity sensor, etc.) ON with object contacted status (position switch, etc.)	Output 0V or +V	Open

⚠ WARNING

Be sure to use a muting sensor that satisfies the <Output operation of muting sensors> above. If the other muting sensor not satisfying the specification above, the muting function might become valid with the timing that the machine designer cannot expect and could result in death or serious injury.

<Installation condition example of muting sensors>

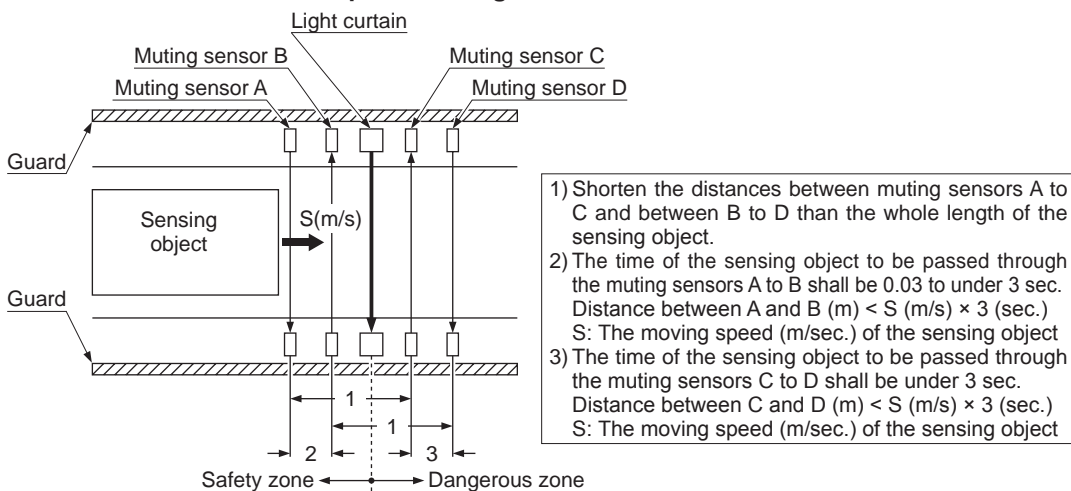

<For PNP output>

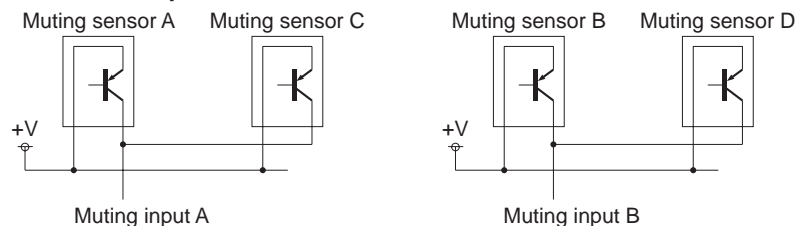

<For NPN output>

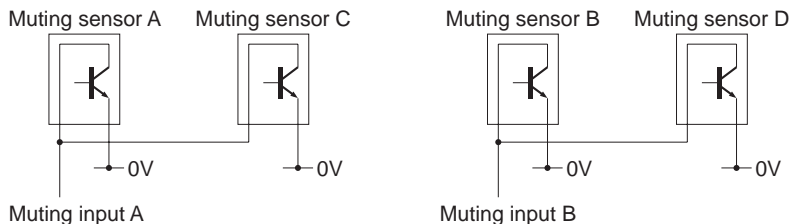

<Timing chart>

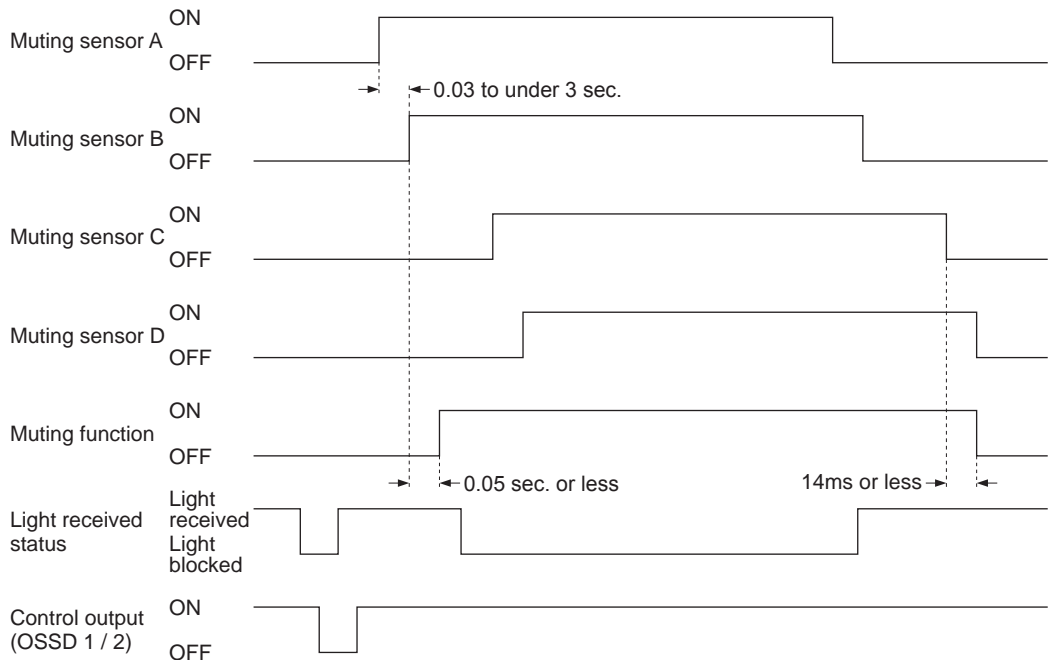

<Reference>

It is possible to set the muting function into invalid per beam channel respectively and to specify the input order of the muting input A and B to be set into valid by using the handy controller (SFB-HC) (optional).

<Auxiliary muting output wiring>

To trigger a large multi-purpose indicator during muting operation, connect the wiring as follows: As for lead wires other than below, perform wiring depending on your application. For details, refer to "2-5 Wiring."

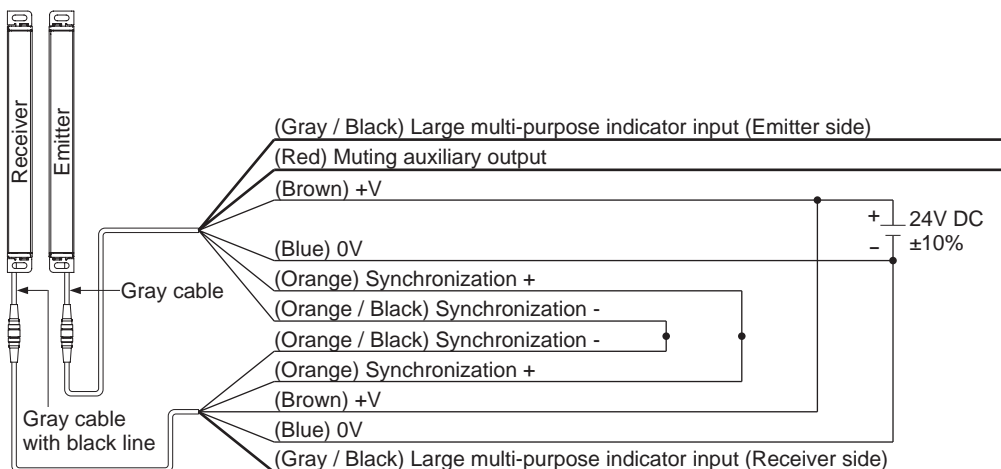

3-7 Override Function (For SF4B-□CA-J05 only)

WARNING

- Incorrect using of the muting control may cause any accident. Please understand the muting control fully, and use it. As for the muting control, the following international standards define the requirements.
ISO 13849-1 (EN ISO 13849-1 / JIS B 9705-1):
“Safety of machinery - Safety-related parts of control systems - Part 1: General principles for design, Article 5.2.5 Muting”
IEC 61496-1 (ANSI/UL 61496, JIS B 9704-1):
“Safety of machinery - Electro sensitive protective equipment - Part 1: General requirements and tests, Annex A, A.7 Muting”
IEC 60204-1 (JIS B 9960-1):
“Safety of machinery - Electrical equipment of machines - Part 1: General requirements, 9.2.4 Overriding safeguards”
EN 415-4:
“Safety of packaging machines - Part 4: Palletizers and depalletizers, Annex A, A2.2 Muting”
ANSI B11.19-1990:
“for Machine Tools-Safeguarding When Referenced by the Other B11 Machine Tool Safety Standards-Performance Criteria for the Design, Construction, Care, and Operation” 4.2.3 Presence-Sensing Devices: Electro-Optical and Radio Frequency (R.F.)
ANSI/RIA R15.06-1999:
“For Industrial Robots and Robot Systems - Safety Requirements, 10.4.5 Muting”
- Use the muting control while the machine cycle is not in danger mode. Maintain safety with the other measure while the muting control is activated.
- For the application that the muting control is activated when a workpiece passes through the sensor, place the muting sensor so that the conditions for the muting control cannot be satisfied by intrusion of personnel when the workpiece is passing through the sensor or the workpiece is not passing through it.
- Implement a risk assessment, and if a muting indicator is required, use it after checking the standards and regulations in the country or region where the device is to be used.
- Be sure to check the operation of the muting function before its use.
- Make sure manually to operate system for starting override function. Furthermore, the system shall be placed in area where all over the dangerous zone shall be comprehend and outside of the dangerous zone.
- Using override function, make sure that there exist no operator in the dangerous zone, which may result in death or serious injury.

The override function forcibly turns the safety function into invalid. This function is used for the following cases: when the customer who uses the muting function needs to start the device with the control output (OSSD 1 / 2) be OFF status, when the device is required to continue operating even though the muting sensor becomes valid after the muting sensor is turned ON at the starting of line.

The override function becomes valid when all the conditions listed below are satisfied:

- The signal shall be input to either muting input A or B, or to both of the inputs.
- The override input shall be short-circuited to 0V or +V, and the emission halt input / reset input shall be opened. (3 sec. continuously)

If one of the two conditions above becomes invalid or timing exceeds 60 sec. (Note 1), the override function becomes invalid.

Notes: 1) By using the handy controller Ver. 2.1 (**SFB-HC**) (optional), the timing can be changed in the range of 60 to 600 sec. in units of 10 sec.

2) The muting indicator diagnosis function can be set with the handy controller Ver. 2.1 (**SFB-HC**) (optional), but it must be set to invalid. If the muting indicator diagnosis function is set to valid, the muting function cannot be used.

3) The override function operates only when the auto-reset is ON (the interlock is invalid).

<Timing chart>

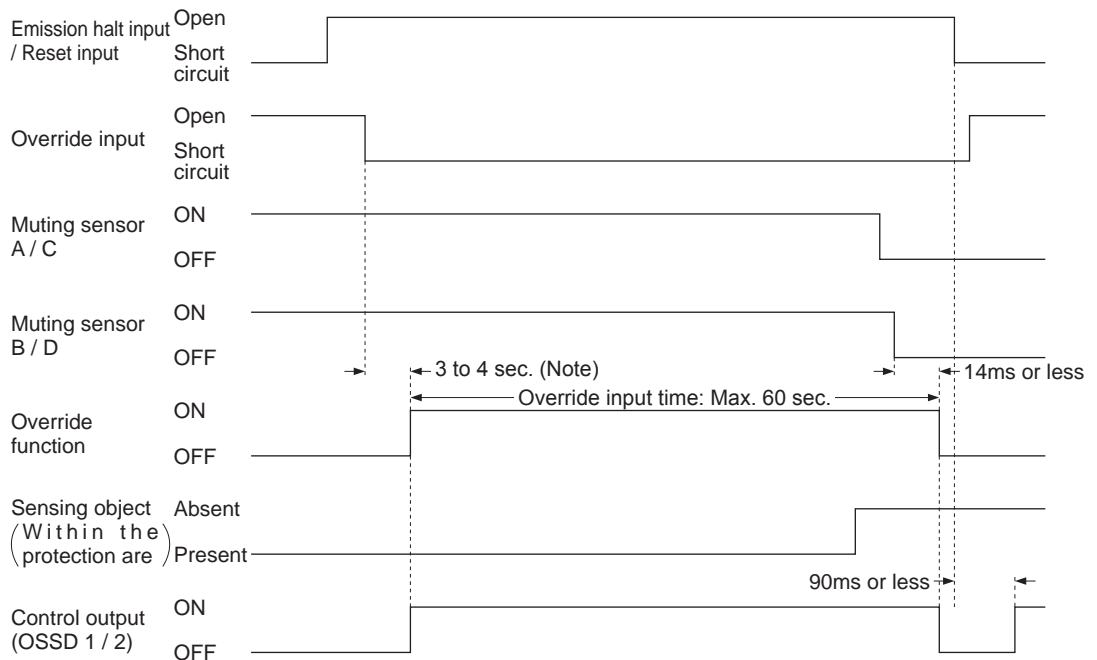

Note: This is when the muting indicator diagnosis function is valid. If the muting indicator does not light up even if 1 sec. is passed, the override function becomes invalid. When the muting indicator diagnosis function is invalid, the muting function becomes valid 3 sec. after the input conditions of the muting sensor A (C) and B (D) were satisfied.

Function

3-8 Functions Using Handy Controller (SFB-HC) (Optional)

This device enables to set each function using the handy controller (**SFB-HC**) (optional). The settable functions and the factory setting of each function are as follows.
For details, refer to the instruction manual enclosed with the handy controller.

WARNING

Among the functions, the contents related to the safety distance such as the size of the minimum sensing object are varied depending on the setting condition. When setting each function, recalculate the safety distance, and make enough space larger than the calculated safety distance. Failure to do so might cause the accident that the device cannot stop quickly before reaching the dangerous area of the device, resulting in the death or serious injury.

- **Fixed blanking function**

This function enables to protect the control output (OSSD 1 / 2) from turning into OFF even though the specific beam channel is blocked.
The factory setting is set to be invalid for the fixed blanking function.

- **Floating blanking function**

This function enables to protect the control output (OSSD 1 / 2) from turning into OFF even though the number of the blocked beam channels are lower than that of the setting beam channels. 1, 2 or 3 beam channels are settable as the blocking beam channels.
The factory setting is set to be invalid for the floating blanking function.

Both fixed blanking function and floating blanking function are settable simultaneously.

- **Emission amount control function**

The two modes, normal mode and short mode, can be set / changed by controlling the emission amount. The factory setting is set to the normal mode for the emission amount control function.

- **Auxiliary output switching function (non-safety output)**

The following outputs are switchable as the auxiliary output.

0. Negative logic of the control output (OSSD 1 / 2) (factory setting)
1. Positive logic of the control output (OSSD 1 / 2)
2. For emission: output ON, For non-emission: output OFF
3. For emission: output OFF, For non-emission: output ON
4. For unstable incident light: OFF (Note 1)
5. For unstable incident light: ON (Note 1)
6. For muting: ON
7. For muting: OFF
8. For light reception: ON, For light blocked: OFF (Note 2)
9. For light reception: OFF, For light blocked: ON (Note 2)

Notes: 1) The output cannot be used while the fixed blanking function, floating blanking function or the muting function is activated.

- 2) This device outputs the light received / blocked state under activating the auxiliary output switching function using the handy controller irrespective of activating other functions: fixed blanking function, floating blanking function and muting function.

<e.g.>

In case of activating the fixed blanking function, the control output (OSSD 1 / 2) becomes ON with the shielded object existed in the setting range and other ranges are in light receiving status. If the auxiliary output switching function activates in No. 8 output, this device becomes OFF because the sensor itself detects the object.

- **Interlock setting changing function**

It is selectable one interlock state among the following three interlock settings.

- **Start / Restart interlock**

The device goes into the interlock state after the power is turned ON, or when the light is blocked.

The factory setting is start / restart interlock.

- **Start interlock**

The device goes into the interlock state when the power supply is turned ON. Once this interlock is reset, the device does not go into the interlock state.

- **Restart interlock**

The device does not go into the interlock state when turning ON the power supply. Only when the control output (OSSD 1 / 2) becomes ON and the light is blocked after the power is turned ON and this device receives the light, the device goes into the interlock state.

- **External device monitor setting changing function**

The setting of the external device monitor is changeable.

1. Allowable time for response time: 100 to 600ms (Unit: 10ms)

Factory setting is 300ms.

2. The external device monitor function can be selected to valid or invalid.

The factory setting is set to valid for the external device monitor function.

- **Muting setting changing function (For SF4B-□CA-J05 only)**

The setting of the muting function is changeable.

1. Input order of the muting input A and B can be specified so that the muting function will be valid.

The muting function will be valid either the muting input A or B comes first to input at the time of factory setting.

2. Select either to validate or invalidate the muting function per beam channel. (Note 1)

The muting function is valid in all beam channels at the time of factory setting.

3. Invalidate the muting indicator diagnosis function when using the muting function. (Note 2, 3)

4. Output operation of a muting sensor which is to be connected to the muting input of this device can be set with the handy controller (**SFB-HC**) (optional). (Note 4, 5)

- **NONO (Normally Open, Normally Open)**

It is at the time of factory setting.

- **NONC (Normally Open, Normally Closed)**

Connect a sensor or switch whose output operation is NO (Normally Open) type to the muting input A and connect a sensor or switch whose output operation is NC (Normally Closed) type to the muting input B.

To make the muting function valid, time difference between the time during muting input A becomes ON from OFF (Open) and the time during muting input B becomes OFF (Open) from ON should be within 3 sec.

Function

<Output operations of muting sensors (when setting to NONC)>

	Muting input	Operation at ON state	Operation at OFF state
NO (Normally Open) type ON with light non-received status (photoelectric sensor, etc.) ON with object approaching status (inductive proximity sensor, etc.) ON with object contacted status (position switch, etc.)	A	Output 0V or +V	Open
NC (Normally Closed) type ON with light received status (photoelectric sensor, etc.) ON with object non-approaching status (inductive proximity sensor, etc.) ON with object non-contacted status (position switch, etc.)	B		

- Notes: 1) If a beam channel whose muting function is set to be invalid is blocked during the muting, the control output (OSSD 1 / 2) will be turned OFF and the muting function will be released.
- 2) The muting indicator diagnosis function can be set with the handy controller Ver. 2.1 (**SFB-HC**) (optional), but it must be set to invalid. If the muting indicator diagnosis function is set to valid, the muting function cannot be used.
- 3) Although the muting indicator diagnosis function will be valid when the handy controller (**SFB-HC**) (optional) initialization function is used, change the setting to invalid for the function if you are using the muting function.
- 4) Selectable with the handy controller Ver. 2.1 (**SFB-HC**) (optional).
- 5) The muting function will be invalid if the muting sensor which is connected to the muting input of this device differs from the output operation which is set with the handy controller (**SFB-HC**) (optional).

- **Override setting changing function (For SF4B-□CA-J05 only)**

Maximum continuous effective time set at the override function can be changed.

The maximum continuous effective time can be set in the range of 60 to 600 sec. (in units of 10 sec.).

Note: Selectable with the handy controller Ver.2.1 (**SFB-HC**) (optional).

- **Protective function**

Unless the password is inputted, any change in setting of the device is not allowed.

The factory setting is set to be invalid for the protective function.

<Reference>

When any errors are found, refer to “**Chapter 5 Troubleshooting**” and report the symptoms to the maintenance in charge. If the rectification method is not clear, please contact our office. Please make a copy of this checklist, check each inspection item in the respective square, and file the list for record.

4-1 Daily Inspection

WARNING

Be sure to inspect the following items prior to operation and confirm that there is no error. Operating this device without inspection or in an error condition can result in death or serious injury.

Check list (Daily inspection)

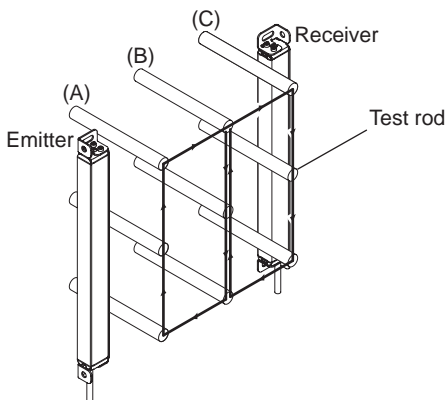
Check column	Inspection item
<input type="checkbox"/>	Dangerous parts of the machine cannot be reached without passing through the sensing area of this device.
<input type="checkbox"/>	Some part of operator's body remains in the sensing area when operation is done with dangerous parts of the machine.
<input type="checkbox"/>	The calculated safety distance has been maintained or exceeded during installation.
<input type="checkbox"/>	There is no damage to the safety guard or protective structure.
<input type="checkbox"/>	There is no defect, fold, or damage in the wiring.
<input type="checkbox"/>	The corresponding connectors have been connected securely.
<input type="checkbox"/>	No dirt or scratches exist on the light emitting surface.
<input type="checkbox"/>	The test rod is not deformed or defective.
<input type="checkbox"/>	The operation indicator (green) of the emitter and the OSSD indicator (green) of the receiver light up when no object is present in the sensing area. The control output (OSSD 1 / 2) is in ON status. At this time, the effect of external noise can be inspected. In case external noise affects the operation, remove its cause and reinspect.
<input type="checkbox"/>	<p>It should be possible to detect the test rod (ø25mm for SF4B-H□C□ or ø45mm for SF4B-A□C□) at three positions, directly in front of the emitter (A), midway between the emitter and the receiver (B), and directly in front of the receiver (C) when the test rod is moved at a speed of 1,600mm/sec. The OSSD indicator (red) of the receiver and the operation indicator (red) of the emitter continue to light up as long as the test rod is present in the sensing area from (A) to (C).</p> 
<input type="checkbox"/>	With the machine in the operating condition, the dangerous parts operate normally when no object is present in the sensing area.
<input type="checkbox"/>	With the machine in the operating condition, the dangerous parts stop immediately when the test rod is inserted into the sensing area at any of the three positions, directly in front of the emitter (A), midway between the emitter and the receiver (B), and directly in front of the receiver (C).
<input type="checkbox"/>	The dangerous parts remain stopped as long as the test rod is present in the sensing area.
<input type="checkbox"/>	The dangerous parts stop immediately when the power supply of this device is turned OFF.
<input type="checkbox"/>	The control output (OSSD 1 / 2) must turn OFF when the emission halt input / reset input wire (pink) is open (for manual reset: connected to 0V, +V). At this time, the effect of external noise can be inspected. In case external noise affects the operation, remove its cause and reinspect.
<input type="checkbox"/>	Be sure to check the operation of the muting function before its use. Furthermore, check the state of the muting indicator (cleanliness or brightness, etc.)

Maintenance

4-2 Periodic Inspection (Every Six Months)

 WARNING

Be sure to inspect the following items every six months and confirm that there is no error. Operating this device without inspection or in an error condition can result in death or serious injury.

Check list (Periodic inspection)

Check column	Inspection item
<input type="checkbox"/>	The structure of the machine does not obstruct any safety mechanism for stopping operation.
<input type="checkbox"/>	No modification has been made in the machine controls which obstructs the safety mechanisms.
<input type="checkbox"/>	The output of this device is correctly detected.
<input type="checkbox"/>	The wiring from this device is correct.
<input type="checkbox"/>	The overall response time of the complete machine is equal or less than the calculated value.
<input type="checkbox"/>	The actual number of operation cycle (time) of the limited lifetime parts (relay, etc.) is less than their rated operation cycles (time).
<input type="checkbox"/>	No screws or connectors of this device are loose.
<input type="checkbox"/>	No extraneous light source or reflective object has been added near this device.

4-3 Inspection after Maintenance

Under the following situations, perform all the inspection items mentioned in “4-1 Daily Inspection” and “4-2 Periodic Inspection (Every Six Months).”

- 1) When any parts of this device are replaced.
- 2) When some abnormality is felt during operation.
- 3) When beam-axis alignment of the emitter and receiver is done.
- 4) When the device installation place or environment is changed.
- 5) When the wiring method or wiring layout is changed.
- 6) When FSD (Final Switching Device) parts are replaced.
- 7) When FSD (Final Switching Device) setting is changed.

<Reference>

- Check the wiring.
- Check the power supply voltage and the power supply capacity.

5-1 Troubleshooting of Emitter

<All indicators are OFF>

Cause	Remedy
Power is not being supplied	Check that the power supply capacity is sufficient. Connect the power supply correctly.
Supply voltage is out of the specified range.	Set the supply voltage correctly.
Connector is not connected securely.	Connect the connector securely.

<Fault indicator (yellow) lights up or blinks>

Cause	Remedy	
[Lights up] Setting data error of this device	Noise is out of the specified range. Internal error	Check the noise status around this device. Increase the handy controller (SFB-HC) (optional) is applied, reset the function. Contact our office.
[Blinks 1 time] System error between emitter and receiver	Systems are different between emitter and receiver.	Set the same value to the numbers of emitter and receiver and that of beam channel, and the shield wires.
[Blinks 4 times] Interlock setting error	Voltage level of Interlock setting input wire (pale purple), or emission halt input / reset input wire (pink) is unstable.	Wire the Interlock setting input wire (pale purple) and emission halt input / reset input wire (pink) correctly. Refer to "2-5 Wiring."
[Blinks 5, 9 times] Muting auxiliary output error	Muting auxiliary output wire (red) short-circuits with other I/O wires.	Refer to "2-5 Wiring." Current value should be within the specified muting auxiliary output.
	Excessive incoming current flows in the muting auxiliary output.	
	Output polarity setting wire (shield) and muting auxiliary output wire (red) are not correctly wired.	Wire the output polarity setting wire (shield) correctly. (0V: PNP output, +V: NPN output). Wire the muting auxiliary output wire (red) correctly. Refer to "2-5 Wiring."
	Output circuit error	Output circuit is damaged. Replace this device.
[Blinks 6 times] Output polarity setting wire (shield) error	Output polarity setting wire (shield) comes down or short-circuits with other I/O wires. Output polarity setting wire (shield) connection of emitter / receiver is incorrect.	Wire the output polarity setting wire (shield) correctly. (0V: PNP output, +V: NPN output). Wire the output polarity setting wire (shield) of the receiver correctly.
[Blinks 10 times or more] Effect from noise / power supply or failure of internal circuit	Affected by noise / power supply. Internal circuit is broken down.	Check the noise status around this device. Check the wiring status, supply voltage, and power supply capacity. When the synchronization + wire (orange) and synchronization - wire (orange / black) is extended with a cable other than exclusive cable, use a 0.2mm ² or more shielded twisted pair cable. If this device still does not work, confirm number of blinks of the error indicator and call to our local office.

Troubleshooting

<Emission halt indicator (red) lights up>

Cause		Remedy
Emission is in halt condition (Device error or interlock setting error)	Error indicator (yellow) lights or blinks.	Check the contents of the fault indicator.
	Emission halt input / reset input wire (pink) is open when selecting auto-reset.	Wire the emission halt input / reset input (pink) wire to 0V or +V. Refer to "2-5 Wiring."
	Emission halt input / reset input wire (pink) is connected to 0V or +V when selecting manual reset.	Open the emission halt input / reset input (pink) wire. Refer to "2-5 Wiring."

<All beam-axis adjustment indicators (red) light up>

Cause	Remedy
The beam channel with its fixed blanking function set into valid receives light.	Turn ON the power supply after checking the installation status.

<Operation indicator remains lit in red (light is not received) (Note)>

Cause	Remedy
The beam channels are not correctly aligned.	The beam channels are not correctly aligned. Refer to "2-6 Adjustment." Align the top / bottom direction of the beam channel between emitter and receiver.
Sensing range is shortened because of the emission amount control function.	Reset to factory default (CLR) by the handy controller (SFB-HC) (optional).
Synchronization + wire (orange) or synchronization - wire (orange / black) error. Synchronization + wire (orange) or synchronization - wire (orange / black) comes down or short-circuits.	Connect synchronization + wire (orange) or synchronization + wire (orange / black) properly. Refer to "2-5 Wiring."

Note: Since the color of the operation indicator changes according to ON / OFF status of the control output (OSSD 1 / 2), the operation indicator is marked as "OSSD" on the device.

If the device does not work normally after checking the items above, please consult Panasonic Industrial Devices SUNX.

<Reference>

About counting blinks of the error indicator, count blinks from 2 seconds of no blinking.

5-2 Troubleshooting of Receiver

<All indicators are OFF>

Cause	Remedy
Power is not being supplied	Check that the power supply capacity is sufficient. Connect the power supply correctly.
Supply voltage is out of the specified range.	Set the supply voltage correctly.
Connector is not connected securely.	Connect the connector securely.

<Fault indicator (yellow) lights or blinks>

Cause	Remedy	
[Lights up] Setting data error of this device	Noise is out of the specified range. Internal error	Check the noise status around this device. Incase the handy controller (SFB-HC) (optional) is applied, reset the function. Contact our office.
[Blinks 1 times] System error between emitter and receiver	Systems are different between emitter and receiver.	Set the same value to the numbers of emitter and receiver and that of beam channel, and the shield wires.
[Blinks 4 times] Extraneous light error	Extraneous light is entering or light from other model is entering.	When the power is ON, prevent any extraneous light from entering the receiver. If the extraneous light is coming from this device, conduct " 2-3-4 Device Placement. "
[Blinks 5, 9 times] Control output (OSSD 1 / 2) error	Control output 1 (OSSD 1) wire (black) and control output 2 (OSSD 2) wire (white) short-circuits with 0V or +V.	Wire the control output 1 (OSSD 1) wire (black) or control output 2 (OSSD 2) wire (white) correctly. Refer to " 2-5 Wiring. " Current value should be within the specified control output 1 (OSSD 1) wire (black) or control output 2 (OSSD 2) wire (white). Refer to " 6-1 Specifications. "
	Control output 1 (OSSD 1) wire (black) or control output 2 (OSSD 2) wire (white) shortcircuit respectively, or shortcircuits with other I/O wires.	
	Excessive incoming current flows in the Control output 1 (OSSD 1) wire (black) and control output 2 (OSSD 2) wire (white).	
	Output polarity setting wire (shield) and control output 1 (OSSD 1) wire (black) and control output 2 (OSSD 2) wire (white) are not correctly wired.	
[Blinks 6 times] Output polarity setting wire (shield) error	Output polarity setting wire (shield) comes down or short-circuits with other I/O wires. Output polarity setting wire (shield) connection of emitter / receiver is incorrect.	Wire the output polarity setting wire (shield) correctly. (0V: PNP output, +V: NPN output). Wire the control output 1 (OSSD 1) wire (black) or control output 2 (OSSD 2) wire (white) correctly. (0V: PNP output, +V: NPN output). Refer to " 2-5 Wiring. "
	Output circuit error	Output circuit is damaged. Replace this device.

Troubleshooting

Cause		Remedy	
[Blinks 7 times] External device error	When using safety relay	Relay contact is welded.	Replace the relay.
		Response time of the relay is slow.	Replace the relay with proper response time. Setting by the handy controller (SFB-HC) (optional) is also possible. Refer to " 3-5 External Device Monitor Function. "
		Contacting point "b" of the relay is not wired.	Wire correctly to the relay.
	When setting the external device monitor function to "invalid."	Auxiliary output wire (yellow-green / black) and external device monitor input wire (yellow-green) are not wired.	Connect the auxiliary output wire (yellow-green / black) and the external device monitor input wire (yellow-green). Set the external device monitor function to "invalid" using the handy controller (SFB-HC) (optional).
		Auxiliary output is not correctly operated.	Check if the auxiliary output wire (yellow-green / black) is disconnected or short-circuited. Reset to factory default (mode 0) by the handy controller (SFB-HC) (optional).
[Blinks 10 times or more] Effect from noise / power supply or failure of internal circuit	Affected by noise / power supply. Internal circuit is broken down.	Check the noise status around this device. Check the wiring status, supply voltage, and power supply capacity. When the synchronization + wire (orange) and synchronization - wire (orange / black) is extended with a cable other than exclusive cable, use a 0.2mm ² or more shielded twisted pair cable. If this device still does not work, confirm number of blinks of the error indicator and call to our local office.	

<All beam-axis adjustment indicators (red) light up>

Cause	Remedy
The beam channel with its fixed blanking function set into valid receives light.	Turn ON the power supply after checking the installation status.

<Operation indicator remains lit in red (light is not received)>

Cause	Remedy
The beam channels are not correctly aligned.	The beam channels are not correctly aligned. Refer to " 2-6 Adjustment. " Align the top / bottom direction of the beam channel between emitter and receiver.
Synchronization + wire (orange) or synchronization - wire (orange / black) error. Synchronization + wire (orange) or synchronization - wire (orange / black) comes down or short-circuits.	Connect synchronization + wire (orange) or synchronization - wire (orange / black) properly. Refer to " 2-5 Wiring. "

If the device does not work normally after checking the items above, please consult Panasonic Industrial Devices SUNX.

<Reference>

About counting blinks of the error indicator, count blinks from 2 seconds of no blinking.

6-1 Specifications

Model

SF4B - □ □ C □ - □

<Cable specification>

Blank: Cable type, **J05**: Relay connector type

<Large multi-purpose indicator, Muting function>

Blank: Unmounted, **A**: Mounted

<Number of beam channels>

<Beam pitch>

H: 20mm, **A**: 40mm

Example: **SF4B-H32CA-J05**

Number of beam channels: 32 channels

Beam pitch: 20mm

Large multi-purpose indicator: Mounted

Cable specification: Relay connector type

Specifications

Model-wise specifications <20mm pitch type>

Type		20mm pitch type			
Model	Cable type	SF4B-H12C	SF4B-H16C	SF4B-H20C	SF4B-H24C
	Relay connector type	SF4B-H12CA-J05	SF4B-H16CA-J05	SF4B-H20CA-J05	SF4B-H24CA-J05
Number of beam channels		12	16	20	24
Protective height		263.4	343.4	423.4	503.4
Current consumption	Cable type	Emitter: 65mA or less, Receiver: 75mA or less			Emitter: 70mA or less Receiver: 85mA or less
	Relay connector type	When large multi-purpose indicator turns OFF	Emitter: 65mA or less, Receiver: 75mA or less		Emitter: 70mA or less Receiver: 85mA or less
		When large multi-purpose indicator lights up	Emitter: 75mA or less, Receiver: 85mA or less		Emitter: 80mA or less Receiver: 95mA or less
PFHd		1.9×10^{-9}	2.1×10^{-9}	2.4×10^{-9}	2.6×10^{-9}
MTTFd		More than 100 years			
Weight (total of emitter and receiver)	Cable type	Approx. 700g	Approx. 770g	Approx. 860g	Approx. 930g
	Relay connector type	Approx. 360g	Approx. 430g	Approx. 520g	Approx. 590g

Type		20mm pitch type			
Model	Cable type	SF4B-H28C	SF4B-H32C	SF4B-H36C	SF4B-H40C
	Relay connector type	SF4B-H28CA-J05	SF4B-H32CA-J05	SF4B-H36CA-J05	SF4B-H40CA-J05
Number of beam channels		28	32	36	40
Protective height		583.4	663.4	743.4	823.4
Current consumption	Cable type	Emitter: 70mA or less Receiver: 85mA or less	Emitter: 75mA or less, Receiver: 95mA or less		Emitter: 80mA or less Receiver: 100mA or less
	Relay connector type	When large multi-purpose indicator turns OFF	Emitter: 75mA or less, Receiver: 95mA or less		Emitter: 80mA or less Receiver: 100mA or less
		When large multi-purpose indicator lights up	Emitter: 80mA or less Receiver: 95mA or less	Emitter: 85mA or less, Receiver: 105mA or less	
PFHd		2.8×10^{-9}	3.0×10^{-9}	3.3×10^{-9}	3.5×10^{-9}
MTTFd		More than 100 years			
Weight (total of emitter and receiver)	Cable type	Approx. 1,000g	Approx. 1,100g	Approx. 1,200g	Approx. 1,300g
	Relay connector type	Approx. 680g	Approx. 750g	Approx. 840g	Approx. 910g

PFHd: Probability of dangerous failure per hour, MTTFd: Mean time to dangerous failure.

Type		20mm pitch type			
Model	Cable type	SF4B-H48C	SF4B-H56C	SF4B-H64C	SF4B-H72C
	Relay connector type	SF4B-H48CA-J05	SF4B-H56CA-J05	SF4B-H64CA-J05	SF4B-H72CA-J05
Number of beam channels		48	56	64	72
Protective height		983.4	1,143.4	1,303.4	1,463.4
Current consumption	Cable type	Emitter: 80mA or less Receiver: 100mA or less	Emitter: 85mA or less, Receiver: 120mA or less		Emitter: 95mA or less Receiver: 130mA or less
	Relay connector type	When large multi-purpose indicator turns OFF	Emitter: 85mA or less, Receiver: 120mA or less		Emitter: 95mA or less Receiver: 130mA or less
		When large multi-purpose indicator lights up	Emitter: 90mA or less Receiver: 110mA or less	Emitter: 95mA or less, Receiver: 130mA or less	
PFHd		3.9×10^{-9}	4.4×10^{-9}	4.8×10^{-9}	5.3×10^{-9}
MTTFd		More than 100 years			
Weight (total of emitter and receiver)	Cable type	Approx. 1,400g	Approx. 1,600g	Approx. 1,700g	Approx. 2,000g
	Relay connector type	Approx. 1,100g	Approx. 1,300g	Approx. 1,400g	Approx. 1,600g

Type		20mm pitch type			
Model	Cable type	SF4B-H80C	SF4B-H88C	SF4B-H96C	
	Relay connector type	SF4B-H80CA-J05	SF4B-H88CA-J05	SF4B-H96CA-J05	
Number of beam channels		80	88	96	
Protective height		1,623.4	1,783.4	1,943.4	
Current consumption	Cable type	Emitter: 95mA or less Receiver: 130mA or less	Emitter: 100mA or less Receiver: 140mA or less	Emitter: 105mA or less Receiver: 145mA or less	
	Relay connector type	When large multi-purpose indicator turns OFF	Emitter: 95mA or less Receiver: 130mA or less	Emitter: 100mA or less Receiver: 140mA or less	Emitter: 105mA or less Receiver: 145mA or less
		When large multi-purpose indicator lights up	Emitter: 105mA or less Receiver: 140mA or less	Emitter: 110mA or less Receiver: 150mA or less	Emitter: 115mA or less Receiver: 155mA or less
PFHd		5.7×10^{-9}	6.2×10^{-9}	6.6×10^{-9}	
MTTFd		More than 100 years			
Weight (total of emitter and receiver)	Cable type	Approx. 2,000g	Approx. 2,100g	Approx. 2,200g	
	Relay connector type	Approx. 1,700g	Approx. 1,800g	Approx. 1,900g	

PFHd: Probability of dangerous failure per hour, MTTFd: Mean time to dangerous failure.

Specifications

<40mm pitch type>

Type		40mm pitch type				
Model	Cable type	SF4B-A8C	SF4B-A12C	SF4B-A16C	SF4B-A20C	
	Relay connector type	SF4B-A8CA-J05	SF4B-A12CA-J05	SF4B-A16CA-J05	SF4B-A20CA-J05	
Number of beam channels		8	12	16	20	
Protective height		343.4	503.4	663.4	823.4	
Current consumption	Cable type	Emitter: 60mA or less, Receiver: 70mA or less		Emitter: 65mA or less, Receiver: 75mA or less		
	Relay connector type	When large multi-purpose indicator turns OFF	Emitter: 60mA or less, Receiver: 70mA or less		Emitter: 65mA or less, Receiver: 75mA or less	
		When large multi-purpose indicator lights up	Emitter: 70mA or less, Receiver: 80mA or less		Emitter: 75mA or less, Receiver: 85mA or less	
PFHd		1.7×10^{-9}	1.9×10^{-9}	2.2×10^{-9}	2.4×10^{-9}	
MTTFd		More than 100 years				
Weight (total of emitter and receiver)	Cable type	Approx. 770g	Approx. 930g	Approx. 1,100g	Approx. 1,300g	
	Relay connector type	Approx. 430g	Approx. 590g	Approx. 750g	Approx. 910g	

Type		40mm pitch type				
Model	Cable type	SF4B-A24C	SF4B-A28C	SF4B-A32C	SF4B-A36C	
	Relay connector type	SF4B-A24CA-J05	SF4B-A28CA-J05	SF4B-A32CA-J05	SF4B-A36CA-J05	
Number of beam channels		24	28	32	36	
Protective height		983.4	1,143.4	1,303.4	1,463.4	
Current consumption	Cable type	Emitter: 70mA or less, Receiver: 85mA or less		Emitter: 75mA or less, Receiver: 95mA or less		
	Relay connector type	When large multi-purpose indicator turns OFF	Emitter: 70mA or less, Receiver: 85mA or less		Emitter: 75mA or less, Receiver: 95mA or less	
		When large multi-purpose indicator lights up	Emitter: 80mA or less, Receiver: 95mA or less		Emitter: 85mA or less, Receiver: 105mA or less	
PFHd		2.7×10^{-9}	2.9×10^{-9}	3.2×10^{-9}	3.4×10^{-9}	
MTTFd		More than 100 years				
Weight (total of emitter and receiver)	Cable type	Approx. 1,400g	Approx. 1,600g	Approx. 1,700g	Approx. 2,000g	
	Relay connector type	Approx. 1,100g	Approx. 1,300g	Approx. 1,400g	Approx. 1,600g	

PFHd: Probability of dangerous failure per hour, MTTFd: Mean time to dangerous failure.

Type		40mm pitch type		
Model	Cable type	SF4B-A40C	SF4B-A44C	SF4B-A48C
	Relay connector type	SF4B-A40CA-J05	SF4B-A44CA-J05	SF4B-A48CA-J05
Number of beam channels		40	44	48
Protective height		1,623.4	1,783.4	1,943.4
Current consumption	Cable type	Emitter: 75mA or less Receiver: 95mA or less	Emitter: 80mA or less, Receiver: 100mA or less	
	Relay connector type	When large multi-purpose indicator turns OFF	Emitter: 75mA or less Receiver: 95mA or less	
		When large multi-purpose indicator lights up	Emitter: 85mA or less Receiver: 105mA or less	
PFHd		3.7×10^{-9}	3.9×10^{-9}	4.2×10^{-9}
MTTFd		More than 100 years		
Weight (total of emitter and receiver)	Cable type	Approx. 2,000g	Approx. 2,100g	Approx. 2,200g
	Relay connector type	Approx. 1,700g	Approx. 1,800g	Approx. 1,900g

PFHd: Probability of dangerous failure per hour, MTTFd: Mean time to dangerous failure.

Specifications

Common specifications

Type	20mm pitch type		40mm pitch type	
	Cable type	Relay connector type (With a large multi-purpose indicator)	Cable type	Relay connector type (With a large multi-purpose indicator)
Model	SF4B-H□C	SF4B-H□CA-J05	SF4B-A□C	SF4B-A□CA-J05
Sensing range	0.3 to 7m			
Minimum sensing object	ø25mm opaque object		ø45mm opaque object	
Effective aperture angle (EAA)	±2.5 degree or less [for sensing range exceeding 3m (Required by IEC 61496-2, ANSI/UL 61496-2)]			
Supply voltage	24V DC ±10% Ripple P-P10% or less			
Control output (OSSD 1 / 2)	PNP open-collector / NPN open-collector transistor (switching type)			
	<For PNP output> • Maximum source current: 200mA • Applied voltage: Same as supply voltage (between the control output and +V) • Residual voltage: 2.5V or less (source current 200mA, when using 20m length cable) • Leakage current: 0.1mA or less (Including power supply OFF condition) • Maximum load capacity: 0.22µF (No load to maximum output current) • Load wiring resistance: 3Ω or less		<For NPN output> • Maximum sink current: 200mA • Applied voltage: Same as supply voltage (between the control output and 0V) • Residual voltage: 2.5V or less (sink current 200mA, when using 20m length cable) • Leakage current: 0.1mA or less (Including power supply OFF condition) • Maximum load capacity: 0.22µF (No load to maximum output current) • Load wiring resistance: 3Ω or less	
Operation mode (Output operation)	ON when all beams are received, OFF when one or more beams are interrupted (OFF when fault occurs in the sensor to the synchronization single error, too)			
Protection circuit (Short-circuit)	Incorporated			
Response time	When OFF: 14ms or less, When ON: 80 to 90ms			
Auxiliary output (AUX) (Non-safety output)	PNP open-collector / NPN open-collector transistor (switching type)			
	<For PNP output> • Maximum source current: 60mA • Applied voltage: Same as supply voltage (between the auxiliary output and +V) • Residual voltage: 2.5V or less (source current 60mA, when using 20m length cable)		<For NPN output> • Maximum sink current: 60mA • Applied voltage: Same as supply voltage (between the auxiliary output and 0V) • Residual voltage: 2.5V or less (sink current 60mA, when using 20m length cable)	
Operation mode (Output operation)	When OSSDs are ON: OFF, when OSSDs are OFF: ON (factory setting) [Changeable by using the handy controller (SFB-HC) (optional).]			
Protection circuit (Short-circuit)	Incorporated			
Muting auxiliary output (For SF4B-□CA-J05 only)	NPN open-collector transistor			
	• Maximum sink current: 100mA • Applied voltage: Same as supply voltage (between the muting auxiliary output and 0V) • Residual voltage: 2.5V or less (sink current 100mA, when using 20m length cable)			
Operation mode (Output operation)	When muting auxiliary output: ON			
Protection circuit (Short-circuit)	Incorporated			
Protection	IP65(IEC)			
Degree of pollution	3			
Ambient temperature	-10 to +55°C (No dew condensation or icing allowed), Storage:-25 to +60°C			
Ambient humidity	30 to 85%RH, Strage: 30 to 85%RH			
Ambient illuminance	Incandescent lamp: 3,500lx or less at the light-receiving surface			
Operating altitude	2,000m or less (Note 1)			
Voltage with standability	1,000V AC for one min. (between all supply terminals connected together and enclosure)			
Insulation resistance	20MΩ or more with 500V DC mega (between all supply terminals connected together and enclosure)			
Vibration resistance	10 to 55Hz frequency, 0.75mm amplitude in X, Y, and Z directions for two hours each			
Shock resistance	300m/s ² acceleration (Approx. 30G) in X, Y and Z directions for three times each			

Type	20mm pitch type		40mm pitch type	
	Cable type	Relay connector type (With a large multi- purpose indicator)	Cable type	Relay connector type (With a large multi- purpose indicator)
Model	SF4B-H□C	SF4B-H□CA-J05	SF4B-A□C	SF4B-A□CA-J05
SFF (Safe failure fraction)	99%			
HFT (Hardware failure tolerance)	1			
Subsystem type	Type B (IEC 61508-2)			
Mission time	20 years			
Emitting element	Infrared LED (Peak emission wavelength: 850nm)			
Cable	Cable type: 0.15mm ² (power supply line: 0.2mm ²) 8-core heat-resistant PVC cable, 5m long Relay connector type: 0.15mm ² (power supply line: 0.2mm ²) 12-core heat-resistant PVC cable with connector, 0.5m long			
Cable extension	Cable type: Extension up to total 50m is possible for 0.2mm ² or more, cable (Note 2) Relay connector type: Extension up to total 50m is possible for both emitter and receiver connecting cable (optional)			
Material	Enclosure: Polycarbonate, MS-SF4BC-1 (Standard mounting bracket): SUS			
Accessory	SF4B-TR25 (Test rod): 1 pc.		-	
Applicable standard	EN 61496-1 (Type 4), EN 55011, EN 61000-6-2, EN 50178 EN ISO 13849-1: 2008 (Category 4, PL _e), IEC 61496-1/2 (Type 4) ISO 13849-1: 2006 (Category 4, PL _e), IEC 61508-1 to 7 (SIL3), JIS B 9704-1/2 (Type 4) JIS B 9705-1 (Category 4), JIS C 0508 (SIL3), ANSI/UL 61496-1/2 (Type 4) ANSI/UL 508			

Notes: 1) Do not use or store the device in an environment where the air pressure is higher than the atmospheric pressure at an altitude of 0 meters.

- 2) When the synchronization + wire (orange) and synchronization - wire (orange / black) is extended with a cable other than exclusive cable, use a 0.2mm² or more shielded twisted pair cable.

Options

6-2 Options

- 12-core extension cable with connector on one end: 2 pcs./set

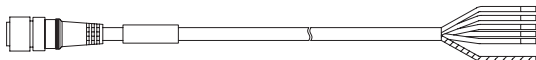

Type	Model No.	Cable length	Remarks
Discrete wire	SFB-CC3-MU	3m	This cable is used for extending the cable of SF4B-□CA-J05 . For emitter: Gray connector, 12-core shielded cable For receiver: Black connector, 12-core shielded cable
	SFB-CC7-MU	7m	
	SFB-CC10-MU	10m	

- 12-core extension cable with connectors on both ends: 1 pc.

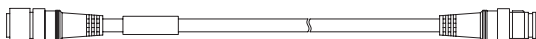

Type	Model No.	Cable length	Remarks
For emitter	SFB-CCJ3E-MU	3m	This cable is used for extending the cable of SF4B-□CA-J05 . The connector is attached on both ends of the cable.
	SFB-CCJ10E-MU	10m	
For receiver	SFB-CCJ3D-MU	3m	For emitter: Gray connector, 12-core shielded cable For receiver: Black connector, 12-core shielded cable
	SFB-CCJ10D-MU	10m	

- Standard mounting bracket: 4 pcs./set [L type: 2 pcs., R type: 2 pcs.]

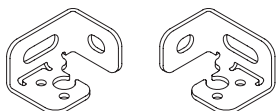

Model No.	Remarks
MS-SF4BC-1	This mounting bracket allows the device to be mounted at the rear or the side. For one hexagon-socket head bolt [M5]. <Accessory> Hexagon-socket head bolt [M3 (length: 5mm)]: 8 pcs. M5 flat washer: 4 pcs.

- Rear utility mounting bracket: 4 pcs./set [L type: 2 pcs., R type: 2 pcs.]

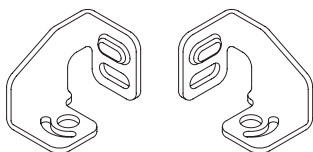

Model No.	Remarks
MS-SF4BC-2	This mounting bracket lets you adjust the beam axis and mount the device in confined spaces. For one hexagon-socket head bolt [M5]. Use one hexagon head bolt [M5] when installation space is limited. <Accessory> Hexagon-socket head bolt [M3 (length: 6mm)]: 8 pcs. M5 flat washer: 4 pcs.

- Side utility mounting bracket: 4 pcs./set [L type: 2 pcs., R type: 2 pcs.]

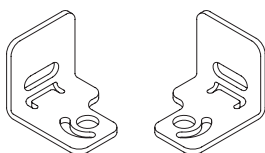

Model No.	Remarks
MS-SF4BC-3	This mounting bracket lets you adjust the beam axis and mount the device in confined spaces. For one hexagon-socket head bolt [M5]. Use one hexagon head bolt [M5] when installation space is limited. <Accessory> Hexagon-socket head bolt [M3 (length: 6mm)]: 8 pcs. M5 flat washer: 4 pcs.

● **Intermediate supporting bracket for use with utility mounting bracket: (Note)**
[For rear mounting: 2 pcs., For side mounting: 2 pcs.]

<Rear mounting>

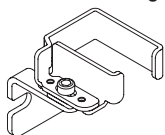

<Side mounting>

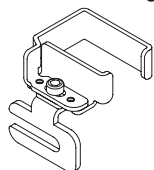

Assembly drawing shown above.

Model No.	Remarks
MS-SF4BC-4	This bracket is used to support the middle of the unit when mounting it using the utility mounting bracket. It can be used to mount the unit from the rear or side. This mounting bracket lets you adjust the beam axis and mount the device in confined spaces. For one hexagon head bolt [M5]. <Accessory> M5 flat washer: 2 pcs.

Note: The numbers of sets required by **SF4B-H□C□** (40 or more beam axes) and **SF4B-A□C□** (20 or more beam axes) are as follows:

SF4B-H40C□, SF4B-H48C□, SF4B-H56C□, SF4B-A20C□, SF4B-A24C□, SF4B-A28C□: 1 set
SF4B-H64C□, SF4B-H72C□, SF4B-H80C□, SF4B-H88C□, SF4B-H96C□, SF4B-A32C□, SF4B-A36C□, SF4B-A40C□, SF4B-A44C□, SF4B-A48C□: 2 sets

● **Intermediate supporting bracket for use with standard mounting bracket: (Note)**
[For rear mounting: 2 pcs., For side mounting: 2 pcs.]

<Rear mounting>

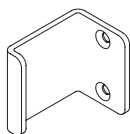

<Side mounting>

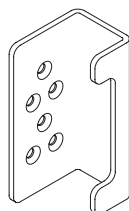

Model No.	Remarks
MS-S4BC-5	This bracket is used to support the middle of the unit when mounting it using the standard mounting bracket. It can be used to mount the unit from the rear or side. For two M3 flat head screws.

Note: The numbers of sets required by **SF4B-H□C□** (40 or more beam axes) and **SF4B-A□C□** (20 or more beam axes) are as follows:

SF4B-H40C□, SF4B-H48C□, SF4B-H56C□, SF4B-A20C□, SF4B-A24C□, SF4B-A28C□: 1 set
SF4B-H64C□, SF4B-H72C□, SF4B-H80C□, SF4B-H88C□, SF4B-H96C□, SF4B-A32C□, SF4B-A36C□, SF4B-A40C□, SF4B-A44C□, SF4B-A48C□: 2 sets

● **Side mounting bracket: 4 pcs./set [L type: 2 pcs., R type: 2 pcs.]**

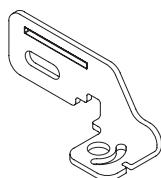
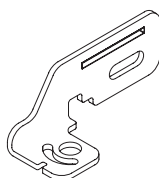

Model No.	Remarks
MS-SF4BC-6	This mounting bracket lets you adjust the beam axis and mount the device in confined spaces. For one hexagon-socket head bolt [M5]. <Accessory> Hexagon-socket head bolt [M3 (length: 6mm)]: 8 pcs. M5 flat washer: 4 pcs.

● **Intermediate supporting bracket for use with side mounting bracket: 2 pcs./set (Note)**

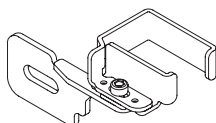

Assembly drawing shown above.

Model No.	Remarks
MS-SF4BC-7	This bracket is used to support the middle of the unit when mounting it using the side mounting bracket. This mounting bracket lets you adjust the beam axis and mount the device in confined spaces. For one hexagon-socket head bolt [M5]. <Accessory> M5 flat washer: 2 pcs.

Note: The numbers of sets required by **SF4B-H□C□** (40 or more beam axes) and **SF4B-A□C□** (20 or more beam axes) are as follows:

SF4B-H40C□, SF4B-H48C□, SF4B-H56C□, SF4B-A20C□, SF4B-A24C□, SF4B-A28C□: 1 set
SF4B-H64C□, SF4B-H72C□, SF4B-H80C□, SF4B-H88C□, SF4B-H96C□, SF4B-A32C□, SF4B-A36C□, SF4B-A40C□, SF4B-A44C□, SF4B-A48C□: 2 sets

Options

- Protective metal case: 2 pcs./set

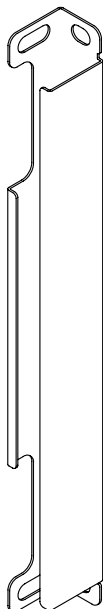

Model No.	Applicable model		Weight (total)	Remarks
MS-SF4BCH-12	SF4B-H12C(A-J05)	–	Approx. 400g	Protects the machine from collision by a sensing object. In the case of using a protective metal case, make sure to assemble it with a standard mounting bracket MS-SF4BC-1 (optional).
MS-SF4BCH-16	SF4B-H16C(A-J05)	SF4B-A8C(A-J05)	Approx. 510g	
MS-SF4BCH-20	SF4B-H20C(A-J05)	–	Approx. 620g	
MS-SF4BCH-24	SF4B-H24C(A-J05)	SF4B-A12C(A-J05)	Approx. 730g	
MS-SF4BCH-28	SF4B-H28C(A-J05)	–	Approx. 840g	
MS-SF4BCH-32	SF4B-H32C(A-J05)	SF4B-A16C(A-J05)	Approx. 950g	
MS-SF4BCH-36	SF4B-H36C(A-J05)	–	Approx. 1,100g	
MS-SF4BCH-40	SF4B-H40C(A-J05)	SF4B-A20C(A-J05)	Approx. 1,200g	
MS-SF4BCH-48	SF4B-H48C(A-J05)	SF4B-A24C(A-J05)	Approx. 1,400g	
MS-SF4BCH-56	SF4B-H56C(A-J05)	SF4B-A28C(A-J05)	Approx. 1,600g	
MS-SF4BCH-64	SF4B-H64C(A-J05)	SF4B-A32C(A-J05)	Approx. 1,800g	
MS-SF4BCH-72	SF4B-H72C(A-J05)	SF4B-A36C(A-J05)	Approx. 2,000g	
MS-SF4BCH-80	SF4B-H80C(A-J05)	SF4B-A40C(A-J05)	Approx. 2,300g	
MS-SF4BCH-88	SF4B-H88C(A-J05)	SF4B-A44C(A-J05)	Approx. 2,500g	
MS-SF4BCH-96	SF4B-H96C(A-J05)	SF4B-A48C(A-J05)	Approx. 2,700g	

- Thin type control unit: 1 pc.

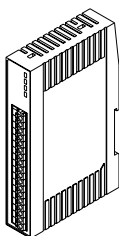

Model No.	Remarks
SF-C13	This is the controller conforming to European / North American safety standards.

- Handy controller: 1 pc.

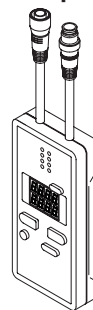

Model No.	Remarks
SFB-HC	Handy controller that enables setting each function. When used for cable type SF4B-□C , Cable set SFC-WNC1 (optional) for a cable type connection is required.

- Test rod: 1 pc.

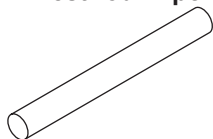

Model No.	Remarks
SF4B-TR45	Test rod for SF4B-A□C□ . ø45mm It can be also used for SF4B-H□C□ 1 beam channel floating.

6-3 Dimensions

6-3-1 Rear Mounting with MS-SF4BC-1 and MS-SF4BC-5

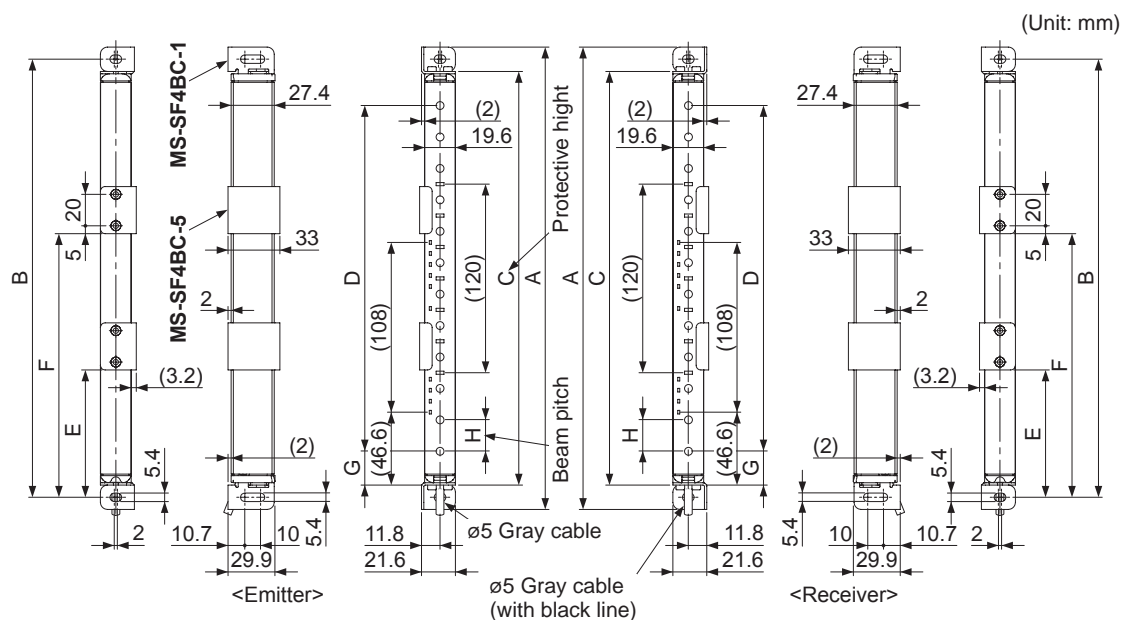

<SF4B-□CA-J05>

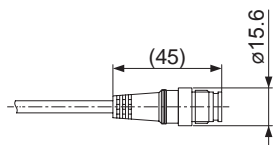

Model No.	A	B	C	D		E	F
				SF4B-H□C□	SF4B-A□C□		
SF4B-H12C(A-J05)	-	294.4	279	263.4	220	-	-
SF4B-H16C(A-J05)	SF4B-A8C(A-J05)	374.4	359	343.4	300	280	-
SF4B-H20C(A-J05)	-	454.4	439	423.4	380	-	-
SF4B-H24C(A-J05)	SF4B-A12C(A-J05)	534.4	519	503.4	460	440	-
SF4B-H28C(A-J05)	-	614.4	599	583.4	540	-	-
SF4B-H32C(A-J05)	SF4B-A16C(A-J05)	694.4	679	663.4	620	600	-
SF4B-H36C(A-J05)	-	774.4	759	743.4	700	-	-
SF4B-H40C(A-J05)	SF4B-A20C(A-J05)	854.4	839	823.4	780	760	395
SF4B-H48C(A-J05)	SF4B-A24C(A-J05)	1,014.4	999	983.4	940	920	475
SF4B-H56C(A-J05)	SF4B-A28C(A-J05)	1,174.4	1,159	1,143.4	1,100	1,080	555
SF4B-H64C(A-J05)	SF4B-A32C(A-J05)	1,334.4	1,319	1,303.4	1,260	1,240	415
SF4B-H72C(A-J05)	SF4B-A36C(A-J05)	1,494.4	1,479	1,463.4	1,420	1,400	468
SF4B-H80C(A-J05)	SF4B-A40C(A-J05)	1,654.4	1,639	1,623.4	1,580	1,560	521
SF4B-H88C(A-J05)	SF4B-A44C(A-J05)	1,814.4	1,799	1,783.4	1,740	1,720	574
SF4B-H96C(A-J05)	SF4B-A48C(A-J05)	1,974.4	1,959	1,943.4	1,900	1,880	627

Type	G	H
SF4B-H□C□	21.7	20
SF4B-A□C□	41.7	40

Dimensions

6-3-2 Side Mounting with MS-SF4BC-1 and MS-SF4BC-5

(Unit: mm)

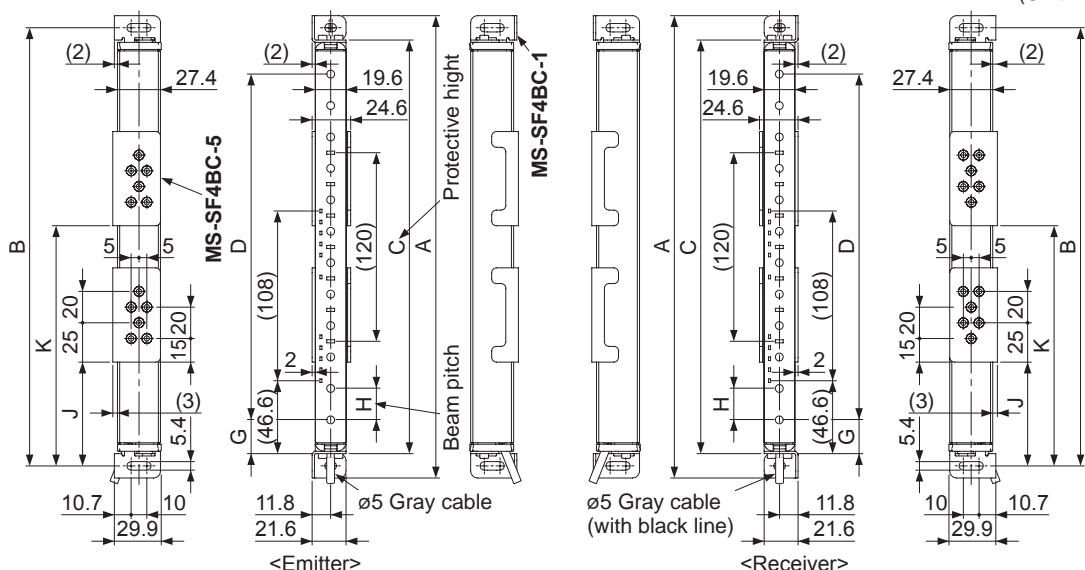

<SF4B-□CA-J05>

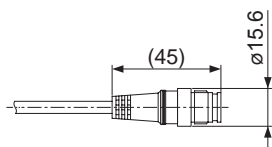

Model No.		A	B	C	D		J	K
					SF4B-H□C□	SF4B-A□C□		
SF4B-H12C(A-J05)	-	294.4	279	263.4	220	-	-	-
SF4B-H16C(A-J05)	SF4B-A8C(A-J05)	374.4	359	343.4	300	280	-	-
SF4B-H20C(A-J05)	-	454.4	439	423.4	380	-	-	-
SF4B-H24C(A-J05)	SF4B-A12C(A-J05)	534.4	519	503.4	460	440	-	-
SF4B-H28C(A-J05)	-	614.4	599	583.4	540	-	-	-
SF4B-H32C(A-J05)	SF4B-A16C(A-J05)	694.4	679	663.4	620	600	-	-
SF4B-H36C(A-J05)	-	774.4	759	743.4	700	-	-	-
SF4B-H40C(A-J05)	SF4B-A20C(A-J05)	854.4	839	823.4	780	760	390	-
SF4B-H48C(A-J05)	SF4B-A24C(A-J05)	1,014.4	999	983.4	940	920	470	-
SF4B-H56C(A-J05)	SF4B-A28C(A-J05)	1,174.4	1,159	1,143.4	1,100	1,080	550	-
SF4B-H64C(A-J05)	SF4B-A32C(A-J05)	1,334.4	1,319	1,303.4	1,260	1,240	410	849
SF4B-H72C(A-J05)	SF4B-A36C(A-J05)	1,494.4	1,479	1,463.4	1,420	1,400	463	956
SF4B-H80C(A-J05)	SF4B-A40C(A-J05)	1,654.4	1,639	1,623.4	1,580	1,560	516	1,063
SF4B-H88C(A-J05)	SF4B-A44C(A-J05)	1,814.4	1,799	1,783.4	1,740	1,720	569	1,170
SF4B-H96C(A-J05)	SF4B-A48C(A-J05)	1,974.4	1,959	1,943.4	1,900	1,880	622	1,277

Type	G	H
SF4B-H□C□	21.7	20
SF4B-A□C□	41.7	40

6-3-3 Rear Mounting with MS-SF4BC-2 and MS-SF4BC-4

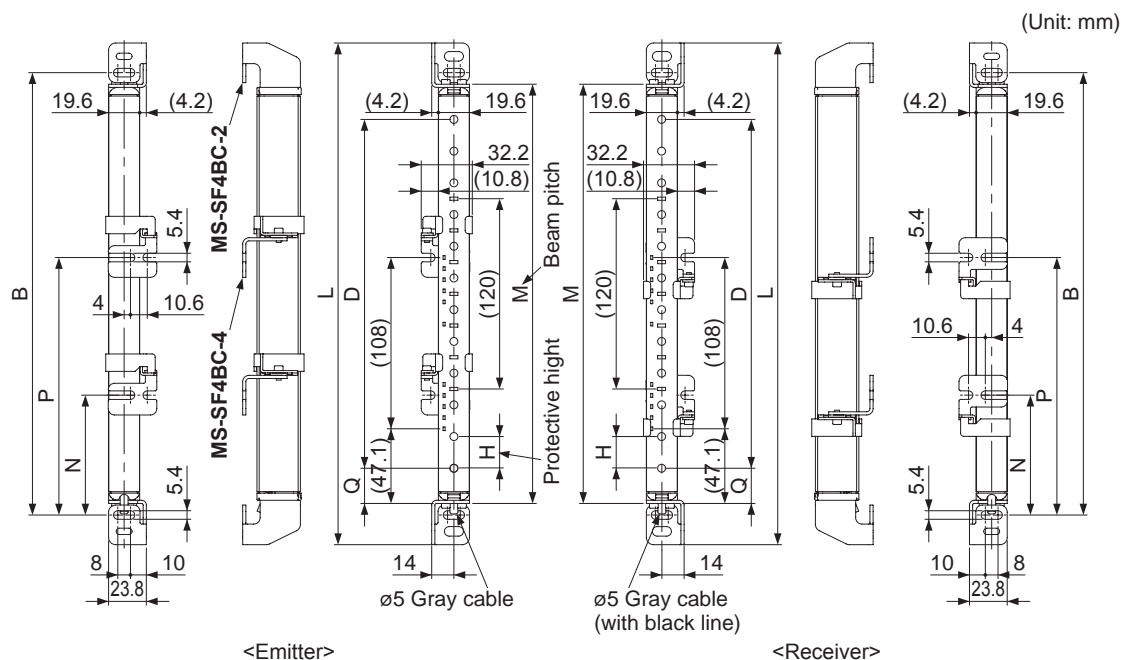

<SF4B-□CA-J05>

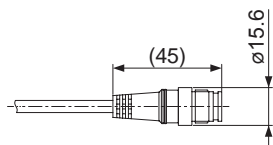

Model No.	B	D		L	M	N	P	
		SF4B-H□C□	SF4B-A□C□					
SF4B-H12C(A-J05)	-	279	220	-	316.4	264.4	-	-
SF4B-H16C(A-J05)	SF4B-A8C(A-J05)	359	300	280	396.4	344.4	-	-
SF4B-H20C(A-J05)	-	439	380	-	476.4	424.4	-	-
SF4B-H24C(A-J05)	SF4B-A12C(A-J05)	519	460	440	556.4	504.4	-	-
SF4B-H28C(A-J05)	-	599	540	-	636.4	584.4	-	-
SF4B-H32C(A-J05)	SF4B-A16C(A-J05)	679	620	600	716.4	664.4	-	-
SF4B-H36C(A-J05)	-	759	700	-	796.4	744.4	-	-
SF4B-H40C(A-J05)	SF4B-A20C(A-J05)	839	780	760	876.4	824.4	399.5	-
SF4B-H48C(A-J05)	SF4B-A24C(A-J05)	999	940	920	1,036.4	984.4	479.5	-
SF4B-H56C(A-J05)	SF4B-A28C(A-J05)	1,159	1,100	1,080	1,196.4	1,144.4	559.5	-
SF4B-H64C(A-J05)	SF4B-A32C(A-J05)	1,319	1,260	1,240	1,356.4	1,304.4	419.5	858.5
SF4B-H72C(A-J05)	SF4B-A36C(A-J05)	1,479	1,420	1,400	1,516.4	1,464.4	472.5	965.5
SF4B-H80C(A-J05)	SF4B-A40C(A-J05)	1,639	1,580	1,560	1,676.4	1,624.4	525.5	1,072.5
SF4B-H88C(A-J05)	SF4B-A44C(A-J05)	1,799	1,740	1,720	1,836.4	1,784.4	578.5	1,179.5
SF4B-H96C(A-J05)	SF4B-A48C(A-J05)	1,959	1,900	1,880	1,996.4	1,944.4	631.5	1,286.5

Type	H	Q
SF4B-H□C□	20	22.2
SF4B-A□C□	40	42.2

Dimensions

6-3-4 In Case Mounting in Confined Space with MS-SF4BC-2 and MS-SF4BC-4

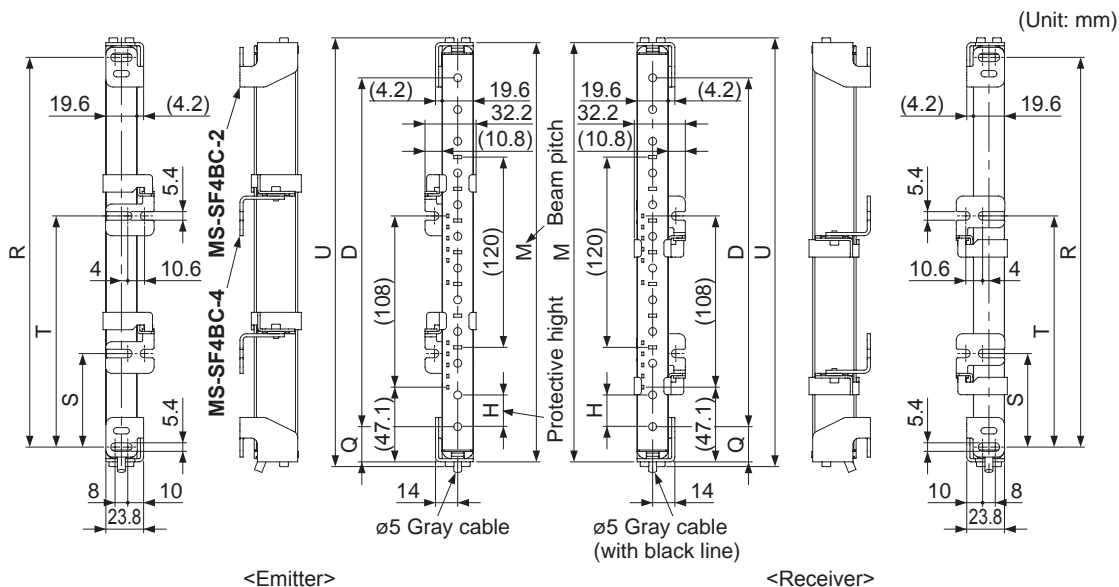

<SF4B-□CA-J05>

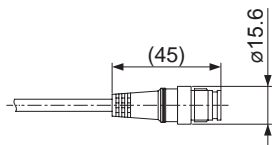

Model No.	D		M	R	S	T	U
	SF4B-H□C□	SF4B-A□C□					
SF4B-H12C(A-J05)	-	220	264.4	245.8	-	-	270.4
SF4B-H16C(A-J05)	SF4B-A8C(A-J05)	300	344.4	325.8	-	-	350.4
SF4B-H20C(A-J05)	-	380	424.4	405.8	-	-	430.4
SF4B-H24C(A-J05)	SF4B-A12C(A-J05)	460	504.4	485.8	-	-	510.4
SF4B-H28C(A-J05)	-	540	584.4	565.8	-	-	590.4
SF4B-H32C(A-J05)	SF4B-A16C(A-J05)	620	664.4	645.8	-	-	670.4
SF4B-H36C(A-J05)	-	700	744.4	725.8	-	-	750.4
SF4B-H40C(A-J05)	SF4B-A20C(A-J05)	780	824.4	805.8	382.9	-	830.4
SF4B-H48C(A-J05)	SF4B-A24C(A-J05)	940	984.4	965.8	462.9	-	990.4
SF4B-H56C(A-J05)	SF4B-A28C(A-J05)	1,100	1,144.4	1,125.8	542.9	-	1,150.4
SF4B-H64C(A-J05)	SF4B-A32C(A-J05)	1,260	1,304.4	1,285.8	402.9	841.9	1,310.4
SF4B-H72C(A-J05)	SF4B-A36C(A-J05)	1,420	1,464.4	1,445.8	455.9	948.9	1,470.4
SF4B-H80C(A-J05)	SF4B-A40C(A-J05)	1,580	1,624.4	1,605.8	508.9	1,055.9	1,630.4
SF4B-H88C(A-J05)	SF4B-A44C(A-J05)	1,740	1,784.4	1,765.8	561.9	1,162.9	1,790.4
SF4B-H96C(A-J05)	SF4B-A48C(A-J05)	1,900	1,944.4	1,925.8	614.9	1,269.9	1,950.4

Type	H	Q
SF4B-H□C□	20	22.2
SF4B-A□C□	40	42.2

6-3-5 Side Mounting with MS-SF4BC-3 and MS-SF4BC-4

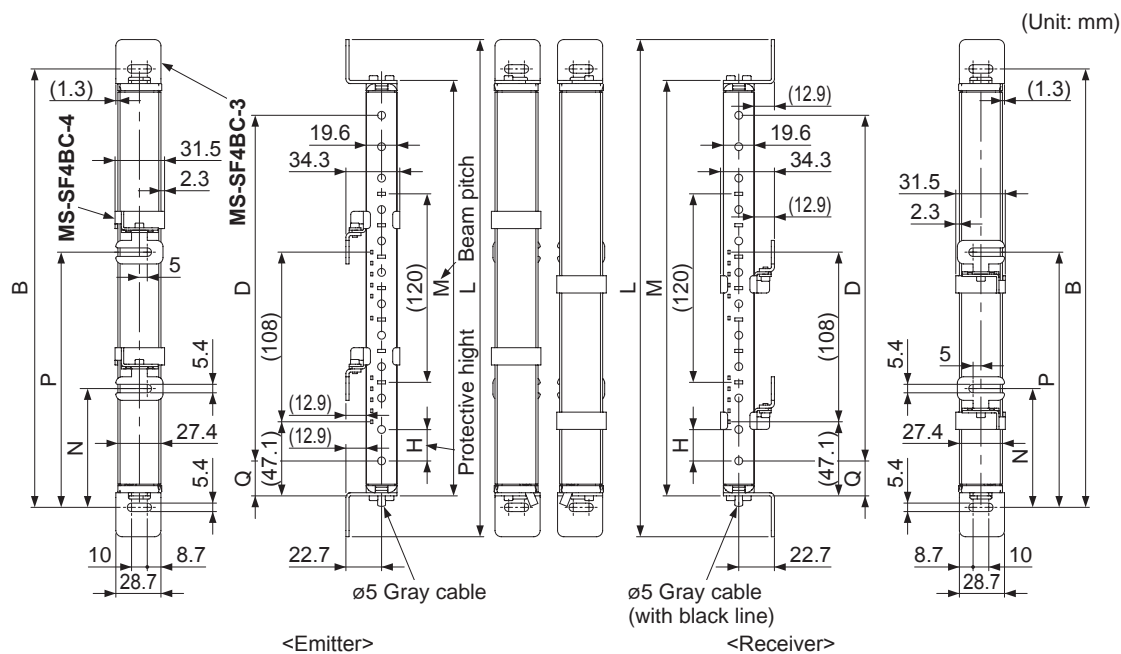

<SF4B-□CA-J05>

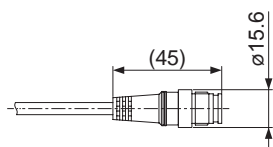

Model No.	B	D		L	M	N	P
		SF4B-H□C□	SF4B-A□C□				
SF4B-H12C(A-J05)	-	279	220	-	316.4	264.4	-
SF4B-H16C(A-J05)	SF4B-A8C(A-J05)	359	300	280	396.4	344.4	-
SF4B-H20C(A-J05)	-	439	380	-	476.4	424.4	-
SF4B-H24C(A-J05)	SF4B-A12C(A-J05)	519	460	440	556.4	504.4	-
SF4B-H28C(A-J05)	-	599	540	-	636.4	584.4	-
SF4B-H32C(A-J05)	SF4B-A16C(A-J05)	679	620	600	716.4	664.4	-
SF4B-H36C(A-J05)	-	759	700	-	796.4	744.4	-
SF4B-H40C(A-J05)	SF4B-A20C(A-J05)	839	780	760	876.4	824.4	399.5
SF4B-H48C(A-J05)	SF4B-A24C(A-J05)	999	940	920	1,036.4	984.4	479.5
SF4B-H56C(A-J05)	SF4B-A28C(A-J05)	1,159	1,100	1,080	1,196.4	1,144.4	559.5
SF4B-H64C(A-J05)	SF4B-A32C(A-J05)	1,319	1,260	1,240	1,356.4	1,304.4	419.5
SF4B-H72C(A-J05)	SF4B-A36C(A-J05)	1,479	1,420	1,400	1,516.4	1,464.4	472.5
SF4B-H80C(A-J05)	SF4B-A40C(A-J05)	1,639	1,580	1,560	1,676.4	1,624.4	525.5
SF4B-H88C(A-J05)	SF4B-A44C(A-J05)	1,799	1,740	1,720	1,836.4	1,784.4	578.5
SF4B-H96C(A-J05)	SF4B-A48C(A-J05)	1,959	1,900	1,880	1,996.4	1,944.4	631.5

Type	H	Q
SF4B-H□C□	20	22.2
SF4B-A□C□	40	42.2

Dimensions

6-3-6 In Case Mounting in Confined Space with MS-SF4BC-3 and MS-SF4BC-4

(Unit: mm)

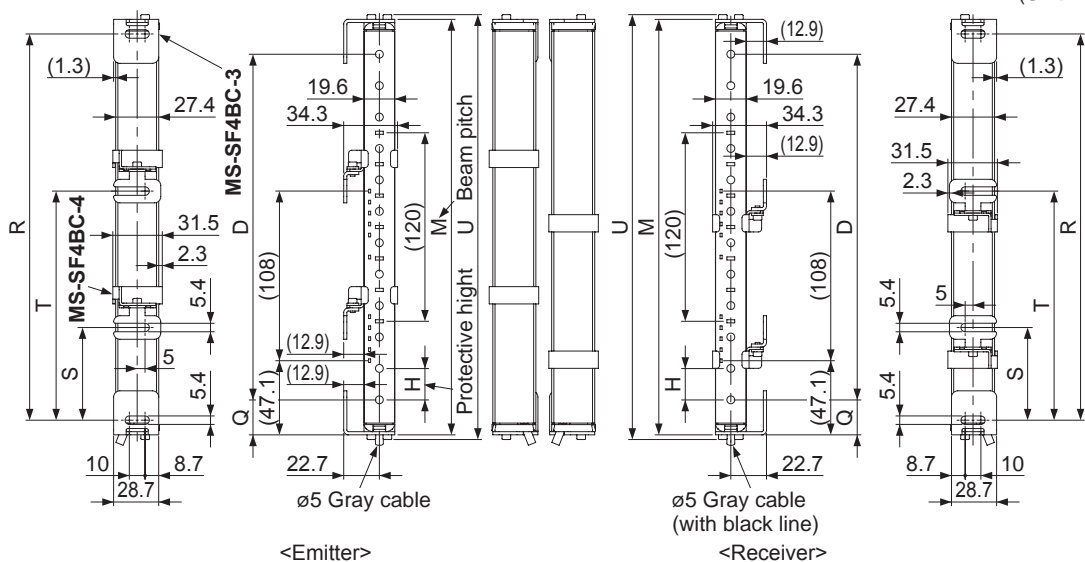

<SF4B-□CA-J05>

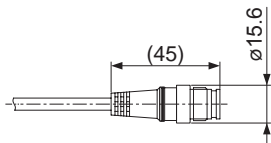

Model No.	D		M	R	S	T	U	
	SF4B-H□C□	SF4B-A□C□						
SF4B-H12C(A-J05)	-	220	-	264.4	245.8	-	-	270.4
SF4B-H16C(A-J05)	SF4B-A8C(A-J05)	300	280	344.4	325.8	-	-	350.4
SF4B-H20C(A-J05)	-	380	-	424.4	405.8	-	-	430.4
SF4B-H24C(A-J05)	SF4B-A12C(A-J05)	460	440	504.4	485.8	-	-	510.4
SF4B-H28C(A-J05)	-	540	-	584.4	565.8	-	-	590.4
SF4B-H32C(A-J05)	SF4B-A16C(A-J05)	620	600	664.4	645.8	-	-	670.4
SF4B-H36C(A-J05)	-	700	-	744.4	725.8	-	-	750.4
SF4B-H40C(A-J05)	SF4B-A20C(A-J05)	780	760	824.4	805.8	382.9	-	830.4
SF4B-H48C(A-J05)	SF4B-A24C(A-J05)	940	920	984.4	965.8	462.9	-	990.4
SF4B-H56C(A-J05)	SF4B-A28C(A-J05)	1,100	1,080	1,144.4	1,125.8	542.9	-	1,150.4
SF4B-H64C(A-J05)	SF4B-A32C(A-J05)	1,260	1,240	1,304.4	1,285.8	402.9	841.9	1,310.4
SF4B-H72C(A-J05)	SF4B-A36C(A-J05)	1,420	1,400	1,464.4	1,445.8	455.9	948.9	1,470.4
SF4B-H80C(A-J05)	SF4B-A40C(A-J05)	1,580	1,560	1,624.4	1,605.8	508.9	1,055.9	1,630.4
SF4B-H88C(A-J05)	SF4B-A44C(A-J05)	1,740	1,720	1,784.4	1,765.8	561.9	1,162.9	1,790.4
SF4B-H96C(A-J05)	SF4B-A48C(A-J05)	1,900	1,880	1,944.4	1,925.8	614.9	1,269.9	1,950.4

Type	H	Q
SF4B-H□C□	20	22.2
SF4B-A□C□	40	42.2

6-3-7 Mounting with MS-SF4BC-6 and MS-SF4BC-7

(Unit: mm)

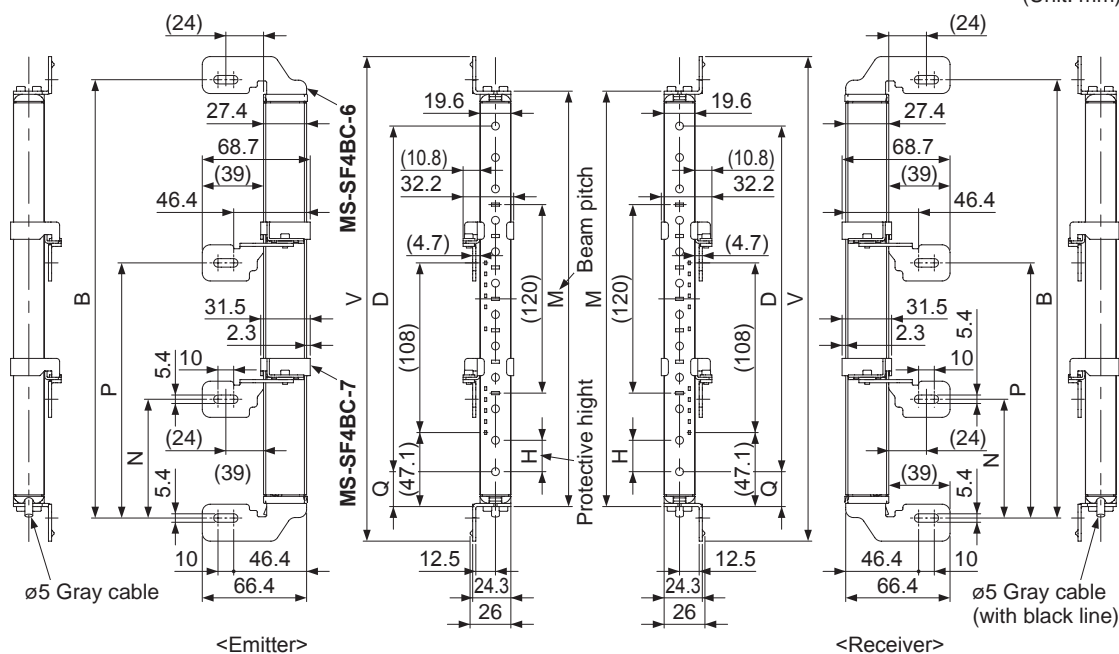

<SF4B-□CA-J05>

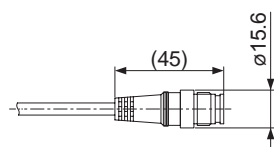

Model No.	B	D		M	N	P	V
		SF4B-H□C□	SF4B-A□C□				
SF4B-H12C(A-J05)	279	220	-	264.4	-	-	308.4
SF4B-H16C(A-J05)	359	300	280	344.4	-	-	388.4
SF4B-H20C(A-J05)	439	380	-	424.4	-	-	468.4
SF4B-H24C(A-J05)	519	460	440	504.4	-	-	548.4
SF4B-H28C(A-J05)	599	540	-	584.4	-	-	628.4
SF4B-H32C(A-J05)	679	620	600	664.4	-	-	708.4
SF4B-H36C(A-J05)	759	700	-	744.4	-	-	788.4
SF4B-H40C(A-J05)	839	780	760	824.4	399.5	-	868.4
SF4B-H48C(A-J05)	999	940	920	984.4	479.5	-	1,028.4
SF4B-H56C(A-J05)	1,159	1,100	1,080	1,144.4	559.5	-	1,188.4
SF4B-H64C(A-J05)	1,319	1,260	1,240	1,304.4	419.5	858.5	1,348.4
SF4B-H72C(A-J05)	1,479	1,420	1,400	1,464.4	472.5	965.5	1,508.4
SF4B-H80C(A-J05)	1,639	1,580	1,560	1,624.4	525.5	1,072.5	1,668.4
SF4B-H88C(A-J05)	1,799	1,740	1,720	1,784.4	578.5	1,179.5	1,828.4
SF4B-H96C(A-J05)	1,959	1,900	1,880	1,944.4	631.5	1,286.5	1,988.4

Type	H	Q
SF4B-H□C□	20	22.2
SF4B-A□C□	40	42.2

Dimensions

6-3-8 In Case Mounting in Confined Space with MS-SF4BC-6 and MS-SF4BC-7

(Unit: mm)

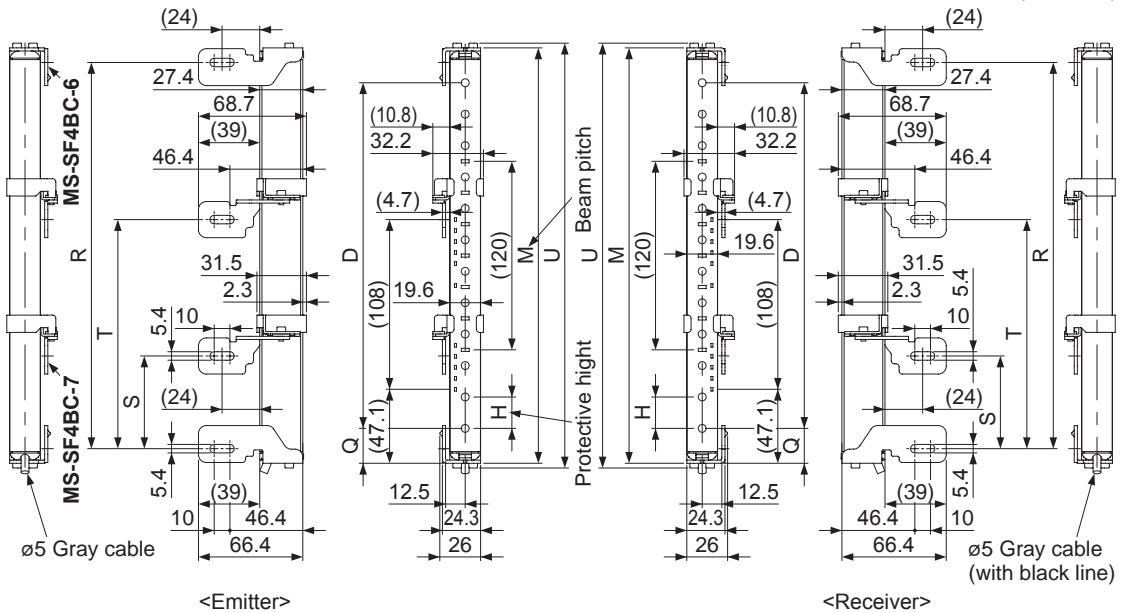

<SF4B-□CA-J05>

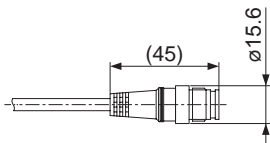

Model No.	D		M	R	S	T	U
	SF4B-H□C□	SF4B-A□C□					
SF4B-H12C(A-J05)	-	220	264.4	245.8	-	-	270.4
SF4B-H16C(A-J05)	SF4B-A8C(A-J05)	300	344.4	325.8	-	-	350.4
SF4B-H20C(A-J05)	-	380	424.4	405.8	-	-	430.4
SF4B-H24C(A-J05)	SF4B-A12C(A-J05)	460	504.4	485.8	-	-	510.4
SF4B-H28C(A-J05)	-	540	584.4	565.8	-	-	590.4
SF4B-H32C(A-J05)	SF4B-A16C(A-J05)	620	664.4	645.8	-	-	670.4
SF4B-H36C(A-J05)	-	700	744.4	725.8	-	-	750.4
SF4B-H40C(A-J05)	SF4B-A20C(A-J05)	780	824.4	805.8	382.9	-	830.4
SF4B-H48C(A-J05)	SF4B-A24C(A-J05)	940	984.4	965.8	462.9	-	990.4
SF4B-H56C(A-J05)	SF4B-A28C(A-J05)	1,100	1,144.4	1,125.8	542.9	-	1,150.4
SF4B-H64C(A-J05)	SF4B-A32C(A-J05)	1,260	1,304.4	1,285.8	402.9	841.9	1,310.4
SF4B-H72C(A-J05)	SF4B-A36C(A-J05)	1,420	1,464.4	1,445.8	455.9	948.9	1,470.4
SF4B-H80C(A-J05)	SF4B-A40C(A-J05)	1,580	1,624.4	1,605.8	508.9	1,055.9	1,630.4
SF4B-H88C(A-J05)	SF4B-A44C(A-J05)	1,740	1,784.4	1,765.8	561.9	1,162.9	1,790.4
SF4B-H96C(A-J05)	SF4B-A48C(A-J05)	1,900	1,944.4	1,925.8	614.9	1,269.9	1,950.4

Type	H	Q
SF4B-H□C□	20	22.2
SF4B-A□C□	40	42.2

6-3-9 Mounting with MS-SF4BCH-□ and MS-SF4BC-1

(Unit: mm)

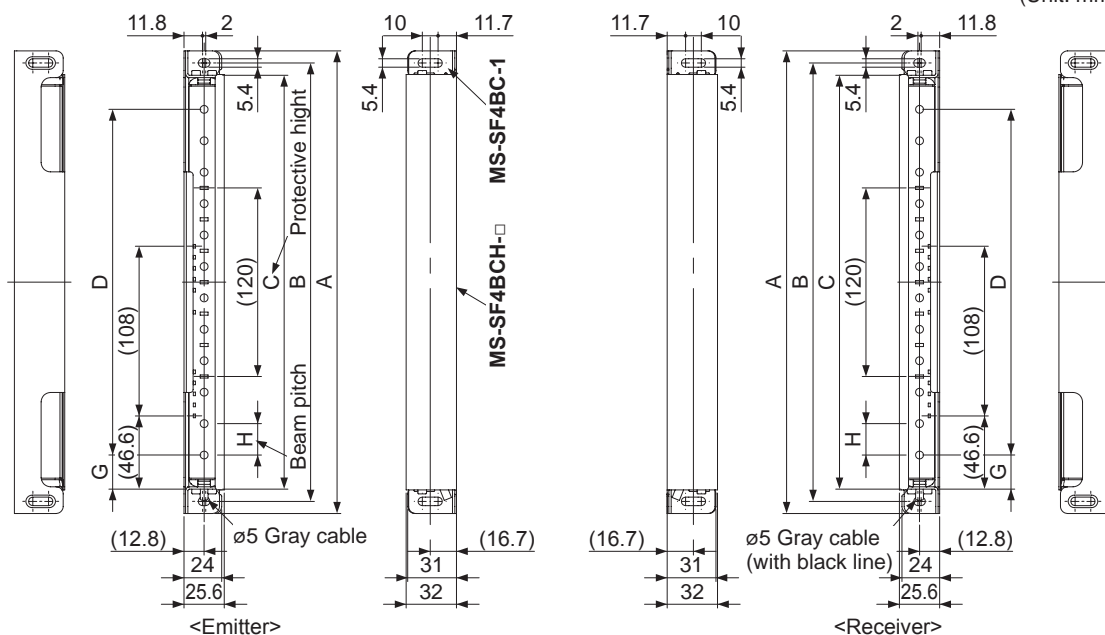

<SF4B-□CA-J05>

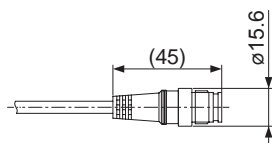

Model No.	A	B	C	D		
				SF4B-H□C□	SF4B-A□C□	
SF4B-H12C(A-J05)	-	294.4	279	263.4	220	-
SF4B-H16C(A-J05)	SF4B-A8C(A-J05)	374.4	359	343.4	300	280
SF4B-H20C(A-J05)	-	454.4	439	423.4	380	-
SF4B-H24C(A-J05)	SF4B-A12C(A-J05)	534.4	519	503.4	460	440
SF4B-H28C(A-J05)	-	614.4	599	583.4	540	-
SF4B-H32C(A-J05)	SF4B-A16C(A-J05)	694.4	679	663.4	620	600
SF4B-H36C(A-J05)	-	774.4	759	743.4	700	-
SF4B-H40C(A-J05)	SF4B-A20C(A-J05)	854.4	839	823.4	780	760
SF4B-H48C(A-J05)	SF4B-A24C(A-J05)	1,014.4	999	983.4	940	920
SF4B-H56C(A-J05)	SF4B-A28C(A-J05)	1,174.4	1,159	1,143.4	1,100	1,080
SF4B-H64C(A-J05)	SF4B-A32C(A-J05)	1,334.4	1,319	1,303.4	1,260	1,240
SF4B-H72C(A-J05)	SF4B-A36C(A-J05)	1,494.4	1,479	1,463.4	1,420	1,400
SF4B-H80C(A-J05)	SF4B-A40C(A-J05)	1,654.4	1,639	1,623.4	1,580	1,560
SF4B-H88C(A-J05)	SF4B-A44C(A-J05)	1,814.4	1,799	1,783.4	1,740	1,720
SF4B-H96C(A-J05)	SF4B-A48C(A-J05)	1,974.4	1,959	1,943.4	1,900	1,880

Type	G	H
SF4B-H□C□	21.7	20
SF4B-A□C□	41.7	40

Dimensions

6-3-10 Mounting Brackets

(Unit: mm)

1) Standard mounting bracket / MS-SF4BC-1

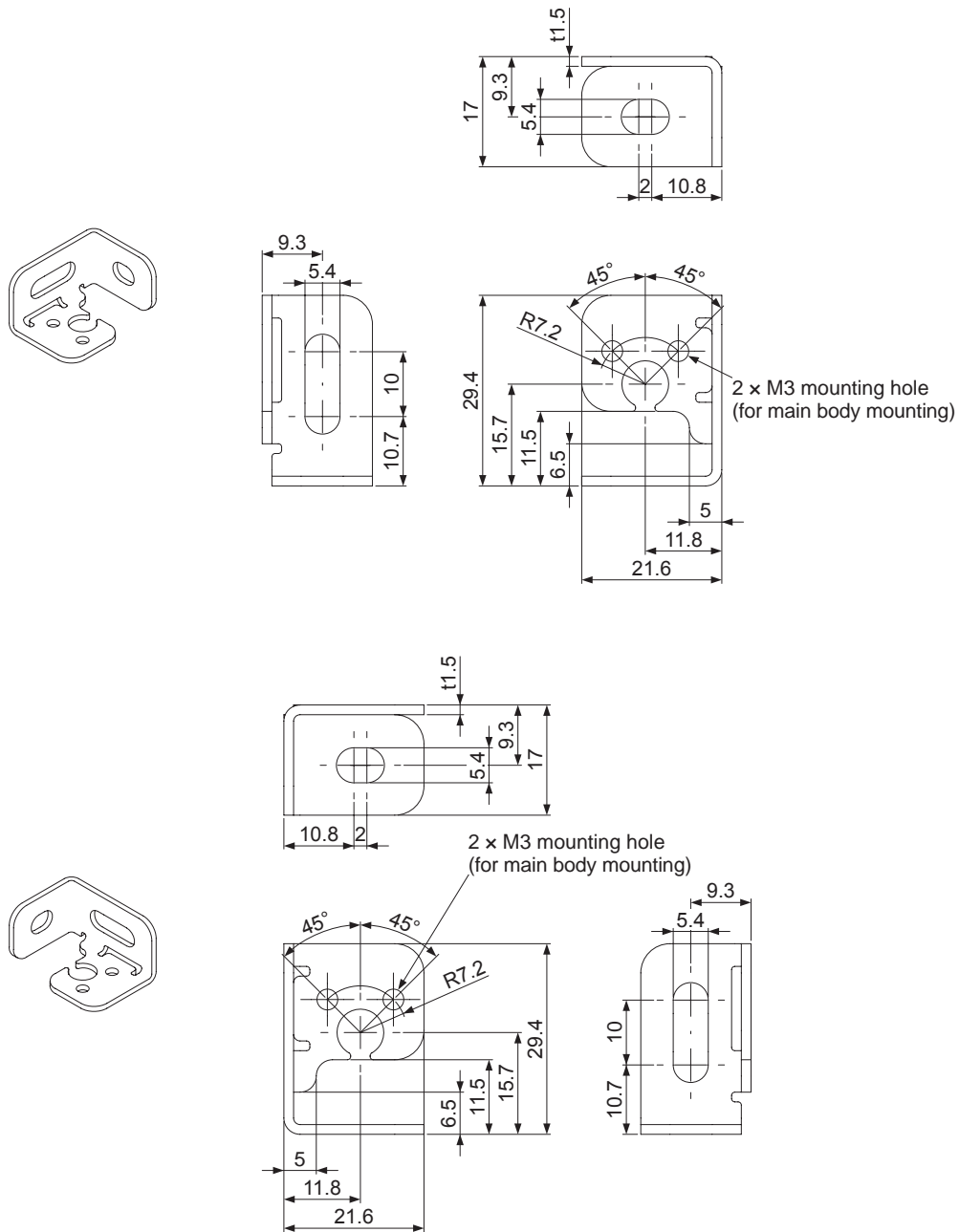

2) Rear utility mounting bracket / MS-SF4BC-2

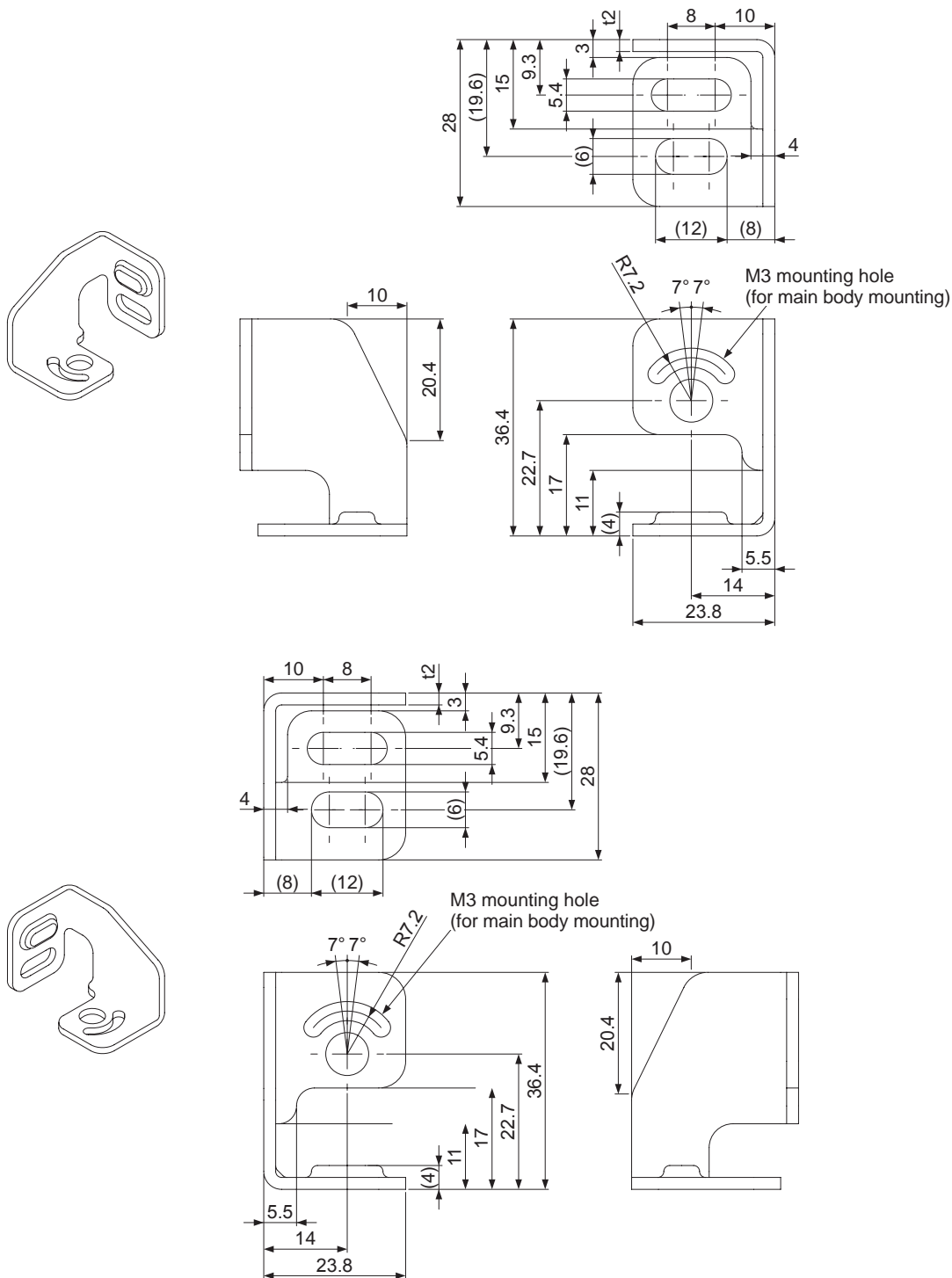

Material: Stainless steel

Dimensions

3) Side utility mounting bracket / MS-SF4BC-3

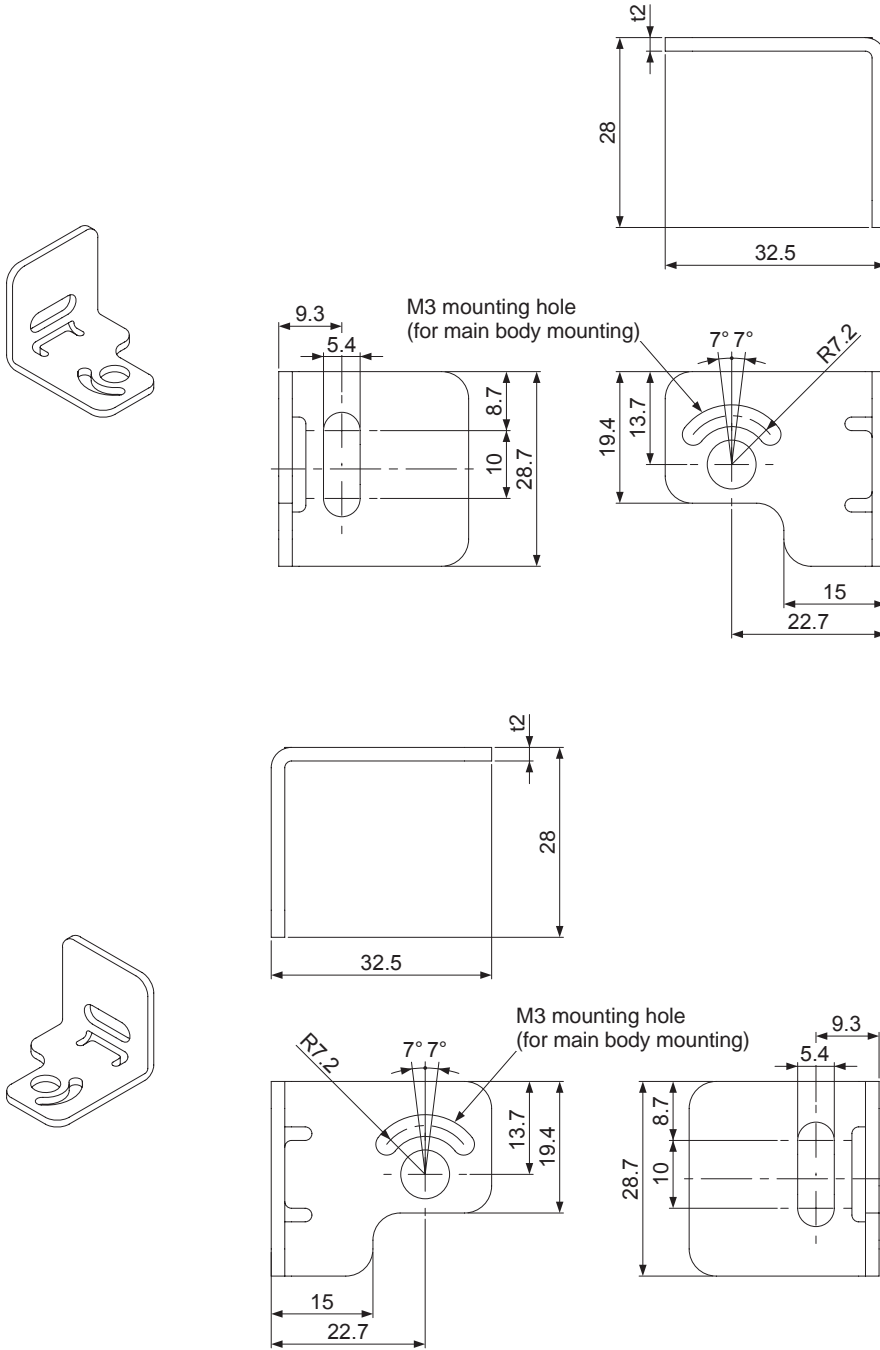

Material: Stainless steel

4) Intermediate support bracket for use with utility mounting bracket / MS-SF4BC-4

<Rear mounting>

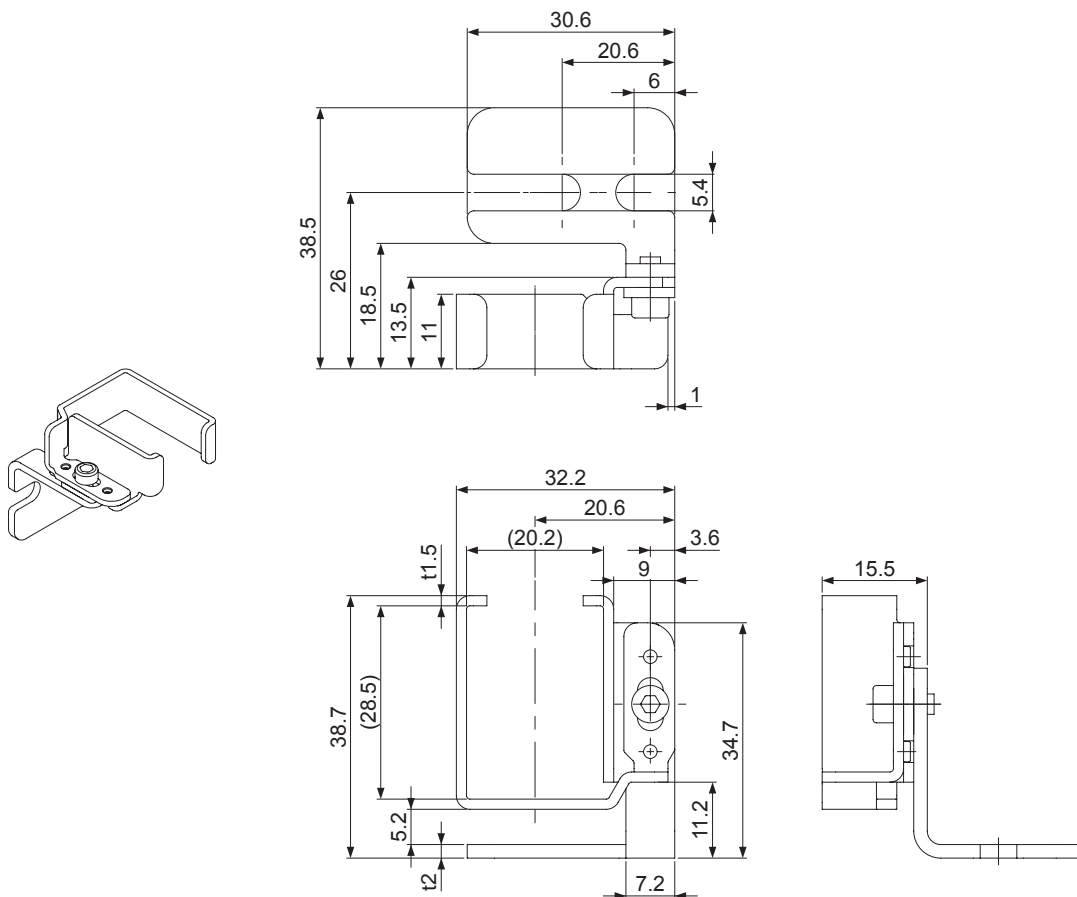

Material: Stainless steel

Dimensions

<Side mounting>

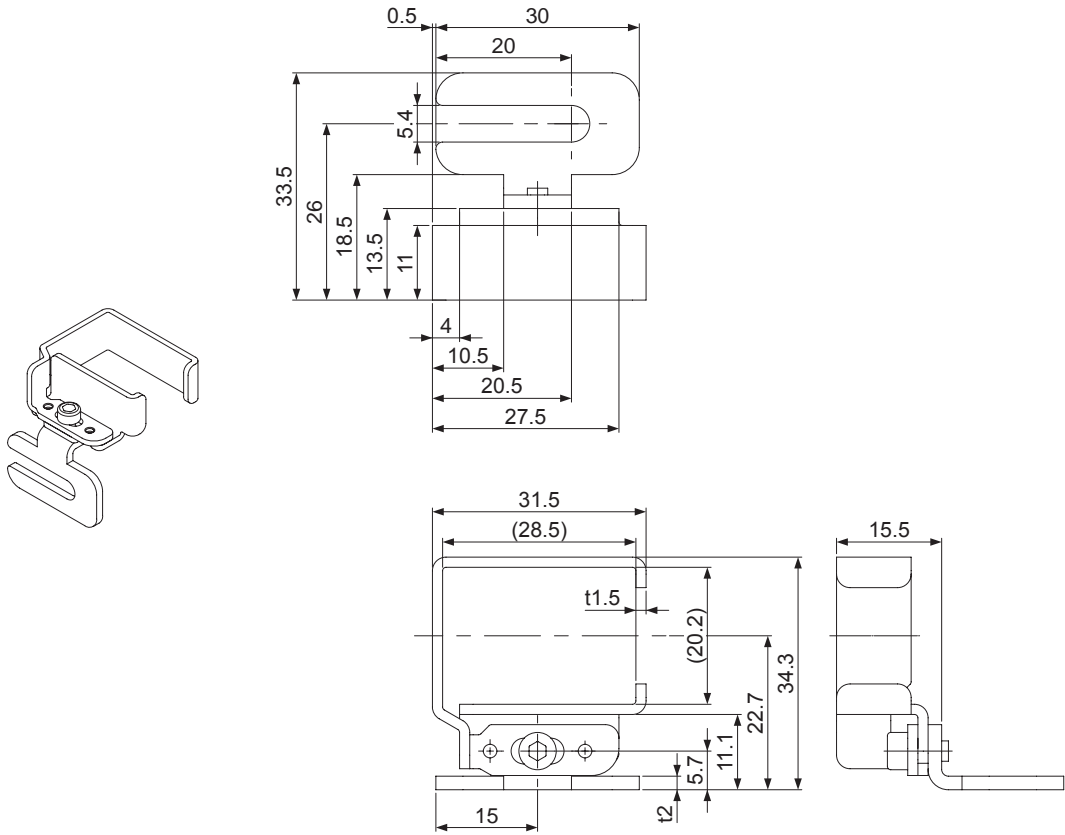

Material: Stainless steel

5) Intermediate supporting bracket for use with the standard mounting bracket / MS-SF4BC-5

<Rear mounting>

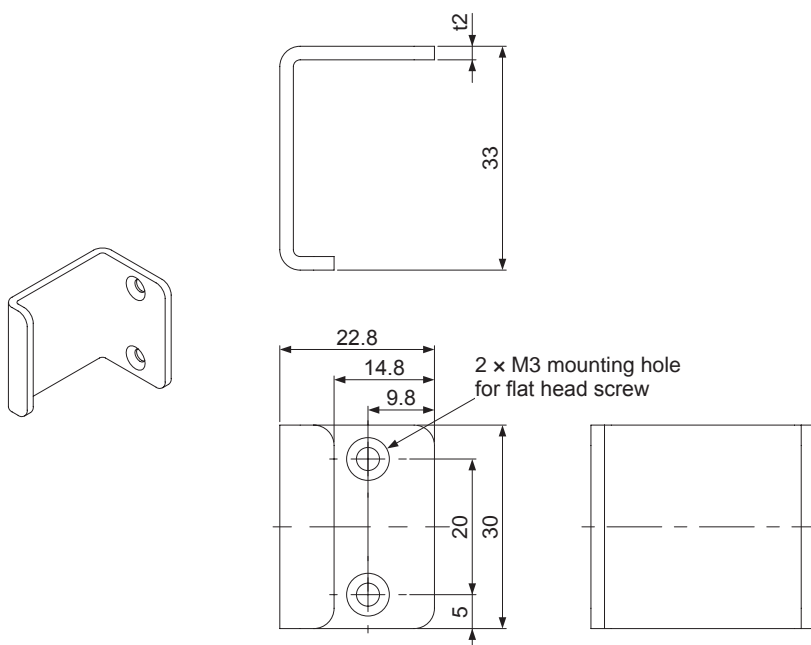

Material: Stainless steel

Dimensions

<Side mounting>

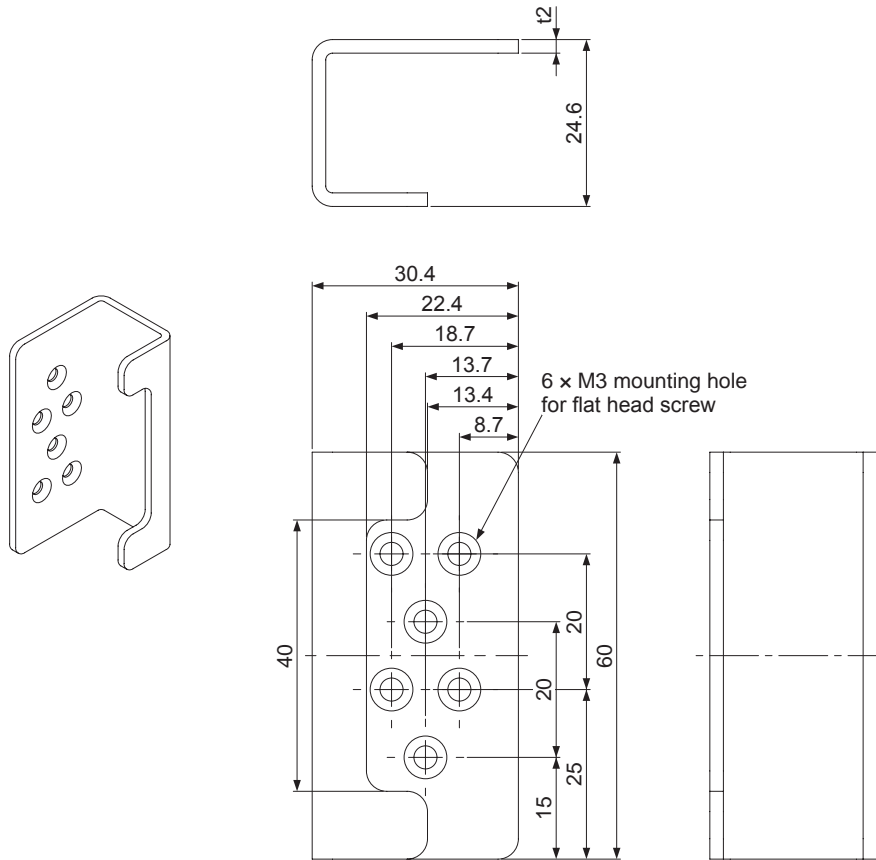

Material: Stainless steel

6) Side mounting bracket / MS-SF4BC-6

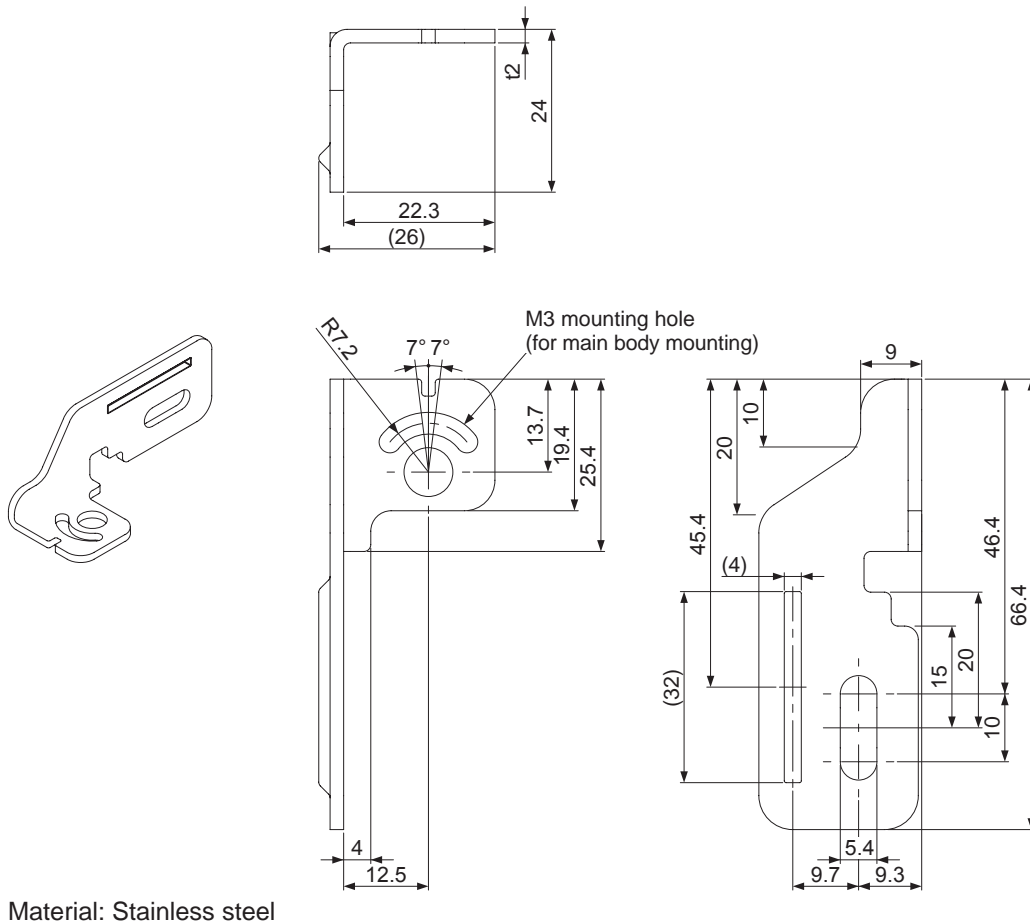

Material: Stainless steel

Dimensions

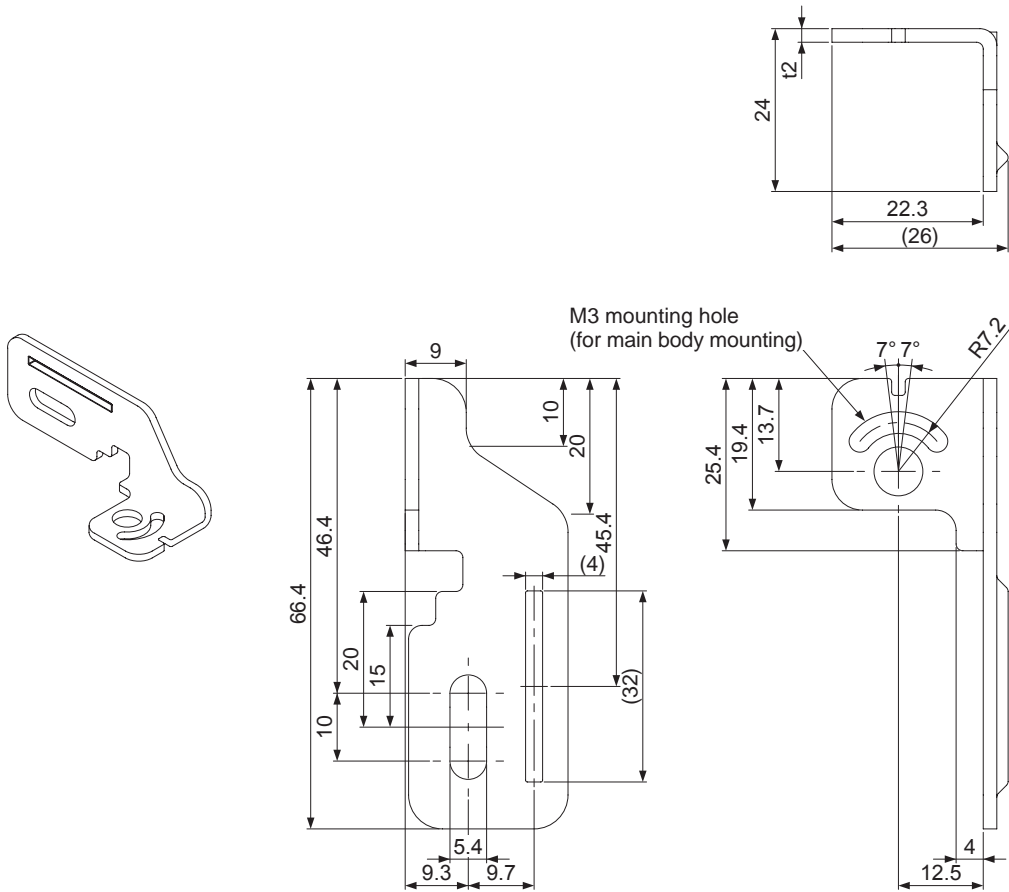

Material: Stainless steel

7) Intermediate supporting bracket for use with side mounting bracket / MS-SF4BC-7

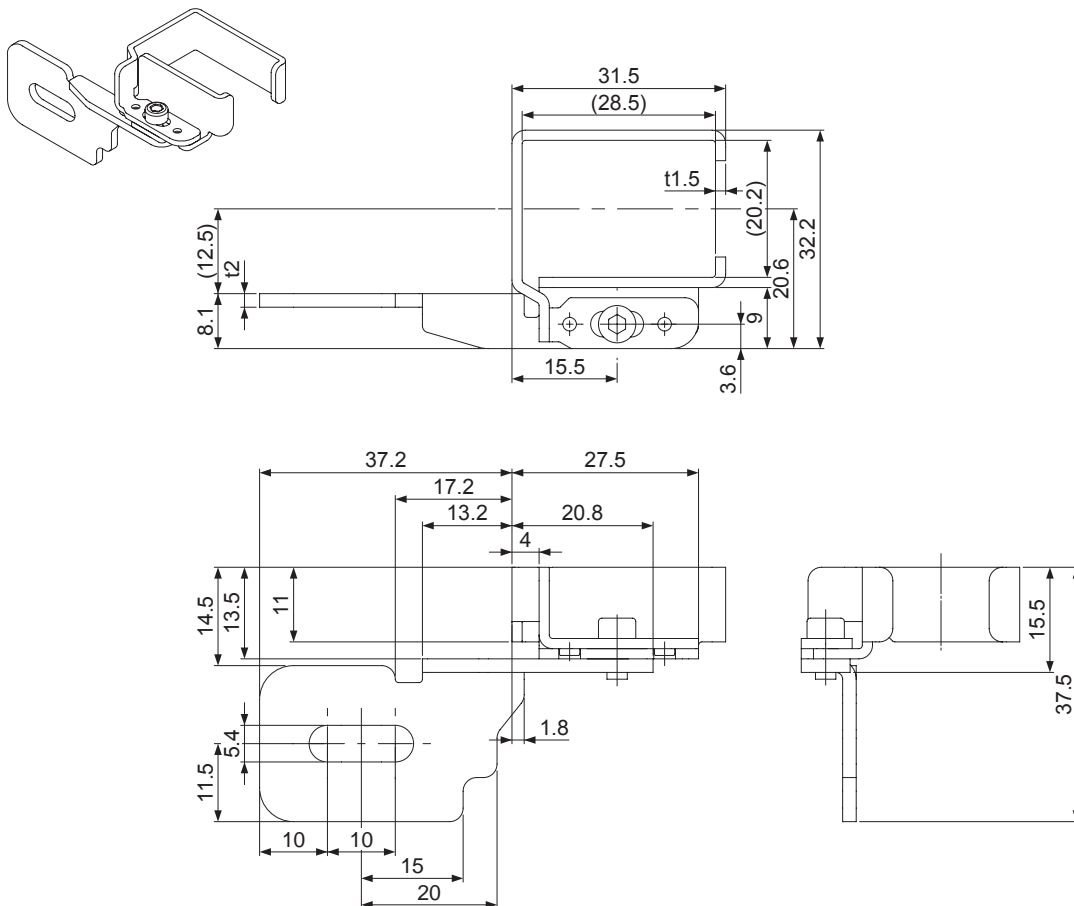

Material: Stainless steel

Dimensions

8) Protective metal case / MS-SF4BCH-□

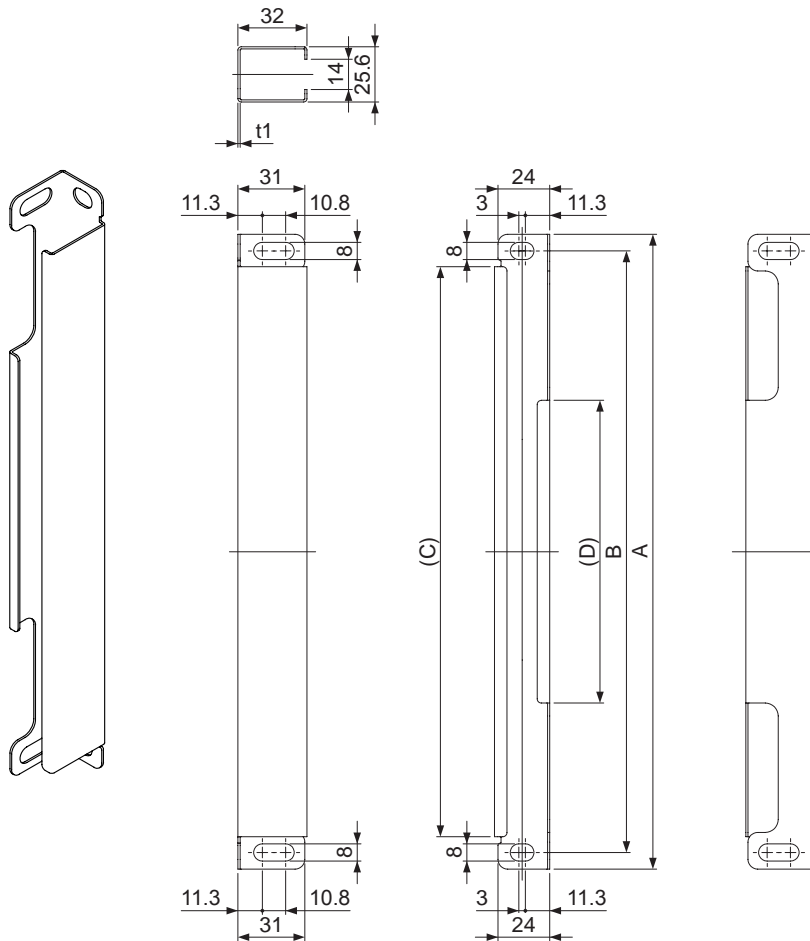

Material: Stainless steel

Model No.	A	B	C	D
MS-SF4BCH-12	294.4	279	264.4	140.4
MS-SF4BCH-16	374.4	359	344.4	220.4
MS-SF4BCH-20	454.4	439	424.4	300.4
MS-SF4BCH-24	534.4	519	504.4	380.4
MS-SF4BCH-28	614.4	599	584.4	460.4
MS-SF4BCH-32	694.4	679	664.4	540.4
MS-SF4BCH-36	774.4	759	744.4	620.4
MS-SF4BCH-40	854.4	839	824.4	700.4
MS-SF4BCH-48	1,014.4	999	984.4	860.4
MS-SF4BCH-56	1,174.4	1,159	1,144.4	1,020.4
MS-SF4BCH-64	1,334.4	1,319	1,304.4	1,180.4
MS-SF4BCH-72	1,494.4	1,479	1,464.4	1,340.4
MS-SF4BCH-80	1,654.4	1,639	1,624.4	1,500.4
MS-SF4BCH-88	1,814.4	1,799	1,784.4	1,660.4
MS-SF4BCH-96	1,974.4	1,959	1,944.4	1,820.4

7-1 Glossary

Machinery Directive	This directive is for an assembly of linked parts or components, energized by an electricity, compressed air or oil pressure, etc. and at least one of which moves, and a component which fulfills a safety function and is released into the market by itself.
EMC Directive	The directives is to any electric or electronic devices which will create more than a limited amount of RF interference, or will withstand a certain amount of Electro Magnetic fields while operating as intended within specifications.
EN 61496-1 IEC 61496-1/2 ANSI/UL 61496-1/2 JIS B 9704-1/2	The standards that pertain to machine safety, especially electro-sensitive protective equipment (ESPE). EN 61496-1, IEC 61496-1, ANSI/UL 61496-1 or JIS B 9704-1 gives general rules or failure mode and effect analysis, EMC requirements, etc. IEC 61496-2, ANSI/UL 61496-2 or JIS B 9704-2 specifies effective aperture angle, protection against extraneous light sources, etc, for Active Opto-electronic Protective Devices (AOPDs).
IEC 61508-1 to 7 JIS C 0508-1 to 7	The standards that pertain to general functional safety for electrical, electronic, and programmable electronic devices. These standards prescribe the methods, safety integrity levels (SIL) and other specifications that reduce the level of risk to a tolerable level of probability.
EN 55011	Specifies the limits and methods of measurement of radio disturbance characteristics of industrial, scientific and medical (ISM) radio-frequency equipment.
EN ISO 13849-1 ISO 13849-1 JIS B 9705-1	The standard that specifies the safety-related matters of machine safety / control system. They give roles for level (category) of structure and fault detection reliability, and for level of safety future performance capability (PL: Performance Level).
ESPE	The abbreviation for Electro-Sensitive Protective Equipment.
Control output (OSSD)	The abbreviation for Output Signal Switching Device. A component of the light curtain that turns OFF when light of the light curtain is blocked.
FSD	The abbreviation for Final Switching Device. The component of the machine's safety related control system that open-circuits the MPCE circuit when the OSSD operates due to the light from the light curtain being blocked.
Test rod	This is a rod for checking the detection capability of this device. It has dimensions corresponding to the minimum sensing object for this device.
Lockout	It is one of the safe status of this device. Operation is stopped if the self-diagnosis function determines that an irrecoverable failure (OSSDs do not operate normally, etc.) has occurred. If an emitter is in lockout condition, it will stop emitting light. If a receiver is in lockout condition, OSSDs are turned OFF.
Safety distance	It is the minimum distance that must be maintained between the light curtain and the dangerous parts of a machine so that the machine can be stopped before a human body or an object can reach the dangerous parts.

Others

Sensing height (Protective height)	The length of the beam-axis direction that the min. sensing object can be detected. The length from the center of the first beam channel to the center of the last beam channel in addition to +10mm (+5mm upward, +5mm downward).
Sensing range	It is the range between the facing emitter and receiver.
Sensing area	It is the area over which intrusion by people or objects can be detected by one set of the device. It is given by multiplying the sensing height (protective height) by the sensing range.
Emission halt input function	The function that checks operation by forcibly turning ON or OFF the control output (OSSD) for the receiver while light from the emitter is being received
PSDI	The abbreviation for the Presence Sensing Device Initiation. The safety device that restarts automatically without any operation by the operator after the device detects danger status and halts for a while.

7-2 CE Marking Declaration of Conformity

Itemized Essentials of EU Declaration of Conformity

Manufacturer's Name: Panasonic Industrial Devices SUNX Co., Ltd

Manufacturer's Address:

2431-1, Ushiyama-cho, Kasugai, Aichi 486-0901, Japan

EU Representative's Name:

Panasonic Marketing Europe GmbH Panasonic Testing Center

EU Representative's Address: Winsbergring 15, 22525 Hamburg, Germany

Product: Active Opto-electronic Protective Device (Light Curtain)

Model Name: SF4B Series

Trade Name: Panasonic

Application of Council Directive:

- 2006/42/EC Machinery Directive
- 2004/108/EC EMC Directive (Valid until April 19, 2016)
- 2014/30/EU EMC Directive (Valid from April 20, 2016)
- 2011/65/EU RoHS Directive

Harmonized standards:

- EN 61496-1: 2013
- EN ISO 13849-1: 2008
- EN 55011: 2009+A1: 2010
- EN 61000-6-2: 2005
- EN 50581: 2012

Type Examination: Certified by TÜV SÜD Product Service GmbH Ridlerstrasse
65 80339 München Germany

Revision History

First edition : May 22, 2013
Second edition : August 30, 2013
Third edition : November 15, 2013
Fourth edition : May 15, 2014
Fifth edition : June 30, 2014
Sixth edition : October 20, 2015
Seventh edition : January 15, 2016

1. WARRANTIES:

- (1) Subject to the exclusions stated in 2 (EXCLUSIONS) herein below, Panasonic Industrial Devices SUNX warrants the Products to be free of defects in material and workmanship for a period of one (1) year from the date of shipment under normal usage in environments commonly found in manufacturing industry.
- (2) Any Products found to be defective must be shipped to Panasonic Industrial Devices SUNX with all shipping costs paid by Purchaser or offered to Panasonic Industrial Devices SUNX for inspection and examination. Upon examination by Panasonic Industrial Devices SUNX, Panasonic Industrial Devices SUNX will, at its sole discretion, repair or replace at no charge, or refund the purchase price of, any Products found to be defective.

2. EXCLUSIONS:

- (1) This warranty does not apply to defects resulting from any cause:
 - (i) which was due to abuse, misuse, mishandling, improper installation, improper interfacing, or improper repair by Purchaser;
 - (ii) which was due to unauthorized modification by Purchaser, in part or in whole, whether in structure, performance or specification;
 - (iii) which was not discoverable by a person with the state-of-the-art scientific and technical knowledge at the time of manufacture;
 - (iv) which was due to an operation or use by Purchaser outside of the limits of operation or environment specified by Panasonic Industrial Devices SUNX;
 - (v) which was due to normal wear and tear;
 - (vi) which was due to Force Majeure; and
 - (vii) which was due to any use or application expressly discouraged by Panasonic Industrial Devices SUNX in 4 (CAUTIONS FOR SAFE USE) hereunder.
- (2) This warranty extends only to the first purchaser for application, and is not transferable to any person or entity which purchased from such purchaser for application.

3. DISCLAIMERS

- (1) Panasonic Industrial Devices SUNX's sole obligation and liability under this warranty is limited to the repair or replacement, or refund of the purchase price, of a defective Product, at Panasonic Industrial Devices SUNX's option.
- (2) THE REPAIR, REPLACEMENT, OR REFUND IS THE EXCLUSIVE REMEDY OF THE PURCHASER, AND ALL OTHER WARRANTIES, EXPRESS OR IMPLIED, INCLUDING, WITHOUT LIMITATION, THE WARRANTIES OF MERCHANTABILITY, FITNESS FOR A PARTICULAR PURPOSE, AND NON-INFRINGEMENT OF PROPRIETARY RIGHTS, ARE HEREBY EXPRESSLY DISCLAIMED. IN NO EVENT SHALL PANASONIC INDUSTRIAL DEVICES SUNX AND ITS AFFILIATED ENTITIES BE LIABLE FOR DAMAGES IN EXCESS OF THE PURCHASE PRICE OF THE PRODUCTS, OR FOR ANY INDIRECT, INCIDENTAL, SPECIAL OR CONSEQUENTIAL DAMAGES OF ANY KIND, GENERAL TERMS AND CONDITIONS 4 OR ANY DAMAGES RESULTING FROM LOSS OF USE, BUSINESS INTERRUPTION, LOSS OF INFORMATION, LOSS OR INACCURACY OF DATA, LOSS OF PROFITS, LOSS OF SAVINGS, THE COST OF PROCUREMENT OF SUBSTITUTED GOODS, SERVICES OR TECHNOLOGIES, OR FOR ANY MATTER ARISING OUT OF OR IN CONNECTION WITH THE USE OR INABILITY TO USE THE PRODUCTS.

4. CAUTIONS FOR SAFE USE

- (1) The applications shown in the catalogue are only suggestions, and it is Purchaser's sole responsibility to ascertain the fitness and suitability of the Products for any particular application, as well as to abide by Purchaser's applicable local laws and regulations, if any.
- (2) Never use the Products NOT rated or designated as "SAFETY SENSOR" in any application involving risk to life or property. When such a use is made by Purchaser, such Purchaser shall indemnify and hold harmless Panasonic Industrial Devices SUNX from any liability or damage whatsoever arising out of or in relation to such use.
- (3) In incorporating the Products to any equipment, facilities or systems, it is highly recommended to employ fail-safe designs, including but not limited to a redundant +++design, flame propagation prevention design, and malfunction prevention design so as not to cause any risk of bodily injury, fire accident, or social damage due to any failure of such equipment, facilities or systems.
- (4) The Products are each intended for use only in environments commonly found in manufacturing industry, and, unless expressly allowed in the catalogue, specification or otherwise, shall not be used in, or incorporated into, any equipment, facilities or systems, such as those:
 - (a) which are used for the protection of human life or body parts;
 - (b) which are used outdoors or in environments subject to any likelihood of chemical contamination or electromagnetic influence;
 - (c) which are likely to be used beyond the limits of operations or environments specified by Panasonic Industrial Devices SUNX in the catalogue or otherwise;
 - (d) which may cause risk to life or property, such as nuclear energy control equipment, transportation equipment (whether on rail or land, or in air or at sea), and medical equipment;
 - (e) which are operated continuously each day for 24 hours; and
 - (f) which otherwise require a high level of safety performance similar to that required in those equipment, facilities or systems as listed in (a) through (e) above.

5. EXPORT CONTROL LAWS

In some jurisdictions, the Products may be subject to local export laws and regulations. If any diversion or re-export is to be made, Purchaser is advised to abide by such local export laws and regulations, if any, at its own responsibility.