

Panasonic

NEW

Contact-Type
Digital Displacement Sensor

HG-S SERIES

CE
Conforming to
EMC Directive

Slim & Robust Sensor Unit

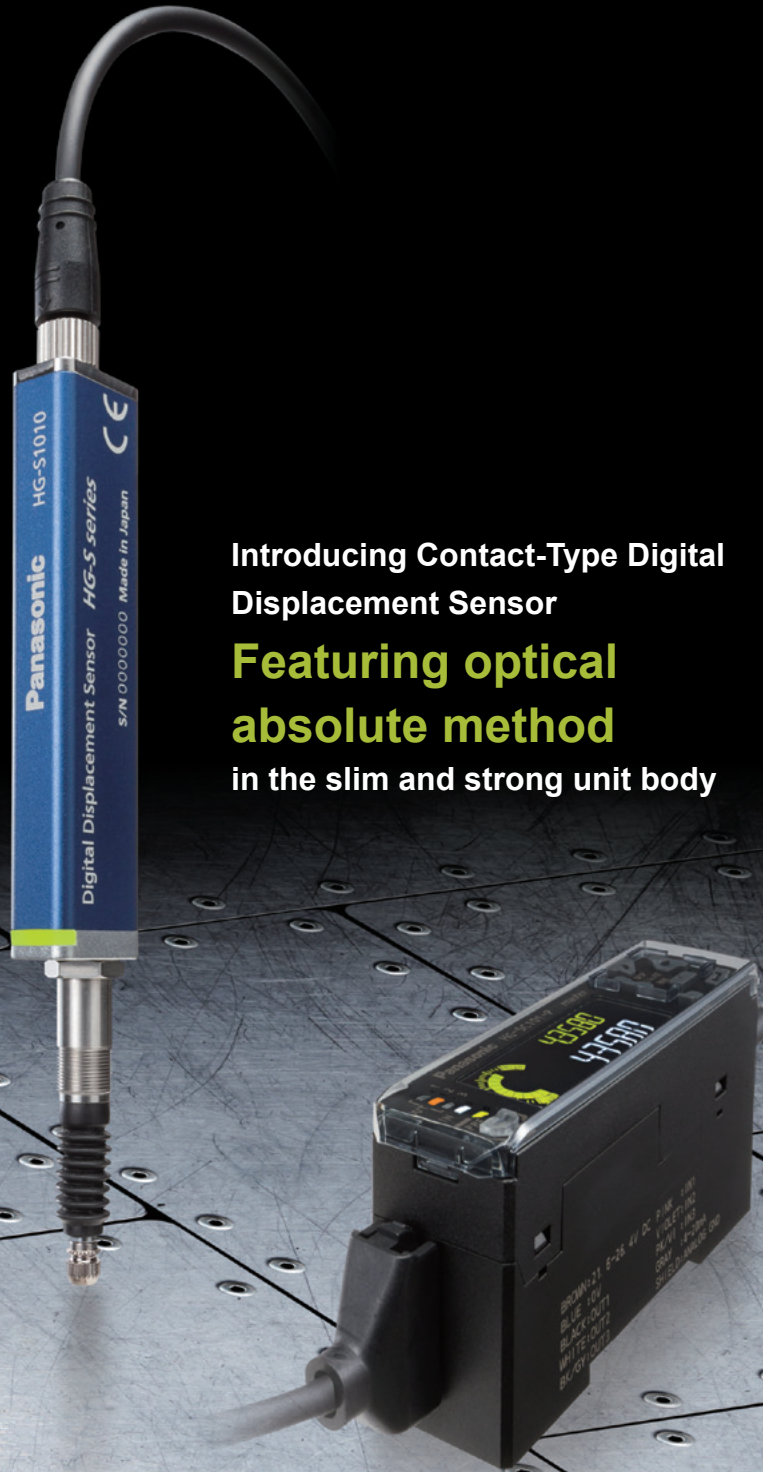

Introducing Contact-Type Digital
Displacement Sensor

**Featuring optical
absolute method**

in the slim and strong unit body

Contact-type digital displacement sensor using optical absolute method developed to meet

New contact-type digital displacement sensor developed to meet the needs of production floor.

The high-precision slim sensor unit features a robust sensor head, while the controller offers a diversity of functions.

> Sensor head

Development target:

Slim & Robust

- Slim body measuring 11 × 18 × 84.5 mm **0.433 × 0.709 × 3.327 in** for easy installation even in a side-by-side arrangement.
- Class-top robustness in the industry

Lateral load
resistance
No. 1* in class

Vibration / impact
resistance
No. 1* in class

* As of September 2015, according to our survey.



> Optical absolute method

Development goal:

Highest Accuracy in Class

Resolution
No. 1* in class

Indication
accuracy
No. 1* in class

* As of September 2015, according to our survey.

- Resolution of 0.1 μm **0.004 mil** and indication accuracy of 1 μm **0.039 mil** or less
- Absolute value scale reading for elimination of “value skipping” and “unset zero”

> Controller

Development focus:

Intuitive Dual Display

- 2-line digital display for unprecedented ease of use
- Full-fledged functions designed for optimum ease of operation on production floor

Industry's
first*

* As of September 2015, according to our survey.



Sensor head

Advanced technologies and unparalleled craftsmanship made the contact-type digital displacement sensor so slim and strong!

The slim unit body contains plain bearings with 2-point support structure disperses load and achieves superb durability. The sensor head offers long life and reduces maintenance costs dramatically.

Slim & robust

As slim as a pencil-type sensor unit!

Hot-swappable

Bending-resistant cable

Cable is highly resistant to wire breakage even when used for moving parts.

Plain bearings with 2-point support structure

Ball-less bearings are installed at the upper and lower sections of the unit. This ensures excellent strength against lateral loads.

Durability to withstand more than 100 million sliding operations (typical value)

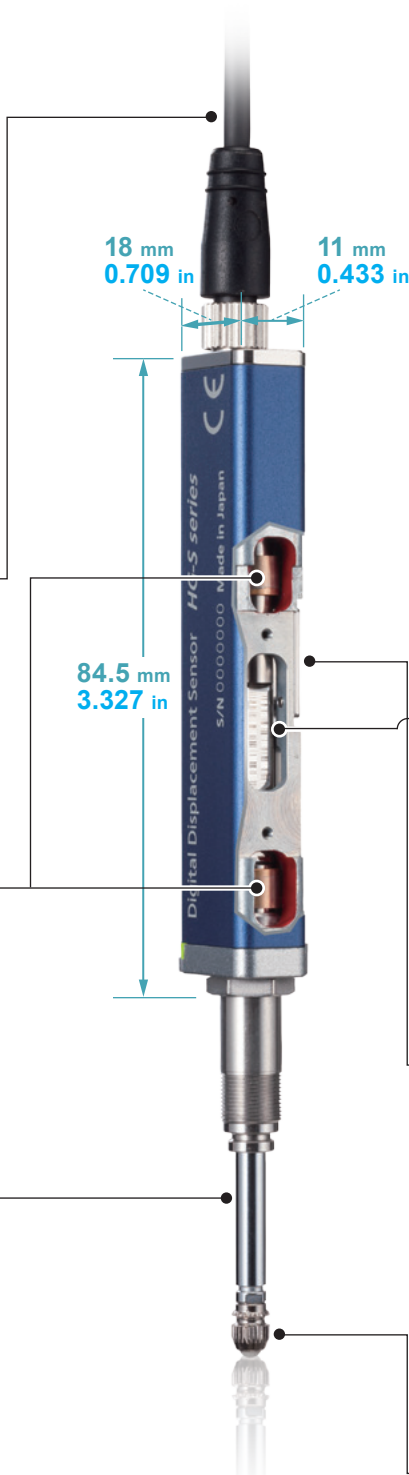

Class-top accuracy

Optical absolute method eliminates "value skipping." (equipped with high-resolution CMOS)

The high-resolution CMOS sensors read the glass scales that have different slit patterns at different read positions to measure the amount of movement. This provides accurate measurements without "value skipping" even in highspeed measuring operations. It also eliminates "unset zero point."

Class-top accuracy

High-precision sensor head	
Resolution 0.1 μm 0.004 mil	Indication accuracy Full range: 1 μm 0.039 mil or less Narrow range: 0.5 μm 0.020 mil or less

Resolution
No. 1* in class

Indication accuracy
No. 1* in class

* As of September 2015, according to our survey.

Metal guide rotation stopper structure



Tip deviation amount of 0.5 μm 0.020 mil or less

Superb craftsmanship!

The accuracy and robustness of the **HG-S** series are backed by master craftsmanship. The plain bearings are accurately aligned with the center of the spindle during their installation to the top and bottom sections of the body to ensure smooth sliding. This process involves careful adjustment of each bearing by a skilled worker. Even though the plain bearing has a certain width, the clearance is managed to the accuracy of several μm . Those with experience in mechanisms design will know that this value signifies amazingly high control precision.

The high-precision, robust sensor is made possible by master craftsmanship. Maximize the high accuracy of our sensors in your pursuit of "ever higher levels of quality."

Resistance to lateral load

Withstands more than 100 million sliding operations under application of lateral load (reference value)

Lateral load resistance
No. 1* in class

* As of September 2015, according to our survey.

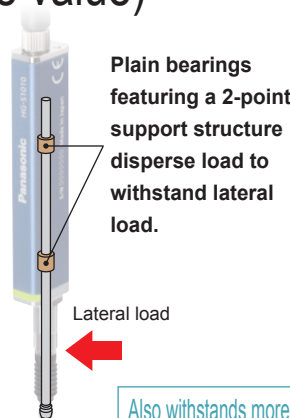
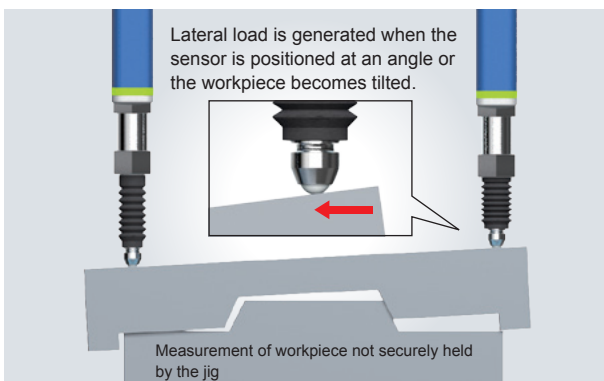

Lateral load resistance test (note 1)
Withstands 100 million sliding operations (reference value)

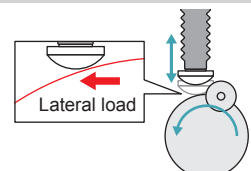

(Note 1): Button-type probe for evaluation purposes was installed on the test sample for the lateral load resistance test.

Also withstands more than 100 million vertical sliding operations.

Resistant to upward thrust impact

Spindle stopper installed at the lower section

Vibration/impact resistance
No. 1* in class

* As of September 2015, according to our survey.

Even when a sudden upward thrust impact occurs, the resulting load is applied only to the lower section of the sensor unit. This structure minimizes adverse effect of impact on the glass scales.

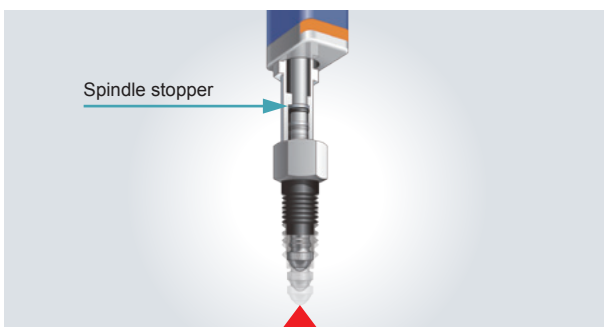

Hot-swappable

Change of sensor head without turning off the power supply

The sensor head can be changed safely without turning off the controller. This reduces the man-hours required for the change of line setup for processing of different workpieces, thus achieving a significant reduction of setup change time.



Controller

Versatile and Easy-to-Use Controller

The controller features the industry's first* dual display and offers versatile functions and excellent ease of use.

It allows simple and reliable operation of the advanced measurement function in a diversity of applications.

Industry's first!*

* As a sensor product using optical absolute method, as of September 2015 (according to our company's investigation)

Dual display for added indication flexibility (equipped with NAVI function)

The 2-line digital display simultaneously shows head measurement (measured value) and judgment value (calculated value).

All-direction LCD

The high-contrast LCD provides sharp and clear indications and wide viewing angle.

Equipped with intuitive circle meter

Values between allowable maximum and minimum values are indicated in green. Values outside of the allowable range are indicated in orange. This provides at-a-glance understanding of the margin to the tolerance limits.



Higher than maximum value

Lower than minimum value

Anytime selection of function to copy

The selective copy function significantly reduces the man-hours required for initial setting and maintenance.



High-speed response of 3 ms in combination with any sensor head

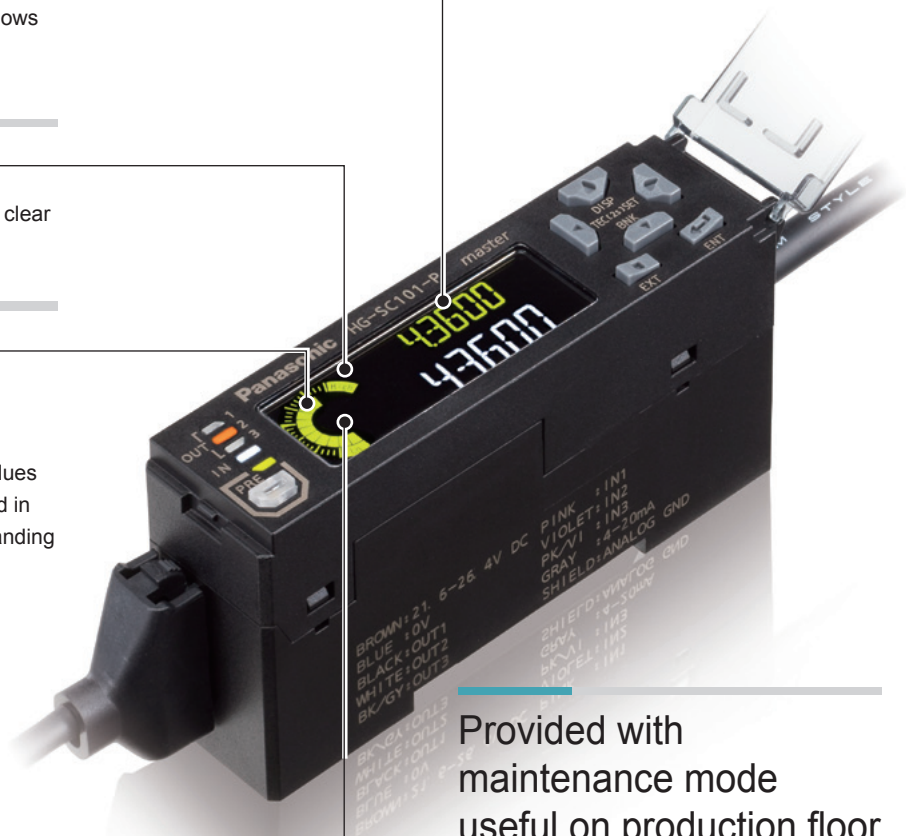

Provided with maintenance mode useful on production floor

The following data are stored and can be used for analysis on the spot.

- Abnormal sensor head upward thrust value
- Number of sensor head upward thrusts
- Cumulative total number of sliding operations

Alarm setting for notification of upward thrust

Alarm can be set to notify an upward thrust (stroke) that exceeds the set level. This allows you to conduct a preventive maintenance before the sensor head

Easy-to-understand 2-line digital display

The 2-line digital display simultaneously shows sensor head measurement and judgment value.



Easy tolerance setting

Simple 1-point teaching

Align with master workpiece and press ENTER key for easy tolerance setting.

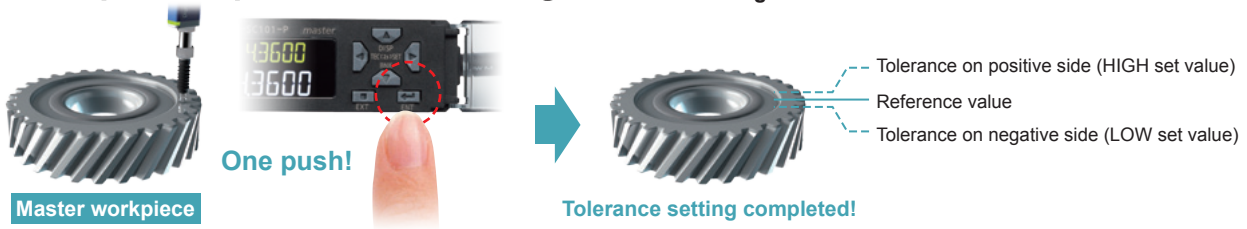

No need for trigger input

Equipped with self-trigger hold function

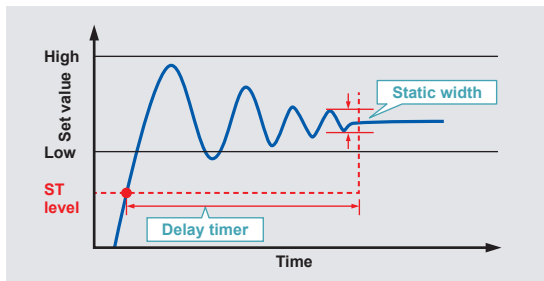

Easy setting of time length from measurement start to measurement stabilization.

Minimizes measurement fluctuation due to the vibration caused by stopping of spindle rotation.

(1) Static width setting

Stability range above the ST level can be set as desired. Set the range where measurements are considered to be stable.

(2) Delay timer setting

Desired delay time after measurement exceeding the ST level can be set. Set the time required for stabilization of measurement.

Lateral connection of slave units for added operational ease

Connection of up to 15 slave units

(Example: Connection of 15 slave units)

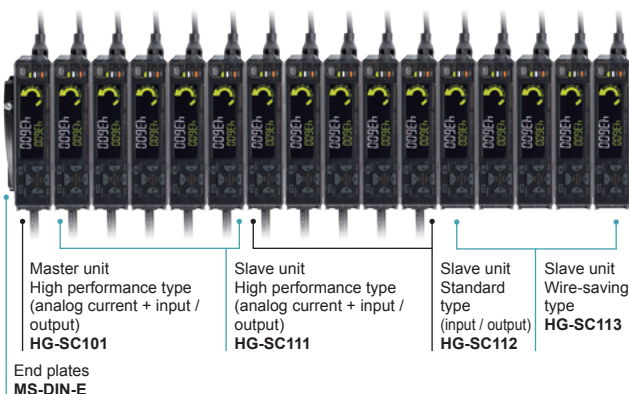

*End plates (optional) must be mounted on both sides of the controller after the connection of slave units.

One master unit can be connected with up to 15 slave units in any order. This allows easy multi-point calculations.

Controller variations

- Master unit (1 model)
 - High performance type (analog current + input / output)
- Slave unit (3 models)
 - High performance type (analog current + input / output)
 - Standard type (input / output)
 - Wire-saving type

Hold function (9 types)

Sample hold (S-H)	Peak hold (P-H)	Bottom hold (B-H)
Peak-to-peak hold (P-P)	Peak-to-peak hold/2 (P-P/2)	
NG hold (NG-H)	Self-sample hold (SLF.S-H)	
Self-peak hold (SLF.P-H)	Self-bottom hold (SLF.B-H)	

Calculation function (8 types)

MAX (maximum value)	MIN (minimum value)	FLAT (flatness)
AVERAG (average value)	STAND (reference difference)	
TORSIN (torsion)	CURVEA (curvature)	THICK (thickness)

Automotive applications

1
Automotive application



Coupling assembly inspection

2
Automotive application



Installed height measurement

3
Automotive application

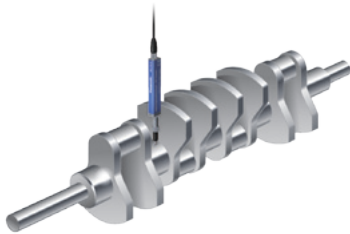

Crankshaft dimension measurement

4
Automotive application



Screw head height measurement

5
Automotive application



Transmission parts height measurement

6
Automotive application



Automotive parts dimension measurement

7
Automotive application

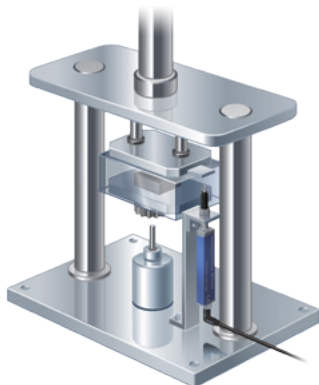

Contact-type displacement sensor and load cell are used to manage pressure change point and stroke position for the confirmation of proper press-fit mounting.

Management of press-fit points of press-fit parts

Other applications

1
Other application



Motor shaft eccentricity measurement

2
Other application

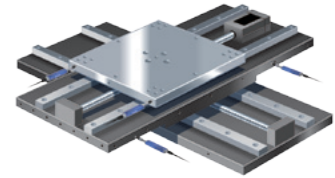

X-Y stage position measurement

3
Other application



Tablet surface flatness measurement

4
Other application



Resin roller eccentricity measurement

Products

Sensor head

General purpose

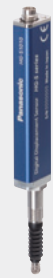

Resolution: 0.5 μm **0.020 mil**
 Measurement range: 10 mm **0.394 in**

- Standard type **HG-S1010**
- Low measuring force type **HG-S1010R**

High precision

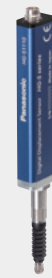

Resolution: 0.1 μm **0.004 mil**
 Measurement range: 10 mm **0.394 in**

- Standard type **HG-S1110**
- Low measuring force type **HG-S1110R**

Sensor head connection cable (bending-resistant type)

Straight connector



Length: 3 m **9.843 ft** **CN-HS-C3**
 Length: 7 m **22.966 ft** **CN-HS-C7**
 Length: 20 m **65.617 ft** **CN-HS-C20**

L-shaped connector



Length: 3 m **9.843 ft** **CN-HS-C3L**
 Length: 7 m **22.966 ft** **CN-HS-C7L**
 Length: 20 m **65.617 ft** **CN-HS-C20L**

Controller

Master unit



- High performance type (analog current + input / output)
 NPN output type **HG-SC101**
 PNP output type **HG-SC101-P**

Up to 15 slave units can be connected per master unit.

Slave units



- High performance type (analog current + input / output)
 NPN output type **HG-SC111**
 PNP output type **HG-SC111-P**

- Standard type (input / output)
 NPN output type **HG-SC112**
 PNP output type **HG-SC112-P**

Slave units



- Wire-saving type **HG-SC113**

Controller end plate



End plates are required for connection of controllers.

MS-DIN-E

2 pcs. per set

Options (made-to-order)

Probe



Standard type **TR-S10-C \times 5**
 5 pcs. per set



Super-hard type **TR-S10-H**



Super-hard needle type **TR-S321-H**



Flat-seated type **TR-S411-K**



Roller type **TR-S601**



Offset type **TR-S700-H**

Joint



Length 15 mm **0.591 in** type **TR-J102**



Length 25 mm **0.984 in** type **TR-J104**

Rubber bellows



TR-G20 \times 5
 5 pcs. per set

Sensor head

Type		General purpose		High precision	
		Standard type	Low measuring force type	Standard type	Low measuring force type
Item	Model No.	HG-S1010	HG-S1010R	HG-S1110	HG-S1110R
Compatible controller		HG-SC101(-P), HG-SC111(-P), HG-SC112(-P), HG-SC113			
Position detection method		Optical absolute linear encoder method			
Measurement range		10 mm 0.394 in (Note 1)			
Stroke		10.5 mm 0.413 in or more (Note 1)			
Measuring force (Note 2) (Note 3)	Downward mount	1.65 N or less 1.1 N (Note 4)	0.35 N or less 0.3 N (Note 4)	1.65 N or less 1.1 N (Note 4)	0.35 N or less 0.3 N (Note 4)
	Upward mount	1.35 N or less 0.85 N (Note 4)	0.12 N or less 0.05 N (Note 4)	1.35 N or less 0.85 N (Note 4)	0.12 N or less 0.05 N (Note 4)
	Side mount	1.5 N or less 0.95 N (Note 4)	0.25 N or less 0.2 N (Note 4)	1.5 N or less 0.95 N (Note 4)	0.25 N or less 0.2 N (Note 4)
Resolution		0.5 µm 0.020 mil		0.1 µm 0.004 mil	
Indication accuracy (P-P) (Note 2)		Full range: 2.0 µm 0.079 mil or less Narrow range: 1.0 µm 0.039 mil or less (any 60 µm 2.362 mil)		Full range: 1.0 µm 0.039 mil or less Narrow range: 0.5 µm 0.020 mil or less (any 60 µm 2.362 mil)	
Tip deviation amount		35 µm 1.378 mil (typical)			
Hot swap function		Incorporated			
Operation indicator		2-color LED (Orange / Green)			
Environmental resistance	Protective structure	IP67 (IEC) (Note 5)	————	IP67 (IEC) (Note 5)	————
	Ambient temperature	-10 to +55 °C +14 to +131 °F (No condensation or icing), Storage: -20 to +60 °C -4 to +140 °F			
	Ambient humidity	35 to 85 % RH, Storage: 35 to 85 % RH			
	Insulation resistance	100 MΩ or more at 250 V DC			
	Vibration resistance	10 to 500 Hz frequency, 3 mm 0.118 in double amplitude (maximum acceleration 196 m/s ²) in X, Y and Z directions for two hours each			
	Shock resistance	1,960 m/s ² acceleration in X, Y and Z directions three times each			
Mechanical life		100 million times or more (Note 6)			
Tightening torque		Setscrew: 1.5 N·m, nut: 12.5 N·m			
Probe tightening torque		0.1 to 0.4 N·m (no force applied to main unit)			
Grounding method		Capacitor grounding			
Material		Body: Zinc, Holder: Stainless steel, Spindle: Tool steel, Probe (Note 7): Ceramic, Rubber bellows: NBR (black)			
Weight		Main unit weight: 80 g approx.			
Accessory		Standard type (HG-S1010 / HG-S1110): Sensor head fastening wrench 1 pc., mounting nut 1 pc. Low measuring force type (HG-S1010R / HG-S1110R): Sensor head fastening wrench 1 pc., mounting nut 1 pc., rubber bellows 1 pc.			

Notes: 1) 5 to 10 mm 0.197 to 0.394 in range when low measurement force type (HG-S1010R / HG-S1110R) is mounted in upward mount.

2) Measured at an ambient temperature of +20 °C +68 °F.

3) In the case of low measurement force type (HG-S1010R / HG-S1110R), measurements were obtained with products in standard configuration without rubber bellows.

4) Typical value near center of measurement.

5) Excludes damage and deterioration to rubber bellows due to external causes.

6) Typical value in a clean environment with no contact with dust or liquids such as water and oil.

Four million times (typical) when low measurement force type (HG-S1010R / HG-S1110R) is mounted in upward mount.

7) The probes (optional) are also available.

SPECIFICATIONS

Controller

Item	Model No.	Type	Master unit		Slave unit	
			High-performance type	High-performance type	Standard type	Wire-saving type
			NPN output	HG-SC101	HG-SC111	HG-SC112
PNP output	HG-SC101-P	HG-SC111-P	HG-SC112-P			
Compatible sensor head			HG-S1010(R), HG-S1110(R)			
Number of connectable units			Up to 15 slave units can be connected per master unit.			
Supply voltage			24 V DC ±10 %, including ripple 0.5 V (P-P)			
Current consumption (Note 2)			70 mA or less (when sensor head is connected)			
Analog current output (Note 3)			<ul style="list-style-type: none"> • Current output range: 4 to 20 mA / F.S. (default value) • Error output: 0 mA • Linearity: ±0.25 % F.S. • Load impedance: 250 Ω max. 			
Control output (Output 1, Output 2, Output 3)			<p><NPN output type></p> <ul style="list-style-type: none"> • NPN open-collector transistor • Maximum sink current: 50 mA (Note 4) • Applied voltage: 30 V DC or less (between output and 0 V) • Residual voltage: 1.5 V or less (at 50 mA sink current) • Leakage current: 0.1 mA or less 	<p><PNP output type></p> <ul style="list-style-type: none"> • PNP open-collector transistor • Maximum source current: 50 mA (Note 4) • Applied voltage: 30 V DC or less (between output and +V) • Residual voltage: 1.5 V or less (at 50 mA source current) • Leakage current: 0.1 mA or less 		
Short-circuit protection			Incorporated (automatic reset type)			
Judgment output			NO / NC switching method			
Alarm output			Open when alarm occurs			
External input (Input 1, Input 2, Input 3)			<p><NPN output type></p> <ul style="list-style-type: none"> • Non-contact input or NPN open-collector transistor • Input condition: Invalid (+8 V to +V DC or open) Valid (0 to +1.2 V DC) • Input impedance: 10 kΩ approx. 	<p><PNP output type></p> <ul style="list-style-type: none"> • Non-contact input or PNP open-collector transistor • Input condition: Invalid (0 to +0.6 V DC or open) Valid (+4 V to +V DC) • Input impedance: 10 kΩ approx. 		
Trigger input			Input time 2 ms or more (ON)			
Preset input			Input time 20 ms or more (ON)			
Reset input			Input time 20 ms or more (ON)			
Bank input A / B			Input time 20 ms or more (ON)			
Response time			3 ms, 5 ms, 10 ms, 100 ms, 500 ms, 1,000 ms switching type			
Digital display			204-segment LCD			
Display resolution			0.1 μm 0.004 mil			
Display range			-199.9999 to 199.9999 mm -7.874 to 7.874 in			
Contamination level			2			
Elevation			2000 m 6561.68 ft or less			
Environmental resistance	Protective structure		IP40 (IEC)			
	Ambient temperature		-10 to +50 °C +14 to +122 °F (No condensation or icing), Storage: -20 to +60 °C -4 to +140 °F			
	Ambient humidity		35 to 85 % RH, Storage: 35 to 85 % RH			
	Insulation resistance		20 MΩ, or more, with 250 V DC megger between all supply terminals connected together and enclosure			
	Withstand voltage		1,000 V AC for one min. between all supply terminals connected together and enclosure			
	Vibration resistance		10 to 150 Hz frequency, 0.75 mm 0.030 in amplitude in X, Y and Z directions for two hours each			
	Shock resistance		98 m/s ² acceleration (10 G approx.) in X, Y and Z directions five times each			
Material			Case: Polycarbonate, Cover: Polycarbonate, Switches: Polyacetal			
Cable			0.2 mm ² 2-core cable (brown and blue lead wires) / 0.15 mm ² 7-core composite cable, 2 m 6.562 ft long	0.15 mm ² , 7-core composite cable, 2 m 6.562 ft long	0.15 mm ² , 6-core cable type cable, 2 m 6.562 ft long	
Weight			Main unit weight: 140 g approx.	Main unit weight: 140 g approx.	Main unit weight: 130 g approx.	Main unit weight: 60 g approx.

Notes: 1) Where measurement conditions have not been specified precisely, the conditions used were as follows: supply voltage 24 V DC, ambient temperature +20 °C +68 °F.

2) Current consumption does not include analog current output.

3) Linearity F.S. = 16 mA, and is linearity with respect to digitally measured values.

4) When slave units are connected to the master unit, the maximum sink current / source current of the control output and ambient temperature vary depending on the number of connected slave units as shown below.

Number of connected slave units	Maximum sink current / source current of control output	Ambient temperature
1 to 7 units	20 mA	-10 to +45 °C +14 to +113 °F
8 to 15 units	10 mA	

NPN output type

HG-SC101 / Master unit

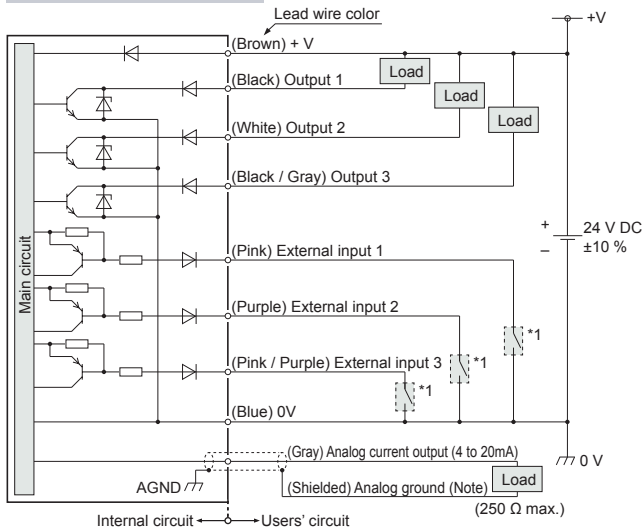

PNP output type

HG-SC101-P / Master unit

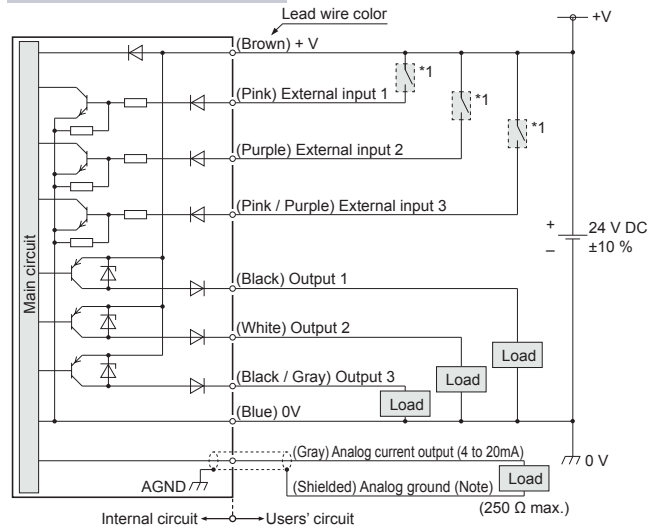

HG-SC111 / Slave unit

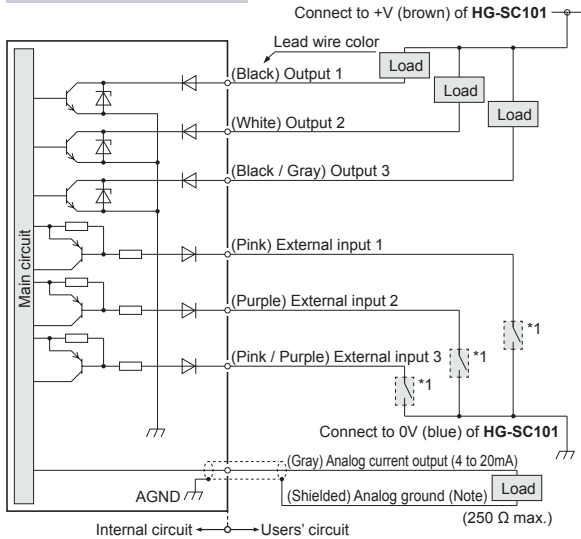

HG-SC111-P / Slave unit

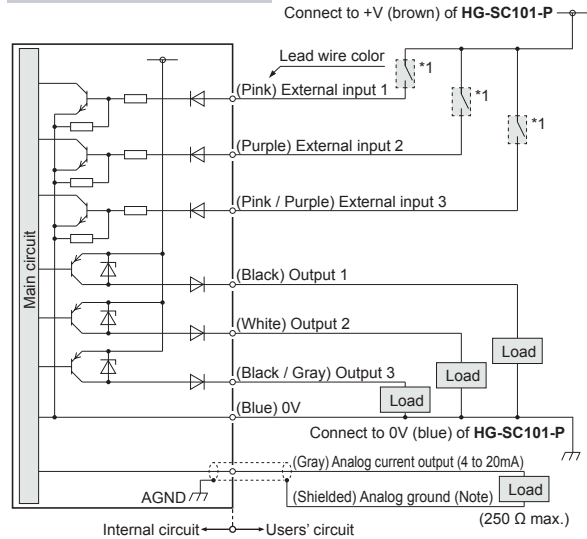

HG-SC112 / Slave unit

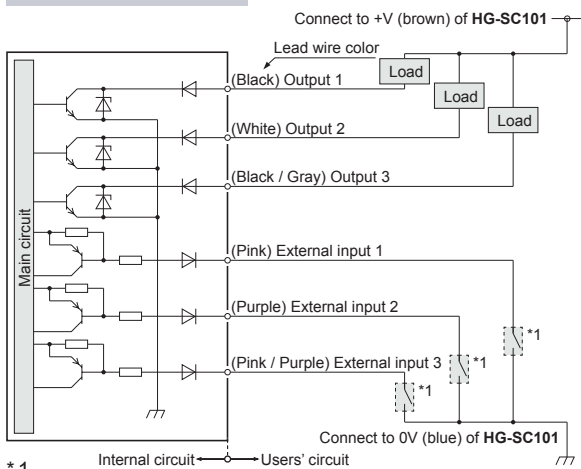

HG-SC112-P / Slave unit

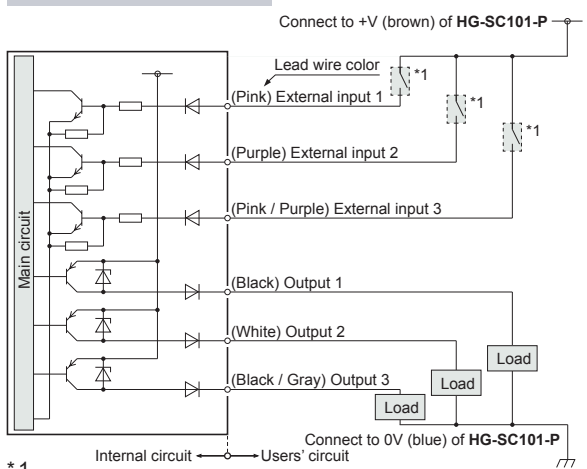

Non-voltage contact or NPN open collector transistor

0 to +1.2 V DC: Effective
+8 V to +V DC or open: Ineffective

Non-voltage contact or PNP open collector transistor

+4 V to +V DC: Effective
0 to +0.6 V DC or open: Ineffective

PRECAUTIONS FOR PROPER USE

For details, refer to the User's Manual.
The User's Manual can be downloaded from our website.



- Never use this product as a sensing device for personnel protection.
- When using sensing devices for personnel protection, use products that meet the laws and standards for personnel protection that apply in each region or country, such as OSHA, ANSI and IEC.

- This catalog has been prepared to aid selection of appropriate products. When using the product, be sure to read the User's Manual.

Part description

Sensor head

<Standard type> (HG-S1010 / HG-S1110)

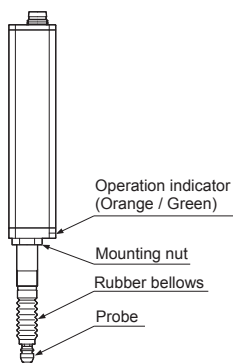
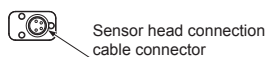

<Low measuring force type> (HG-S1010R / HG-S1110R)

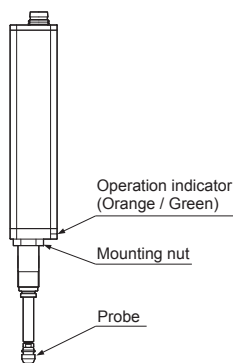
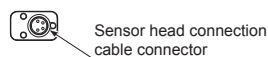

Controller

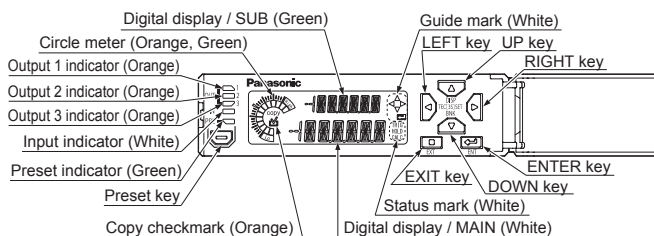
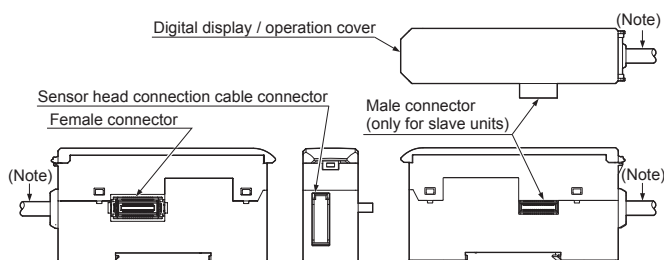

Note: Not provided on slave units or wire-saving type (HG-SC113).

Sensor head

Mounting

- When tightening the nut, take care not to damage the rubber bellows.
- If the rubber bellows is deformed, a load will occur when the spindle operates and damage may result.
- Do not remove the rubber bellows from the standard type products (HG-S1010 / HG-S1110) except for when replacing them. Unnecessary removal of rubber bellows can result in entry of dust and water, thus causing malfunction.

1. Open a hole in the housing in which the sensor head will be mounted.

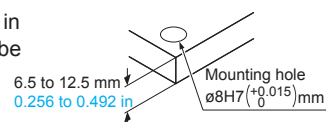

2. Insert the sensor head into the hole you opened in the housing, and fasten provisionally with the provided mounting nut.

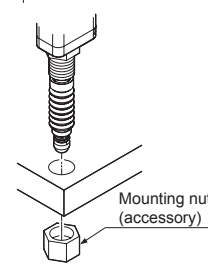

3. Fasten the sensor head. When fastening the sensor head, tighten the mounting nut with a wrench while holding the sensor head in place with the provided sensor head fastening wrench as shown right. Tighten to a torque of 12.5 N·m or less.

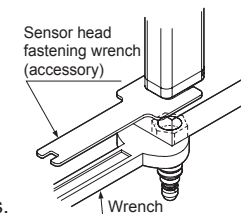

4. Make sure that the rubber bellows has not become deformed as shown right. If the rubber bellows is deformed, restore the normal shape by rotating the bellows or otherwise.

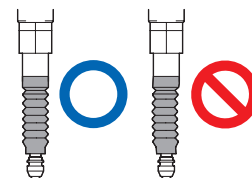

Attaching the sensor head connection cable

- When disconnecting, always make sure that the fastening ring has been completely loosened before pulling out the cable.
- Risk of damage if you pull the cable with excessive force (15 N or more) with the fastening ring tightened.

Mounting

1. Insert the sensor head connection cable into the connector for the sensor head connection cable on the sensor head.
2. Turn the fastening ring on the sensor head connector in the direction shown to fasten the ring.

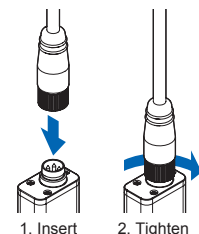

Removal method

1. Turn the fastening ring on the sensor head connector in the direction of the arrow to loosen the ring.
2. Grasp the sensor head connector and pull up to remove.

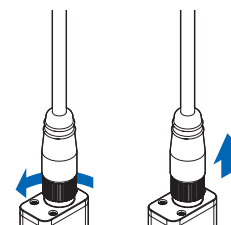

Controller

Mounting

Mounting

1. Insert the rear of the mounting part into the DIN rail.
2. While pressing down on the rear of the mounting part, insert the front of the mounting part into the DIN rail.

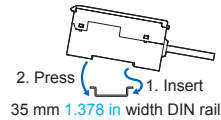

Removal method

1. Grasp the product and push forward.
2. Lift the front to remove.

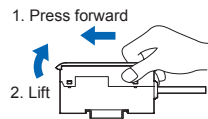

Attaching the sensor head connection cable

Mounting

1. Insert the sensor head connection cable into the connector for the sensor head connection cable on the controller.

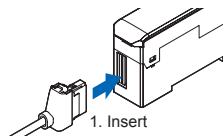

Removal method

1. Grasp the controller, and while pressing on the lock release lever on the connector of the sensor head connection cable, pull toward you to disconnect.

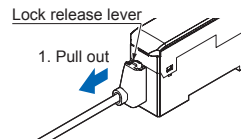

Note: If you attempt to disconnect the cable by pulling it without pressing the lock release lever, cable wire breakage and connector damage may occur.

Connection

- Always shut off the power before connecting a slave unit to or disconnecting a slave unit from the master unit. Risk of controller damage if you attempt connection with the power on.
- Insert the male connector firmly into the female connector. Risk of controller damage if not completely connected.
- To connect units, the units must be mounted on a DIN rail. Attach end plates **MS-DIN-E** (optional) so as to enclose the connected units at the ends.
- Up to 15 slave units can be connected per master unit.
- When connecting slave units to a master unit, connect only NPN output types, or only PNP output types. Dissimilar output types cannot be connected together.

Connection method

1. Mount one master unit on the DIN rail.
2. Remove the connector cover.
3. Mount each slave unit one at a time on the DIN rail. Remove all connector covers except for the cover on the end slave unit.
4. Slide each slave unit to connect the female and male connectors.
5. Attach end plates **MS-DIN-E** (optional) with the flat side facing in so as to enclose the connected units at the ends.
6. Tighten the screws to fasten the end plates.

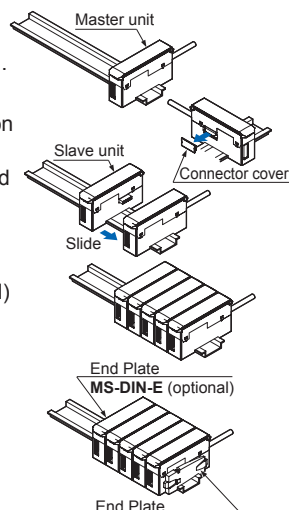

Removal method

1. Loosen the screws on the end plates
2. Remove the end plates.
3. Slide and remove the controllers, one at a time.

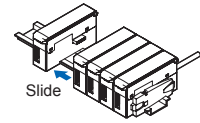

Common

Wiring

- The product is designed to fulfill the specifications when combined with the **HG-S** sensor head and **HG-SC** controller. If the product is used in combination with other products, it not only fails to meet the specifications but also generates a malfunction in some cases.
- For the controller DC power supply, only use a power supply that is isolated by means of an isolation transformer or otherwise.
- Risk of short-circuiting and damage to the controller or power supply if a transformer such as an auto transformer is used. Risk of short-circuiting and damage to the controller or power supply if incorrectly mounted or connected.

- Make sure that the power supply is OFF while performing wiring or expansion work.
- After you have completed wiring work, check the wiring carefully before switching on the power.
- Do not wire in parallel with a high-voltage line or power line, or run through the same conduit. Risk malfunctioning due to induction.
- Verify that the supply voltage fluctuations are within the rating.
- If power is supplied from a commercial switching regulator, ensure that the frame ground (F.G.) terminal of the power supply is connected to an actual ground.
- Do not use during the initial transient time after the power supply is switched ON.
- Do not apply stress such as excessive bending or pulling to the extracted part of a cable,

Others

- This device has been developed / produced for industrial use only.
- Do not use this product outside the range of the specifications. Risk of an accident and product damage. There is also a risk of a noticeable reduction of service life.
- This controller uses an EEPROM. The EEPROM has a service life of one million setting operations.
- This product is suitable for indoor use only.
- Avoid dust, dirt, and steam.
- Ensure that the product does not come into contact with organic solvents such as thinner.
- Ensure that the product does not come into contact with strong acid or alkaline.
- Ensure that the product does not come into contact with oil or grease.
- This product cannot be used in an environment containing flammable or explosive gases.
- Performance may not be satisfactory in a strong electromagnetic field.
- This product is a precision device. Do not drop or otherwise subject to shock. Risk of product damage.
- Never attempt to disassemble, repair, or modify the product.

DIMENSIONS (Units: mm in)

The CAD data can be downloaded from our website.

HG-S1010(R), HG-S1110(R)

Sensor head

**Standard type
HG-S1010 / HG-S1110**

**Low measuring force type
HG-S1010R / HG-S1110R**

Installation of sensor head connection cable

The diagrams show the sensor head connection cable connected to the low measurement force type.

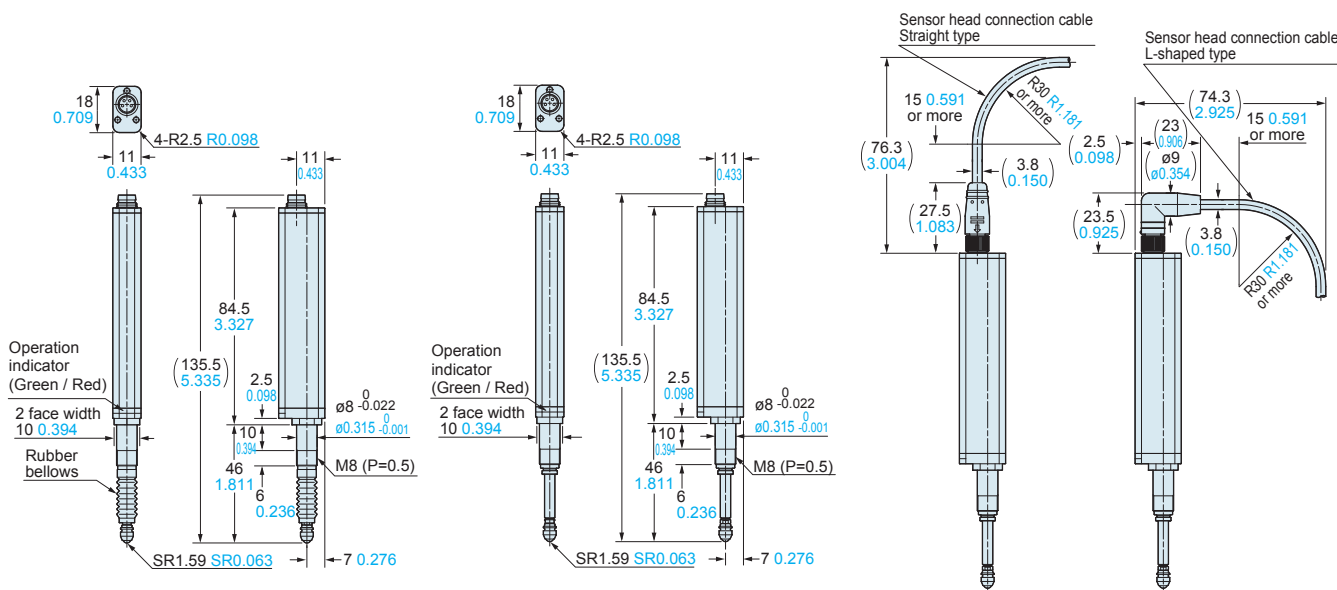

HG-SC101(-P)

Controller (Master unit)

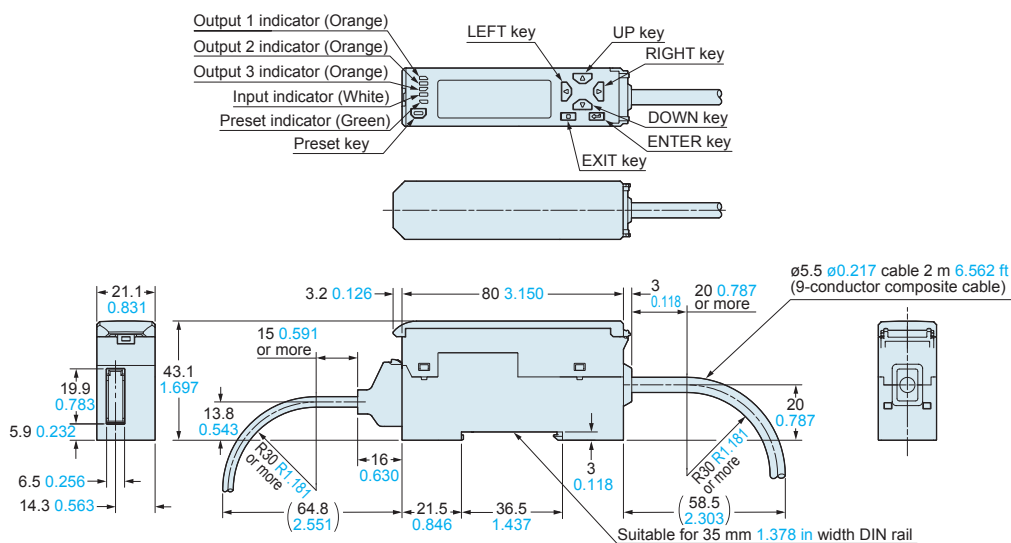

HG-SC111(-P) HG-SC112(-P)

Controller (Slave unit)

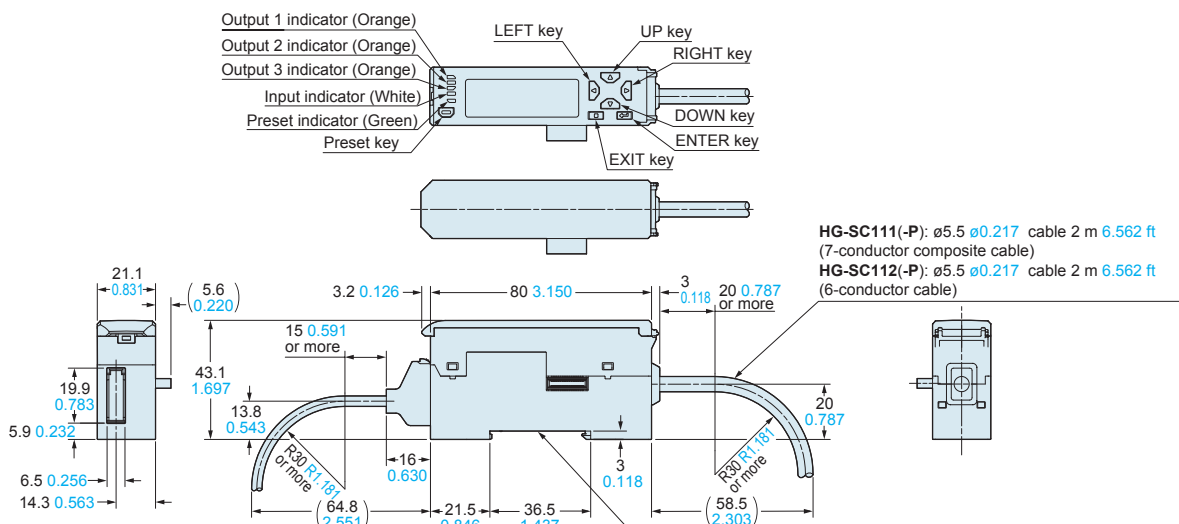

HG-SC113

Controller (Slave unit)

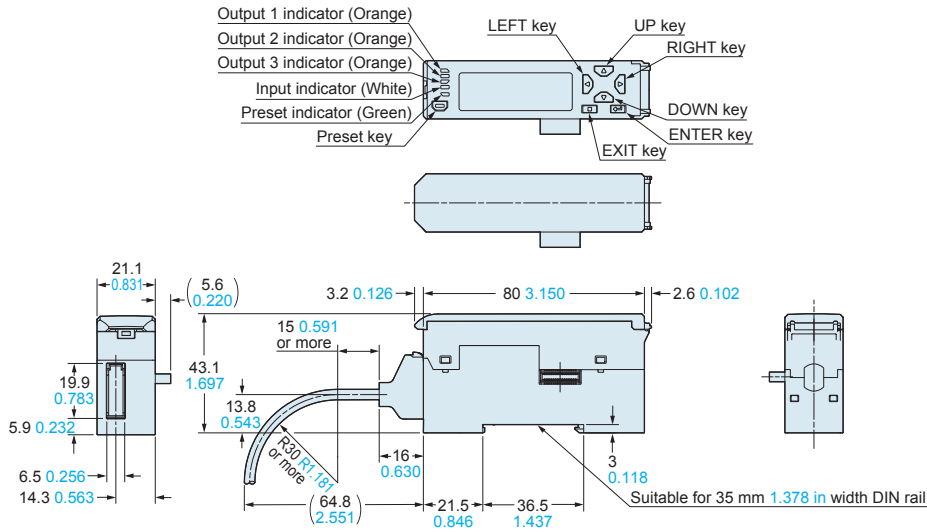

MS-DIN-E

End plate for controller (Optional)

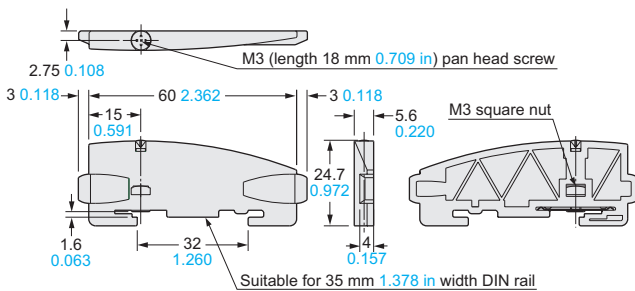

Material: Polycarbonate

Disclaimer

The applications described in the catalog are all intended for examples only. The purchase of our products described in the catalog shall not be regarded as granting of a license to use our products in the described applications. We do NOT warrant that we have obtained some intellectual properties, such as patent rights, with respect to such applications, or that the described applications may not infringe any intellectual property rights, such as patent rights, of a third party.

Panasonic Industrial Devices SUNX Co., Ltd.

Panasonic Industrial Devices SUNX Co., Ltd.