

BEFORE USE

Thank you for choosing M-System. Before use, please check contents of the package you received as outlined below.

If you have any problems or questions with the product, please contact M-System's Sales Office or representatives.

■ PACKAGE INCLUDES:

Encoder input module.....(1)

■ MODEL NO.

Confirm Model No. marking on the product to be exactly what you ordered.

■ INSTRUCTION MANUAL

This manual describes necessary points of caution when you use this product, including installation, connection and basic maintenance procedures.

POINTS OF CAUTION

■ CONFORMITY WITH EU DIRECTIVE

- Use dual-shield cables (Shinko Seisen Industry Model ZHY262 PBA) for the network. If it is not sufficient, use a ferrite core (Kitagawa Industries Model GRFC-13) for the network cable.
- The equipment must be mounted inside the instrument panel of a metal enclosure.
- The actual installation environments such as panel configurations, connected devices, connected wires, may affect the protection level of this unit when it is integrated in a panel system. The user may have to review the CE requirements in regard to the whole system and employ additional protective measures to ensure the CE conformity.

■ POWER INPUT RATING & OPERATIONAL RANGE

- Locate the power input rating marked on the product and confirm its operational range as indicated below:
 24V DC rating: 24V ±10%, approx. 80mA

■ GENERAL PRECAUTIONS

- Before you remove the unit or mount it, turn off the power supply and input signal for safety.
- DO NOT set the switches on the module while the power is supplied. The switches are used only for maintenance without the power.

■ ENVIRONMENT

- Indoor use.
- When heavy dust or metal particles are present in the air, install the unit inside proper housing with sufficient ventilation.
- Do not install the unit where it is subjected to continuous vibration. Do not subject the unit to physical impact.
- Environmental temperature must be within -10 to +55°C (14 to 131°F) with relative humidity within 30 to 90% RH in order to ensure adequate life span and operation.

■ WIRING

- Do not install cables close to noise sources (relay drive cable, high frequency line, etc.).
- Do not bind these cables together with those in which noises are present. Do not install them in the same duct.

■ AND

- The unit is designed to function as soon as power is supplied, however, a warm up for 10 minutes is required for satisfying complete performance described in the data sheet.

COMPONENT IDENTIFICATION

■ SIDE VIEW

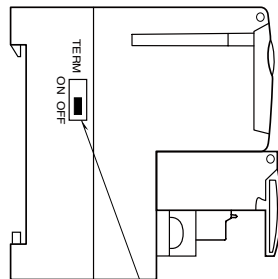

Terminating Resistor SW

■ FRONT VIEW

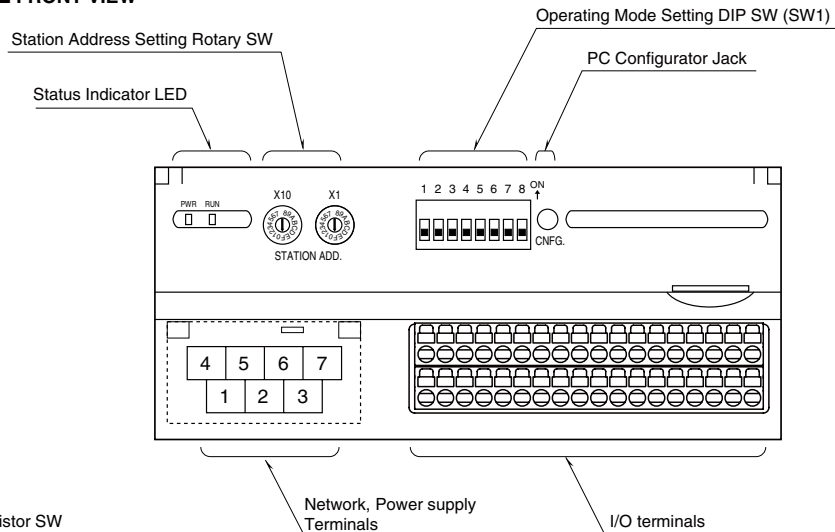

■ STATUS INDICATOR LED

ID	COLOR	FUNCTION
PWR	Green	Turns on when the internal 5V is supplied normally.
RUN	Green	Turns on when the refresh data is received normally.

■ STATION ADDRESS

The left switch determines the upper digit, while the right switch does the lower digit of the station address (hexadecimal number).

For Position Mode the data allocation is 4 while 2 for Speed mode.

Position mode

• Full-duplex communication

Setting “n” with the rotary switches, the addresses are n, n+2, n+4 and n+6. (Range: 01H to 39H)

• Half-duplex communication

4 addresses are assigned from the one set with the rotary switch. (Range: 01H to 3CH)

Address	CH0		CH1	
	Lower	Upper	Lower	Upper
Full-duplex	n	n+2	n+4	n+6
Half-duplex	n	n+1	n+2	n+3

Speed mode

• Full-duplex communication

Setting “n” with the rotary switches, the addresses are n and n+2. (Range: 01H to 3DH)

• Half-duplex communication

2 addresses are assigned from the one set with the rotary switch. (Range: 01H to 3EH)

Address	CH0	CH1
Full duplex	n	n+2
Half duplex	n	n+1



Station Address Setting (x1)

Station Address Setting (x16)

■ OPERATION MODE

(*) Factory setting

• Conversion data

SW1-1	CONVERSION DATA
OFF	Position data(*)
ON	Speed data

• Input range (speed)

SW1-2	SW1-3	SW1-4	INPUT RANGE
OFF	OFF	OFF	0 – 100 kHz (*)
ON	OFF	OFF	0 – 10 kHz
OFF	ON	OFF	0 – 1 kHz
ON	ON	OFF	0 – 100 Hz
OFF	OFF	ON	0 – 10 Hz
ON	OFF	ON	0 – 1 Hz
OFF	ON	ON	0 – 0.1 Hz

• Count mode (position)

SW1-5	SW1-6	COUNT MODE
OFF	OFF	Quad multiplication (Mode 3) (*)
ON	OFF	Double multiplication (Mode 2)
OFF	ON	Non-multiplication (Mode 1)
ON	ON	Non-multiplication (Mode 0)

• Transfer rate

SW1-8	TRANSFER RATE
OFF	12 Mbps (*)
ON	6 Mbps

Note: Be sure to set unused SW1-7 to OFF.

■ TERMINATING RESISTOR

To use the terminating resistor, turn the switch ON, and OFF to invalidate. (Factory setting OFF)

■ NETWORK, POWER SUPPLY TERMINAL ASSIGNMENT

• Full-duplex communication

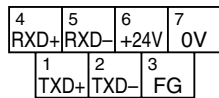

NO.	ID	FUNCTION, NOTES
1	TXD+	Network (slave, transmission +)
2	TXD-	Network (slave, transmission -)
3	FG	FG
4	RXD+	Network (master, transmission +)
5	RXD-	Network (master, transmission -)
6	+24V	Power input (24V DC)
7	0V	Power input (0V)

• Half-duplex communication

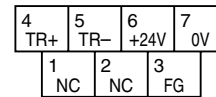

NO.	ID	FUNCTION, NOTES
1	NC	No connection
2	NC	No connection
3	FG	FG
4	TR+	Network
5	TR-	Network
6	+24V	Power input (24V DC)
7	0V	Power input (0V)

TERMINAL ASSIGNMENT

■ R7HL-PA2SA (open collector input, external sensor excitation)

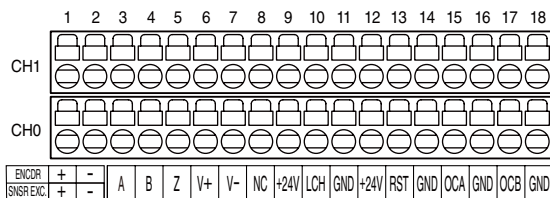

No.	ID	FUNCTION	No.	ID	FUNCTION
CH0	1	SNSR EXC.+	1	SNSR EXC.+	Encoder excitation input +
	2	SNSR EXC.-	2	SNSR EXC.-	Encoder excitation input -
	3	A	3	A	CH1 Phase A
	4	B	4	B	CH1 Phase B
	5	Z	5	Z	CH1 Phase Z
	6	V+	6	V+	Encoder excitation output +
	7	V-	7	V-	Encoder excitation output -
	8	NC	8	NC	Not used
	9	+24V	9	+24V	24V DC
	10	LCH	10	LCH	CH1 Latch input
	11	GND	11	GND	0V
	12	+24V	12	+24V	24V DC
	13	RST	13	RST	CH1 Reset input
	14	GND	14	GND	0V
	15	OCA	15	OCA	CH1 Open collector output A
	16	GND	16	GND	0V
	17	OCB	17	OCB	CH1 Open collector output B
	18	GND	18	GND	0V

■ R7HL-PA2SA/C (open collector input, sensor excitation available)

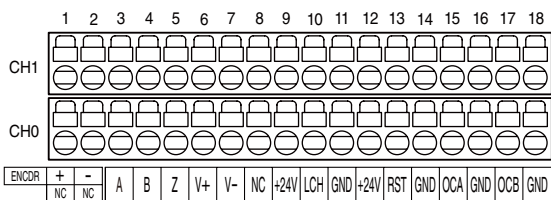

No.	ID	FUNCTION	No.	ID	FUNCTION
CH0	1	NC	CH1	1	ENCDR+
	2	NC		2	ENCDR-
	3	A		3	A
	4	B		4	B
	5	Z		5	Z
	6	V+		6	V+
	7	V-		7	V-
	8	NC		8	NC
	9	+24V		9	+24V
	10	LCH		10	LCH
	11	GND		11	GND
	12	+24V		12	+24V
	13	RST		13	RST
	14	GND		14	GND
	15	OCA		15	OCA
	16	GND		16	GND
	17	OCB		17	OCB
	18	GND		18	GND

PC CONFIGURATOR

With configurator software, settings shown below are available.
Refer to the software manual of R7CON for detailed operation.

■ CHANNEL INDIVIDUAL SETTING

• Speed data mode

PARAMETER	AVAILABLE RANGE	DEFAULT SETTING
Zero scale	-32000 to +32000	0
Full scale	-32000 to +32000	10000
Bias	-320.00 to +320.00	0.00
Gain	-3.2000 to +3.2000	1.0000
Drop out (cut out)	0.10 to 50.00 (%)	100.00 (%)

• Position data mode

PARAMETER	AVAILABLE RANGE	DEFAULT SETTING
Min.	-2,100,000,000 to +2,099,999,999	-2,100,000,000
Max.	-2,099,999,999 to +2,100,000,000	2,100,000,000
Reset Value	Min. to Max.	0

• Alarm

PARAMETER	AVAILABLE RANGE	DEFAULT SETTING
Alarm Type	0: Disable Alarm 1: Speed/High 2: Speed/Low 3: Position/High 4: Position/Low	0: Disable Alarm
Setpoint	Speed	-15.00 to +115.00 (%)
	position	Min. to Max.
Hysteresis (deadband)	Speed	0.00 to 115.00 (%)
	position	< (Max. – Min.)

• Latch and Reset setting

PARAMETER	AVAILABLE RANGE	DEFAULT SETTING
External Latch	0: Disable / 1: Enable	1: Enable
HLS Latch	0: Disable / 1: Enable	1: Enable
HLS Latch Data Clear	0: Disable / 1: Enable	1: Enable
External Reset	0: Disable / 1: Enable	1: Enable
HLS Reset	0: Disable / 1: Enable	1: Enable
HLS Reset Data Clear	0: Disable / 1: Enable	1: Enable
Z Reset	0: Disable / 1: Enable	1: Enable

■ CHANNEL BATCH SETTING

• Alarm batch Setting

PARAMETER	AVAILABLE RANGE	DEFAULT SETTING
HLS Command	0: Disable / 1: Enable	0: Disable
Power On Delay	0.0 to 60.0 (sec.)	5.0 (sec.)
On Delay Timer	0.0 to 60.0 (sec.)	0.1 (sec.)
On Hold Timer	0.0 to 60.0 (sec.)	0.1 (sec.)

TERMINAL CONNECTIONS

Connect the unit as in the diagram below.

EXTERNAL DIMENSIONS unit: mm (inch)

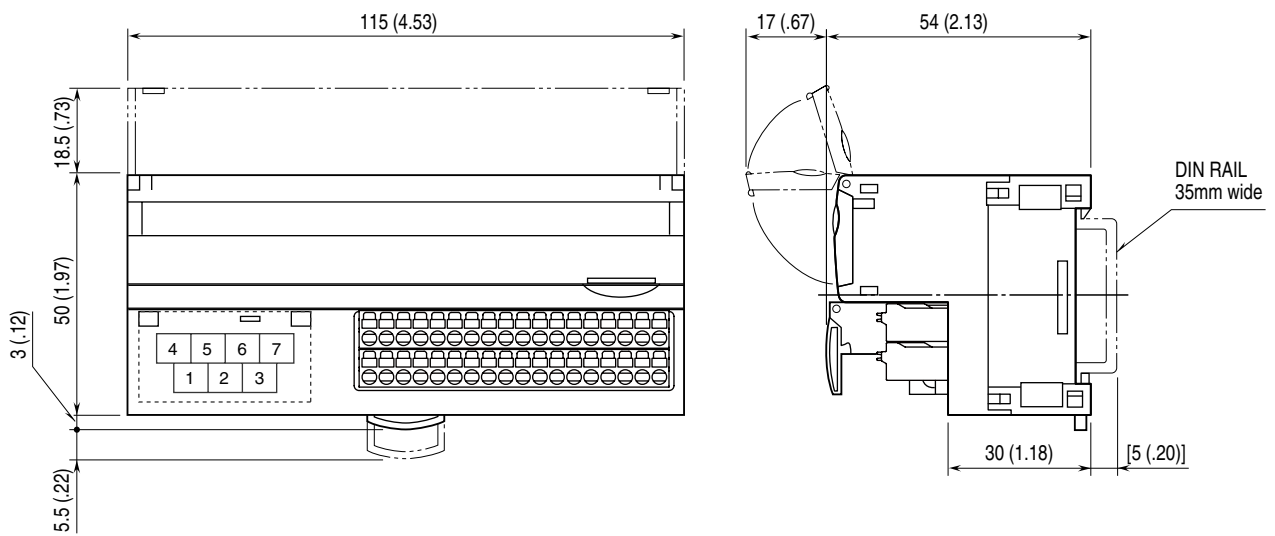

CONNECTION DIAGRAM

• R7HL-PA2SA (open collector input, external sensor excitation)

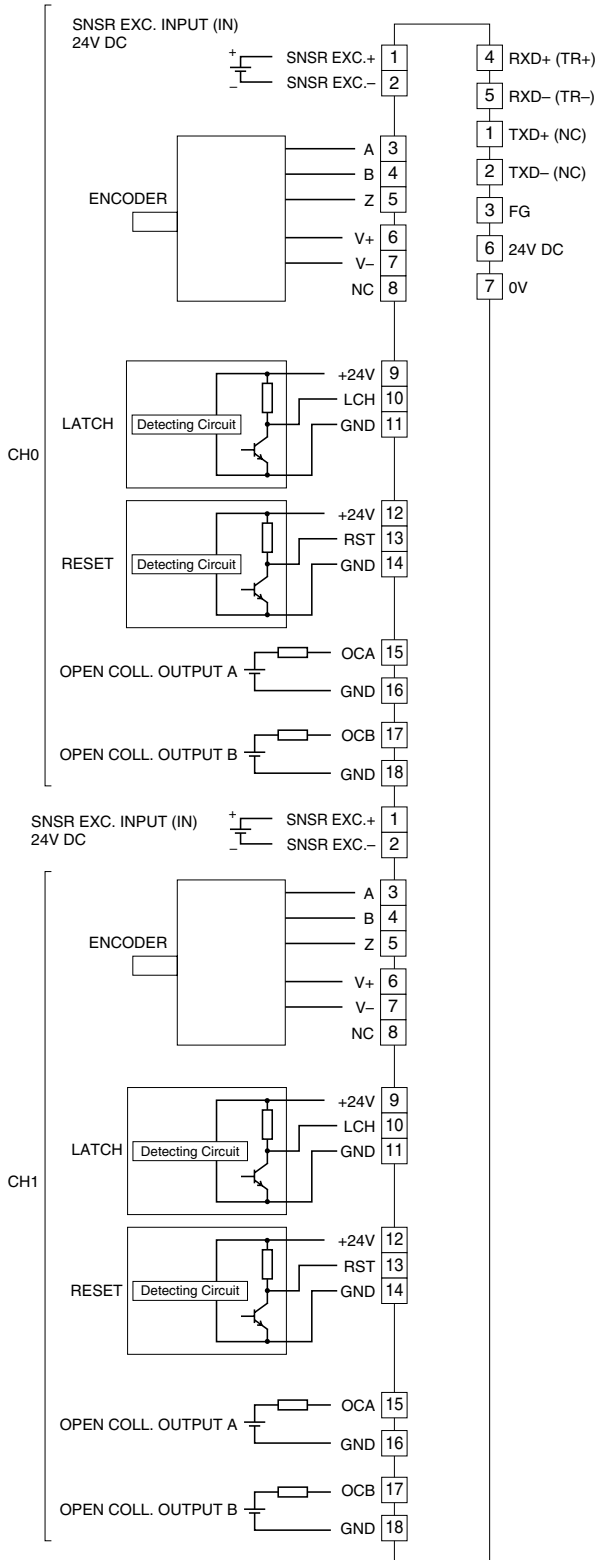

Note 1: Terminal numbers in parentheses are for half-duplex communication model.

Note 2: In order to improve EMC performance, bond the FG terminal to ground.

Caution: FG terminal is NOT a protective conductor terminal.

2-Wire Sensor (LATCH/RESET)

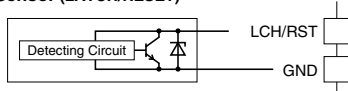

• R7HL-PA2SA/C (open collector input, sensor excitation available)

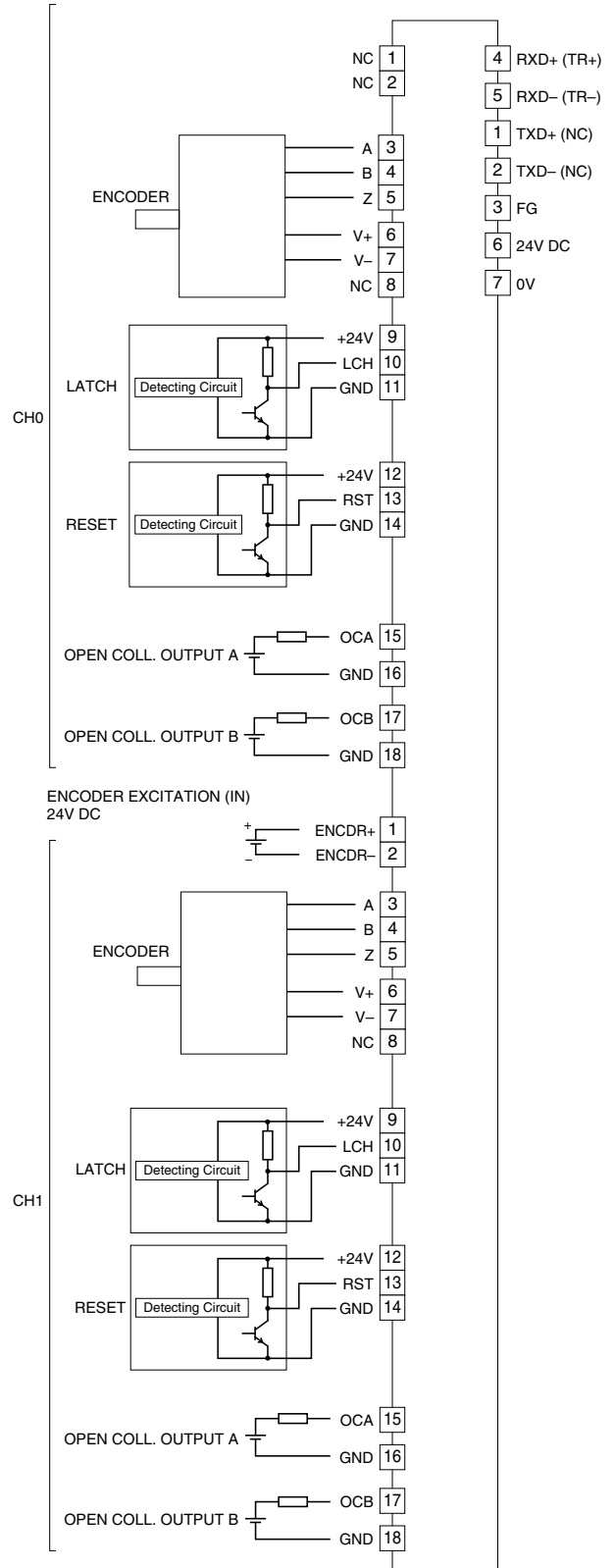

Note 1: Terminal numbers in parentheses are for half-duplex communication model.

Note 2: In order to improve EMC performance, bond the FG terminal to ground.

Caution: FG terminal is NOT a protective conductor terminal.

2-Wire Sensor (LATCH/RESET)

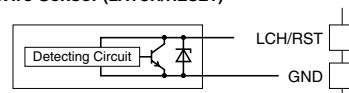

COMMUNICATION CABLE CONNECTIONS

■ MASTER CONNECTION

• Full-duplex communication

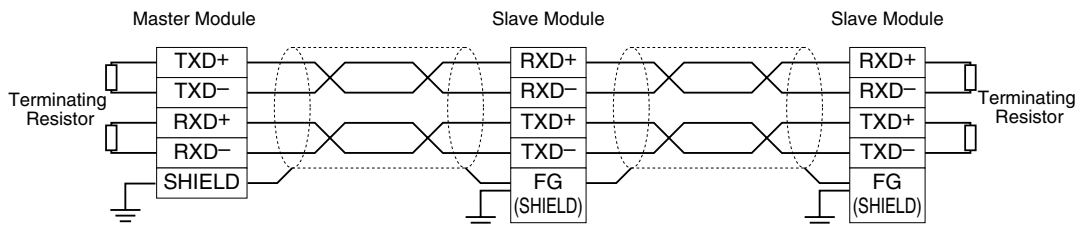

• Half-duplex communication

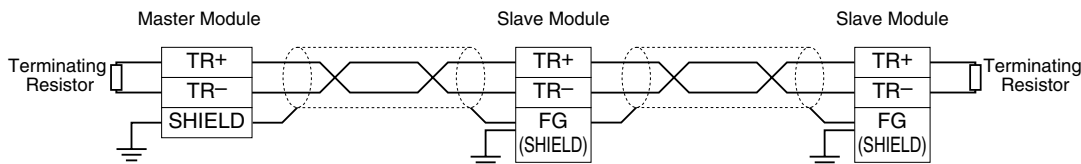

Note: Be sure to turn ON the switch of the terminating resistor located at both ends of the modules.

COUNT MODE

■ MODE 0 (non-multiplication)

1 count / 1 input pulse (count at either edge of phase A or B)

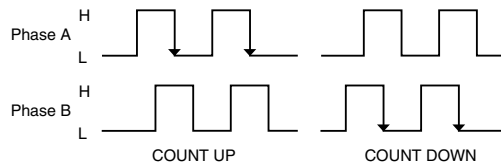

■ MODE 2 (double-multiplication)

2 counts / 1 input pulse (count at both edges of phase B)

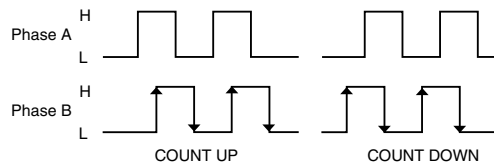

■ MODE 1 (non-multiplication)

1 count / 1 input pulse (count at either edge of phase A)

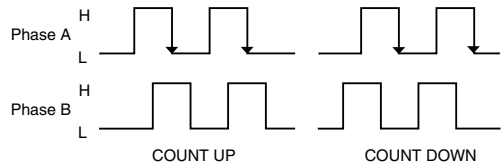

■ MODE 3 (quad-multiplication)

4 counts / 1 input pulse (count at both edges of phase A and B)

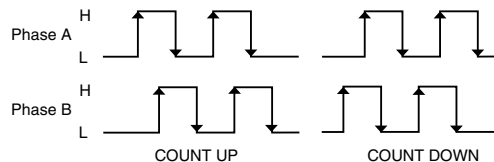

BIT ASSIGNMENT

■ POSITION DATA (Data allocation: 2 for each channel , total 4)

• Di area

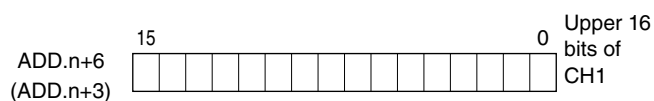
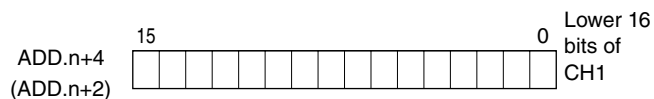
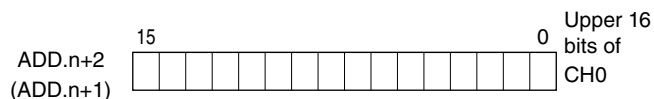
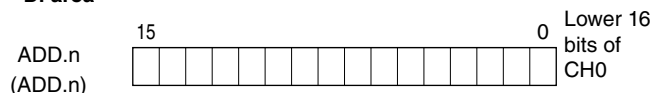

• Do area

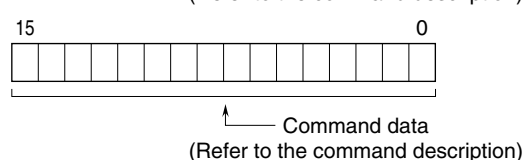
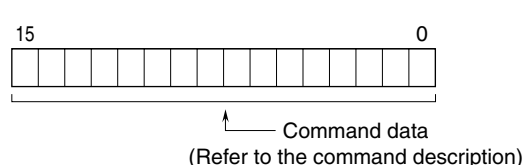
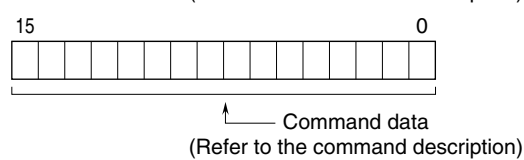
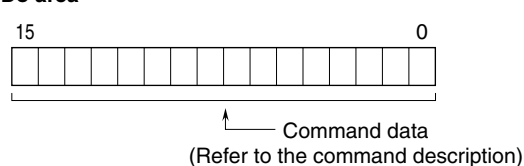

The data is 32-bit binary.
Addresses in parentheses are for half-duplex mode.

■ SPEED DATA*1 (Data allocation: 1 for each channel, total 2)

• Di area

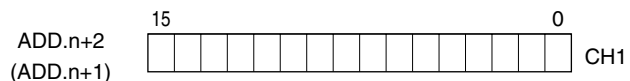
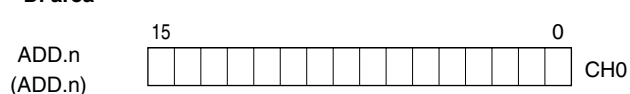

• Do area

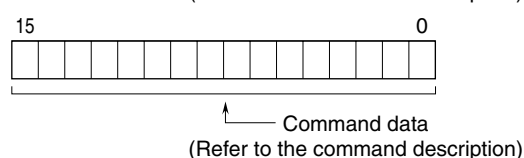
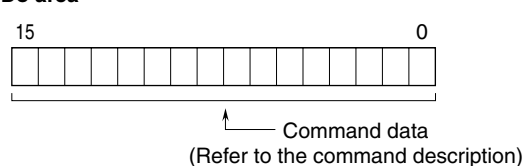

Speed data is described in 16-bit binary, which express the frequency range specified with SW1-2 to 1-4 as 10000.
Addresses for half-duplex are in parentheses.

*1. The PC Configurator is used to set scaling. For more information, refer to the R7CON Users Manual.

COMMAND DESCRIPTION

■ POSITION DATA

• Do area
ADD.n
(ADD.n)

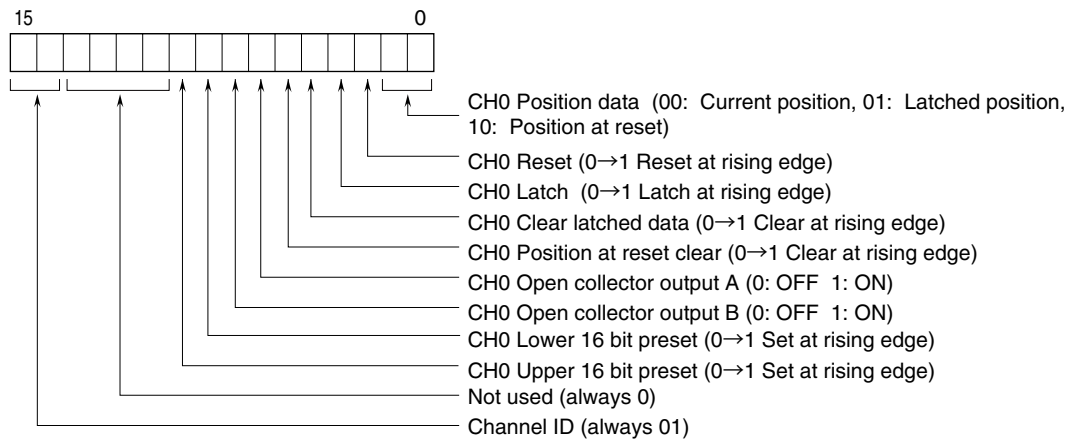

ADD.n+2
(ADD.n+1)

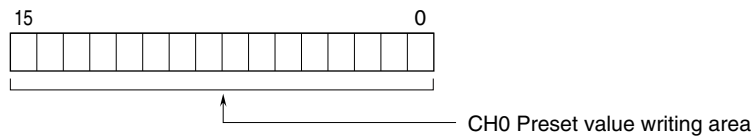

ADD.n+4
(ADD.n+2)

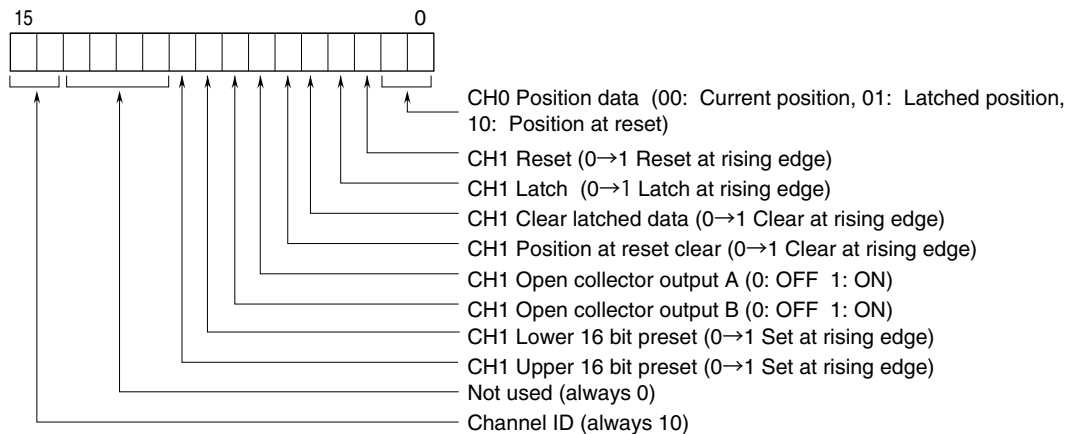

ADD.n+6
(ADD.n+3)

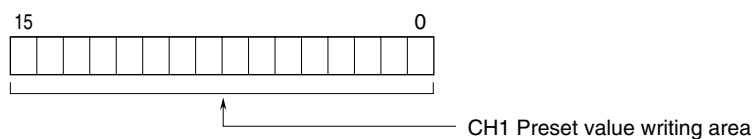

After execution of Reset, Latch, Reset data clear or Latch data clear command is confirmed, set the corresponding bit "0."
 If the bit remains "1," the command is not available for the next time.
 Open collector output command is available when the command is set enable with the R7CON, PC configurator software.

Addresses in parentheses are for half-duplex mode.

• Preset value setting procedure:

CH0 preset value setting

1. Write CH0 lower 16 bit preset value on ADD.n+2.
2. Write 4100H on ADD.n.
3. Write CH0 upper 16 bit preset value on ADD.n+2.
4. Upon writing 4200H on ADD.n, 32 bit preset value is reflected to current value data.
5. Write 4000H on ADD.n.

CH1 preset value setting

1. Write CH1 lower 16 bit preset value on ADD.n+6.
2. Write 8100H on ADD.n+4.
3. Write CH1 upper 16 bit preset value on ADD.n+6.
4. Upon writing 8200H on ADD.n+4, 32 bit preset value is reflected to current value data.
5. Write 8000H on ADD.n.

■ SPEED DATA

• Do area
ADD.n
(ADD.n)

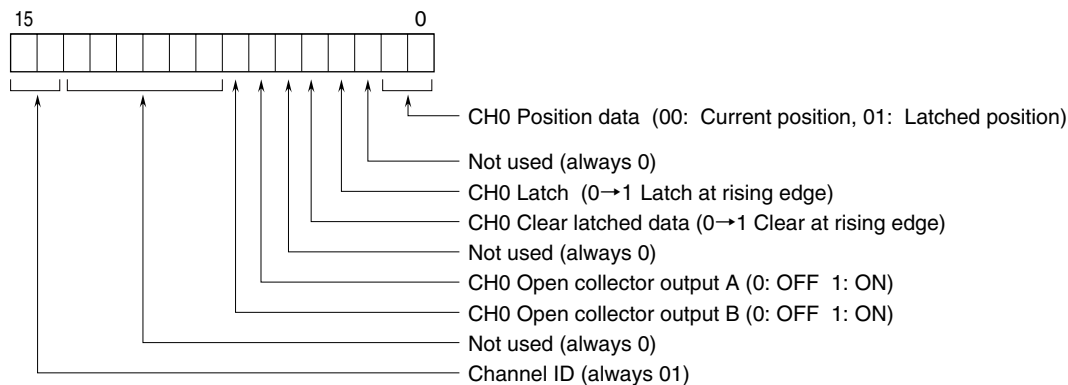

ADD.n+2
(ADD.n+1)

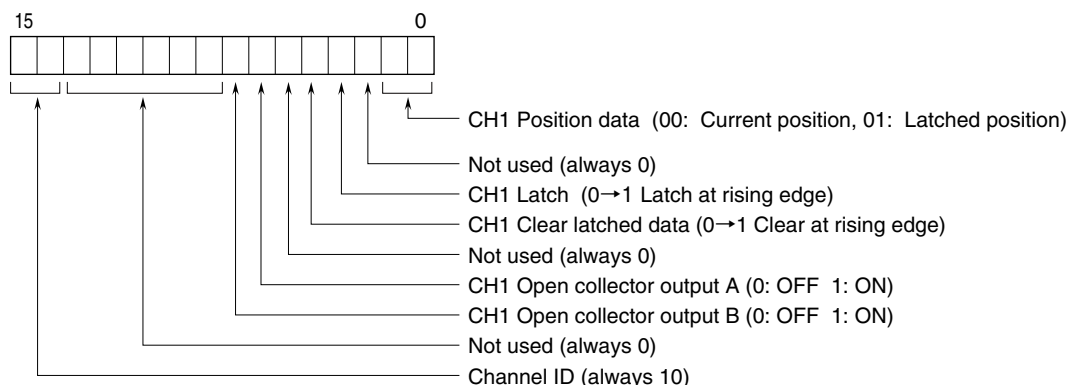

After execution of Latch or Latch data clear command is confirmed, set the corresponding bit “0.” If the bit remains “1,” the command is not available for the next time.

Open collector output command is available when the command is set enable with the R7CON, PC configurator software.

Addresses in parentheses are for half-duplex mode.

WIRING INSTRUCTIONS

■ SCREW TERMINAL

Torque: 0.5 N·m

■ SOLDERLESS TERMINAL

Refer to the drawing below for recommended ring tongue terminal size. Spade tongue type is also applicable.

Recommended solderless terminal:

• Communication cables

Applicable wire size: 0.2 to 0.5 mm² (AWG 26 to 22)

Recommended manufacturer: Japan Solderless Terminal MFG. Co., Ltd.

• Others

Applicable wire size: 0.25 to 1.65 mm² (AWG 22 to 16)

Recommended manufacturer: Japan Solderless Terminal MFG. Co., Ltd. or Nichifu Co., Ltd.

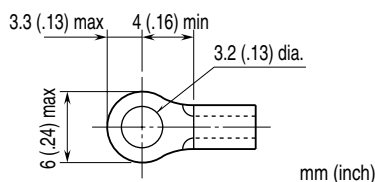

■ I/O TERMINAL

Applicable wire size: 0.2 – 1.5 mm²; stripped length 10 mm

Recommended solderless terminal

- AI0,25-10YE 0.25 mm² (Phoenix Contact)
- AI0,34-10TQ 0.34 mm² (Phoenix Contact)
- AI0,5-10WH 0.5 mm² (Phoenix Contact)
- AI0,75-10GY 0.75 mm² (Phoenix Contact)
- A1-10 1.0 mm² (Phoenix Contact)
- A1,5-10 1.5 mm² (Phoenix Contact)

For encoder input, use shielded twisted pair cable and the shield line must be grounded.