

SERVO-TOP II ELECTRONIC ACTUATOR
(rotary type; max. torque 200 N·m)

MODEL

PRP

BEFORE USE

Thank you for choosing M-System. Before use, please check contents of the package you received as outlined below.

If you have any problems or questions with the product, please contact M-System's Sales Office or representatives.

■ PACKAGE INCLUDES:

- SERVO-TOP II body(1)
- Wrench (manual operation lever)(1)
- Spare fuse*(1)

Note: Yoke and other components necessary to attach the PRP to a valve are to be provided by the customer.

*Attached to the inside of the terminal box cover.

■ MODEL NO.

Confirm Model No. marking on the product to be exactly what you ordered.

■ INSTRUCTION MANUAL

This manual describes necessary points of caution when you use this product, including installation and connection, hardware setting, and basic maintenance procedures.

With the failsafe function option selected, please also refer to PRP Instruction Manual for this option (EM-4823-A).

When you need to change software settings, please refer to the Operation Manual for Model PU-2x (EM-9255), Section B. This unit is factory adjusted and calibrated according to the Ordering Information included in the product package. If you do not need to change the pre-adjusted setting, you can skip the sections on PU-2x programming in this manual and the Operation Manual for Model PU-2x.

POINTS OF CAUTION

■ CONFORMITY WITH EU DIRECTIVES

- This equipment is suitable for Pollution Degree 2 and Installation Category II (transient voltage 2500V). Reinforced insulation (Signal or metallic housing or seq. signals or battery status (with failsafe function only) to power: 300V) is maintained. Prior to installation, check that the insulation class of this unit satisfies the system requirements.
- Altitude up to 2000 meters.
- The equipment must be installed such that appropriate clearance and creepage distances are maintained to conform to CE requirements. Failure to observe these requirements may invalidate the CE conformance.
- Install lightning surge protectors for those wires connected to remote location. Refer to "LIGHTNING SURGE PROTECTION" section below.

■ POWER INPUT RATING & OPERATIONAL RANGE

- Locate the power input rating marked on the product and confirm its operational range as indicated below:
 - 100 – 120V AC rating: 90 – 132V, 47 – 66 Hz, approx. 180 VA
 - 200 – 240V AC rating: 180 – 264V, 47 – 66 Hz, approx. 180 VA
- Power fuse: A glass tube power fuse (5.2 dia × 20 mm) of the rating as shown below is incorporated for safety. Be sure to remove the power supply before replacing it. Medium time lag, M 3 A 250 V

■ HUNTING

- The mode that the unit is operating at open/close operation or middle position with long term or intermittently. A rough indication of no hunting range is not more than '13 times operation/1 minute' (duty 50%).

■ GENERAL PRECAUTIONS

- Remove power supply to the actuator before wiring to it.
- Inside the cover, the metal plate mounting printed wiring boards located above the motor is also installed for heat dissipation. The motor and the plate may become extremely hot during operation. DO NOT touch them with bare hands.
- DO NOT install signal wires and power supply wires together in one duct because it may cause a malfunction due to inductive noises. If they must be installed together, use shielded cables.
- DO NOT step onto the actuator. DO NOT rest a heavy object on or against it.
- If input signals are to be turned on/off with power supplied to the actuator, be sure to set the input failure operation.
- The adjustments which are paint locked are for factory use only and should be changed only by qualified M-System personnel. M-System is not liable for any malfunction or inconvenience caused by unauthorized change of them by the user.

■ ENVIRONMENT

- Inside building. If outside, keep away from direct sunlight.
- Operating temperature -20 to +55°C (-4 to +131°F). When the ambient temperature can be less than 0°C (32°F), keep the power on except during installation or maintenance.
- Operating humidity 30 to 85% RH (non-condensing)
- The unit does not endure all vibration at installation site. It is not guaranteed that at low vibration with long term. Please use after evaluation with customer's installation environment. (Particularly avoid using at the place where there is water hammer, steam hammer or cavitation on the valve side.)
- The actuator must be installed in a place where maintenance and inspection can be conducted. Observe at least 15 cm (5.9 in.) of open space at the top of its cover for maintenance and inspection.
- Keep away from hazardous atmosphere such like explosive or corrosive gases.

■ SOUND ACCOMPANYING MOTOR ROTATION

- The PRP's stepping motor inherently generates whistling sound during normal operation according to its rotating frequency, larger with lower frequencies. DO NOT be alarmed.

■ MOUNTING POSITION

- When installing the PRP outdoor or where it is exposed to rain or water drops, adequate precaution must be done for preventing water from entering inside through wiring conduits.
- DO NOT mount the PRP in such direction that the output stem is at the top of the actuator.

■ PID CONTROL SIGNAL

- Choose PID parameters carefully so that the MV remains as stable as possible. Unstable control shortens the life of actuator and valve.

■ RUBBER PACKING

- Be sure to return the rubber packing when you close the cover after wiring or adjustments.

■ SCREW TORQUE

- The torque for tightening screws for the cover is between 2.4 – 3.1 N·m (1.8 – 2.3 ft·lbf).

■ DESIGNING YOKE

- When a foreign object is caught in the valve, torque greater than the maximum in the Table 4 and 5 could be applied to the yoke. Observe enough strength when designing mechanical components such like the yoke.
- When the PRP is used on a steam stream in temperature control, its temperature may rise beyond ambient temperature caused by a heat conducted or radiated from piping. Use a longer yoke for effective heat dissipation and apply insulation material.

COMPONENT IDENTIFICATION

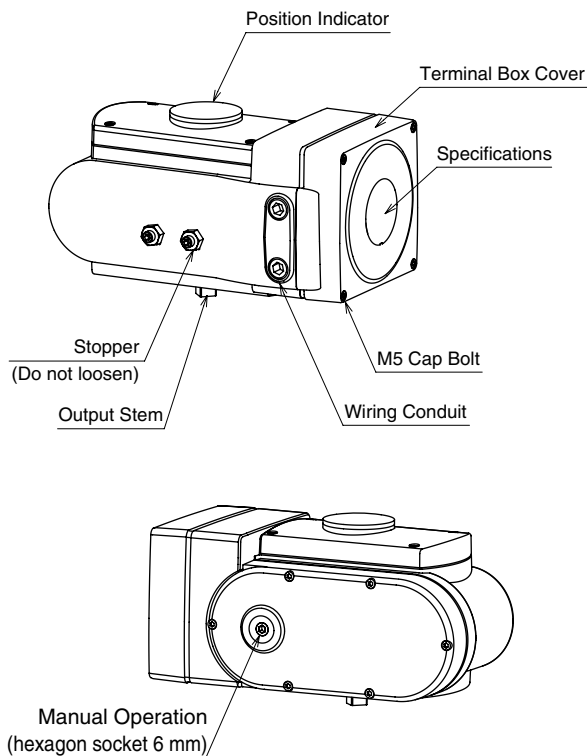

Figure 1. Component Identification

INSTALLATION

Valve, yoke, coupling and other components necessary to connect the PRP to the valve are provided by the customer. DO NOT CHANGE the ex-factory settings of the PRP. The following procedure should be done with the power supply removed, except when otherwise specified.

The following is the general procedure for mounting the actuator to a valve with a yoke and coupling.

E.g. 4 to 20 mA input

- 1) Supply power to the PRP and apply 4 mA DC. Turn the output stem to clockwise (seen from the cover).
- 2) Turn the valve stem to fully closed position (fully clockwise).
- 3) Set the yoke to the valve side.
- 4) Set the coupling to the valve stem and fit the PRP output stem into the coupling. Then fix the yoke and valve temporarily.
- 5) Fix the coupling so that there is no eccentricity between both stems.
- 6) Fix the yoke and valve firmly after checking the eccentricity of both stems again.

■ OUTPUT STEM DETAIL

- PRP-0x

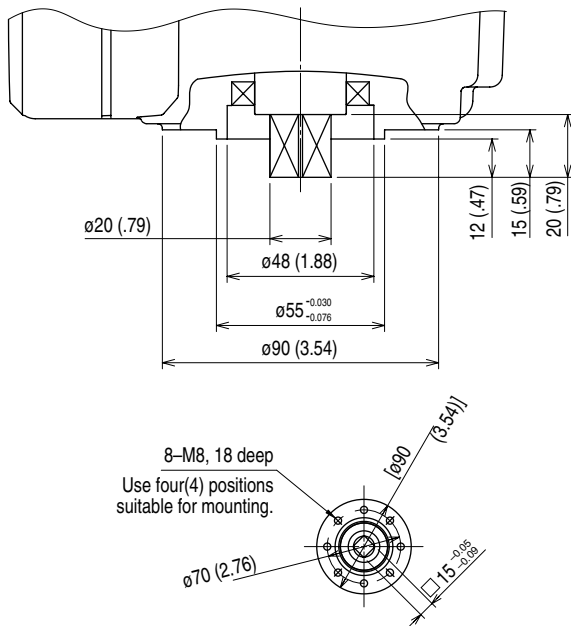

- PRP-1x (Compliant with ISO 5211 Table 1, 2 F07)

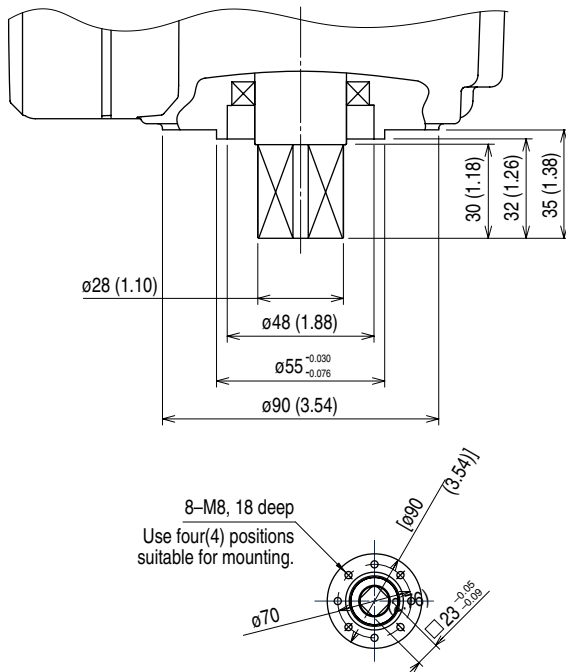
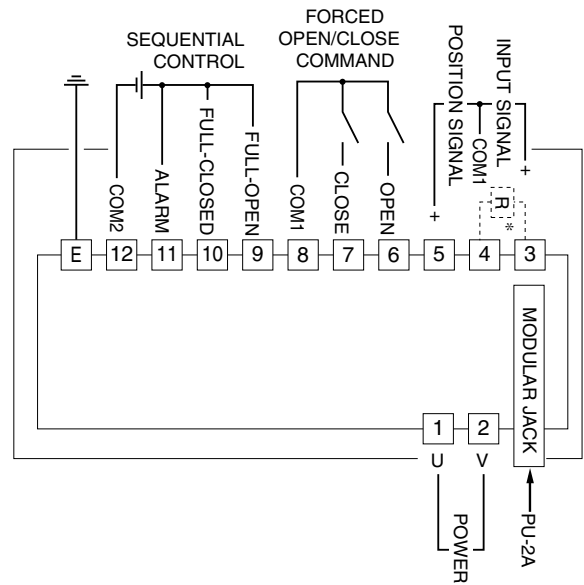

Figure 2. Output Stem Details

ELECTRICAL CONNECTIONS

Remove the cover of the terminal box and wire to the terminal block according to Figure 3.

The PRP requires the power input (1 – 2) and input signal (3 – 4) connections for operating.



*Input resistor attached for current input.

APPLICABLE SOLDERLESS TERMINAL

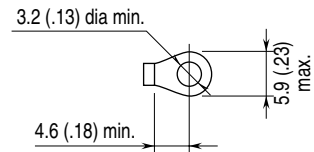
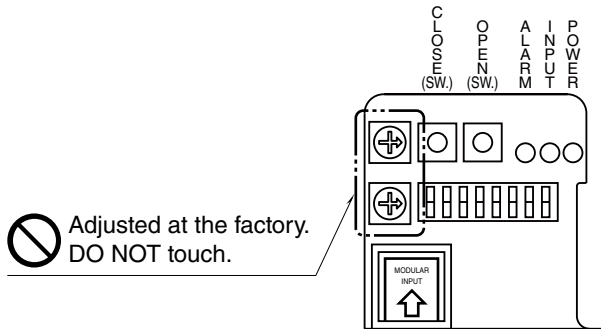

Figure 3. Connection Diagram & Applicable Solderless Terminal

ADJUSTMENT PROCEDURE

Open the terminal box cover and adjust the full-open and -closed positions referring to Figure 4. Other adjustments can be also conducted as explained below: switching actuator action, safety operation at input failure positions for the open/close limiters and for the full-open/close signal, and restart limiting timer.

For adjusting positions for the open/close limiters and for the full-open/close signal, restart limiting timer, and split range the PU-2x is required.



■ OPERATION AT INPUT FAILURE (SW-1, SW-2)

The stem stops when input fails at full-open, full-close, or the position where it is at the moment of failure (Hold). Factory default set to “Hold”.

When input signal returns, the output stem automatically returns to the position proportional to the input value. Refer to Table 1.

Table 1. NO INPUT & SWITCH POSITIONS

Stem position at input failure	SW-1	SW-2
Hold	*	ON
Stop at full-closed	OFF	OFF
Stop at full-open	ON	OFF

*SW-1 position is disregarded in STOP mode.

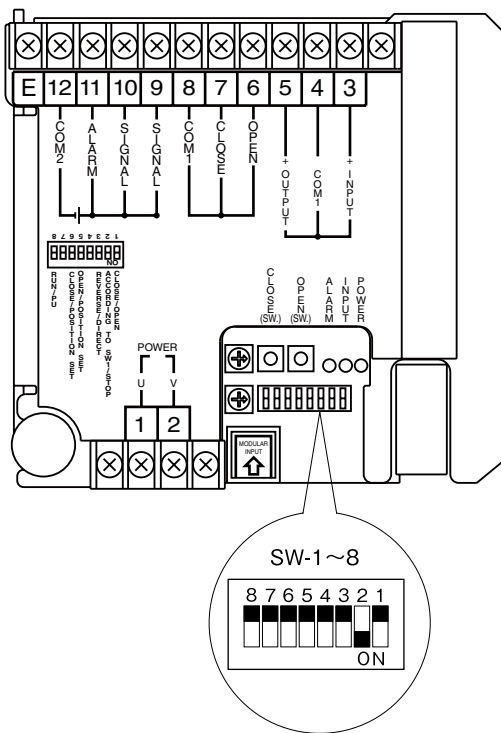

Figure 4. Adjustments, Details

■ ACTUATOR ACTION (SW-3)

Use SW-3 for switching the actuator action. It is set to “REVERSE” at the factory. Refer to Table 2.

Table 2. ACTUATOR ACTION

MODE	SW-3	ACTION
Reverse	OFF	Output stem turns counterclockwise with decreasing input. (valve closes)
Direct	ON	Output stem turns clockwise with decreasing input. (valve opens)

In DIRECT action, the input signal 4 – 20 mA DC corresponds to the position output signal 20 – 4 mA DC.

■ FULL-OPEN/CLOSED POSITIONS

- 1) Turn ON the SW-8 in order to put the PRP in the local calibration mode, and the input signal is disregarded.
- 2) Turn ON the SW-5 and adjust the full-open position pressing OPEN/CLOSE control buttons.
- 3) When the output stem reaches a desired position, turn OFF the SW-5. The position is memorized as the full-open position.
- 4) Turn ON the SW-6 and adjust the full-closed position pressing OPEN/CLOSE control buttons.
- 5) When the output stem reaches a desired position, turn OFF the SW-6. The position is memorized as the full-closed position.
- 6) Turn OFF the SW-8 in order to put the PRP in the operating mode. Apply input signals and confirm the full-open/closed positions.

Note: The operating angle between the Full-open and Full-close must be 45° or more.

PU-2x ADJUSTMENTS

■ DISPLAY

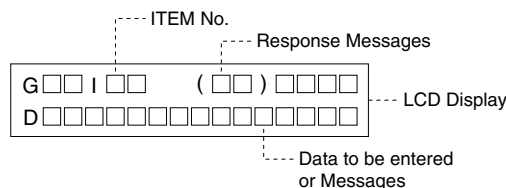

• Response Messages

- NG: No good
The PU-2x may not be securely connected. Check connection of the modular jack.
- ER: Communication error
Turn the SW-8 ON.

• Data Indicator

- OK: OK
- DATA-ERR: Invalid data input
- NON-ITEM: ITEM No. not applicable

■ PROGRAMMABLE ITEMS

Table 3. PROGRAMMABLE ITEMS

ITEM NO.	ITEM	USABLE RANGE	MINIMUM INCREMENT	DEFAULT
10	Full-open position	45 – 100 (%)	0.1	100
11	Full-closed position	0 – 55 (%)	0.1	0
12	Open side limit	75 – 105 (%)	0.1	100
13	Closed side limit	-5 – 25 (%)	0.1	0
14	Full-open output	75 – 100 (%)	0.1	96.4
15	Full-closed output	0 – 25 (%)	0.1	3.6
16	Split ON/OFF	0 or 1		0
17	Split type LO/ HI	0 or 1		0
18	Split point	30 – 70 (%)	0.1	50
19	Opening/closing speed	PRP-0x: 1 – 50 PRP-1x: 1 – 20	1	PRP-01: 30 PRP-03: 12 PRP-11: 20 PRP-13: 12
20	Dedband	0.1 – 5 (%)	0.1	0.5
21	Restart limiting timer	0 – 30 (sec.)	0.1	2
22	Opening/closing speed in failsafe operation*	PRP-0x: 1 – 50 PRP-1x: 1 – 20	1	PRP-01: 30 PRP-03: 12 PRP-11: 20 PRP-13: 12
23	Position in shutdown*	0 – 100 (%)	0.1	0

*Setting are enabled with ‘Failsafe’ option.
Note: The unit is not shown on the PU-2x display.

■ ROM VERSION INDICATION

Press ITEM 99 in the local calibration mode in order to display the ROM version of the PRP.

HOW TO PROGRAM THE PRP

- 1) Apply power supply voltage to the PRP.
- 2) Turn ON the SW-8 in order to put the PRP in the local calibration mode, and the input signal is disregarded.
- 3) Connect the modular jack cord of the PU-2x to the PRP.
ITEM display is blank.
- 4) Indicating Current Setting
Key in the ITEM No. that you want to check. (N = 0 to 9)
Press [ITEM] [N] [N].
- 5) Indicating New ITEM No.
Press [ITEM] [N] [N] or press [UP] or [DOWN].
- 6) Modifying Current Setting
Display the ITEM No. that you want to change, and press [DATA], new setting, and [ENTER].
If an irrelevant setting is entered, the PU-2x indicates "DATA-ERR" on its message display. Key in an appropriate setting again.
- 7) Remove the modular jack cord of the PU-2x.
- 8) Turn OFF the SW-8 in order to return the PRP in the operating mode. Apply input signals and confirm every setting.

Note 1: DO NOT remove power to the PRP with the PU-2x connected to it.

Note 2: Be sure to remove the PU-2x before driving the motor (in the operating mode).

EXPLANATIONS ABOUT THE PROGRAMMABLE ITEMS

- 1) Full-Open/-Closed Positions (ITEM No.10, 11)
Key in a percentage value within 0% for the turned fully CCW (close), and 100% for turned fully CW (open).
Note: The operating angle between the Full-open and Full-close must be 45° or more.
- 2) Open/Closed Side Limits (ITEM No.12, 13)
The adjustable ranges shown in Table 3 are applicable against the angle determined by the full-open/-closed positions as 100%.
- 3) Full-Open/-Closed Outputs (ITEM No.14, 15)
The adjustable ranges shown in Table 3 are applicable against the angle determined by the full-open/-closed positions as 100%.
- 4) Split Range (ITEM No.16 to 18)
Refer to Figure 5 and determine the type and point of split range.
When the split range is set to OFF (ITEM No.16), the split range type and point (ITEM No.17, 18) are invalid.

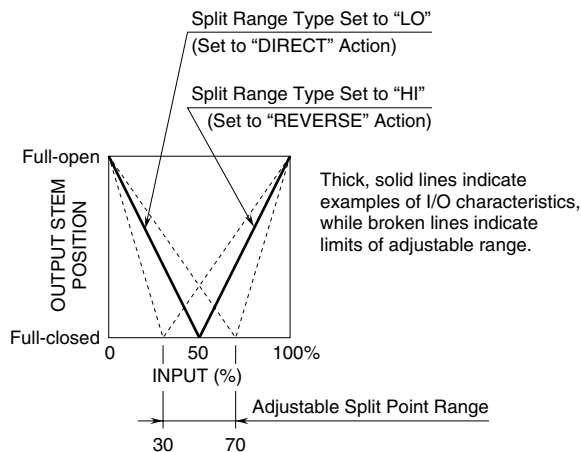

Figure 5. Split Range

5) Opening/Closing Speed Limit (ITEM No.19, 22)

Opening/closing speed affects the torque. Refer to Tables 4 – 5 and Figure 6 for checking required torque and attainable speed. The speeds for normal (No.19) and fail-safe (No. 22) operations can be set independently.

Acceleration or deceleration is not included in the speed. Acceleration or deceleration respectively requires approx. 0 to 2 sec.; takes longer with faster speed.

Table 4. PRP-0x OPENING/CLOSING SPEED

SPEED SCALE	OPERATION TIME [sec./90°]	TORQUE	
		[N·m]	[ft·lbf]
1	125	140	103
3	60	125	92
5	45	120	88
8	33	120	88
10	28	110	81
12	24	110	81
17	18	110	81
30	12	110	81
34	10	110	81
50	8.5	90	66

Table 5. PRP-1x OPENING/CLOSING SPEED

SPEED SCALE	OPERATION TIME [sec./90°]	TORQUE	
		[N·m]	[ft·lbf]
1	125	270	199
3	60	270	199
5	45	240	177
8	33	240	177
10	28	220	162
12	24	200	147
20	16	200	147

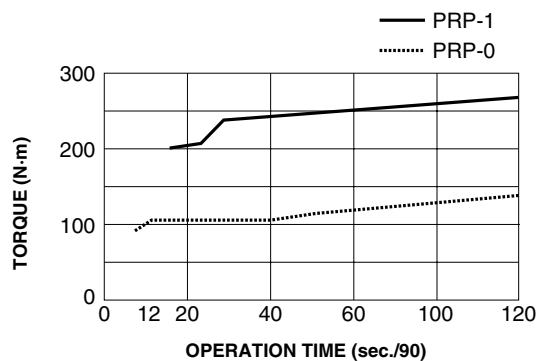

Note: Operational torque for PRP-0 is 100 N·m.
Operational torque for PRP-1 is 200 N·m.

Figure 6. PRP Speed V.S. Torque

6) Deadband (ITEM No.20)

Deadband is adjustable as % of the maximum angle within 0.1 to 5%.

7) Restart Limiting Timer (ITEM No.21)

The timer is provided to protect the motor from overheating, preventing it from restarting for a certain interval once the motor has been stopped within deadband.

When the high temperature protection is activated in a high temperature ambient, adjust the timer to a longer interval.

Adjustable range is within 0 to 30 sec.

8) FAILSAFE TARGET POSITION (ITEM No.23)

The output stem is automatically driven to a specific angle. Specify the angle determined by the full-open/-closed position as 100%.

MANUAL OPERATION

■ WHEN POWER IS AVAILABLE TO SUPPLY TO PRP

- 1) Turn on the power supply.
- 2) Turn on the SW-8 to put the PRP into the local calibration mode.
- 3) Use OPEN/CLOSE buttons to manually operate the PRP.
- 4) Turn off the SW-8 after turning off the power supply.

■ USING THE MANUAL OPERATION STEM

- 1) Be sure that the power supply is removed.
- 2) The output stem is designed to open (to turn clockwise seen from position indicator (Refer to the Figure 1)) when the manual operation axis turns clockwise (seen from the operational side). Attach the lever (the wrench supplied with the actuator) to the axis and turn it with checking the position indicator.
- 3) The output stem turns by 90° per approx. 10 turns of the manual operation axis.
- 4) When the operation is completed, be sure to remove the lever.
- 5) Be sure that the lever is not attached before turning on the power supply.
- 6) Hexagon key wrench (6 mm) is applicable.

PROTECTIVE FUNCTIONS

■ ERROR DETECTION

- When the position signal is deviated from the input signal but the output stem is stuck due to overload or certain malfunction, the PRP repeats starting the motor at the maximum torque for several times. If the stem is still stuck after that, the PRP outputs an alarm signal (LED turned ON) and stops power supply to the motor.
- In order to reset the PRP, apply several times 0% and 100% input signals in turn, or turn off and on the power supply.
- In case the alarm is ON frequently, check for foreign obstacles in the valve, inappropriate adjustments, or retightened gland packing or other possible causes of the overload.
Be sure to remove the cause of alarm in order to ensure appropriate life span.

■ ABNORMAL TEMPERATURE INCREASE PROTECTION

- When the incorporated temperature sensor detects an abnormal temperature increase in the motor, the PRP outputs an alarm signal (LED blinks in 0.5-sec. ON – 0.5-sec. OFF sequence) and stops power supply to the motor until the temperature decreases to an acceptable level.
- The PRP is designed to automatically recover power supply to the motor. It takes longer to recover normal operation when ambient temperature is higher.

■ PROTECTIVE FUSE

- A fuse is incorporated for protection against overcurrent in the control PCB and motor.
- If the power LED does not turn on with the power supplied to the actuator, check the fuse status.
- If a replaced fuse is blown quickly, it is possible that the control PCB and/or motor are damaged. Consult M-System or M-System's representative.

■ MOTOR PREHEATING

When the PRP detects a temperature lower than 0°C or 32°F (approximate) on the surface of its motor, the PRP supplies current to the motor in order to warm up and maintain its surface temperature at 5°C or 41°F (approximate). Maintain the power supply ON when the PRP is used in the ambient temperature below 0°C or 32°F. The power consumption at preheating is approx. 45VA.

MAINTENANCE

For effective use and longer life of the PRP, regular checking appropriate for its operating conditions are recommended. Refer to the following table.

ITEM	CHECKING POINT	HOW TO PROCEED
Functioning (E.g. 4 to 20 mA input)	Apply input 4 mA → 12 mA → 20 mA → 12 mA → 4 mA. Check the actuator operations and positions at each input value.	Repair or calibration If the alarm indicator LED is on, check that the valve operates lightly and smoothly.
Abnormal sound	No abnormal sound is heard during operation.	Repair or calibration
Connector Leadwire	The connector is firmly connected. No breakdown of leadwires. The insulation covers are not torn, not bruised.	Repair or calibration
Inside humidity, rust	No condensation. No rust. If there is water inside, check the rubber packing and O-ring.	Remove water, dry the case and inside parts. Replace rusted parts. Calibration. If the rubber packing and O-ring are damaged, replace them.
Screws	Check that screws and bolts are securely fastened.	Re-tighten them.
Nut	Check that the nut at the valve stem is not loose.	Re-tighten it and calibrate.

For repair or parts replacement, contact M-System or representatives.

■ LUBRICATION

There is no need of oiling the PRP in normal operating conditions.

■ REGULAR TEST RUNNING

If the valve is not frequently operated, run a test operation regularly (once a week, for example) to check proper functions.

TROUBLESHOOTING

TROUBLE		POSSIBLE CAUSE	HOW TO PROCEED
Not functioning	Power and/or input indicator OFF	Power and/or input signal is not supplied.	Check power and input signals, remove the causes of malfunction and secure the signals.
		Wiring error.	Check the wiring.
		Bad contact.	Check the connector and other connecting sections.
		Fuse melted.	Replace it with a new one.
	Power and/or input indicator ON	The actuator is in local calibration mode (SW-8 ON).	Turn SW-8 OFF.
		Improper adjustments of full-open/-closed positions.	Adjust the full-open/-closed positions.
		Control PCB damaged.	Repair and calibration.
		Motor damaged.	Repair and calibration.
Unstable functioning		Abnormality in power voltage or input signal.	Remove the causes of malfunction and secure the signals.
		Operating speed is too fast.	Secure the required torque by slowing.
		Power voltage is too low or fluctuating.	Secure the required level of voltage.
		Input is unstable.	Check the controller and cables. Eliminate noise.
		Angle sensor is damaged.	Repair and calibration.
Alarm indicator ON		Overload caused by a foreign object caught in the valve.	Remove the causes of overload.
		Actuator mechanism damaged.	Repair and calibration.
Alarm indicator blinking		Motor temperature is abnormally high.	Use the restart limiting timer. Review MV value from the controller.
		Wiring of the temperature sensor is broken or the connector is detached.	Check the connector and leadwires.

For repair or parts replacement, contact M-System or representatives.

LIGHTNING SURGE PROTECTION

M-System offers a series of lightning surge protectors for protection against induced lightning surges. Please contact M-System to choose appropriate models.

SERVO-TOP II ELECTRONIC ACTUATOR

(rotary type; max. torque 200 N·m; failsafe function)

MODEL

PRP

POINTS OF CAUTION

REGARDING FAILSAFE TYPE ACTUATOR (EMERGENCY USE)

■ INSTRUCTION MANUAL

This manual describes necessary points of caution when you use the PRP with the failsafe function.

Please also refer to the Instruction Manual for the PRP (EM-4823 Rev.1 or later).

M-System is not liable for any malfunction or inconvenience caused by unauthorized change of them by the user.

■ GENERAL PRECAUTIONS

- The PRP is shipped with the battery connector disconnected in order to prevent discharges. When you first use the PRP, connect the battery and charge it for more than three hours. Charge also after you replace the battery.
- There is no need to connect the battery connector for adjustments during installation of a valve. Adjustments can be conducted with a line power.
- Turn off the power supply for safety when wiring to the PRP.
- Disconnect the battery connector in order to prevent unnecessary discharges if you leave the PRP without power supplied for a long time.

■ ENVIRONMENT

- Inside building. If outside, keep away from direct sunlight.
- Ambient temperature: -20 to 55°C (-4 to 131°F)
- When the ambient temperature can be less than 0°C (32°F), keep the power on except during installation or maintenance.
- Operating humidity 30 to 85% RH (non-condensing)
- Vibration 2 G (19.6 m/s²) max.
- The actuator must be installed in a place where maintenance and inspection can be conducted. Observe at least 15 cm (5.9 in.) of open space at the top of its cover for maintenance and inspection.
- Keep away from hazardous atmosphere such like explosive or corrosive gases.

■ WIRING

- Do not install power supply and signal cables in the same duct in order to prevent malfunctions caused by induced noise. If they need to be installed closely, use shielded cables.

GENERAL DESCRIPTIONS

The PRP with Option /E has, in addition to the control valve actuator function, a failsafe function in case of no or abnormally low power input voltage.

In such cases, the actuator automatically goes to the preset position such as full-closed using the internal battery. A specific opening/closing speed for the safety shutdown operation can be also set.

When the power supply to the actuator is turned on, the PRP charges the battery first in rapid charge and then, detecting so-called 'minus delta V'* or after 180 minutes (approx.), moves to the trickle charge mode.

After the rapid charge cycle, the PRP's red BAT. STATUS LED turns on and the BAT. STATUS contact signal is output if the battery voltage is greater than approx. 22.5V. If the voltage level is lower, the LED blinks and the contact signal turns on and off synchronously with the LED.

*Minus Delta V: A characteristic bump of voltage increase curve at the battery terminals toward the end of rapid charge.

COMPONENT IDENTIFICATION

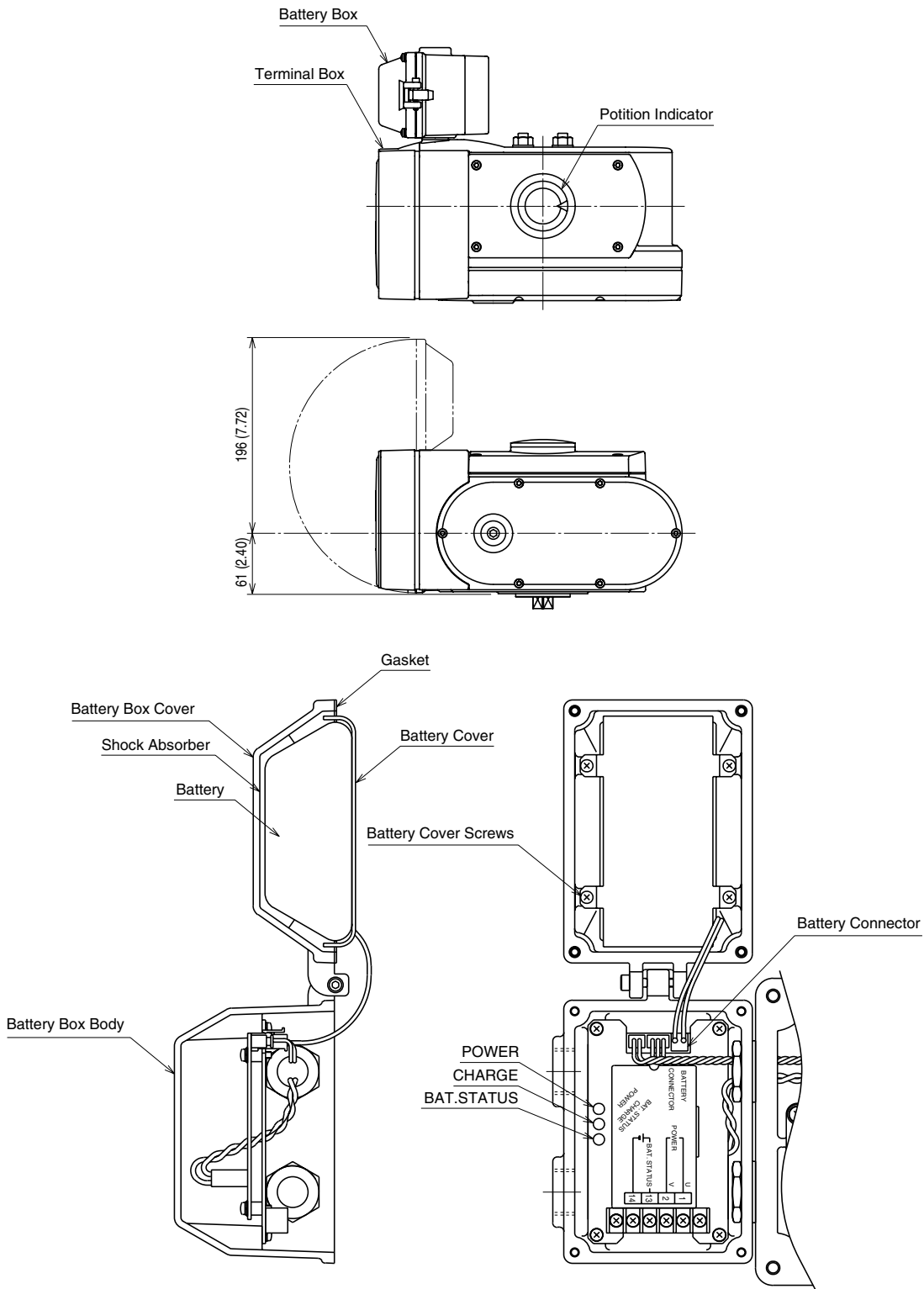

POWER : Power Indicator LED (red LED turns on with the power supplied)
 CHARGE : Charging Indicator LED (red LED turns on during charging)
 BAT. STATUS: Battery Status Indicator LED (red LED turns on in normal conditions; blinks in an abnormality.)

Figure 1. Component Identification

ELECTRICAL CONNECTIONS

Remove the covers of the PRP body and the battery box. Connect the signal input, position output and other signals to the body terminal block and the power input to the battery box terminal block according to Figure 2.

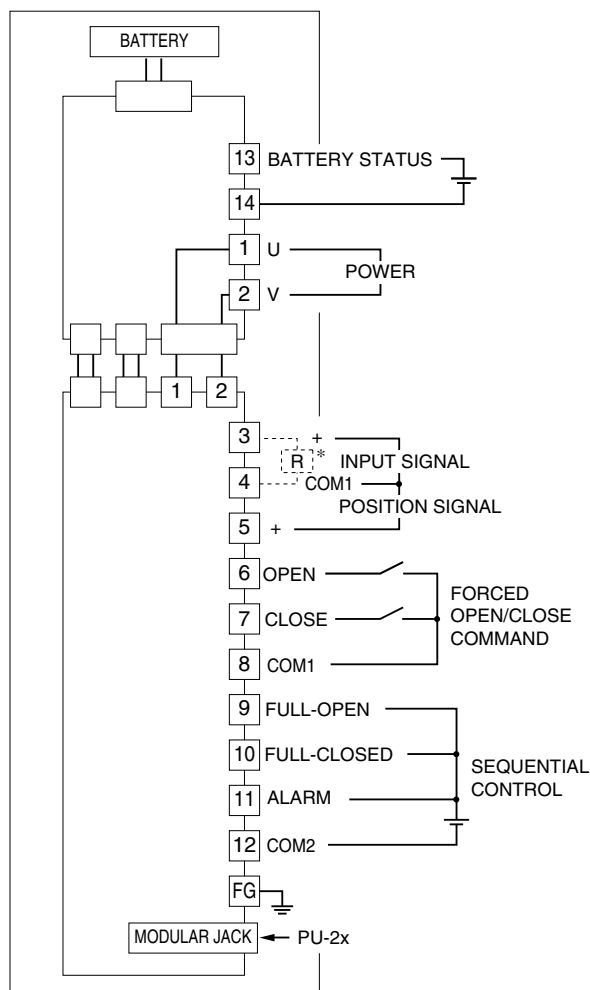

*Input resistor attached for current input.

APPLICABLE SOLDERLESS TERMINAL

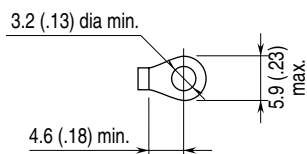

Figure 2. Connection Diagram & Applicable Solderless Terminal

PU-2x ADJUSTMENTS

Target position and opening/closing speed in the failsafe operation are field configurable.

Table 1 shows voltage levels determining 'Abnormally Low Voltage.'

Open the PRP body cover and connect the Programming Unit (model: PU-2x). Refer to the PRP Instruction Manual (EM-4823) for detailed procedures using the Programming Unit.

Table 1. VOLTAGE LEVELS DETERMINING ABNORMALITY

POWER INPUT RATING	ABNORMAL VOLTAGE
100 – 120V AC	65 – 80V AC or less
200 – 240V AC	180 – 160V AC or less

■ FAILSAFE TARGET POSITION (ITEM 23)

The output stem is automatically driven to a specific angle. The factory default setting is 0% (full-closed).

■ FAILSAFE OPENING/CLOSING SPEED (ITEM 22)

Opening/closing speed can be set specifically for failsafe operation, independently from the speed in normal operations. The factory default setting is shown in Table 2.

Table2. FAILSAFE OPENING/CLOSING SPEED

MODEL	DEFAULT
PRP-01	12 sec./90°
PRP-03	24 sec./90°
PRP-11	16 sec./90°
PRP-13	24 sec./90°

Note: Note that the speed affects the torque: faster speed, smaller torque.

HOW TO REPLACE THE BATTERY

- 1) Be sure to turn off the power supply.
- 2) Open the battery box cover.
- 3) Pull out the connector while holding down the latching. DO NOT pull at the cables.
- 4) Loosen the screws on top of the battery cover (4 places) and remove the cover. Remove the battery inside.
- 5) Replace a new battery (model: PSN-BAT) and put the cover on. Be careful that the wires are positioned in right direction and not caught at the edge of the cover.
- 6) Push in the connector back. Be sure that the latching is in right position.
- 7) Close the battery box cover. Be careful that the wires are not caught.

MAINTENANCE

For effective use and longer life of the PRP, regular checking appropriate for its operating conditions are recommended. For repair or parts replacement, contact M-System or representatives.

CHECKING POINT	HOW TO PROCEED
Set the PRP's output stem angle farthest from the failsafe target position. Turn the power supply off, then check the following points. <ul style="list-style-type: none"> • The PRP turns to the target position. • The PRP turns smoothly without making frequent start/stop movement. 	Check that the connector is firmly connected. Re-set the failsafe opening/closing speed (ITEM 22) to an appropriate value to get enough torque.
Turn the power supply on, then the BAT. STATUS indicator LED turns ON within three (3) hours.	Refer to the table below and check the battery status.

BATTERY STATUS	LED STATUS WITH POWER SUPPLY ON	HOW TO PROCEED
Discharged	<p>POWER and CHARGE LED turn ON and then BAT. STATUS turns ON. Rapid charge is complete within approx. 180 minutes (T) and CHARGE LED turns OFF.</p>	Normal
Full charge	<p>All three (3) LEDs turn ON and only CHARGE LED turns OFF after a while.</p>	Normal
No connection	<p>POWER LED turns ON and BAT. STATUS LED blinks.</p> <p>..... Blinking</p>	Check that the battery connector is firmly connected; check also for wire breakdown.
End of life	<p>POWER and CHARGE LED turn ON. CHARGE LED turns OFF after approx. 180 minutes (T) and BAT. STATUS LED blinks.</p>	Replace with a new battery.

■ BATTERY

The NiCad battery is designed for long life and does not need any special care. However, please check periodically for a leak and rust on and around the battery.

Battery's life is affected by many factors in complex way and can not be determined easily. To give an indication, we recommend a new battery replacement every three (3) years.

■ TEST OPERATION

If the actuator is to be stopped for a long time, run a test operation regularly (every three months, for example) to check proper functions.

TROUBLESHOOTING

TROUBLE	POWER LED	CHG LED	BAT LED	POSSIBLE CAUSE	HOW TO PROCEED
Not functioning	OFF	----	----	Wiring error	Check the connector and other connecting sections.
				Abnormal power supply voltage	Check the power source.
				Fuse melted	Replace the fuse.
	ON	----	Blink	Battery connector is not secured.	Check that the battery connector is firmly connected; check also for wire breakdown.
				End of battery life	Replace it with a new one.
	ON	ON	OFF	Rapid charging	Wait until the rapid charge is complete.
ON	OFF	ON	Control PCB is damaged.	Repair	

---- Any state.

LIGHTNING SURGE PROTECTION

M-System offers a series of lightning surge protectors for protection against induced lightning surges. Please contact M-System to choose appropriate models.