

MINI-TOP ELECTRONIC ACTUATOR
(linear type)

MODEL **MSP4/MSP5/MSP6**

BEFORE USE

Thank you for choosing M-System. Before use, please check contents of the package you received as outlined below. If you have any problems or questions with the product, please contact M-System's Sales Office or representatives.

PACKAGE INCLUDES:

- Mini-Top actuator unit.....(1)
 - 2.5 mm Hexagon key wrench(1)
- (For models with manual operation function; option /S)

The Mini-Top is not provided with a yoke or other components required for mounting the unit to a valve. They are to be provided by the user.

MODEL NO.

Confirm Model No. marking on the product to be exactly what you ordered.

POINTS OF CAUTION

CONFORMITY WITH EU DIRECTIVES AND UK LEGISLATION

- This equipment is suitable for Pollution Degree 2 and Measurement Category II (Full-open/-closed signal, transient voltage 1500V). Reinforced insulation (Full-open/-closed signal to other, power or metallic housing: 125V) is maintained. Prior to installation, check that the insulation class of this unit satisfies the system requirements.
- Refer to M-System's website for more information about the legislations and designated standards of UKCA.
- Altitude up to 2000 meters.
- The equipment must be installed such that appropriate clearance and creepage distances are maintained to conform to CE and UKCA requirements. Failure to observe these requirements may invalidate the CE and UKCA conformance.
- Install lightning surge protectors for those wires connected to remote location. Refer to "LIGHTNING SURGE PROTECTION" section below.

POWER INPUT RATING & OPERATIONAL RANGE

- Locate the power input rating marked on the product and confirm its operational range as indicated below:
 100 – 120V AC rating: 90 – 132V, 47 – 66 Hz, approx. 25VA
 200 – 240V AC rating: 180 – 264V, 47 – 66 Hz, approx. 25VA
 24V AC rating: 24V AC±10%, 47 – 66 Hz, approx. 25VA (MSP6)
 24V DC: 24V rating ±10%, approx. 0.6A
- Built-in power fuse: 250V/1A rating; time delay.
- A rush current 1.5 times as high as the above ratings can flow at startup.

GENERAL PRECAUTIONS

- Remove the power supply to the actuator before wiring.

INSTALLATION

- Indoor, or outdoor where the MSP is NOT exposed to direct sunlight
- Ambient temperature: -5 to +55°C (23 to 131°F)
- Operating humidity 30 to 85% RH (non-condensing)
- Vibration: 2 G (19.6 m/s²) max.
- Install the MSP where it can be reached for maintenance and inspection. Be sure to allow at least 15 cm (6 inches) clearance above the cover.

OUTDOOR USE

- When installing the MSP outdoor or where it is exposed to rain or water drops, be sure to fasten the cable connector tightly and give some slack to the cable.
- Do not mount the MSP in such a direction that the output stem or cable connector faces upward.

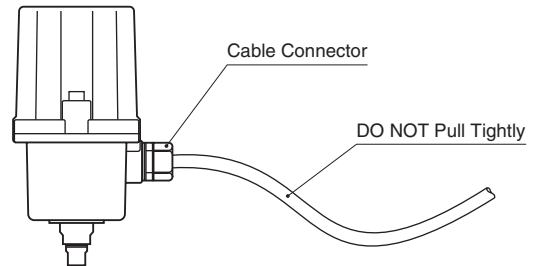

ELECTRICAL CONNECTION

- If the unit is a DC-powered model, power supply and signal lines are not isolated. Use an isolator, if needed.
- When wiring the unit using a cable longer than the standard 1-meter cable equipped to the non-terminal box model, use shielded cables for signal line, or install signal cables in a separate duct/pipe from power supply cables.

LIGHTNING SURGE PROTECTION

- In order to protect the unit from lightning surges entering through cables, use of appropriate lightning surge protectors are recommended. For 24V DC power supply line, choose a surge protector with its maximum surge voltage 40V or less between lines.
 Recommended M-System model: MDP-D24.

PID CONTROLLER

- Choose PID parameters carefully so that the MV remains as stable as possible. Unstable control shortens the life of actuator and valve.

O-RING, PACKING

- When replacing the actuator cover after adjustments, check that the O-ring is securely placed in the groove.
- When replacing the terminal box cover, check that the packing is properly applied.

■ YOKE DESIGN

- When a foreign object is caught in the valve, a thrust 4 times greater than the maximum rating could be generated. Leave enough strength for mechanical components such as the yoke and the valve stem.
- If the MSP is used in an application such as temperature control of a steam line, the temperature can rise higher than the ambient temperature due to heat conducted or radiated from the piping even when the ambient temperature is within an allowable range.
Use a longer yoke to increase heat dissipation and apply insulating material.

■ AND

- DO NOT loosen the screw fixing the potentiometer lever. Loosening it could cause a malfunction.
- DO NOT step onto the actuator.
- DO NOT allow a heavy object to rest on or against the actuator.

PROTECTIVE FUNCTIONS**■ OVERLOAD (LOCK) PROTECTION**

The MSP is equipped with a protection circuit against overload caused by, for example, valve catching an alien substance.

When an overload is detected, the MSP stops supplying power to the motor and the status LED blinks at 0.5 sec. intervals.

The protection can be reset by applying an input signal to move the output stem in the opposite direction, or turning power off and restarting.

If the overload (lock) protection is activated too often, check for the presence of foreign matter in the valve, inappropriate adjustments, excessive tightening of the valve gland, or other possible causes of the overload.

Be sure to remove the cause of overload in order to avoid shortening the life of the product.

■ FUSE

A fuse is equipped for protection against overload current. Ensure that the power LED turns on as the power supply is turned on. If the power LED remains off, check to see if the fuse is melted. Replace the melted fuse with a new one. If the new fuse is melted again soon after replacement, there may be problems with the control PCB or the motor. Consult M-System or sales representative.

■ RESTARTING TIMER

The MSP is equipped with a timer circuit for setting a time interval (0 – 10 sec.) between stop-restart actions to prevent the motor and other internal components from overheating. It is recommended to set the restarting timer longer when the ambient temperature and/or the temperature of flow material is high.

The restarting timer is factory-set to 1.5 sec.

COMPONENT IDENTIFICATION

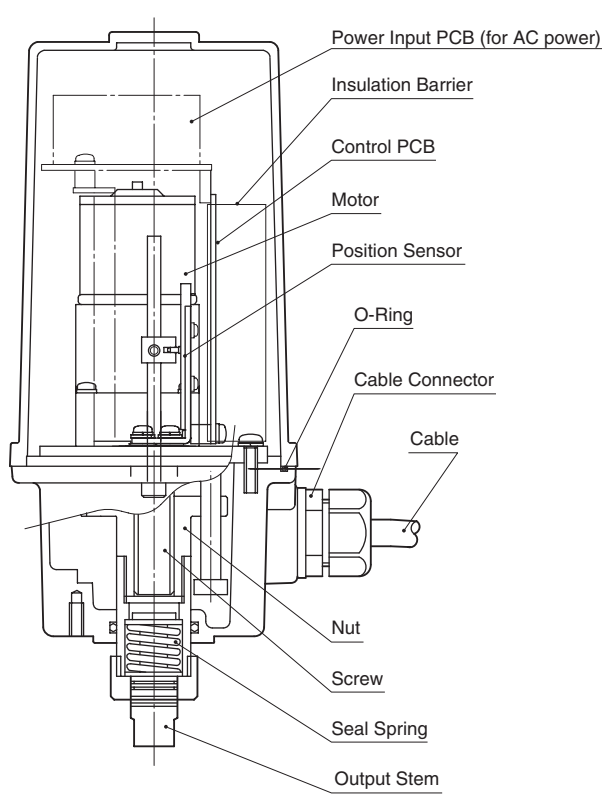

Figure 1. MSP4 & MSP5 Component Identification

Note: Construction of the MSP4 is partly different from the above figure.

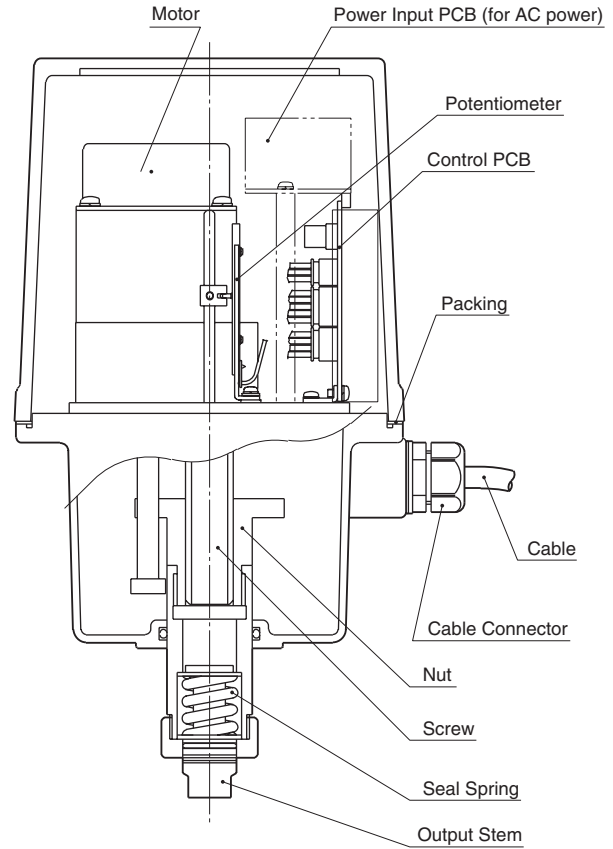

Figure 2-1. MSP6 Component Identification

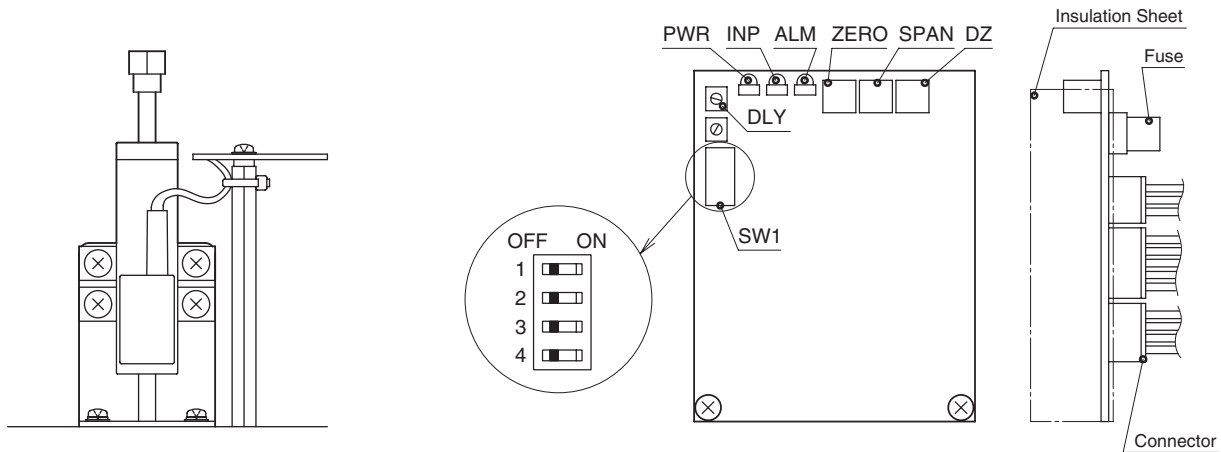

Figure 2-2. Long-life Potentiometer (MSP6)

- ZERO : Zero Adjustment
- SPAN : Span Adjustment
- DZ : Deadband Adjustment
- DLY : Restarting Timer
- SW1 : Direct/Reverse Actions,
Operation at Abnormally Low Input
- PWR : Power Indicator (Green LED is ON while power is supplied)
- INP : Input Indicator (Green LED is ON while normal signal is input)
- ALM : Status Indicator
(Red LED blinks at intervals of: 2 sec. in normal operation; and
0.5 sec. when an overload (lock) is detected)

Figure 3. MSP Control PCB Identification

Note: DO NOT manipulate the adjusters with a torque exceeding their tolerance, or it may destroy their stoppers.
Turn them carefully and stop where they hit the stoppers.
Pay extra attention when manipulating the Restarting timer adjuster.

OUTPUT STEM POSITION ADJUSTABILITY

The control PCB compares and amplifies input signal (set-point) and position feedback signal from the potentiometer, and drives the motor to such a direction that the difference of the two signals is minimized.

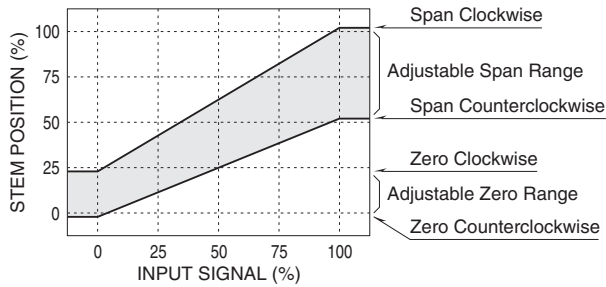

Figure 4. I/O Characteristics (Adjustable Range)

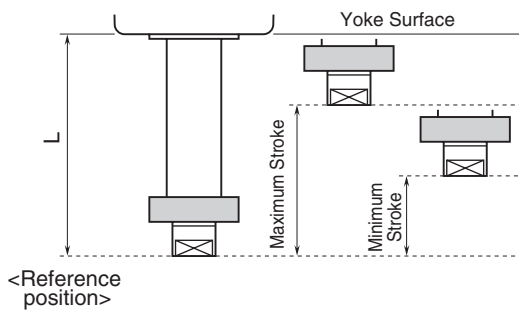

Figure 5. Minimum & Maximum Stroke

Table 1. Available Stroke Range for Each Model

MODEL	L	MIN. STROKE	MAX. STROKE
MSP4-1	29	5	10
MSP4-2	34	8	15
MSP5-1	40	5	10
MSP5-3	50	10	20
MSP6-3	58	10	20
MSP6-4	78	20	40

MANUAL OPERATION FUNCTION

(for MSP4 & MSP5)

- 1) Be sure to turn OFF the power voltage.
Operation with power voltage being applied may result in electrical shock or system breakdown.
- 2) Remove the screw cap on the top surface of the cover using a 22- mm wrench, etc.
- 3) Insert the attached hexagon key wrench in the manual drive shaft as shown in the figure below.
- 4) The wrench turning direction and the stem operation direction when seen from above differ according to the model as shown in the table below.

MODEL	NO. OF TURNS / OPERATION DISTANCE [turns/mm]	TURNING DIRECTION / OPERATION DIRECTION
MSP4-x3 MSP5-x3	27 / mm	CCW / GO DOWN
MSP4-x4 MSP5-x4	54 / mm	CCW / GO UP
MSP4-x7 MSP5-x7	112 / mm	CCW / GO DOWN

- 5) Tighten the cap on the cover with a torque of 4 to 6 N·m.
Tightening with an excessive torque may damage the screw thread of the cap.

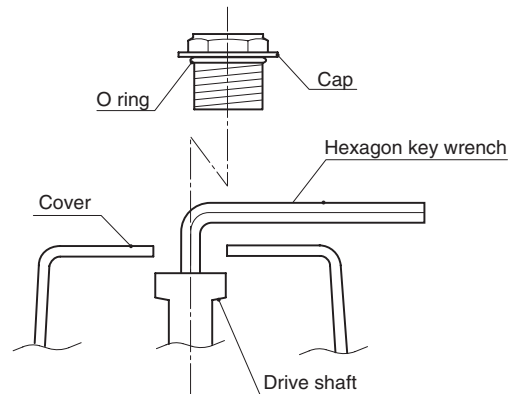

Figure 6. Manual Drive Shaft

INSTALLATION

The following is an example of procedure for mounting the MSP unit to a bi-directional valve.

The valve and components such as yoke necessary for the installation are to be provided by the customer. Be sure to remove power supply except when needed.

- 1) Supply power voltage to the MSP and apply 0% (100% for direct action) input signal to move the output stem to its fully extended position.
- 2) Set the valve stem at its lowest position.
- 3) Attach the yoke to the MSP.
- 4) Screw the valve stem into the output stem until there is little opening between them. For applying a sealing pressure, refer to Table 4 and screw it until the opening equals the contraction (e.g. 0.5 mm for MSP4-x3) that corresponds to the sealing pressure.
- 5) Fix the both stems with a lock nut.
- 6) Supply power voltage to the MSP and apply approx. 50% input signal, and ensure that the gap between the yoke and the valve bonnet has been closed. Fix the yoke and the valve.
- 7) Connect the position indicator and other components as needed.

Note: When mounting an MSP6 unit (24V AC model) using M-Systems's yoke set (model:YSS, for Japan sales only), refer to Instruction Manual (NM-4893) of the yoke set for the installation procedure.

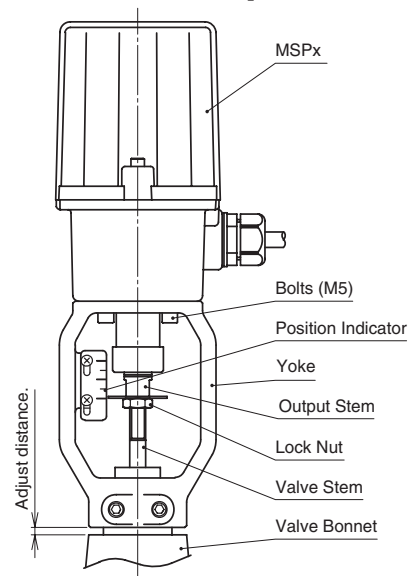
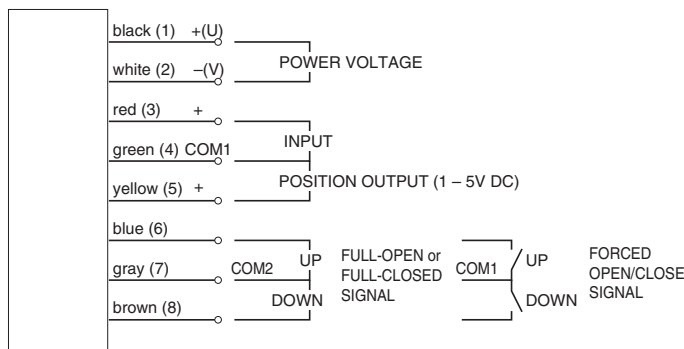

Figure 7. Example of the MSP Mounted to a Valve

WIRING CONNECTION

Refer to the following diagram when wiring.

If an optional terminal box is provided, remove its cover and connect leadwires.



NOTE

- (1) to (8): Terminal No. of terminal box.
- Full-open/-closed signals and forced open/close signals are optional.

Figure 8. Wiring Diagram

■ With Both Full-open/closed Signal and Forced Open/Close Signal

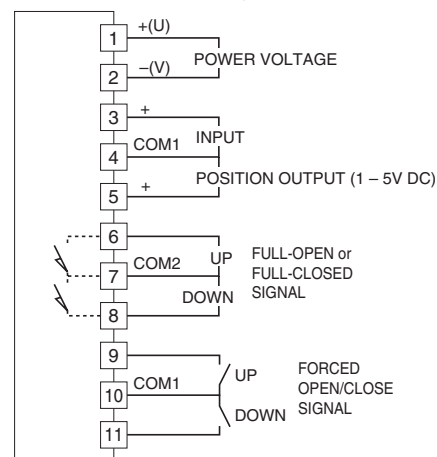

Note 1: The yellow wire must be left unconnected if the position output signal is not required.

Cut the exposed section of copper wire and insulate the tip of the wire.

Note 2: The MSP6 is not provided with full-open/-closed signals.

■ WIRING INSTRUCTIONS FOR TERMINAL BOX OPTION

• Sequential Control Signal Suffix Code B

Applicable wire size 1.25 mm²
Remove insulation by 10 mm.

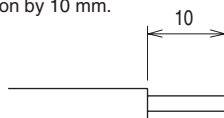

• Other Terminal Box Type

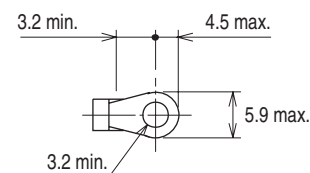

ADJUSTMENT PROCEDURE

Remove the cover.

Manipulate ZERO, SPAN, DZ (deadband), and DLY (Restarting timer) adjusters and the direct/reverse SW on the control PCB shown in Figure 3.

Other adjusters which are paint-sealed are for factory use only and should be changed only by qualified M-System personnel. Otherwise it could cause breakdown. M-System is not liable for any malfunction or inconvenience caused by unauthorized changes made by the user.

■ DIRECT/REVERSE ACTION AND OPERATION AT ABNORMALLY LOW INPUT

The actuator action is factory set to “Reverse” (i.e. the output stem goes up as the input signal increases.), and the operation at abnormality to “Go down.”

For changing the setting, use the DIP SW on the control PCB referring to Tables 2 and 3.

Table 2. Switching Actions

ACTION	SW1-3	EXPLANATIONS
Direct	ON	Output stem goes up as the input signal decreases. (Valve stem extended)
Reverse	OFF	Output stem goes down as the input signal decreases. (Valve stem retracted)

Table 3. Operations at Abnormally Low Input

OPERATION	SW1-1	SW1-2
Stop	– *1	ON
Go down/Extend	OFF	OFF
Go up/Retract	ON	OFF

*1. The setting of SW1-1 is disregarded in Stop mode.

Note 1: SW1-4 is not used.

Note 2: In ‘Direct’ action, the position output is 5 – 1V DC proportional to the input 0 – 100%.

■ ORDER OF ADJUSTMENTS

After installation, perform adjustments in the order of: zero; span; seal-spring; and sensitivity (deadband). Lastly, adjust the limit switches for optional full-open and full-closed signals.

The following explanation applies to ‘Reverse’ action. For ‘Direct’ action, read the values in the brackets [].

Note: Applying an over-torque to the adjusters may damage the threads or destroy stoppers. Use a small-sized screwdriver and be sure to stop turning as soon as they hit the stoppers.

■ ADJUSTMENT PROCEDURE

A) Zero and Span

- Supply power voltage to the MSP and apply 0% [100%] input. Turn Zero adjuster to adjust the lower-end or fully-extended position of the output stem (valve stem retracted) to a desired position. Alternatively, adjust the connecting section of the stems. For applying a sealing pressure, refer to Table 4 and screw it until the opening equals the contraction that corresponds to the sealing pressure.
- While applying 100% [0%] input, turn the Span adjuster until the output stem reaches a desired upper-end or fully-retracted position (valve stem extended). For three-way valves, the sealing pressure can be applied also in the direction in which the output stem goes up*2. Refer to the procedure for Zero adjustment.
- While applying 0% [100%] input again, check that the output stem reaches the fully-extended position. If the position is shifted, go through the above procedure again.

Note 1: The MSP is designed so as to minimize an influence of Span adjustment on the Zero position.

That is, the lower-end position of the output stem is hardly displaced when Span adjuster is manipulated.

Note 2: Narrower stroke is more likely to cause hunting i.e. the motor frequently changes rotation direction. Adjust Deadband in such a case.

*2. MSP4 is not provided with a sealing spring for the direction in which the output stem goes up.

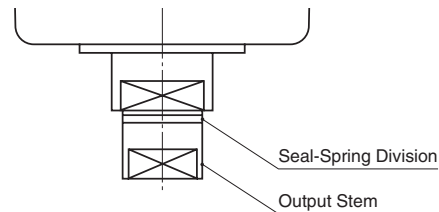

Figure 9. Seal-Spring

Table 4. Spring Contraction

MODEL	SPRING CONTRACTION (mm)	SEALING PRESSURE (N / lbs)	SET LOAD * (N / lbs)
MSP4-x3	0.5	147 / 33	98 / 22
MSP4-x4	1.0	300 / 67	250 / 56
MSP4-x7	1.0	686 / 154	294 / 66
MSP5-x3	0.5	150 / 34	110 / 25
MSP5-x4	1.0	294 / 66	216 / 49
MSP5-x7	1.0	686 / 154	294 / 66
MSP6-x3	1.0	588 / 132	441 / 99
MSP6-x4	1.0	1170 / 263	882 / 198
MSP6-x6	1.5	2350 / 529	1170 / 263

* The pre-set load for applying a minimum pressure to seal the valve when the valve sits on the seat.

Note: The output stem is provided with a scale in millimeters. In case of MSP4-x7, for example, the sealing pressure reaches approx. 490 N at 0.5 mm and 686 N at 1 mm.

B) Sensitivity (Deadband)

There may be a case where the motor operates in response to an input signal change but does not stop and oscillates by frequently changing the rotation direction. Widen the deadband by turning DZ adjuster clockwise in such a case. The deadband is factory-set to 1.5 %.

C) Limit Switches (for optional full-open and full-closed signals) *

Loosen the screws and adjust positions of the dogs. Each dog cannot be set at an intermediate position. Be sure to set the dog at the fully-open or closed-position. See Figure 9.

Note: Not available when the long-life potentiometer option (/P) is selected.

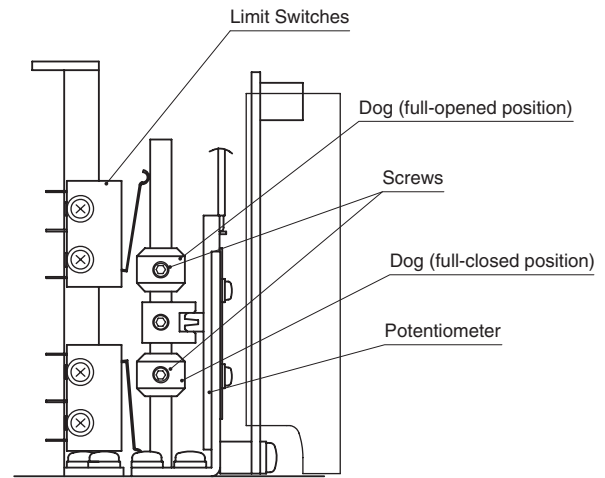

Figure 10. Limit Switches

MAINTENANCE

For effective use and longer life of the MSP, regular checking appropriate for its operating conditions are recommended. Refer to the following table.

■ INSPECTION

ITEM	CHECKING POINT	HOW TO PROCEED
Stem operation	Apply input 0%, 50%, 100%, then back to 50%, 0%. Check that the actuator operates and positions correctly at each input value.	Repair or calibrate the unit.
Abnormal sound	Check if abnormal sound is heard during operation.	Repair the unit.
Connector Leadwire	Ensure that the connector is firmly connected. Check for breakage of leadwires. Ensure that the insulation coating is not broken or damaged.	Repair or replace the connector/leadwires.
Water or rust inside the housing	Check that there is no water or rust inside the housing. Check that the gasket is not damaged. Check that the cable connector is not loose.	Remove water, dry the housing and the parts inside. Replace rusted parts, if any. Replace the gasket, if damaged. Re-tighten the cable connector.
Screws	Check that screws and bolts are securely fastened.	Re-tighten them, if loose.
Lock nut	Check that the Lock nut is not loose.	Re-tighten the Lock nut if loose and calibrate the unit.

For repair or parts replacement, contact M-System or representatives.

■ LUBRICATION

There is no need of oiling the MSP in normal operating conditions.

■ REGULAR TEST RUNNING

If the valve is not frequently operated, run a test operation regularly (once a week, for example) to ensure that the actuator operates properly.

TROUBLESHOOTING

TROUBLE	POWER LED	INPUT LED	STATUS LED	POSSIBLE CAUSE	HOW TO PROCEED
Actuator does not work	ON	ON	Blink 2 sec. intervals	Abnormal input signal. (No change over deadband)	Check input signal. Narrow the deadband.
	ON	---- *	Blink 0.5 sec. intervals	Actuator mechanism is damaged.	Repair the unit.
				Overload caused by a foreign object caught in the valve.	Check the valve.
				Control PCB damaged.	Repair or replace the PCB.
				Wiring error at the motor or position sensor.	Check the connector.
				Low power voltage or insufficient power supply.	Check the power supply.
	ON	OFF	Blink 2 sec. intervals	Abnormal input signal.	Check the input signal.
				Wiring error at the input signal.	Check the connector and connecting section.
	OFF	---- *	---- *	Wiring error at the power supply.	Check the connector and connecting section.
				Abnormal power voltage.	Check the power supply.
				Fuse melted.	Replace the fuse.
	ON	---- *	ON	Malfunction by noise.	Turn off the power supply and restart.
Low power voltage or insufficient power supply.				Check the power supply.	
ON	---- *	OFF	Malfunction by noise.	Turn off the power supply and restart.	
			Low power voltage or insufficient power supply.	Check the power supply.	
Unstable operation				Power voltage is low or fluctuating.	Check the power supply.
				Unstable input signal.	Check the controller, cables. Eliminate noise.
				Position sensor (potentiometer) damaged.	Replace the potentiometer.
Stem stops in the middle of stroke or Stem slows down in the middle of stroke				Actuator mechanism is damaged.	Repair the unit.
				Overload caused by a foreign object caught in the valve.	Check the valve.

* The input LED status does not matter.

For repair or parts replacement, consult M-System or representatives.

LIGHTNING SURGE PROTECTION

M-System offers a series of lightning surge protectors for protection against induced lightning surges. Please consult M-System for appropriate models.