

LIGHTNING SURGE PROTECTOR FOR ISDN CIRCUIT USE

MODEL MD-INS

BEFORE USE

Thank you for choosing M-System. Before use, check the package you received as below. If you have any problems or questions on the product, please contact M-System's Sales Office or representatives.

PACKAGE INCLUDES:

Lightning surge protector (body + base socket)..... (1)

MODEL NO.

Confirm that the model number described on the product is exactly what you ordered.

INSTALLATION / INSTRUCTION MANUAL

This manual describes necessary points of caution when you use this product, installation, and basic maintenance procedure.

LIMITATION APPLICABLE TO M-RESTER

The M-Rester will protect electronics equipment from damage caused by lightning by absorbing most of the surge voltages.

However, M-Rester may not be effective against certain extremely high voltages caused by a direct or almost direct hit by lightning.

M-Rester must be installed according to this installation / instruction manual.

POINTS OF CAUTION

GENERAL

- Before you remove the body from its base socket or mount it, or connect/disconnect leadwires to the M-RESTER, turn off the input signal to the M-RESTER and power supply for peripheral devices for safety.
- DO NOT DO any maintenance work for the M-RESTER during thunder storms.

ENVIRONMENT

- When heavy dust or metal particles are present in the atmosphere, install M-RESTER inside proper housing and ventilate it.
- Do not install the M-RESTER where it is subjected to continuous vibration. Do not apply physical impact to the M-RESTER.
- Environmental temperature must be within -5 to +55°C (23 to 131°F) and relative humidity within 30 to 90% RH in order to ensure adequate life span and operation.
- Altitude up to 2000 meters

INSULATION TEST

- The maximum applicable voltage for testing insulation between ISDN circuit and the housing is 250V DC. If a greater voltage is applied, the element will start discharging at discharge voltage, which can cause insulation failure or loss of dielectric strength.

If a greater voltage must be applied, remove the element body from the base socket, close across its terminals 5 - 3 and 6 - 4, before conducting a test.

Be sure to open these terminals again and return the body after the test.

AND

- We recommend that you keep spare M-RESTERs so that you can replace them when necessary.
- Lightning surge can enter not only through signal lines but also through power supply lines. We recommend that you also use the Lightning Arrester for Power Lines for sufficient protection.

GENERAL

FUNCTION & FEATURES

- Designed specifically for ISDN circuit

SPECIFICATIONS

	BETWEEN LINES	LINE TO GND
Discharge voltage	±65V min	±290V min.
Max. surge voltage*	±100V max.	±650V max.
Leakage current	≤50µA @±65V DC	≤50µA @±140V DC
Maximum line voltage	±65V	
Response time	≤0.1 µsec.	
Discharge current (8 / 20 µsec.)	500A for modular jack connection 10000A for screw terminal connection	
Maximum load current	100mA	
Internal series resist.	approx. 4Ω including return	

*The maximum voltage that could pass through M-RESTER. Protected equipment must be able to withstand this voltage for a very short time period.

COMPONENT IDENTIFICATION

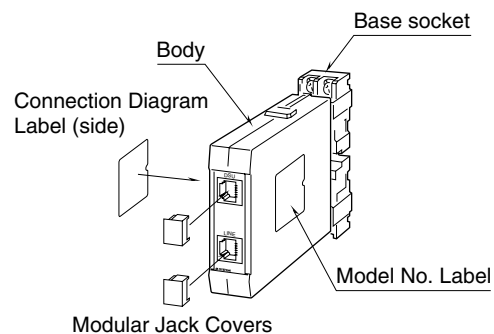

■ FRONT PANEL CONFIGURATION

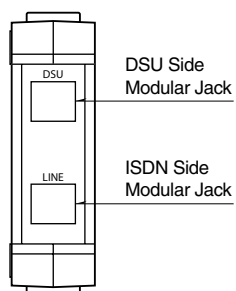

INSTALLATION

Pull out the body in pressing the clamps located at the top and bottom of the unit for separating it from the base socket.

■ DIN RAIL MOUNTING

Set the base socket so that its DIN rail adapter is at the bottom. Hung the upper hook at the rear side of base socket on the DIN rail and push in the lower. When removing the socket, push down the DIN rail adapter utilizing screwdriver (→) and pull.

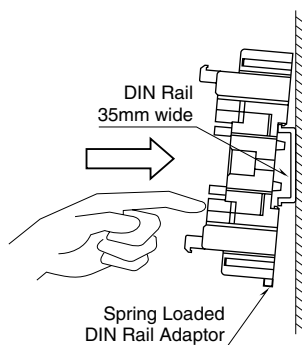

■ WALL MOUNTING

Refer to the drawings in the figure below.

EXTERNAL DIMENSIONS mm [inch]

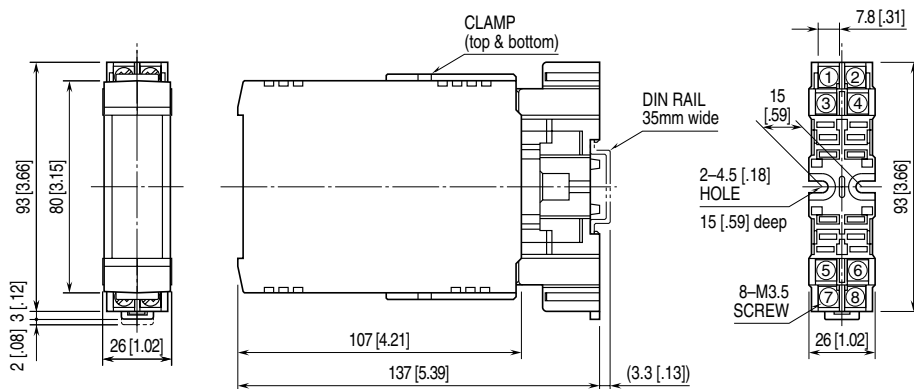

•When mounting, no extra space is needed between units.

TERMINAL CONNECTIONS

Connect the unit as in the diagram below.

Be sure to cross-wire between Ground terminal of the protected equipment and one of the ground terminals (G) of the MD-INS. When the protected device has no ground terminal such in the case of M-System products, ground only the one of the MD-INS. The MD-INS can be connected to ISDN circuit via modular jack ports or screw terminals. We recommend, however, to use the screw terminals because the MD-INS is capable of a discharge current up to 10000A (8/20 μ sec.) when it is connected via these terminals, while it is up to 500A (8/20 μ sec.) with modular jacks.

There is no difference in discharge current capacity at the DSU side by either means.

MODULAR JACK COVERS

Be sure to put modular jack covers when they are not used.

SCHEMATIC CIRCUITRY

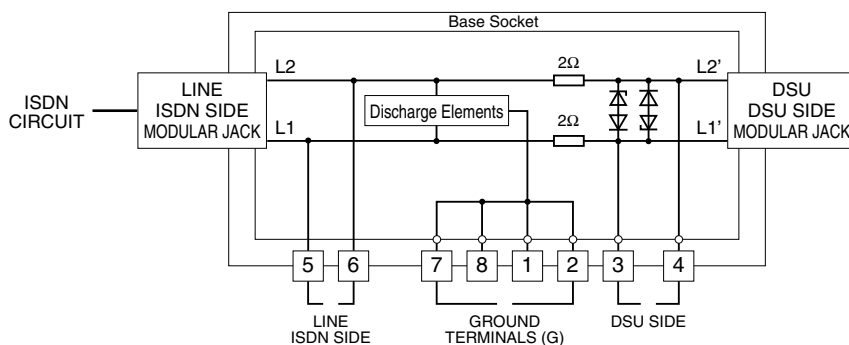

Be sure to cross-wire between the G terminal of telephone set and one of the terminals 7, 8, 1, or 2 of the MD-INS.

CONNECTION DIAGRAM

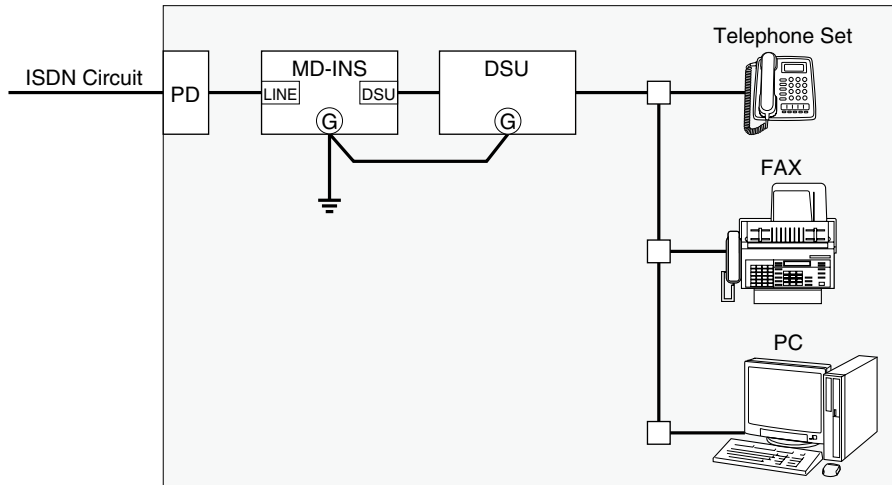

GROUNDING

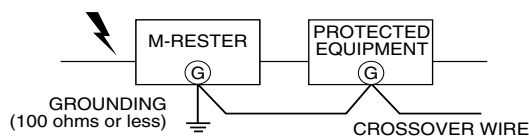

A crossover wire between M-RESTER ground and ground or metallic housing of equipment is required for protection. If the protected equipment has no ground terminal, ground the M-RESTER only.

MAINTENANCE

Check M-RESTER periodically. Many cases of lightning are ignored, and even lightning at a far distance often causes inductive surges.

We recommend that you check your M-RESTER about twice a year, before and after the rainy season. Check whenever you experience a strong lightning occurrence.

Checking procedure is explained in the following:

■ CHECKING

WIRING

- Make sure that the wires are connected as instructed in the connection diagram.
- Make sure that Ground terminal (G) is connected to the metallic housing of protected equipment.
- Make sure that Ground terminal (G) is grounded to earth.

ELEMENT MODULE

Remove all wiring connected to M-RESTER when you test the discharge elements.

- Check resistance across the following terminals on the high resistance range of multimeter and confirm no conduction. (The meter will indicate the same value as it will show when these terminals are open.)
Terminals (5) – (6), (5) – (7), (6) – (7)
- Check that discharging occurs across the same terminals with a 500V DC/1000M Ω megger. (The megger will show 20M Ω or less.)
- If any of the above tests shows negative, replace the M-RESTER.