

XUM5ALAYL2 / XUM5ALAYP015 / XUM5ALAYM8 (34 x 12 x 20)

Photo-electric sensors - Miniature design

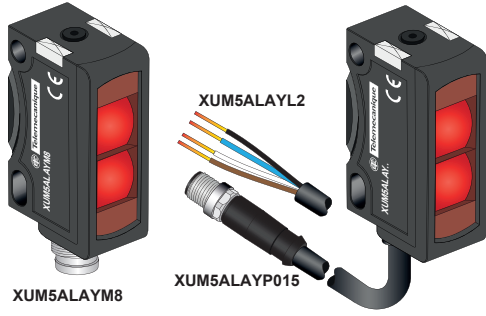

Contrast

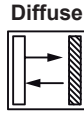

Package Content
(Example)

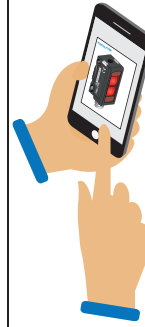
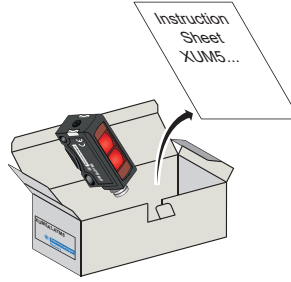

Scan the code to access this Instruction Sheet in different languages and all the product information or you can visit our website at: www.tesensors.com

We welcome your comments about this document. You can reach us through the customer support page on your local website.



DANGER

HAZARD OF ELECTRIC SHOCK, EXPLOSION OR ARC FLASH

- Disconnect all power before servicing equipment.
- Do not connect this device to AC power.
- The power voltage must not exceed the rated range.

Failure to follow these instructions will result in death or serious injury.

WARNING

IMPROPER SETUP OR INSTALLATION

- This equipment must only be installed and serviced by qualified personnel.
 - Read, understand, and follow the compliance below, before installing the XU Photo-electric sensor.
 - Do not tamper with or make alterations on the unit.
 - Comply with the wiring and mounting instructions.
 - Check the connections and fastening during maintenance operations.
 - The proper functioning of the XU Photo-electric sensor and its operating line must be checked regularly and according to the application (for example number of operations, level of environmental pollution, etc.).
- Failure to follow these instructions can result in death, serious injury, or equipment damage.

Mounting and tightening torques

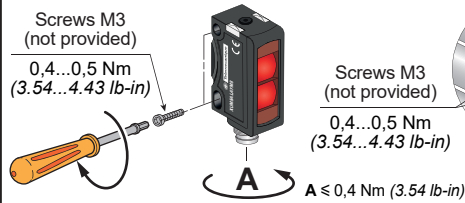

CAUTION

DEGREE OF PROTECTION DETERIORATION
Do not apply excessive torque on the sensor during the installation process.
Failure to follow these instructions can result in injury or equipment damage.

LEDs and settings

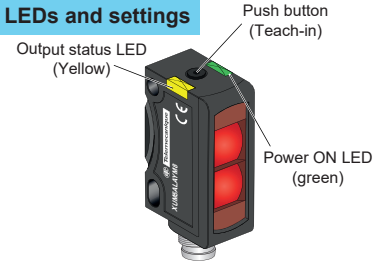

Wiring diagrams

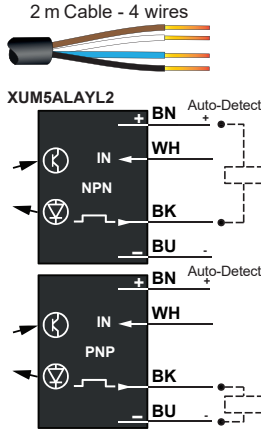
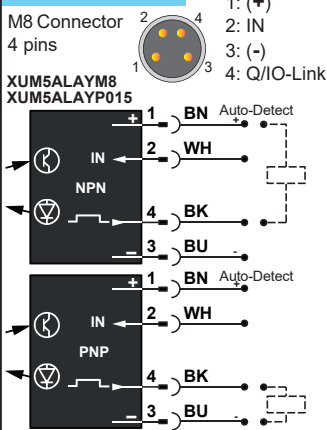

Remote teach-in

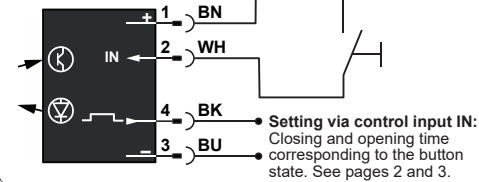

CAUTION

INOPERABLE EQUIPMENT DUE TO CYBER ATTACK ON IO-LINK

- Apply external cybersecurity protection on IO-Link Master device.
- Download IO-Link Description files only from these web servers:
<https://tesensors.com/global/en/support/iolink> or
<https://ioddfinder.io-link.com/#/>

Failure to follow these instructions can result in injury or equipment damage.

Pin	Wire	Signal	Definition
1	BN	+	+ 24 Vdc
2	WH	IN	+ = NO - = NC Open = NO
3	BU	-	0 Vdc
4	BK	Q	Switching signal (SIO)
		C	Communication IO-Link

IO-Link data tables and IODD files are online:
Scan the 2D code, above

IO-Link

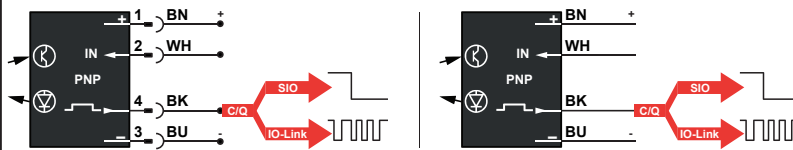

Switching Mode for object

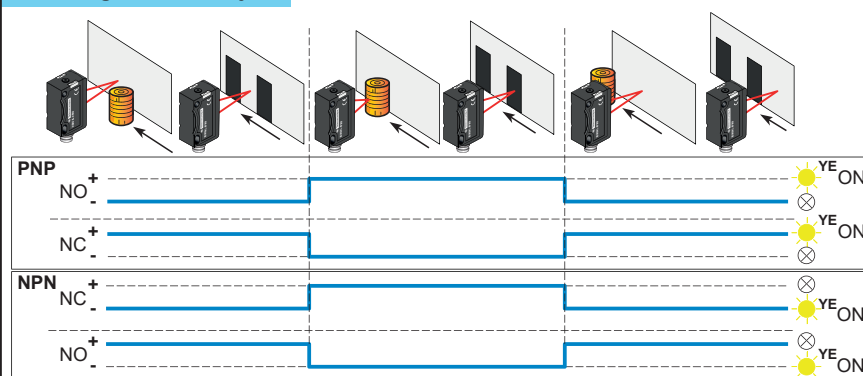

Alignment - Distance Orientation

Maximum angle tolerance

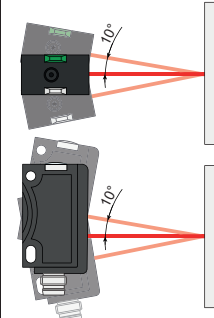

Mounting, wiring and maintenance precautions

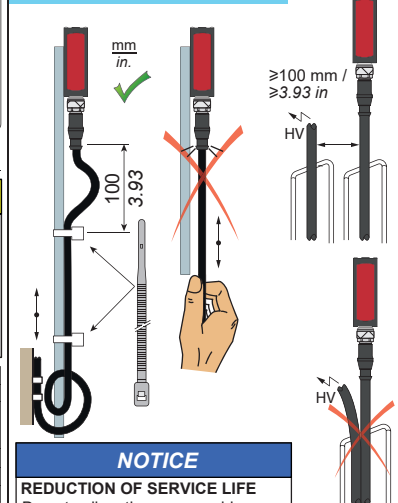

NOTICE

REDUCTION OF SERVICE LIFE
Do not pull on the sensor cable.
Failure to follow these instructions can result in equipment damage.

Electrical equipment should be installed, operated and maintained only by qualified personnel. Neither TMSS France nor any of its subsidiaries or other affiliated companies shall be responsible or liable for any consequences arising out of the use of this material. Telemecanique™ Sensors is a trademark of Schneider Electric Industries SAS used under license by TMSS France. Any other brands or trademarks referred to in this document are property of TMSS France or, as the case may be, of its subsidiaries or other affiliated companies. All other brands are trademarks of their respective owners.

Manufacturer :
TMSS France
Tour Egho - 2 avenue Gambetta
92400 Courbevoie
France

UK Representative :
Yageo TMSS UK Limited
2 North Park Road
Harrogate, HG1 5PA
United Kingdom

XUM5ALAYL2 / XUM5ALAYP015 / XUM5ALAYM8 (34 x 12 x 20)

Dimensions

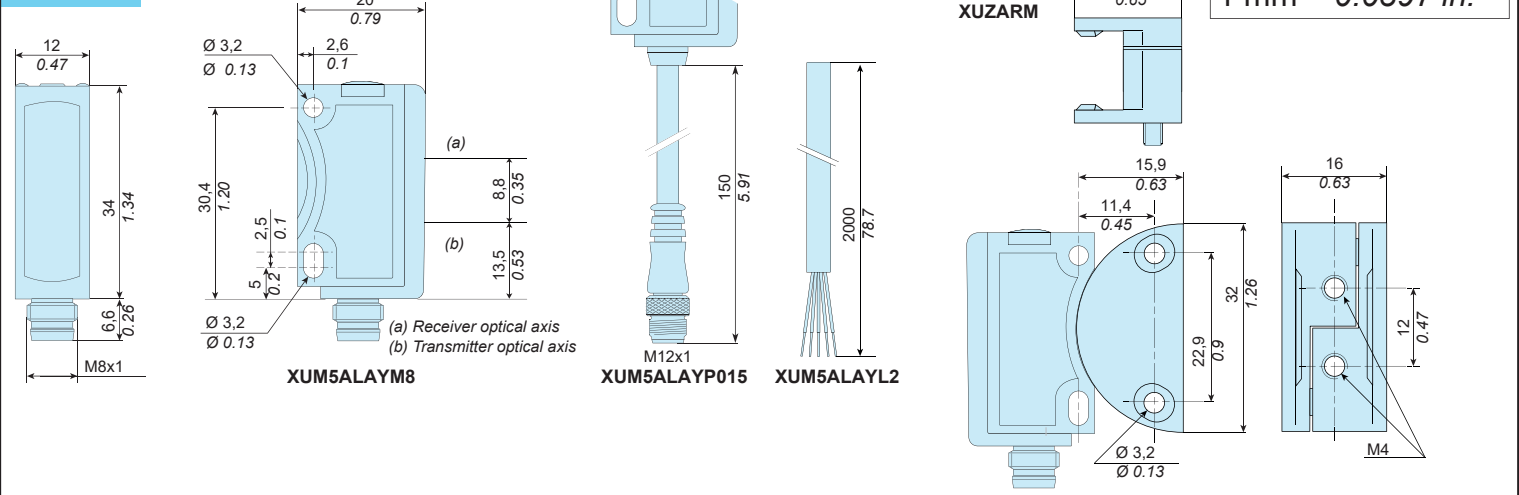

Accessories

Dovetail clamp mounting for flexible adjustment (to order separately)

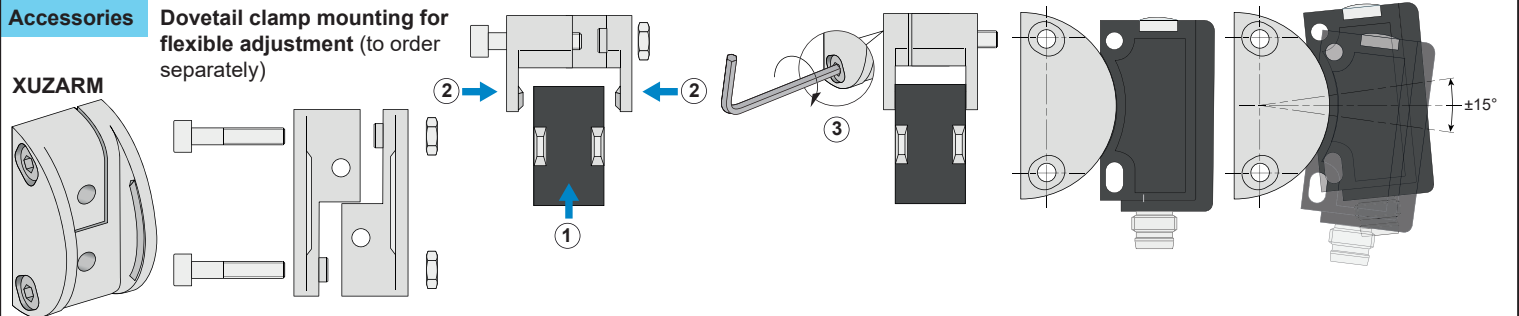

Pre-wired connectors (examples)

PVC cable for general use
PUR cable for severe industrial environments



XZCPB1141L2 2m PUR XZCR2711037T1 1m PUR XZCR2705037R1 1m PUR
XZCPB1141L5 5m PUR XZCR2711037T2 2m PUR XZCR2705037R2 2m PUR

For other cables (angled or length) visit our website: Tesensors.com

Curves

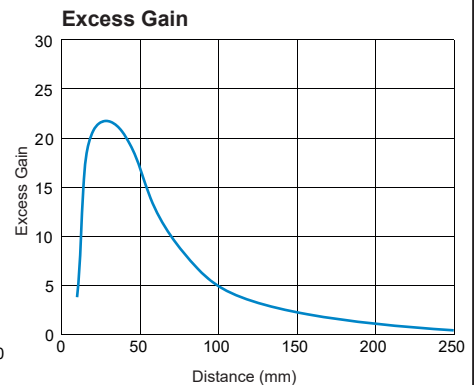
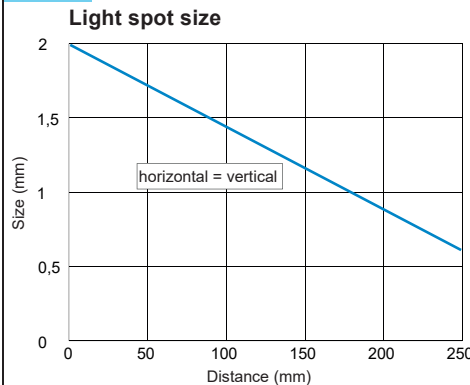

Setting

The sensor has 3 different Teach-in modes:

- A-Standard Teach-in (STI):** is suited for nearly all applications. Setting is made on object and background (see illustration A).
- B-Object-Object Teach-in (MTI or OTI):** is suited for applications where the background cannot be taught in. Setting is made 2x on the object (see illustration B).
- C-Dynamic Teach-in (DTI):** is suited for setting the sensor in the running process, particularly for small objects (see illustration C).

The sensor has 3 different **Switching NO/NC** settings:

- 1: NO/NC via teach-in in series
- 2: Sensor always NC
- 3: Sensor always NO

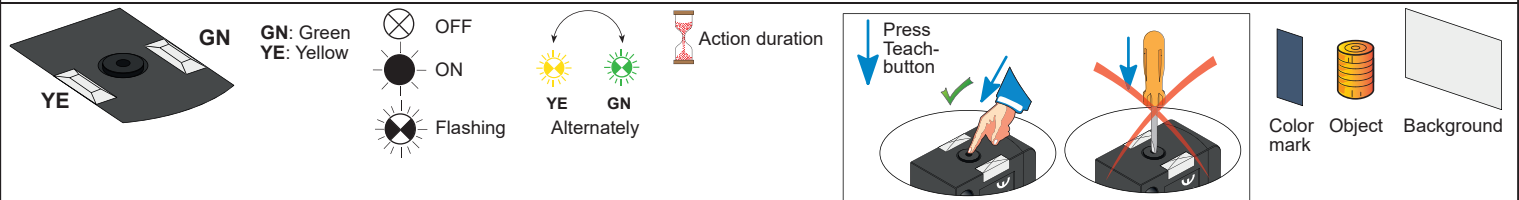

A Standard Teach-in (STI)

Step 1: Teach-in Mark or Object

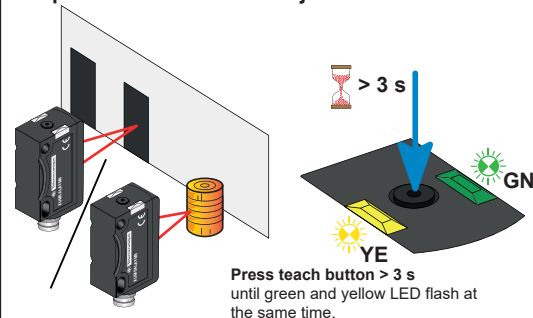

Step 2: Teach-in background

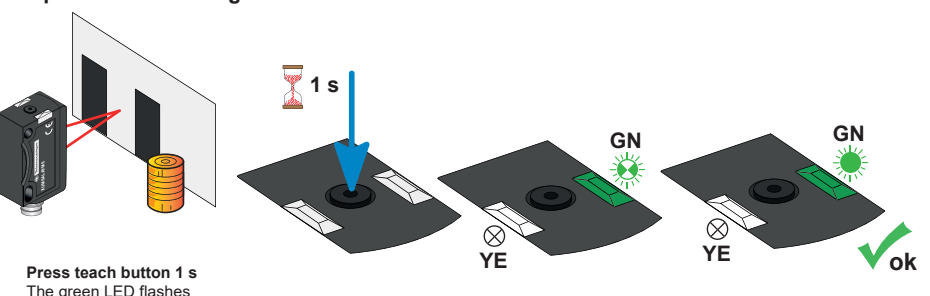

B Mark-Mark or Object-Object Teach-in (MTI or OTI)

Step 1: Teach-in Mark or Object

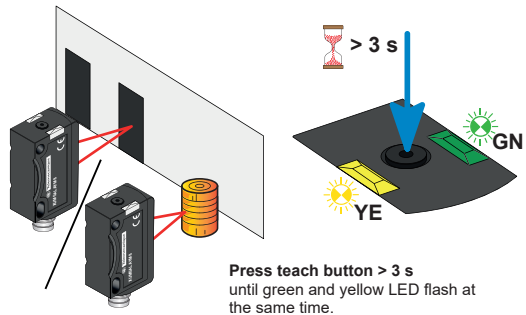

Step 2: Teach-in Mark or Object

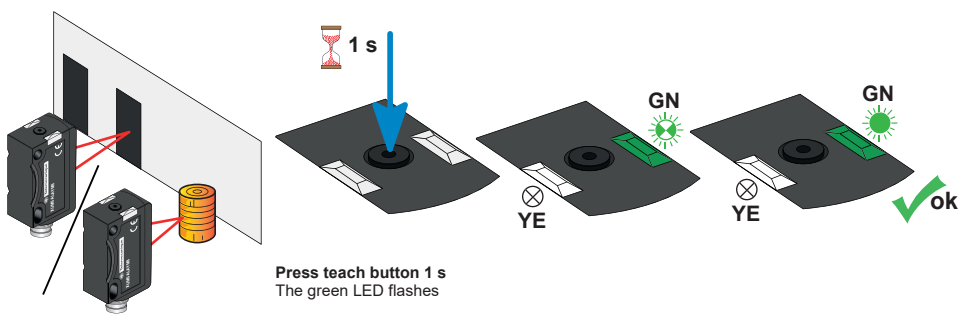

C Dynamic Teach-in (DTI)

Step 1: During running process

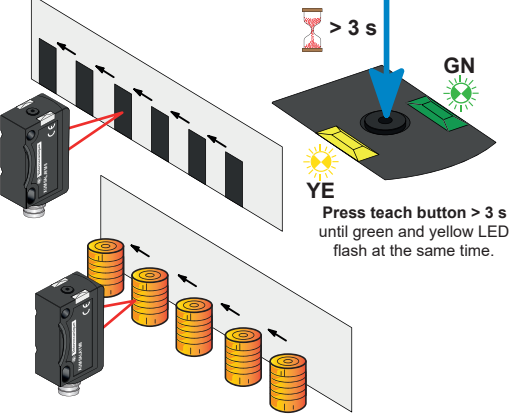

Step 2: Teach-in mark or object during running process

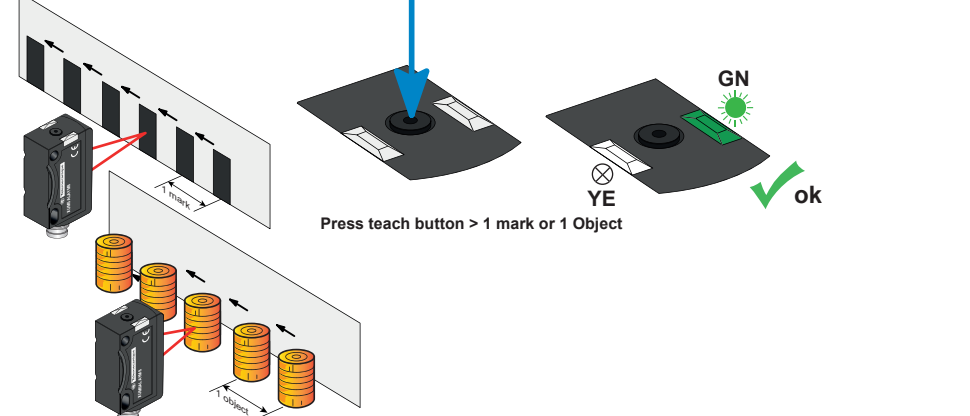

D Switching NO/NC

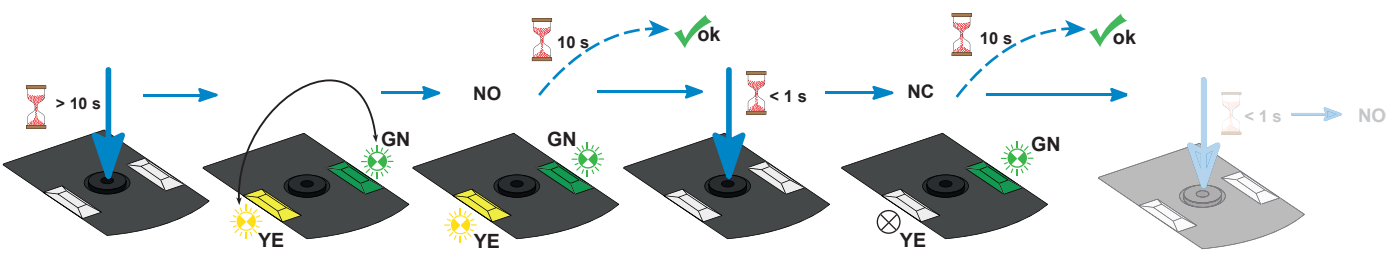

E Factory Setting

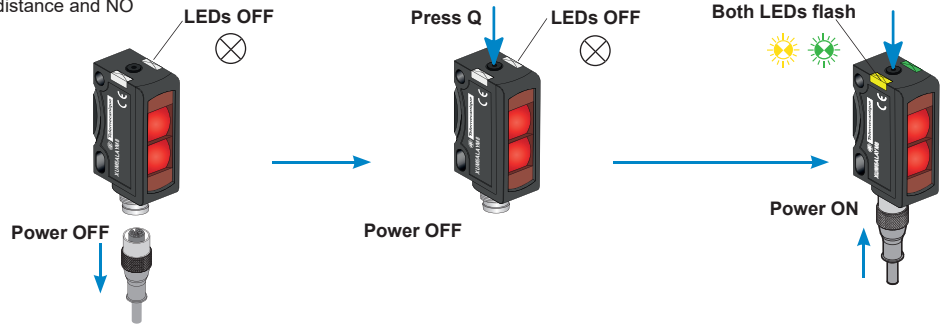

Max. scanning distance and NO



Press and hold any button and Power ON:
 → green and yellow LEDs flash simultaneously
Keep button pressed > 10 s:
 → green and yellow LEDs still flash simultaneously, but faster
 → sensor is set to factory settings

XUM5ALAYL2 / XUM5ALAYP015 / XUM5ALAYM8 (34 x 12 x 20)

Characteristics

Certification	CE - UKCA - cULus - Ecolab
Sensing distance	1...250 mm / 0.04...9.84 in. [Adjustment range: 25...250 mm / 0.98...9.84 in.]
Setting	Teach button
Detection light beam	Laser class 1, red, 650 nm
 Wavelength	$\lambda = 650 \text{ nm}$
Puls duration	$t = 0,7 \mu\text{s}$
Frequency	$f = 11,7 \text{ kHz}$
Limit of radiant power pulse	$P_p = 8,5 \text{ mW}$
Output function	NO/NC via Teach-in
Switching output Q	Auto-Detect - PNP/NPN (NO or NC) - IO-LINK
Control input IN (switching function Q):	(+) = Teach-in (-) =  button locked Open = normal function
Current consumption	$\leq 30 \text{ mA}$
Switching capacity	$\leq 100 \text{ mA}$
Switching frequency	$\leq 4000 \text{ Hz}$
First-up delay	$< 300\text{ms}$
Response time	$\leq 125 \mu\text{s}$
Recovery time	$< 300\text{ms}$
Ambient Temperature	Operating : $-20...+60 \text{ }^\circ\text{C}$ ($-4...+140 \text{ }^\circ\text{F}$) - UL : $-20...+50 \text{ }^\circ\text{C}$ ($-4...+122 \text{ }^\circ\text{F}$) Storage : $-20...+80 \text{ }^\circ\text{C}$ ($-4...+176 \text{ }^\circ\text{F}$)
Power Voltage	Rated operational voltage: 12...24 Vdc Operating range: 10...30 Vdc (including ripple p-p 10% maximum)
Product protection	Power supply : Reverse polarity protection Output: Short circuit protection
Protection against electric shocks	<input type="checkbox"/> Protection class II
Degree of protection	IP67 conforming to IEC 60529 , IP69K conforming to DIN 40050-9
Vibration resistance	Conforming to EN 60947-5-2
Shock resistance	Conforming to EN 60947-5-2
Material	Housing: ABS, Front and Lens: PMMA

