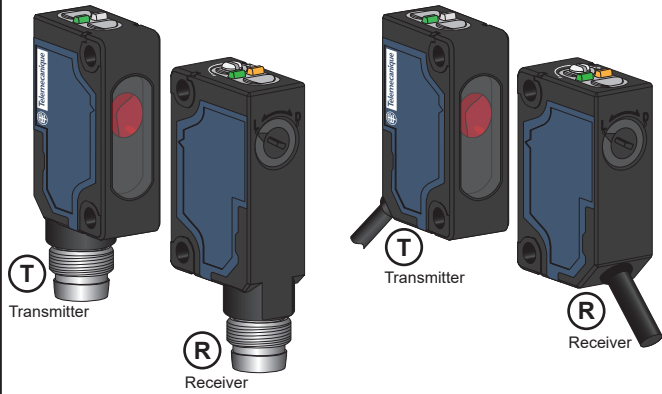
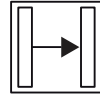

Photo-electric sensors - Miniature design



NPN - M8 Connector : XUM2ANXB8 (*)
 PNP - M8 Connector : XUM2APXB8 (*)
 NPN - 2 m Cable : XUM2ANXBL2 (*)
 PNP - 2 m Cable : XUM2APXBL2 (*)
 (*): Sold by pair (1 Transmitter + 1 Receiver)

Thru-beam



Package Content (Example)

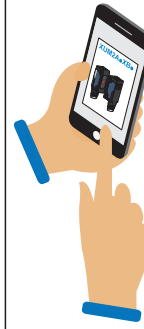
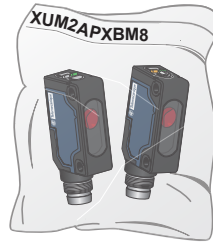

<http://qr.tesensors.com/XU0007>

Scan the QR-code to access this Instruction Sheet in different languages or you can download it from our website at: www.tesensors.com

We welcome your comments about this document. You can reach us through the customer support page on your local website.

⚠ DANGER

HAZARD OF ELECTRIC SHOCK, EXPLOSION OR ARC FLASH

- Disconnect all power before servicing equipment.
- Do not connect this device to AC power.
- The power voltage must not exceed the rated range.

Failure to follow these instructions will result in death or serious injury.

⚠ WARNING

IMPROPER SETUP OR INSTALLATION

- This equipment must only be installed and serviced by qualified personnel.
- Read, understand, and follow the compliance below, before installing the XUM Photo-electric sensor.
- Do not tamper with or make alterations on the unit.
- Comply with the wiring and mounting instructions.
- Check the connections and fastening during maintenance operations.
- The proper functioning of the XUM photoelectric sensor and its operating line must be checked regularly and according to the application (for example number of operations, level of environmental pollution, etc.).

Failure to follow these instructions can result in death, serious injury, or equipment damage.

Mounting and Tightening torques

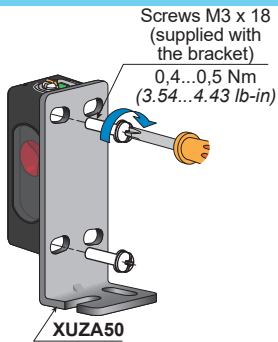

Screws M3 x 18 (supplied with the bracket)
 0,4...0,5 Nm
 (3.54...4.43 lb-in)

Screws M3 (not provided)
 0,4...0,5 Nm
 (3.54...4.43 lb-in)

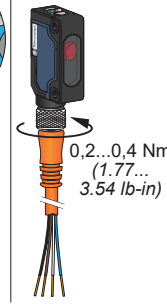
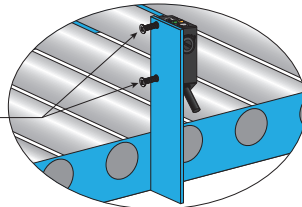

0,2...0,4 Nm
 (1.77...3.54 lb-in)

⚠ CAUTION

UNINTENDED EQUIPMENT OPERATION
 Do not apply excessive impact on the sensor during the installation process, so as to prevent damage or deterioration in the degree of protection.
 Failure to follow these instructions can result in injury or equipment damage.

LEDs and Setting

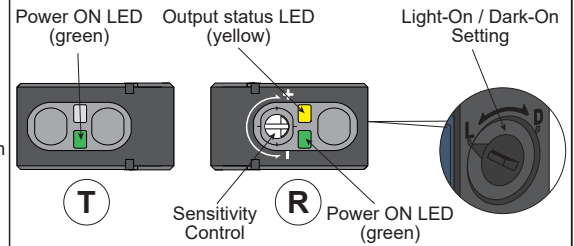

Power ON LED (green)

Output status LED (yellow)

Light-On / Dark-On Setting

T

R

Sensitivity Control

Power ON LED (green)

Wiring diagrams

M8 Connector - 4 pins

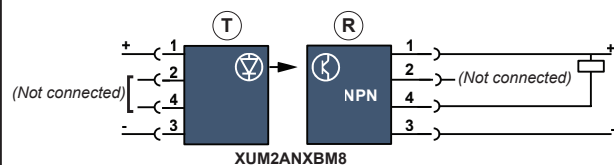
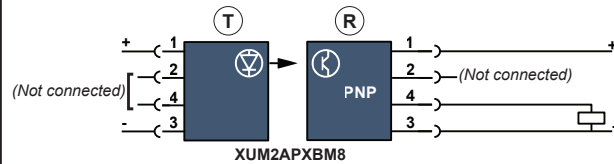
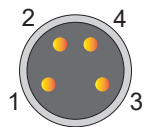

2 m Cable - 3 wires

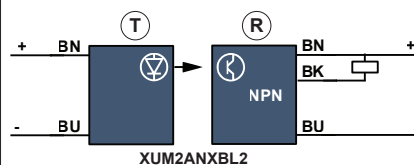
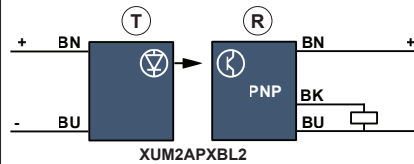

Wiring precaution

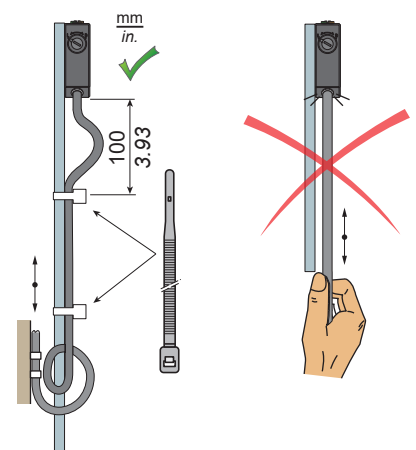

NOTICE
UNINTENDED EQUIPMENT OPERATION
 Do not pull on the sensor cable so as to prevent damage or deterioration in the degree of protection.
 Failure to follow these instructions can result in equipment damage.

Electrical equipment should be installed, operated and maintained only by qualified personnel.
 No responsibility is assumed by Schneider Electric for any consequences arising out of the use of this material.

© 2021 Schneider Electric. "All Rights Reserved."

Dimensions

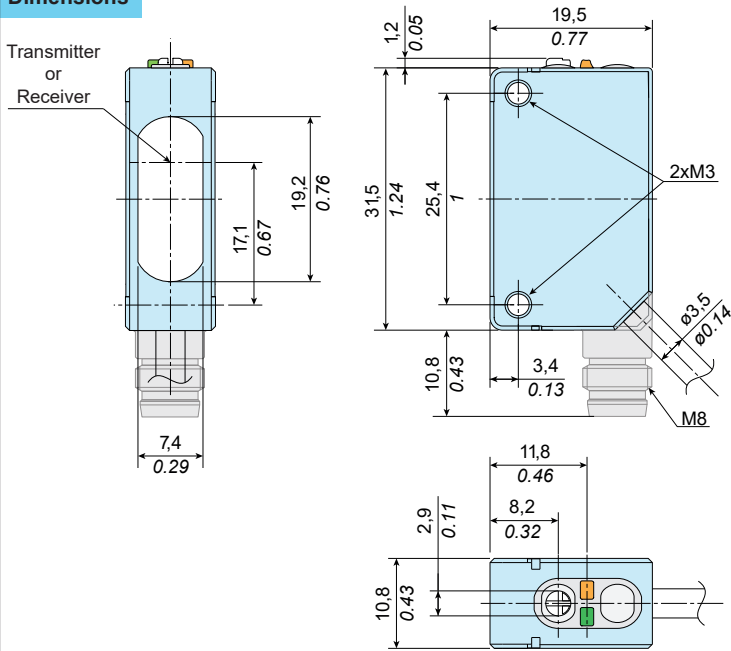

mm
in.

1 mm = 0.0397 in.

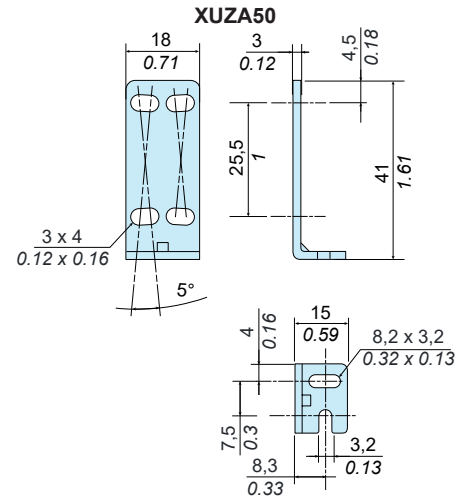

XUZASM04

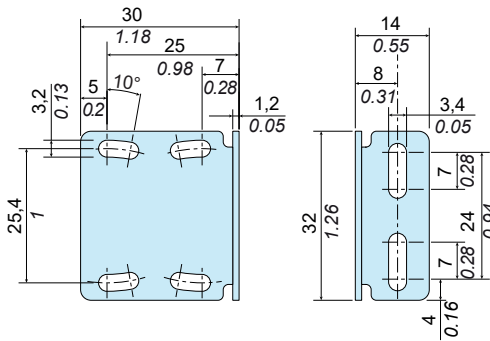

XUZASM02

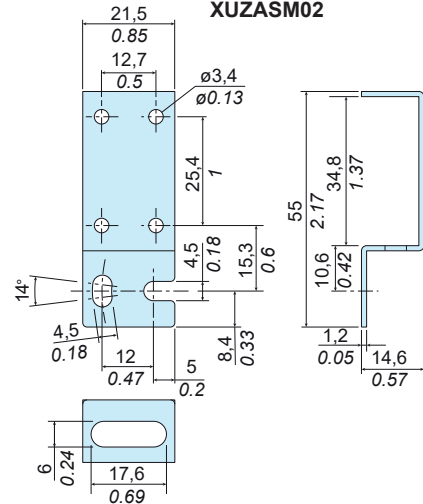

XUZASM03

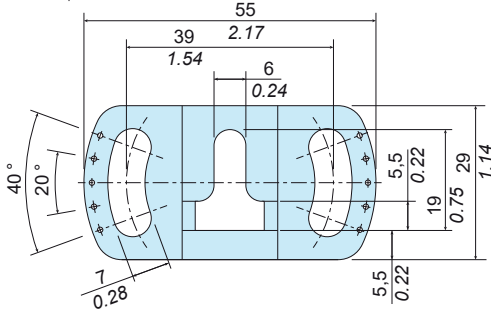
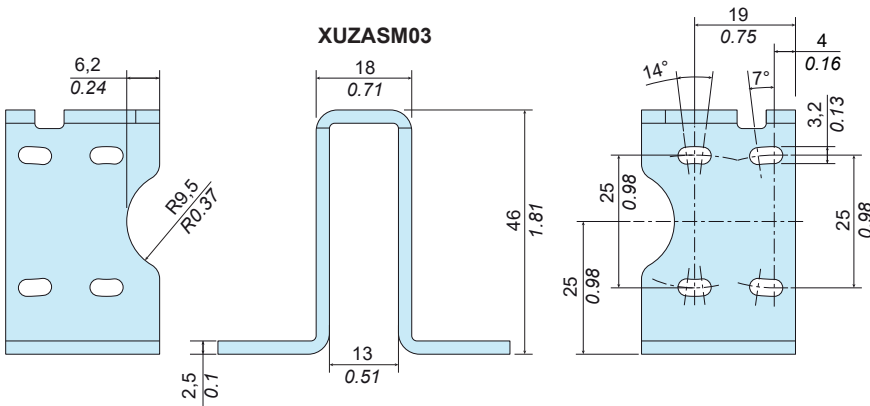

mm
in.

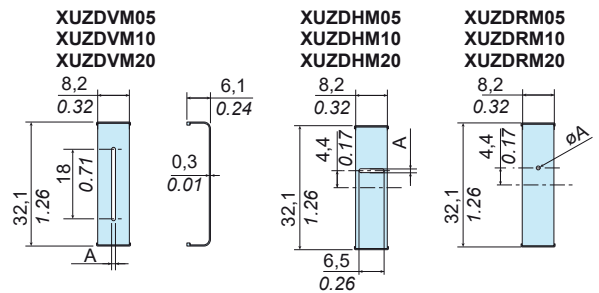

Width "A"	Vertical slit	Horizontal slit	Round slit	
mm	in.			
0,5	0.02	XUZDVM05	XUZDHM05	XUZDRM05
1	0.04	XUZDVM10	XUZDHM10	XUZDRM10
2	0.08	XUZDVM20	XUZDHM20	XUZDRM20

Accessories

Mounting brackets (to order separately)

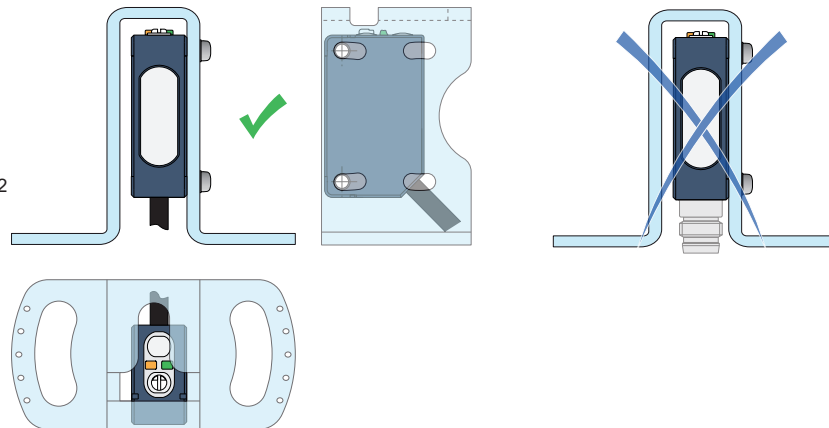
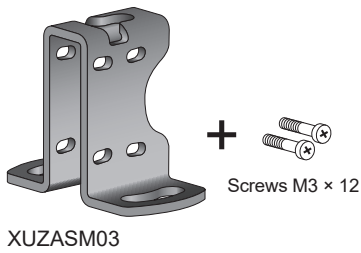
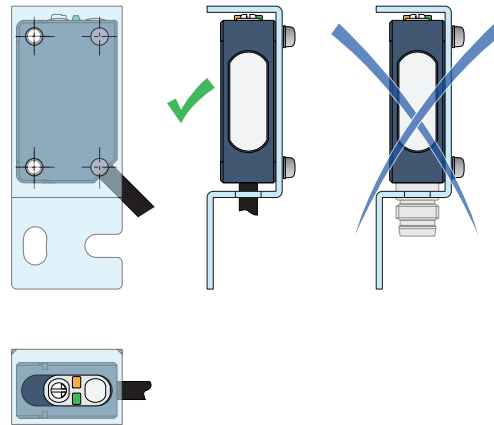
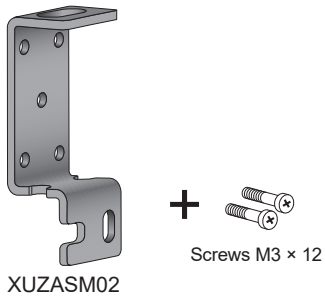
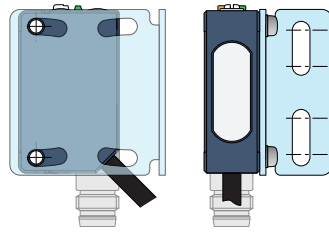
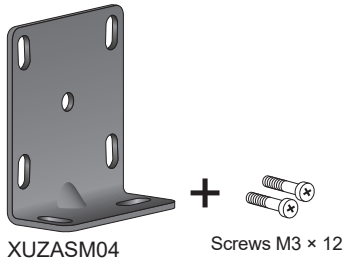
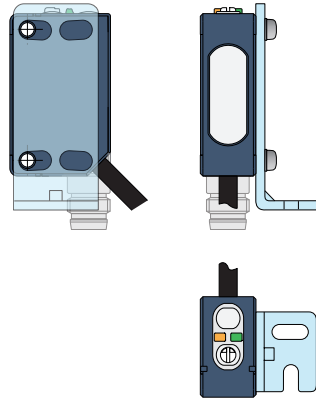
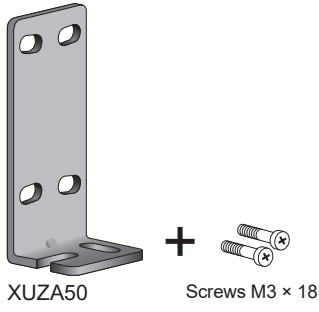

Accessories (continued)

Slits for thru-beam model (to order separately)

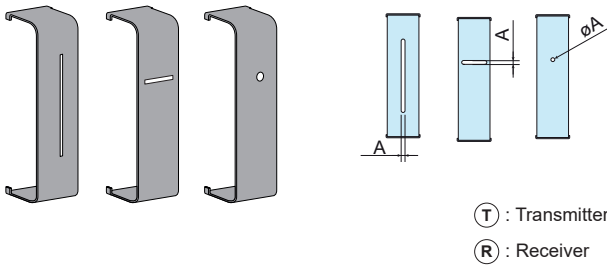

Slit and Sensing Range

A slit, which changes the beam size of through-beam sensors, can easily be attached to the sensing side of the through-beam transmitter and receiver.

Reference	Slit		Sensing Range				Minimum Detectable Object Width			
	Width: A		Used on (R)		Used on (R) + (T)		Used on (R)		Used on (R) + (T)	
	mm	in.	m	ft.	m	ft.	mm	in.	mm	in.
XUZDVM05	0,5	0.02	2,5	8.2	1	3.28	0,5	0.02	0,5	0.02
XUZDVM10	1	0.04	3,5	11.5	1,5	4.92	1	0.04	1	0.04
XUZDVM20	2	0.08	6	19.7	3,5	11.5	2	0.08	2	0.08
XUZDHM05	0,5	0.02	2	6.56	0,7	2.3	0,5	0.02	0,5	0.02
XUZDHM10	1	0.04	3	9.84	1,5	4.92	1	0.04	1	0.04
XUZDHM20	2	0.08	5,5	18	3	9.84	2	0.08	2	0.08
XUZDRM05	ø0,5	ø0.02	0,8	2.62	0,08	0.26	0,5	0.02	0,5	0.02
XUZDRM10	ø1	ø0.04	1,5	4.92	0,3	0.98	1	0.04	1	0.04
XUZDRM20	ø2	ø0.08	2,5	8.2	1,2	3.94	2	0.08	2	0.08

Note: Used on one side: Slit is attached to the receiver only.

Slit mounting

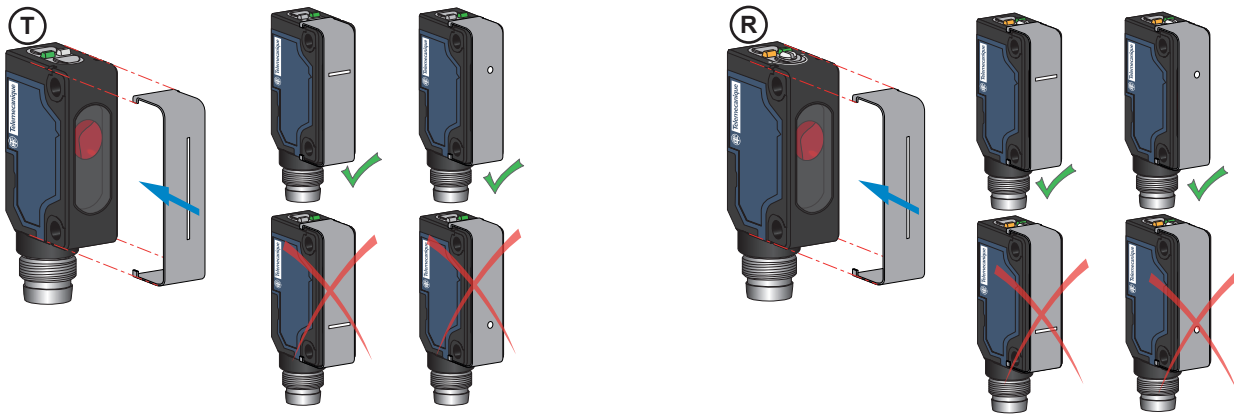

Pre-Wired connectors (examples)

PVC cable for general use
PUR cable for severe industrial environments

Cable length	M8, 4 pins		M8 - M12, 4 pins		Jumper length	M8 - M12, 4 pins	
	PVC	PUR	PVC	PUR		PUR	PUR
2 m / 6.56 ft.	XZCPV0941L2	XZCP0941L2	XZCPV1041L2	XZCP1041L2	1 m / 3.28 ft.	XZCR1509041J1	XZ CR1510041J1
5 m / 16.4 ft.	XZCPV0941L5	XZCP0941L5	XZCPV1041L5	XZCP1041L5	2 m / 6.56 ft.	XZCR1509041J2	XZCR1510041J2
10 m / 32.8 ft.	XZCPV0941L10	XZCP0941L10	XZCPV1041L10	XZCP1041L10			

Sensor Position Adjustment

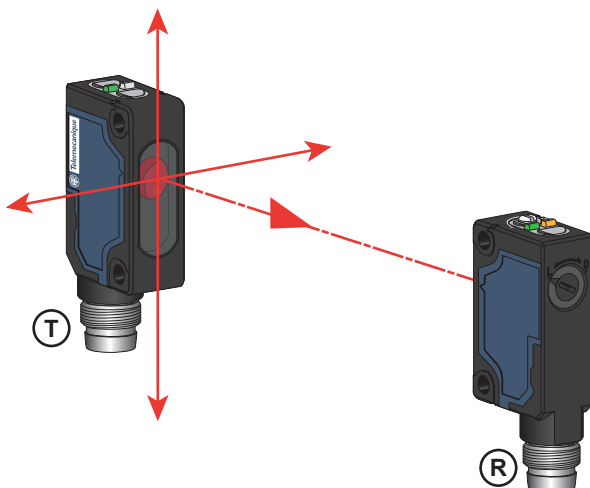

- Translate the transmitter or receiver, up/down and left/right. When the setting is optimal, the Output status LED (yellow) is lit (Light-on mode).
- Check sensor operation with the object and adjust the sensor, if necessary.

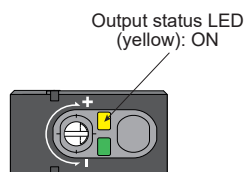

Output mode setting: Light-On or Dark-On (Light-On by default)

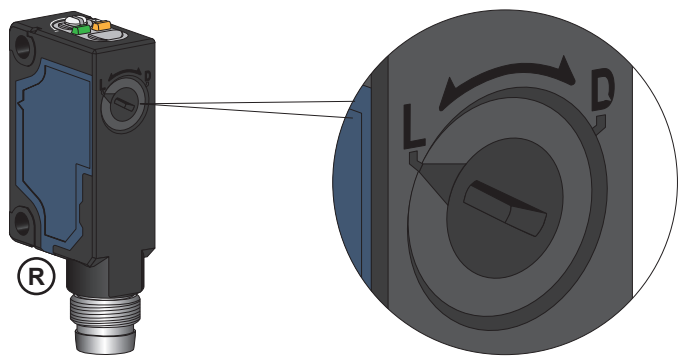

Light-On / Normally Closed	Dark-On / Normally Open
<p>The Output is ON</p>	<p>The Output is OFF</p>
<p>The Output is OFF</p>	<p>The Output is ON</p>

Sensor Sensitivity Adjustment

For accurate detection, follow the configuration below. (eg. Objects with holes or small size to obstruct the light beam).

	Light-on	Dark-on
	<p>1-Before settings, start with the receiver potentiometer at the maximum position (resulting to point A).</p>	<p>1-Before settings, start with the receiver potentiometer at the maximum position (resulting to point A).</p>
	<p>2-Connect the two sensors to the power supply (see page 1 for the wire connection & page 7 for the power voltage), the power ON led (green) switches on. Align the two sensors, as shown on the picture, until seeing the output led (yellow) switches on. Keep the two sensors within the sensing distance described in page 6.</p>	<p>2-Connect the two sensors to the power supply (see page 1 for the wire connection & page 7 for the power voltage), the power ON led (green) switches on. Align the two sensors, as shown on the picture, until seeing the output led (yellow) switches off. Keep the two sensors within the sensing distance described in page 6.</p>
	<p>3-Put the object to detect between the 2 sensors.</p> <ul style="list-style-type: none"> ● If the receiver output led (yellow) switches off, the object detection is set correctly. ● If the receiver doesn't detect the object (output led remained on), turn the potentiometer clockwise until the output led (yellow) switches off (resulting to point B). 	<p>3-Put the object to detect between the 2 sensors.</p> <ul style="list-style-type: none"> ● If the receiver output led (yellow) switches on, the object detection is set correctly. ● If the receiver doesn't detect the object (output led remained off), turn the potentiometer clockwise until the output led (yellow) switches on (resulting to point B).
	<p>4-The Sensor is set and ready to detect </p>	<p>4-The Sensor is set and ready to detect </p>

Detection curves

Lateral Displacement

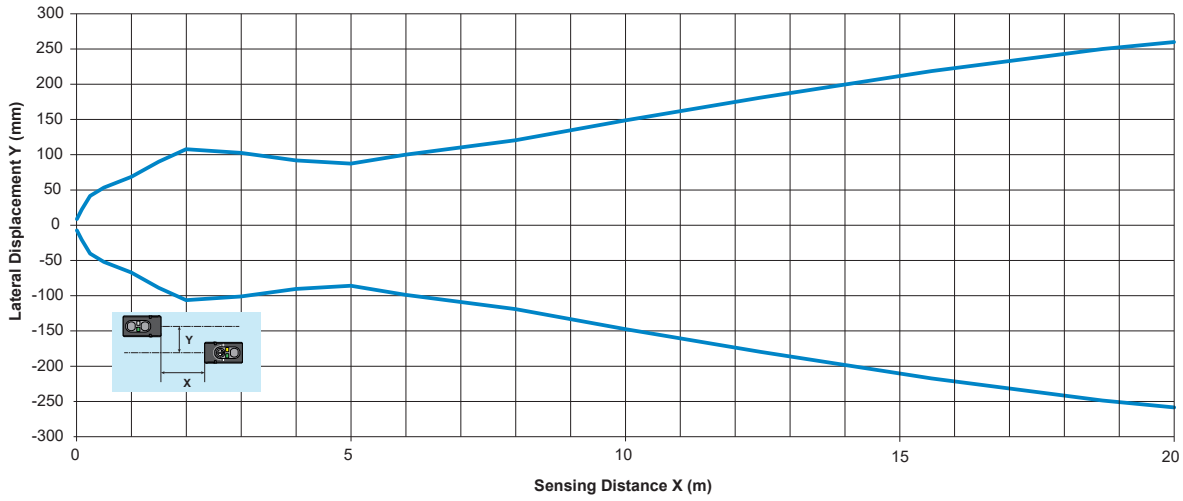

Light beam diameter

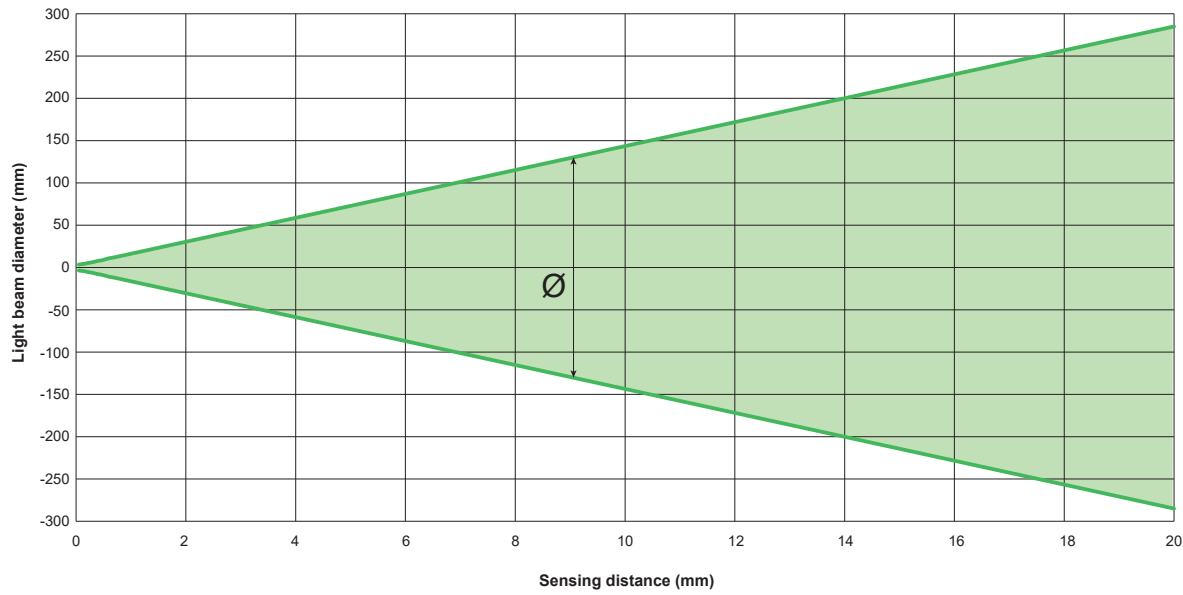

Excess gain

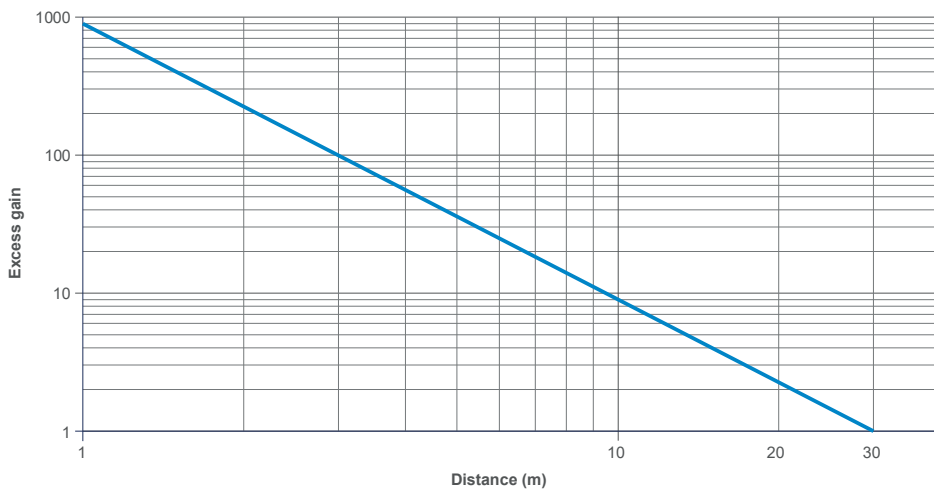

Characteristics

Certification	CE - UKCA - cULus
Sensing Range	24m = Excess gain 2 30m = Excess gain 1
Color of detection light beam	Red
Spot size of the light beam on the target	288 mm at 10 m 571 mm at 20 m
Hysteresis	2% < H < 20%
Sensing distance setting	Potentiometer 1 turn (~ 240 degrees) on the receiver
Light-On/Dark-On selection	Switch (~ 120 degrees) on the receiver
Output type	One open collector output, PNP or NPN
ON Voltage drop	< 2 V max.
Current consumption	Transmitter < 20 mA max. Receiver < 20 mA max.
Switching capacity	100 mA
First-up delay	100 ms max.
Response time	0,5 ms max.
Recovery time	0,5 ms max.
Switching frequency	1000 Hz
Electrostatic discharge immunity	4 kV (Contact), 8 kV (Air) conforming to IEC 61000-4-2
Electromagnetic field immunity	10 V/m conforming to IEC 61000-4-3
Fast transients immunity	Burst 5 kHz - 2 kV conforming to IEC 61000-4-4
Conducted disturbances immunity	10 V conforming to IEC 61000-4-6
Emissivity Radiated disturbances	Class A conforming to EN 55011 / CISPR 11
Power Voltage	Rated operational voltage: 12...24 Vdc Ripple p-p 10% maximum Operating range: 10...30 Vdc (including ripple) 
Product Protection	Power supply : Reverse polarity protection Output: Short circuit protection Reverse polarity protection
Light Immunity	Operating atmosphere; Sunlight 40 kLx max. Incandescent light 10 kLx max. (at the receiver surface)
Ambient Temperature	Operating : - 30...+55 °C (-22...+131 °F), Storage : - 40...+70 °C (-40...+158 °F)
Ambient Humidity	Operating : 35...95% RH, Storage : 35...95% RH
Degree of protection	IP65, IP67 conforming to EN/IEC 60529
Vibration resistance	Frequency range: 10 Hz to 500 Hz Acceleration: 9 g _n
Shock resistance	Peak acceleration: 100 g _n Duration of the pulse: 11 ms
Material	Housing: PBT, Lens: PMMA, Operation cover: PC, Adjustment potentiometer: PBT

