

See the workshop's help for the programming workshop and operation.
Those responsible for the application, implementation or use of this product must ensure that the necessary design considerations have been incorporated into each application, completely adhering to applicable laws, performance and safety requirements, regulations, codes and standards.
The customer is responsible for all consequences of the application.

Reportez-vous à l'aide de l'atelier de programmation pour le fonctionnement et l'utilisation de celui-ci.
Les responsables de l'application, de la mise en œuvre ou de l'utilisation de ce produit doivent s'assurer que les considérations nécessaires de conception ont été incorporées à chaque application, en parfaite adéquation aux lois, aux besoins de performance et de sécurité, à la réglementation, aux normes et standards. Le client est responsable des conséquences de son application.

Consulte la ayuda del taller para la operación y el uso de la programación.
Los responsables de la aplicación, implementación o uso de este producto deben asegurarse que las consideraciones de diseño necesarias hayan sido incorporadas en cada aplicación, completamente de acuerdo con las leyes, requerimientos de rendimiento y seguridad, regulaciones, códigos y modelos aplicables. El cliente es responsable de la consecuencia de su aplicación.

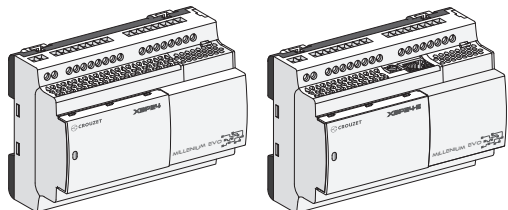

Millenium Evo XBP24
88975001 24 VDC/5 W

Millenium Evo XBP24-E
88975011 24 VDC/6.2 W

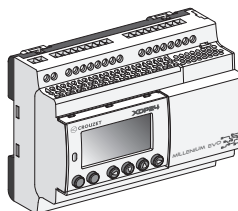

Millenium Evo XDP24
88975101 24 VDC/5.3 W

Millenium Evo XDP24-E
88975111 24 VDC/6.5 W

1 - Description / Description / Descripción

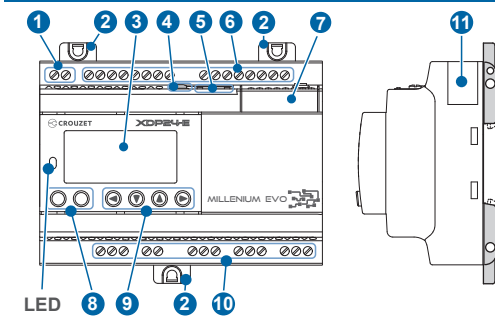

- EN**
- 1 Power supply terminals
- 2 Retractable mounting feet
- 3 LCD display
- 4 Functional earth
- 5 RJ45 connector
- 6 Input terminals
- 7 Location for interfaces
- 8 A and B pushbutton keys
- 9 Navigation keys
- 10 Output terminals
- 11 Expansion connector cap

- FR**
- 1 Borniers à vis d'alimentation
- 2 Pattes de fixation rétractables
- 3 Afficheur LCD
- 4 Terre fonctionnelle
- 5 Connecteur RJ45
- 6 Borniers à vis des entrées
- 7 Emplacement pour les interfaces
- 8 Boutons poussoir A et B
- 9 Touches de navigation
- 10 Borniers à vis des sorties
- 11 Capuchon du connecteur d'extension

- ES**
- 1 Terminales de tornillos de alimentación
- 2 Patas de fijaciones retractables
- 3 Pantalla LCD
- 4 Tierra funcional
- 5 Conector RJ45
- 6 Terminales de tornillos de las entradas
- 7 Emplazamiento para las interfaces
- 8 Entradas manuales A - B
- 9 Teclas de navegación
- 10 Terminales de tornillos de las salidas
- 11 Tapa del conector de extensión

Dimensions / Dimensions / Dimensiones

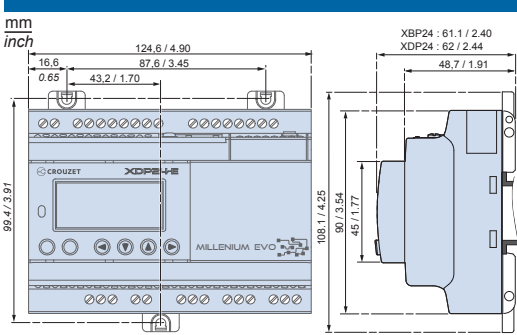

⚠ DANGER	⚠ DANGER	⚠ PELIGRO
<p>HAZARD OF ELECTRIC SHOCK, EXPLOSION OR ARC FLASH</p> <ul style="list-style-type: none"> - Turn power off before installing, removing, wiring or maintaining. <p>Failure to follow this instruction will result in death or serious injury.</p>	<p>RISQUE D'ELECTROCUTION, D'EXPLOSION OU D'ARC ELECTRIQUE</p> <ul style="list-style-type: none"> - Coupez l'alimentation avant d'installer, de câbler ou d'effectuer une opération de maintenance. <p>Le non-respect de cette instruction entrainera la mort ou des blessures graves.</p>	<p>RIESGO DE ELECTROCUCION, DE EXPLOSION O ARCO ELECTRICO</p> <ul style="list-style-type: none"> - Desconecte la alimentación antes de realizar los procesos de instalación, cableado, o mantenimiento. <p>Si no se respetan estas instrucciones, se producirán graves daños corporales o la muerte.</p>
⚠ WARNING	⚠ AVERTISSEMENT	⚠ ADVERTENCIA
<p>EXPLOSION HAZARD</p> <ul style="list-style-type: none"> - Confirm that the product power supply voltage and its tolerances are compatible with those of the network. - Do not disconnect equipment unless power has been switched off or the area is known to be non-hazardous. <p>UNINTENDED EQUIPMENT OPERATION</p> <ul style="list-style-type: none"> - This product is not intended for use in safety critical machine functions. Where personnel and or equipment hazard exists, use appropriate hard-wired safety interlocks. - Do not disassemble, repair or modify the controllers. - This controller is designed for use within an enclosure according to specifications described in these instructions in the paragraph on installation conditions. - Install the controllers in the operating environment conditions described below. <p>Failure to follow these instructions can result in death, serious injury or equipment damage.</p>	<p>RISQUE D'EXPLOSION</p> <ul style="list-style-type: none"> - Assurez-vous que la tension d'alimentation du produit, avec ses tolérances, est compatible avec celles du réseau. - Assurez-vous que l'alimentation est coupée ou que la zone ne présente aucun danger avant de connecter l'équipement. <p>OPERATION D'EQUIPEMENT NON INTENTIONNELLE</p> <ul style="list-style-type: none"> - Ce produit ne doit pas être utilisé dans des fonctions critiques de machine de sûreté. Là où il existe des risques pour le personnel et/ou le matériel, utilisez les contacts de sécurité câblés appropriés. - Veuillez ne pas démonter, réparer, ni modifier le contrôleur. - Ce contrôleur logique doit être utilisé dans une enceinte fermée, selon les spécifications décrites dans cette notice, au paragraphe Conditions d'installation. - Installez les contrôleurs dans un environnement de fonctionnement normal, comme indiqué. <p>Le non-respect de ces instructions peut entraîner la mort, des lésions corporelles graves ou des dommages matériels.</p>	<p>RIESGO DE EXPLOSION</p> <ul style="list-style-type: none"> - Asegúrese de que la tensión de alimentación del producto y sus tolerancias son compatibles con las de la red eléctrica. - No conecte el equipo a menos que se haya eliminado la alimentación o que la zona no sea peligrosa. <p>OPERACION DEL EQUIPO INVOLUNTARIA</p> <ul style="list-style-type: none"> - Este producto no está diseñado para un uso en funciones críticas de una maquina de seguridad. Donde existan riesgos para el personal o el equipamiento, use cierres de seguridad cableados adaptados. - No desmonte, repare ni modifique los productos. - Este producto está diseñado para un uso en un recinto cerrado, según las especificaciones que se describen en estas instrucciones, en el párrafo de Condiciones de Instalación. - Instale los productos en las condiciones de entorno de funcionamiento descritas. <p>Si no se respetan estas precauciones pueden producirse graves lesiones, daños materiales o incluso la muerte.</p>

2 - Installation / installation / instalación

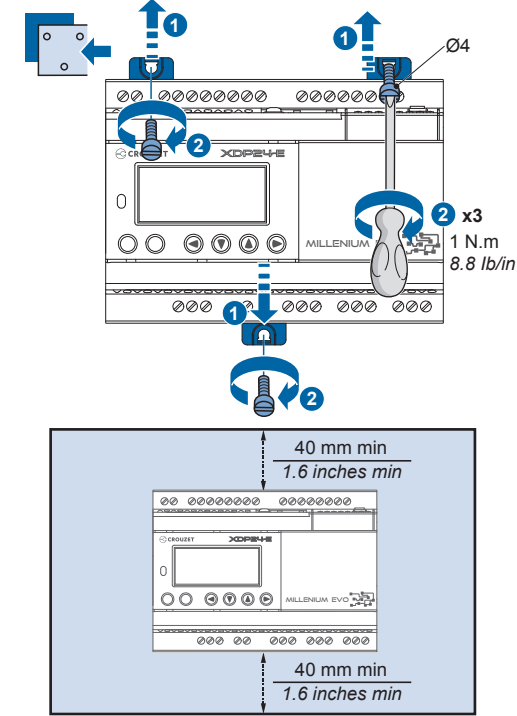
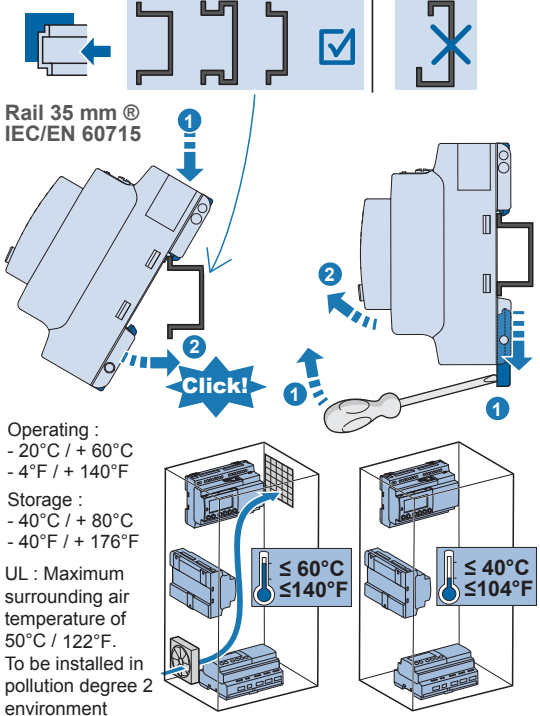

3 - Connection / Raccordement / Conexión

mm inch	0.2...2.5	0.2...0.75	0.2...2.5	0.2...0.75
mm²	0.2...2.5	0.2...0.75	0.2...2.5	0.2...0.75
AWG	24...14	24...18	24...14	24...18

UL : Cu, 75°C min

4 - Inputs / Entrées / Entradas

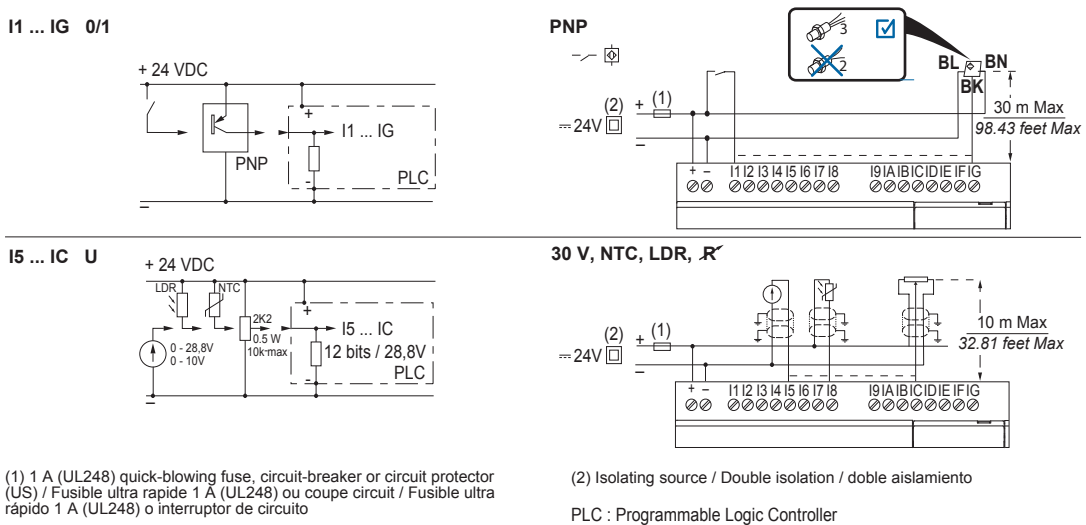

4 - Inputs / Entrées / Entradas

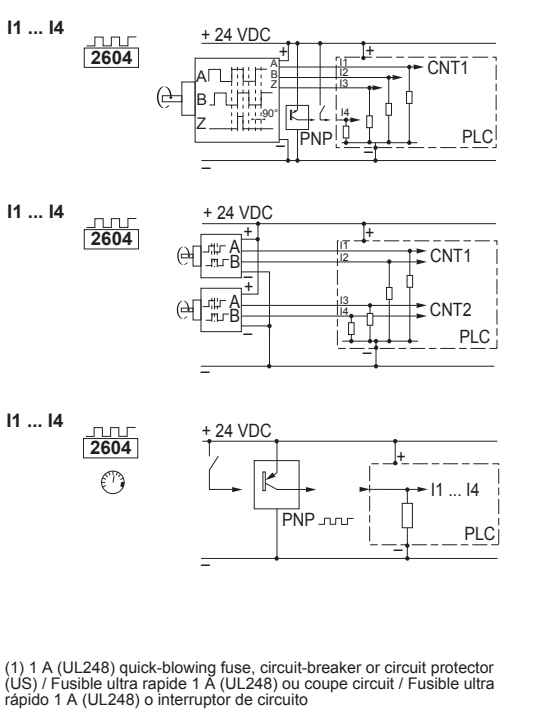

4 - Inputs / Entrées / Entradas

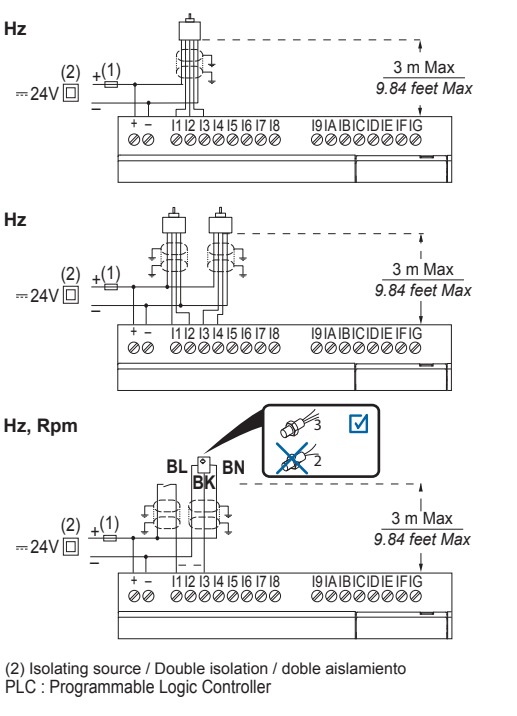

5 - Outputs / Sorties / Salidas

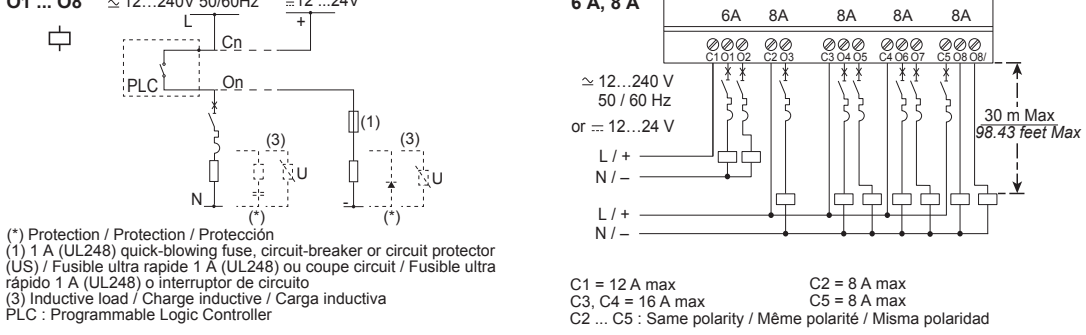

7 - Operation / Fonctionnement / Funcionamiento

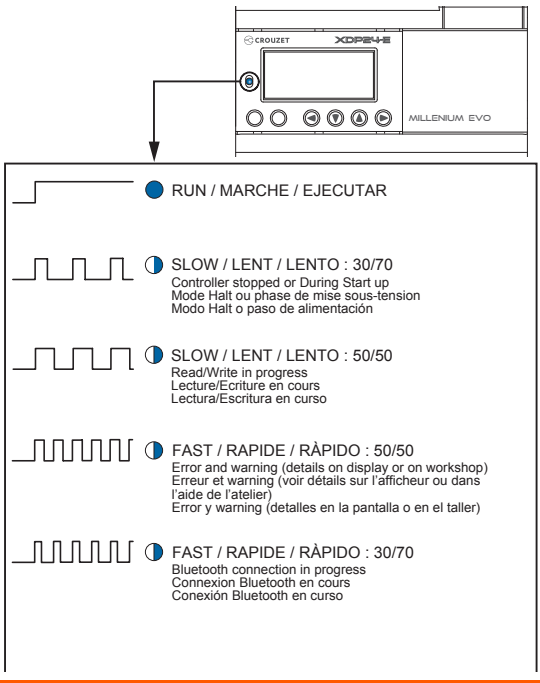

8 - Accessories / Accessoires / Accesorios

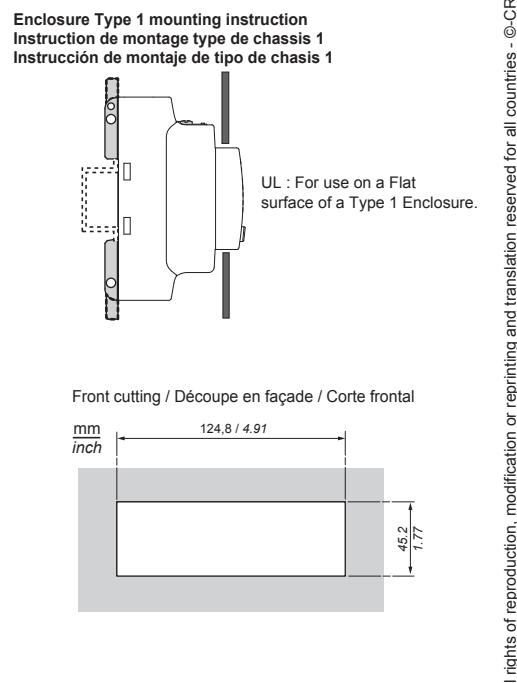

6 - Interfaces / Interfaces / Interfaces

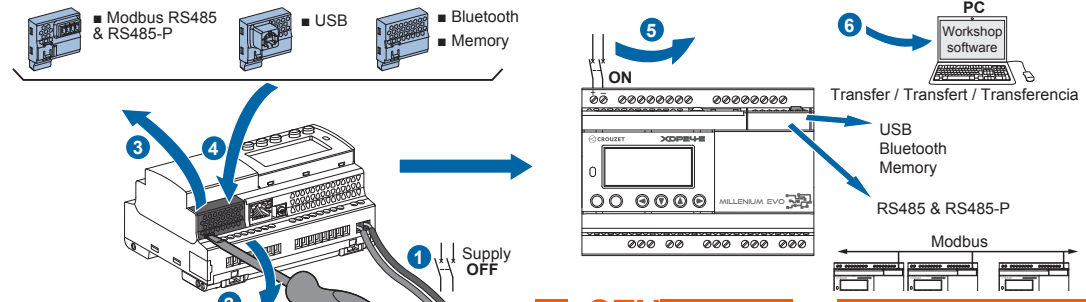

Name Nom Nombre	R/W	Address Adresse Dirección
XWIN	R/W	0001
XWIN	R/W	0002
:	:	:
XWIN	R/W	0015
XWIN	R/W	0016
XBIN (Word)	R/W	0025
XWOUT	R	0026
XWOUT	R	0027
:	:	:
XWOUT	R	0040
XWOUT	R	0041
XBOUT (Word)	R	0050

Modbus functions supported
Fonctions Modbus supportées
Funciones Modbus soportados

Code (Hexa)	Function	Data Type
0x01 (R)	Read Coils	N x 8 bits
0x03 (R)	Read multiple registers (R)	N x 16 bits (Word)
0x05 (W)	Write single Coil (OFF)	2 x 16 bits 0x0000: request the coil to be OFF
	Write single Coil (ON)	2 x 16 bits 0xFF00: request the coil to be ON
0x06 (W)	Write single register (W)	16 bits (Word)
0x0F (W)	Write multiple coils (W)	N x 8 bits (Word)
0x10 (R/W)	Write multiple registers(W)	N x 16 bits (Word)
0x2B (R)	Read device identification (R)	ASCII string

LSB STATE ETAT LSB ESTADO LSB	R	0051	0x0000 : Stop - Stop - Stop	0x0001 : Run - Run - Ejecutar 0x0002 : Debugging - Debugging - Debugging 0x0040 : Setting front - Paramétrage en face avant - Ajuste frontal
MSB STATE ETAT MSB ESTADO MSB	R	0052	0x0000	
LSB STATUS STATUT LSB ESTADO LSB	R	0053	See code warning / error - Voir code warning / erreur - Ver código de advertencia / error	
MSB STATUS STATUT MSB ESTADO MSB	R	0054	See code warning / error - Voir code warning / erreur - Ver código de advertencia / error	
CLOCK HORLOGE RELOJ	R/W	0055	Second - Seconde - Segundo	
	R/W	0056	Minute - Minute - Minuto	
	R/W	0057	Hour - Heure - Hora	
	R/W	0058	Weekday - Jour de la semaine - Día de la semana	0x0000 : Monday - Lundi - Lunes 0x0006 : Sunday - Dimanche - Domingo
	R/W	0059	Day of the month - Jour du mois - Día del mes	
	R/W	0060	Month - Mois - Mes	
	R/W	0061	Year - Année - Año	
SUMMER/WINTER ETE/HIVER VERANO/INVIERNO	R/W	0063	Change - Changement - Cambio	0x0000 : invalid - non validé - no validado 0x0001 : Europe - Europe - Europa 0x0002 : USA - USA - Estados Unidos de América 0x0003 : manual - manuel - manual
	R/W	0064	SUMMER month - Mois ETE - Mes de VERANO	0x0001 : January - Janvier - Enero 0x000C : December - Décembre - Diciembre
	R/W	0065	Date SUMMER - Date ETE - Fecha de VERANO	0x0001 : 1 st Sunday - 1 ^{er} dimanche - 1er domingo 0x0005 : 5 th Sunday - 5 ^{eme} dimanche - 5to domingo
	R/W	0066	WINTER Month - Mois HIVER - Mes de INVIERNO	0x0001 : January - Janvier - Enero 0x000C : December - Décembre - Diciembre
	R/W	0067	WINTER Date - Date HIVER - Fecha de INVIERNO	0x0001 : 1 st Sunday - 1 ^{er} dimanche - 1er domingo 0x0005 : 5 th Sunday - 5 ^{eme} dimanche - 5to domingo
DRIFT DERIVE DERIVA	R/W	0068	Drift - Dérive - Deriva	0xFFC5 : -59 0x003B : +59
RUN/STOP	W	0069	0x0000 : Stop - Stop - Parar	0x0001 : Run - Run - Ejecutar
XBIN (bit) code: 0x01, 0x05	R/W	1000 1007		
XBOUT (bit) code: 0x01	R	1016 1023		

Routing the wires:

Routing the wires, running along metal structures, in trunking, through grommets, etc... must be done according to type.

Routage des torons:

Le routage des torons, plaqués sur les structures métalliques, bâtis d'armoire, goulottes, etc... doit se faire par catégories.

El transporte de las líneas:

El transporte de las líneas, emplazadas sobre las estructuras metálicas, fondo de armario, cana letas, etc... debe hacerse por familias.

Linking cable support:

All the cable supports must be connected together, to the equipment and, if possible, to the structure of the building by metal braids.

Maillage des supports de câbles:

Tous les supports de câbles doivent être reliés entre eux, aux équipements et si possible aux structures du bâtiment par des tresses métalliques.

Entredados de los soportes de cables:

Todos los soportes de cable deben estar unidos entre ellos, a los equipos y si posible a las estructuras del edificio mediante trenzas metálicas.

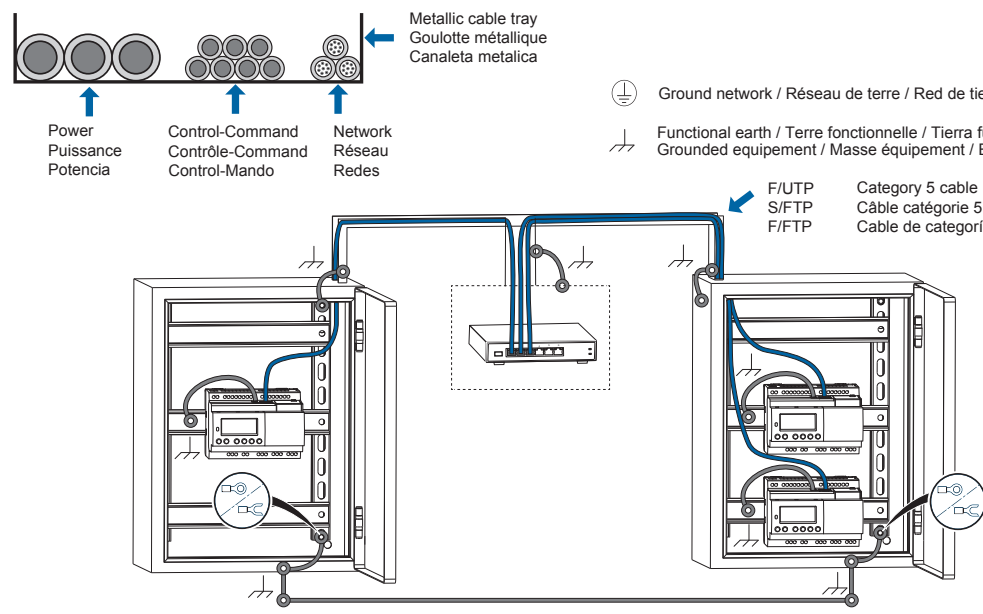

If there is risk of non ground equipotentiality between two remote devices (usually this is the case of equipment in different buildings), the network (bus) must be isolated with radio links, optical links or networks insulators.

S'il y a risque de non équipotentialité des terres entre deux équipements distants (en général c'est le cas des équipements dans des bâtiments différents), il faut isoler le réseau (bus) soit à l'aide de liaisons radios ou optiques ou bien avec des isolateurs de réseaux.

Si hay riesgo de no equipotencialidad de tierra entre dos equipos remotos (generalmente es el caso de dos equipos ubicados en dos edificios distintos) se debe aislar la red (bus) vía una conexión radial u óptica o bien utilizando aisladores de redes.

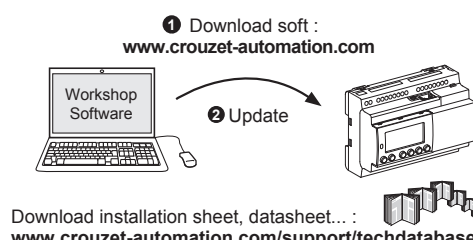

Download installation sheet, datasheet... : www.crouzet-automation.com/support/techdatabase

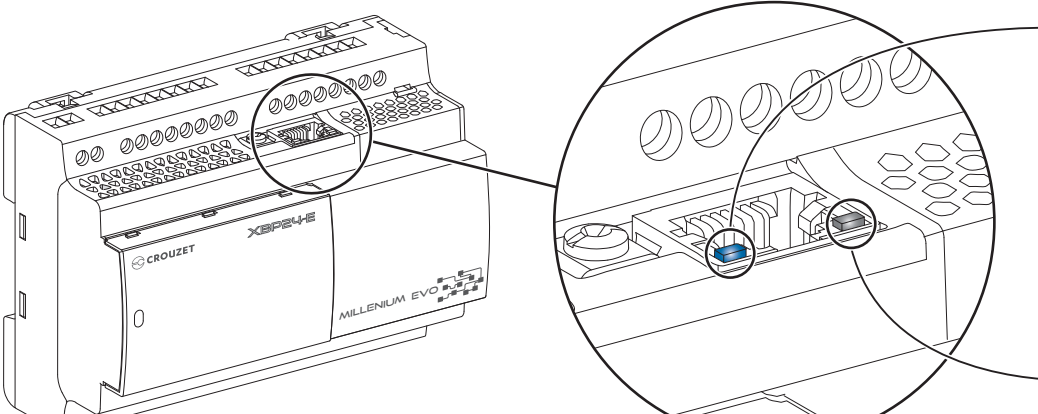

LK/ACT 10/100	<ul style="list-style-type: none"> ○ OFF / ÉTEINT / APAGADO : No Ethernet connection Pas de connexion Ethernet Sin conexión Ethernet ● GREEN LIGHT / ALLUMÉ VERT / ENCENDIDO VERDE : Ethernet connection 100 Mbits/s Connexion Ethernet 100 Mbits/s Conexión Ethernet 100 Mbits/s ⦿ GREEN BLINKING / CLIGNOTANT VERT/ VERDE PARPADEANTE : Data exchange 100 Mbit/s Echange de données à 100 Mbits/s Intercambio de datos a 100 Mbits/s ● YELLOW LIGHT / ALLUMÉ JAUNE / ENCENDIDO AMARILLO : Ethernet connection 10 Mbits/s Connexion Ethernet 10 Mbits/s Conexión Ethernet 10 Mbits/s ⦿ YELLOW BLINKING / CLIGNOTANT JAUNE / AMARILLO PARPADEANTE : Data exchange 10 Mbit/s Echange de données à 10 Mbits/s Intercambio de datos a 10 Mbits/s
STS	<ul style="list-style-type: none"> ● GREEN LIGHT / ALLUMÉ VERT / ENCENDIDO VERDE : Ethernet Module powered up and ready for communication Module Ethernet alimentada et prêt pour la communication Módulo Ethernet alimentada y preparada para la comunicación ⦿ GREEN BLINKING / CLIGNOTANT VERT/ VERDE PARPADEANTE : Ethernet initializing Connexion Ethernet en cours d'initialisation Comunicación Ethernet en curso de inicialización ⦿ 4 GREEN BLINKS / 4 FLASHS VERT / 4 VERDE PARPADEOS : Getting the IP address Obtention de l'adresse IP en cours Obtención de la dirección IP en curso ● RED LIGHT / ALLUMÉ ROUGE / ENCENDIDO ROJO : Internal fault or duplicate IP address detected on the network Défaut interne ou doublon de l'adresse IP détecté sur le réseau Fallo interno o repetición de la dirección IP detectado en la red ⦿ RED BLINKING / CLIGNOTANT ROUGE / ROJO PARPADEANTE : Product supplied but not set Produit alimenté mais non paramétré Producto alimentado pero sin parametros

Third-party softwares components :

STMicroelectronics HAL drivers :

Copyright (c) 2015 STMicroelectronics

Redistribution and use in source and binary forms, with or without modification, are permitted provided that the following conditions are met:

1. Redistributions of source code must retain the above copyright notice, this list of conditions and the following disclaimer.
2. Redistributions in binary form must reproduce the above copyright notice, this list of conditions and the following disclaimer in the documentation and/or other materials provided with the distribution.
3. Neither the name of STMicroelectronics nor the names of its contributors may be used to endorse or promote products derived from this software without specific prior written permission.

THIS SOFTWARE IS PROVIDED BY THE COPYRIGHT HOLDERS AND CONTRIBUTORS "AS IS" AND ANY EXPRESS OR IMPLIED WARRANTIES, INCLUDING, BUT NOT LIMITED TO, THE IMPLIED WARRANTIES OF MERCHANTABILITY AND FITNESS FOR A PARTICULAR PURPOSE ARE DISCLAIMED. IN NO EVENT SHALL THE COPYRIGHT HOLDER OR CONTRIBUTORS BE LIABLE FOR ANY DIRECT, INDIRECT, INCIDENTAL, SPECIAL, EXEMPLARY, OR CONSEQUENTIAL DAMAGES (INCLUDING, BUT NOT LIMITED TO, PROCUREMENT OF SUBSTITUTE GOODS OR SERVICES; LOSS OF USE,

DATA, OR PROFITS; OR BUSINESS INTERRUPTION) HOWEVER CAUSED AND ON ANY THEORY OF LIABILITY, WHETHER IN CONTRACT, STRICT LIABILITY, OR TORT (INCLUDING NEGLIGENCE OR OTHERWISE) ARISING IN ANY WAY OUT OF THE USE OF THIS SOFTWARE, EVEN IF ADVISED OF THE POSSIBILITY OF SUCH DAMAGE.

lwIP :

Copyright (c) 2001-2004 Swedish Institute of Computer Science. All rights reserved.

Redistribution and use in source and binary forms, with or without modification, are permitted provided that the following conditions are met:

1. Redistributions of source code must retain the above copyright notice, this list of conditions and the following disclaimer.
2. Redistributions in binary form must reproduce the above copyright notice, this list of conditions and the following disclaimer in the documentation and/or other materials provided with the distribution.
3. The name of the author may not be used to endorse or promote products derived from this software without specific prior written permission.

THIS SOFTWARE IS PROVIDED BY THE COPYRIGHT HOLDERS AND CONTRIBUTORS "AS IS" AND ANY EXPRESS OR IMPLIED WARRANTIES, INCLUDING, BUT NOT LIMITED TO, THE IMPLIED WARRANTIES OF MERCHANTABILITY AND FITNESS FOR A PARTICULAR PURPOSE ARE DISCLAIMED. IN NO EVENT SHALL THE COPYRIGHT HOLDER OR CONTRIBUTORS BE LIABLE FOR ANY DIRECT, INDIRECT, INCIDENTAL, SPECIAL, EXEMPLARY, OR CONSEQUENTIAL DAMAGES (INCLUDING, BUT NOT LIMITED TO, PROCUREMENT OF SUBSTITUTE GOODS OR SERVICES; LOSS OF USE,

DATA, OR PROFITS; OR BUSINESS INTERRUPTION) HOWEVER CAUSED AND ON ANY THEORY OF LIABILITY, WHETHER IN CONTRACT, STRICT LIABILITY, OR TORT (INCLUDING NEGLIGENCE OR OTHERWISE) ARISING IN ANY WAY OUT OF THE USE OF THIS SOFTWARE, EVEN IF ADVISED OF THE POSSIBILITY OF SUCH DAMAGE.

Contact information / Information de contact / Información del contacto



www.crouzet-automation.com/contact
FR - 26000 Valence