

Set up for metallic tear-tape

Step 1

Set GAIN to MIDPOINT (50)

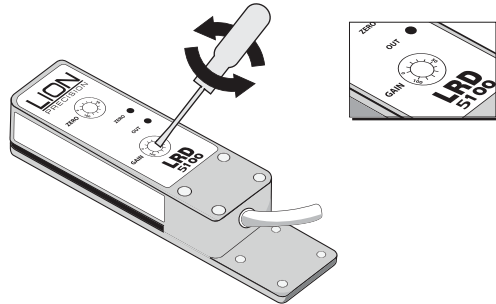

Step 2

With no material, or only web material (no tear-tape) placed in the gap, adjust ZERO until the OUTPUT light turns off then turn the zero control clockwise 1 tick.

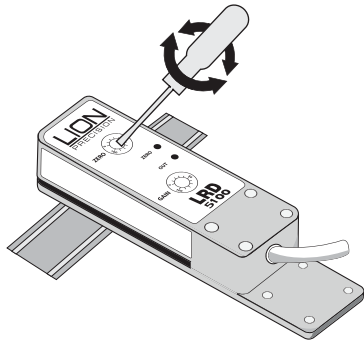

Step 3

Verify proper operation with tear-tape present

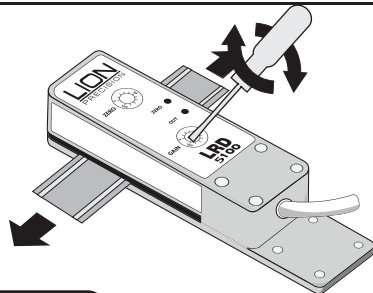

Output Waveform

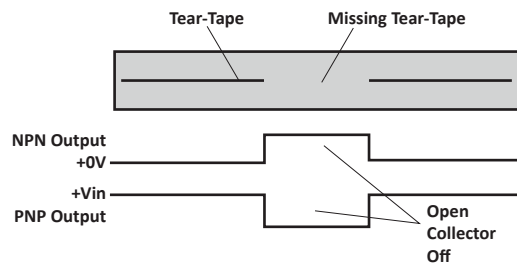

LION PRECISION

*Be confident when you do
business with Lion Precision.*

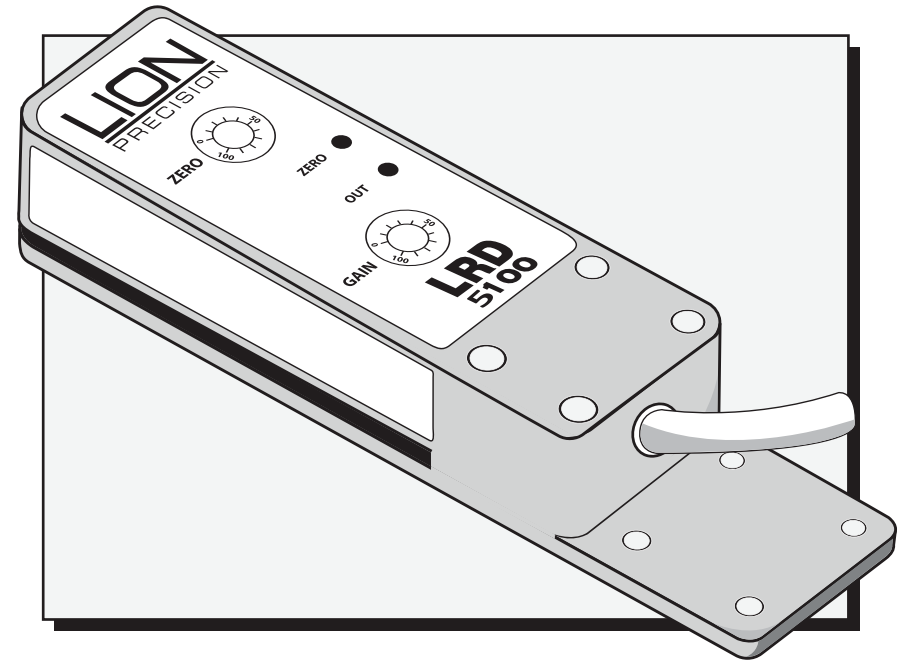

USER'S GUIDE

for the

LRD 5100 & LRD 5100C

**Label Sensors
with Single-Turn Adjustments**

Warnings

Sensor body is connected to Ground. Sensors must not be attached to voltages in excess of 30VRMS or 60VDC. Use of the equipment in any other manner may impair the safety and EMI protections of the equipment. All power must be off when installing the sensor.

Specifications

Power Supply	Voltage	11-24 V $\overline{=}$ (reverse polarity protected)
	Current	50mA
Response time	on or off	20 μ s Max
	Switching Frequency	10kHz Max
Output	Output Current (sinking or sourcing)	150mA Max (overload protected)
	Switching Output	PNP (sourcing) or NPN (sinking) w/ Dark or light switching
Temperature	Operating Range	40° F -140° F (4° C - 60° C)
	Supply	Inverse polarity protection
Protections	Switching Output	Short circuit and overload protection

Dimensions

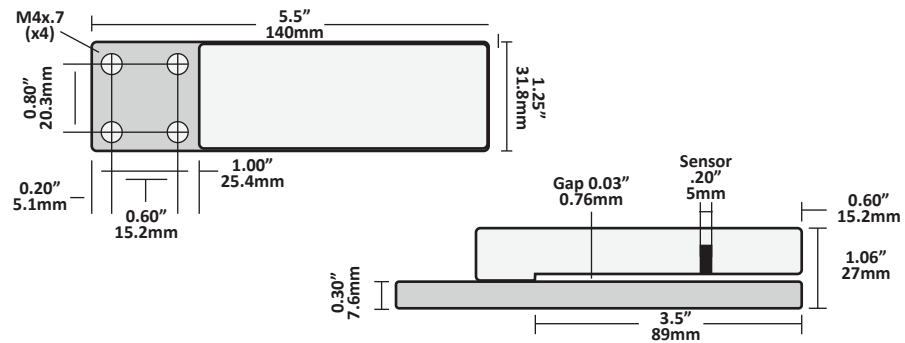

LRD 5100 Wiring

Wire Color	Connection	Notes
Red	Vin (11-24 V $\overline{=}$)	50mA max
Black	Ground	Connected to sensor body
Green	NPN Output	150mA max
Blue	PNP Output	150mA max
Brown	No Connection	

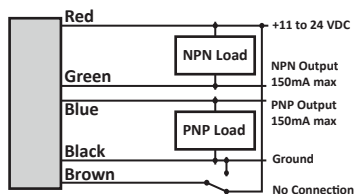

LRD 5100C Wiring

Wire Color	Connection	Notes
1 (Brown)	Vin (11-24V $\overline{=}$)	50mA max
2 (White)	NPN Output	150mA max
3 (Blue)	Ground	Connected to sensor body
4 (Black)	PNP Output	150mA max
5 (Gray)	No Connection	

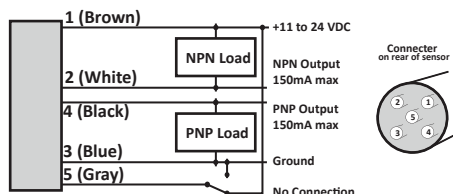

Set up for non-metallic tear-tape

The adjustments on the LRD 5100 are marked maximum as '100' and the minimum is marked as '0'. Turning the adjustments past the maximum and or minimum will result in damage to the sensor. Adjustments when first installed on a machine are seen below.

Step 1

Set GAIN to MIDPOINT (50)
Remove all materials from sensor

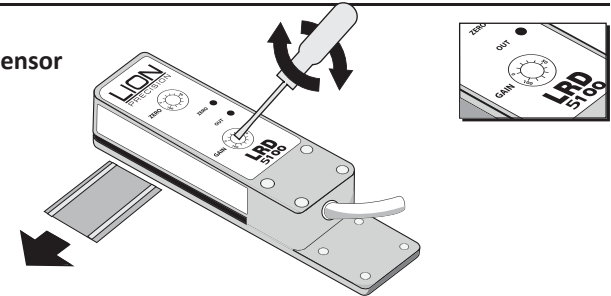

Step 2

Set ZERO
With the web material placed in the gap of the sensor and the tear-tape properly lined up on the "STRIP" marker, set the ZERO control to MINIMUM (0) and turn clockwise until the ZERO light just turns on.

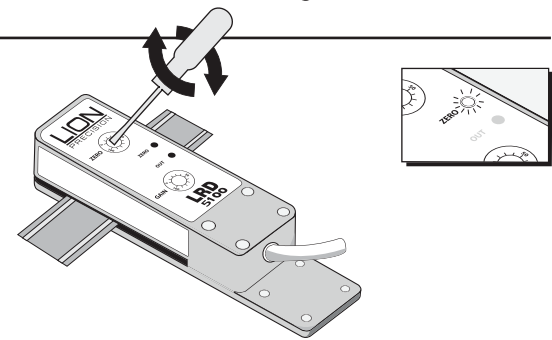

Step 3

Remove section of tear-tape

Pass the "tear-tape missing" and "tear-tape present" sections back and forth under the sensor. If the OUTPUT light flashes at the transitions between missing and present tear-tape, setup is complete.

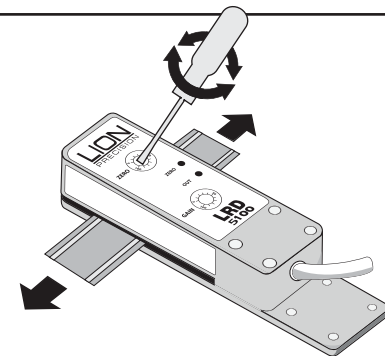

Step 4

If the OUTPUT light does not flash at the transitions, turn the GAIN control clockwise until it does.

