

Contact-Type Digital Displacement Sensor

## HG-S Series

# User's Manual

---

(MEMO)

Thank you for purchasing an contact-type digital displacement sensor **HG-S** series.  
Before using this product, read and understand this User's Manual. Use the product correctly and in the optimum manner.  
Keep this manual in a safe location for reference whenever necessary.

**Please note**

- 1) Unauthorized reproduction of part or all of this manual is prohibited.
- 2) The contents of this manual are subject to change without notice.
- 3) This manual has undergone strict quality control procedures; however, in the event that you discover any problems or points of concern, please contact your local dealer.

# Contents

Chapter 1 INTRODUCTION	1-1
1-1 Safety Cautions	1-2
1-2 Safety Information	1-2
Chapter 2 BEFORE USING THIS PRODUCT	2-1
2-1 Contents of Package	2-2
2-2 System Configuration	2-5
2-3 Description of Parts	2-6
2-3-1 Controller	2-6
2-3-2 Sensor Head (Regular Type)	2-8
2-3-3 Sensor Head (Air-Driven Type)	2-8
2-3-4 Sensor Head Connection Cable	2-9
Chapter 3 INSTALLATION AND CONNECTIONS	3-1
3-1 Mounting the Controller	3-2
3-1-1 Mounting on a DIN Rail	3-2
3-1-2 Removing from a DIN Rail	3-2
3-2 Attaching the Sensor Head	3-3
3-3 Wiring the Controller Connector on the Sensor Head Connection Cable	3-5
3-3-1 Disassembly Procedure	3-5
3-3-2 Wiring Procedure	3-5
3-4 Connecting the Controller and Sensor Head	3-7
3-4-1 Attaching the Sensor Head and Sensor Head Connection Cable	3-7
3-4-2 Removing the Sensor Head and Sensor Head Connection Cable	3-8
3-4-3 Connecting the Air Tube (Air-Driven Type Only)	3-9
3-4-4 Disconnecting the Air Tube (Air-Driven Type Only)	3-9
3-4-5 Air Circuit (Recommended) (Air-Driven Type Only)	3-10
3-4-6 Attaching the Controller and Sensor Head Connection Cable	3-11
3-4-7 Removing the Controller and Sensor Head Connection Cable	3-11
3-5 Connecting Controllers	3-12
3-5-1 Connection Method	3-13
3-5-2 Removal Method	3-15
3-6 Connection Diagrams and I/O Circuit Diagrams	3-16
3-6-1 Connection Diagrams	3-16
3-6-2 I/O Circuit Diagrams	3-18
Chapter 4 BASIC OPERATION	4-1
4-1 Explanation of Basic Operation	4-2
4-1-1 From Power ON to Mode Selection	4-2
4-1-2 Operation Keys and Display	4-3
4-2 Explanation of Modes	4-5
4-2-1 Display Switching Mode	4-5
4-2-2 Presets	4-8
4-2-3 Teaching Mode	4-11
4-2-4 Bank Mode	4-20
4-2-5 Key Lock	4-24

Chapter 5 FUNCTION SETTINGS .....	5-1
5-1 Overview of Setting Menu .....	5-4
5-1-1 Menu Structure .....	5-4
5-1-2 Data Flow .....	5-6
5-1-3 Setting Items and Default Values .....	5-7
5-2 Basic Settings (BASIC) .....	5-10
5-2-1 HIGH Set Value (HISET) .....	5-11
5-2-2 LOW Set Value (LOSET) .....	5-12
5-2-3 Hysteresis (HYSTER) .....	5-13
5-2-4 Teaching Types (TEACH) .....	5-15
5-2-5 Tolerance <±> (TOL (±)) .....	5-17
5-2-6 Preset Value (PRVAL) .....	5-18
5-2-7 Preset Data Selection (PROBJ) .....	5-19
5-2-8 Preset Save (PRSAVE) .....	5-20
5-2-9 Measurement Direction (DIRECT) .....	5-21
5-2-10 Lever Ratio (LEVER) .....	5-23
5-2-11 Response Time (SPEED) .....	5-24
5-2-12 Output Operation (OUTPUT) .....	5-26
5-3 Advanced Settings (ADVANC) .....	5-27
5-3-1 Hold Setting (HOLD) .....	5-28
5-3-2 Input All (ALL IN) (Master Unit Only) .....	5-47
5-3-3 External Input (EXTIN) .....	5-49
5-3-4 External Output (EXTOUT) .....	5-51
5-3-5 Number of Digits Displayed (DIGIT) .....	5-54
5-3-6 Analog Scaling (ANALOG) .....	5-55
5-3-7 Scaling Upper Limit Value / Scaling Lower Limit Value (ANAH1 / ANALO) .....	5-57
5-3-8 Eco Mode (ECO) .....	5-60
5-3-9 Alarm Setting (ALARM) .....	5-61
5-4 Calculation Settings (CALC) (Master Unit Only) .....	5-70
5-4-1 Calculation Mode (MODE) .....	5-71
5-4-2 Calculation Application Selection (APPLI) .....	5-72
5-5 Copy Settings (COPY) .....	5-79
5-5-1 Copy select individual (CPYSEL) (Master Unit Only) .....	5-81
5-5-2 Copy Select All (CHKALL) (Master Unit Only) .....	5-83
5-5-3 Copy Execution (CPYEXE) (Master Unit Only) .....	5-84
5-5-4 Copy Lock (LOCK) (Slave Units Only) .....	5-85
5-6 Bank Settings (BANK) .....	5-86
5-6-1 Bank Save Setting (BNKDAT) .....	5-86
5-7 Calibration Settings (CALIB) .....	5-88
5-7-1 Calibration Selection (CALSEL) .....	5-88
5-8 Initialization (RESET) .....	5-92
5-9 Maintenance (MAINTN) .....	5-94

Chapter 6 SPECIFICATIONS .....	6-1
6-1 Specifications .....	6-2
6-2 Dimensions .....	6-7
Chapter 7 Appendix .....	7-1
7-1 Maintenance and Inspection .....	7-2
7-1-1 Maintenance Cautions .....	7-2
7-1-2 Main Inspection Items .....	7-2
7-2 Replacing the Probe .....	7-3
7-3 Replacing the Rubber Bellows (Regular Type Only) .....	7-4
7-4 Replacing the Seal Cap (Air-Driven Type Only) .....	7-6
7-4-1 How to Remove the Seal Cap .....	7-6
7-4-2 How to Mount the Seal Cap .....	7-6
7-5 Error Messages .....	7-7
7-6 Troubleshooting .....	7-8

# Chapter 1 INTRODUCTION

---

1-1 Safety Cautions .....	1-2
1-2 Safety Information .....	1-2

# INTRODUCTION

## 1-1 Safety Cautions Always observe

This section explains important rules that must be observed to prevent human injury and property damage.

- The hazards that may occur if the product is used incorrectly are described and classified by level of harm.

 **WARNING** Risk of death or serious injury.

 **CAUTION** Risk of minor injury or property damage.

- The following symbols are used to indicate safety information that must be observed.

 Indicates an action that is prohibited.

 Indicates an action that must be taken.

 Indicates a matter that requires caution.

<Reference> Indicates supplemental information.

## 1-2 Safety Information

### **WARNING**

- Never use this product as a sensing device for personnel protection.
- When using sensing devices for personnel protection, use products that meet the laws and standards for personnel protection that apply in each region or country, such as OSHA, ANSI and IEC.

### **CAUTION**

- For the controller DC power supply, only use a power supply that is isolated by means of an isolation transformer or otherwise.
- Risk of short-circuiting and damage to the controller or power supply if a transformer such as an auto transformer is used. Risk of short-circuiting and damage to the controller or power supply if incorrectly mounted or connected.
- The controller **HG-SC** series is designed to be used with the special sensor head **HG-S** series. If used with other than the special sensor head option, the specifications will not be met and product malfunctioning or damage may occur.



## Specifications

- This device has been developed / produced for industrial use only.
- This product uses an EEPROM. The EEPROM has a service life of one million setting operations.
- Do not use this product outside the range of the specifications. Risk of an accident and product damage. There is also a risk of a noticeable reduction of service life.
- Deviations may occur in the judgment value at the bottom dead point. Do not use the bottom dead point as a standard.

## Power

- Verify that the supply voltage fluctuations are within the rating.
- If power is supplied from a commercial switching regulator, ensure that the frame ground (F.G.) terminal of the power supply is connected to an actual ground.
- Do not use during the initial transient time after the power supply is switched ON.

## Wiring

- Make sure that the power supply is OFF while performing wiring or expansion work on the controller.
- Take care that short-circuit of the load or wrong wiring may burn or damage the product.
- After you have completed wiring work, check the wiring carefully before switching on the power.
- Do not wire in parallel with a high-voltage line or power line, or run through the same conduit. Risk of malfunctioning due to induction.
- Do not apply stress such as excessive bending or pulling to the extracted part of a cable.
- When attaching the sensor head connection cable to this product, do not apply force to the product.

## Usage environment

- This product is suitable for indoor use only.
- Avoid dust, dirt, and steam.
- Do not use this sensor in places where it may come in contact with corrosive gas, etc.
- Ensure that the product does not come into contact with organic solvents such as thinner.
- Ensure that the product does not come into contact with strong acid or alkaline.
- Ensure that the product does not come into contact with oil or grease.
- This product cannot be used in an environment containing flammable or explosive gases.
- Performance may not be satisfactory in a strong electromagnetic field.
- This product is a precision device. Do not drop or otherwise subject to shock. Risk of product damage.
- Ensure that strong horizontal force is not applied to the spindle. This may cause loss of accuracy and decreased durability.

## Handling (Regular type)

- Never remove the standard rubber bellows except for replacement. Risk of product damage due to infiltration by dust, water, or other contaminants.

## Handling (Air-driven type)

- Mount a pressure-reducing valve to use the product within the allowable working pressure range. Excessive pressure may result in failure or damage.
- Do not use air containing dust, water, oil, or other foreign matter. Doing so may result in electric shock or failure. To prevent such problems, take appropriate measures such as installing air filters or mist separators.
- Do not use air containing foreign objects (such as carbon powder or dust), water, or oil. Doing so may result in electric shock or failure. To prevent such problems, take appropriate measures such as mounting air filters or mist separators.

**Other matters**

- Never attempt to disassemble, repair, or modify the product.
- When the product becomes unusable or unneeded, dispose of the product appropriately as industrial waste.

# Chapter 2 BEFORE USING THIS PRODUCT

---

2-1 Contents of Package .....	2-2
2-2 System Configuration .....	2-5
2-3 Description of Parts .....	2-6
2-3-1 Controller.....	2-6
2-3-2 Sensor Head (Regular Type) .....	2-8
2-3-3 Sensor Head (Air-Driven Type).....	2-8
2-3-4 Sensor Head Connection Cable .....	2-9

# BEFORE USING THIS PRODUCT

## 2-1 Contents of Package

The following accessories are included in the product package. Before using the product, make sure that no items are missing.

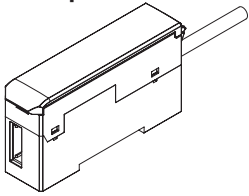
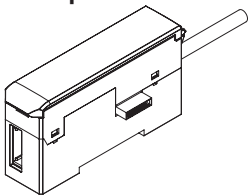
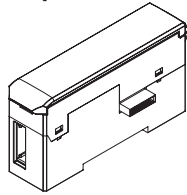
Controller
<p>HG-SC101 / Master unit, high-performance type HG-SC101-P / Master unit, high-performance type</p> <ul style="list-style-type: none"><li>• Controller: 1 pc.</li></ul>  <ul style="list-style-type: none"><li>• Instruction Manual (English / Japanese, Chinese / Korean): 2 pcs.</li><li>• General Information for Safety, Compliance, and Instructions (23 languages): 1 pc.</li></ul>
<p>HG-SC111 / Slave unit, high-performance type HG-SC111-P / Slave unit, high-performance type HG-SC112 / Slave unit, standard type HG-SC112-P / Slave unit, standard type</p> <ul style="list-style-type: none"><li>• Controller: 1 pc.</li></ul>  <ul style="list-style-type: none"><li>• Instruction Manual (English / Japanese, Chinese / Korean): 2 pcs.</li><li>• General Information for Safety, Compliance, and Instructions (23 languages): 1 pc.</li></ul>
<p>HG-SC113 / Slave unit, wire-saving type</p> <ul style="list-style-type: none"><li>• Controller: 1 pc.</li></ul>  <ul style="list-style-type: none"><li>• Instruction Manual (English / Japanese, Chinese / Korean): 2 pcs.</li><li>• General Information for Safety, Compliance, and Instructions (23 languages): 1 pc.</li></ul>

Sensor head (Regular type)
<p>HG-S1010 / General purpose, standard, 10mm type HG-S1110 / High-performance, standard, 10mm type type</p> <ul style="list-style-type: none"><li>• Sensor head: 1 pc. • Nut: 1 pc.</li></ul>   <ul style="list-style-type: none"><li>• Sensor head fastening wrench: 1 pc.</li></ul>  <ul style="list-style-type: none"><li>• Instruction Manual (English / Japanese, Chinese / Korean): 2 pcs.</li><li>• General Information for Safety, Compliance, and Instructions (23 languages): 1 pc.</li></ul>
<p>HG-S1010R / General purpose, low measuring force, 10mm type type HG-S1110R / High-performance, low measuring force, 10mm type type</p> <ul style="list-style-type: none"><li>• Sensor head: 1 pc. • Nut: 1 pc.</li></ul>   <ul style="list-style-type: none"><li>• Rubber bellows: 1 pc.</li></ul>  <ul style="list-style-type: none"><li>• Sensor head fastening wrench: 1 pc.</li></ul>  <ul style="list-style-type: none"><li>• Instruction Manual (English / Japanese, Chinese / Korean): 2 pcs.</li><li>• General Information for Safety, Compliance, and Instructions (23 languages): 1 pc.</li></ul>

## Sensor head (Regular type)

HG-S1032 / General purpose, standard, 32mm type

- Sensor head: 1 pc. • Nut: 1 pc.



- Sensor head fastening wrench: 1 pc.

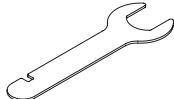

- Instruction Manual (English / Japanese, Chinese / Korean): 2 pcs.
- General Information for Safety, Compliance, and Instructions (23 languages): 1 pc.

## Sensor head (Air-driven type)

HG-S1010-AC / General purpose, air-driven type

HG-S1110-AC / High accuracy, air-driven type

- Sensor head: 1 pc. • Nut: 1 pc.



- Sensor head fastening wrench: 1 pc.

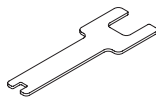

- Air tube clamp: 1 pc.



- Instruction Manual (English / Japanese, Chinese / Korean): 2 pcs.
- General Information for Safety, Compliance, and Instructions (23 languages): 1 pc.

## Sensor head connection cable

Straight connector

CN-HS-C3 / Cable length 3m

CN-HS-C7 / Cable length 7m

CN-HS-C20 / Cable length 20m

- Connection cable: 1 pc.



L-shaped connector

CN-HS-C3L / Cable length 3m

CN-HS-C7L / Cable length 7m

CN-HS-C20L / Cable length 20m

- Connection cable: 1 pc.



Note: Cannot be connected to an air-driven type.

## End plate (Option)

MS-DIN-E / End plate

- Plate: Set of 2 pcs.

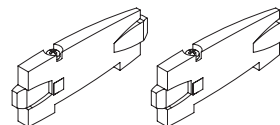

- Instruction manual

## Joint (Option)

TR-J102 / Length 15mm type

- Joint: 1 pc.



TR-J104 / Length 25mm type

- Joint: 1 pc.



## BEFORE USING THIS PRODUCT

### Probe (Option)

#### TR-S10-C×5 / Standard type

- Probe: Set of 5 pcs.



#### TR-S10-H / Super-hard type

- Probe: 1 pc.



#### TR-S321-H / Super-hard needle type

- Probe: 1 pc.



#### TR-S411-K / Flat-seated type

- Probe: 1 pc.



#### TR-S601 / Roller type

- Probe: 1 pc.



### Seal cap (Option) (Note)

#### HG-SASC×5 / Air-driven type

- Probe: Set of 5 pcs.



Note: Cannot be connected to a regular type.

### Rubber bellows (Option)

#### TR-G20×5 / 10mm type

- Bellows: Set of 5 pcs.



#### TR-G40×5 / 32mm type

- Bellows: Set of 5 pcs.

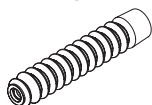

Note: Cannot be connected to an air-driven type.

## 2-2 System Configuration

The **HG-S** series consists of controllers, sensor head connection cables, and sensor heads.  
 For the controllers, master units (2 types) and slave units (5 types) are available. Up to 15 slave units can be connected per master unit. (When communication unit consolidated: up to 14 slave units)  
 For the sensor heads, 7 types are available.



- When connecting slave units to a master unit, connect only NPN output types, or only PNP output types. Dissimilar output types cannot be connected together.
- To use an air-driven type sensor head, connect to an **HG-SC** series controller manufactured in February 2019 or later.

Sensor head connection cable  
 Straight connector

**CN-HS-C3** / Cable length 3m

**CN-HS-C7** / Cable length 7m

**CN-HS-C20** / Cable length 20m

L-shaped connector

**CN-HS-C3L** / Cable length 3m

**CN-HS-C7L** / Cable length 7m

**CN-HS-C20L** / Cable length 20m

Controller - Slave unit

**HG-SC111** / High-performance, NPN output type

**HG-SC111-P** / High-performance, PNP output type

**HG-SC112** / Standard, NPN output type

**HG-SC112-P** / Standard, PNP output type

**HG-SC113** / Wire-saving

Controller - Master unit

**HG-SC101** / NPN output type

**HG-SC101-P** / PNP output type

Sensor head

**HG-S1010** /

General purpose, standard, 10mm type

**HG-S1010R** /

General purpose, low measuring force, 10mm type

**HG-S1110** /

High-performance, standard, 10mm type

**HG-S1110R** /

High-performance, low measuring force, 10mm type

**HG-S1032** /

General purpose, standard, 32mm type

**HG-S1010-AC** /

General purpose, air-driven type

**HG-S1110-AC** /

High accuracy, air-driven type

## BEFORE USING THIS PRODUCT

### 2-3 Description of Parts

#### 2-3-1 Controller

HG-SC101 / Master unit, high-performance type  
 HG-SC101-P / Master unit, high-performance type

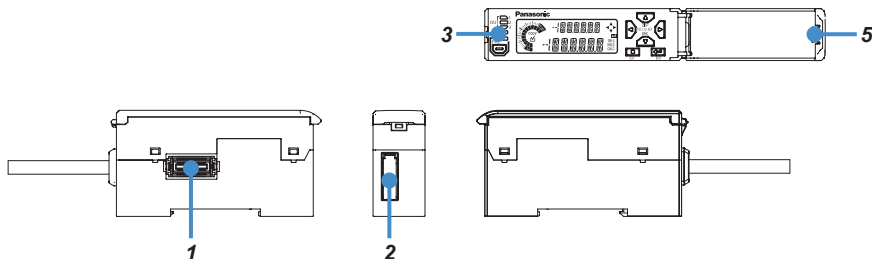

HG-SC111 / Slave unit, high-performance type  
 HG-SC111-P / Slave unit, high-performance type  
 HG-SC112 / Slave unit, standard type  
 HG-SC112-P / Slave unit, standard type

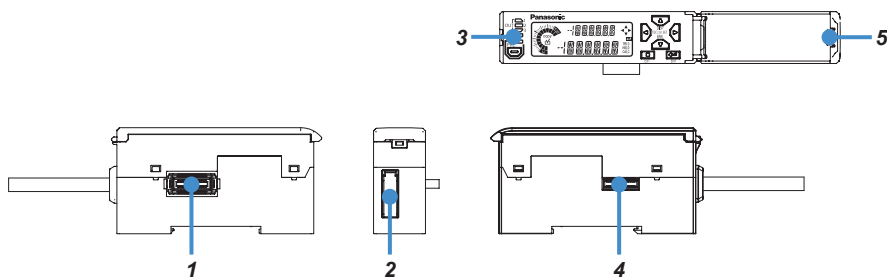

HG-SC113 / Slave unit, wire-saving type

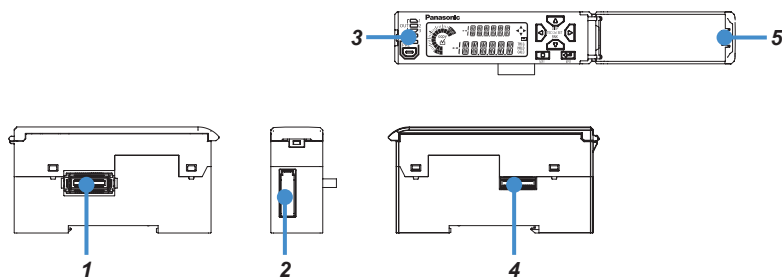

	Name	Function
1	Female connector	For connection to a slave unit. Remove the connector cover before connecting to a slave unit.
2	Sensor head connection cable connector	Connects a sensor head connection cable (option).
3	Digital display / operation unit	For details, refer to the following page.
4	Male connector	For connection to a master unit or slave unit.
5	Digital display / operation cover	Keep closed when not using.



## • Digital display / operation unit

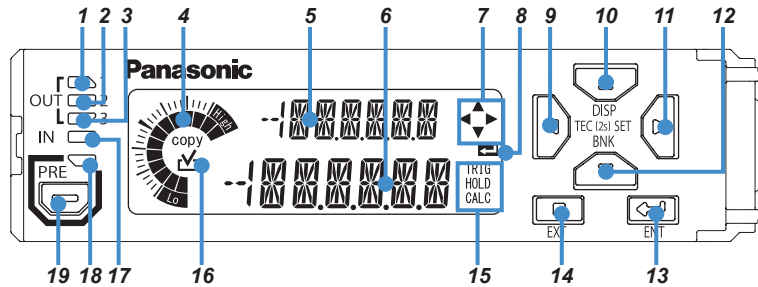

Name		Function	
1	Output 1 indicator (Orange)	Lights up when output 1 is ON.	
2	Output 2 indicator (Orange)	Lights up when output 2 is ON.	
3	Output 3 indicator (Orange)	Lights up when output 3 is ON.	
4	Circle meter (Orange, Green)	<ul style="list-style-type: none"> <li>Shows increases / decreases of the judgment value by meter display.</li> <li>The lowest two gradations show the LOW judgment, and the highest two gradations show the HIGH judgment.</li> <li>Green lights up when the judgment is GO. Orange lights up when the judgment is LOW / HIGH.</li> <li>When the HIGH setting is set to a lower value than the LOW setting, all indicators turn OFF.</li> <li>To show the count, long-press the LEFT / RIGHT / UP / DOWN key for 2 seconds in the base screen.</li> <li>The number of setting items in the level lights up, and the order of the setting times is shown by blinking.</li> </ul>	
5	Digital display / SUB (Green)	Shows the setting item. The item set using display switching mode appears.	
6	Digital display / MAIN (White)	Shows the judgment value and setting data.	
7	Guide mark / arrow key (White)	Lights up when the LEFT / RIGHT / UP / DOWN key is enabled while configuring settings.	
8	Guide mark / ENT (White)	Lights up when the ENTER key is enabled while configuring settings.	
9	LEFT key	<ul style="list-style-type: none"> <li>Use to change setting items and settings when configuring settings, and to move through set value digits.</li> <li>Long-press for 2 seconds in the base screen to enter teaching mode.</li> </ul>	
10	UP key	<ul style="list-style-type: none"> <li>Use to change setting items when configuring settings, and to change numeric set values.</li> <li>Long-press for 2 seconds in the base screen to enter display switching mode.</li> <li>Short-press in the base screen to finely adjust the HIGH set value.</li> </ul>	
11	RIGHT key	<ul style="list-style-type: none"> <li>Use to change setting items and settings when configuring settings, and to move through set value digits.</li> <li>Long-press for 2 seconds in the base screen to enter setting mode.</li> </ul>	
12	DOWN key	<ul style="list-style-type: none"> <li>Use to change setting items when selecting settings, and to change numeric set values.</li> <li>Long-press for 2 seconds in the base screen to enter bank mode.</li> <li>Short-press in the base screen to finely adjust the LOW set value.</li> </ul>	
13	ENTER key	<ul style="list-style-type: none"> <li>Use to select setting items and finalize settings when configuring settings.</li> <li>Long-press for 3 seconds together with the EXIT key in the base screen to activate or cancel key lock.</li> </ul>	
14	EXIT key	<ul style="list-style-type: none"> <li>Use to exit a setting item or cancel a setting when configuring settings.</li> <li>Long-press for 3 seconds together with the ENTER key in the base screen to activate or cancel key lock.</li> </ul>	
15	Status mark	TRIG (White)	Lights up while the trigger input (external input) is ON. Lights up during sampling when self-hold is set.
		HOLD (White)	Lights up while the judgment value is held.
		CALC (White)	Lights up when set to calculation mode with a slave unit connected.
16	Copy checkmark (Orange)	When configuring master unit settings, "COPY" lights up for setting items that can be copied to slave units. A checkmark lights up for items selected for copying, and the settings are copied when copying is executed.	
17	Input indicator (White)	Lights up when external input 1, 2, or 3 is ON.	
18	Preset indicator (Green)	Lights up when the preset function is used.	
19	Preset key	When short-pressed in the base screen, the preset function turns ON. When long-pressed for 2 seconds in the base screen, the preset function turns OFF.	

## BEFORE USING THIS PRODUCT

### 2-3-2 Sensor Head (Regular Type)

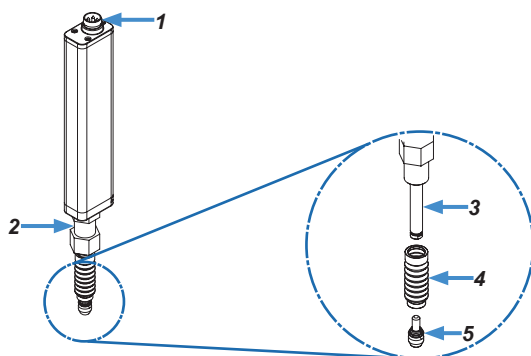

	Name	Function
1	Sensor head connection cable connector	Connects the sensor head connection cable.
2	Fastener	Fastens the sensor head using the provided nut.
3	Spindle	Detects the amount of movement.
4	Rubber bellows	Protects the spindle.
5	Probe	Ceramic measurement probe.

### 2-3-3 Sensor Head (Air-Driven Type)

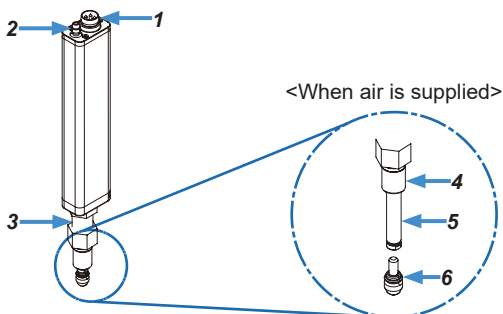

	Name	Function
1	Sensor head connection cable connector	Connects the sensor head connection cable.
2	Air tube joint	Connects the air tube.
3	Fastener	Fastens the sensor head using the provided nut.
4	Seal cap	Protects the spindle.
5	Spindle	Detects the amount of movement.
6	Probe	Ceramic measurement probe.

**2-3-4 Sensor Head Connection Cable**

Straight connector

**CN-HS-C3** / Cable length 3m

**CN-HS-C7** / Cable length 7m

**CN-HS-C20** / Cable length 20m

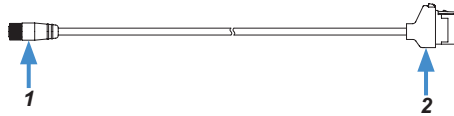

L-shaped connector (Note)

**CN-HS-C3L** / Cable length 3m

**CN-HS-C7L** / Cable length 7m

**CN-HS-C20L** / Cable length 20m

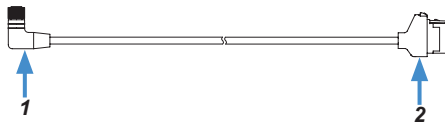

	Name	Function
<b>1</b>	Sensor head connector	Connects to the sensor head cable connector on the sensor head.
<b>2</b>	Controller connector	Connects to the sensor head cable connector on the controller.

Note: Cannot be connected to an air-driven type.

(MEMO)

# Chapter 3 INSTALLATION AND CONNECTIONS

---

3-1 Mounting the Controller .....	3-2
3-1-1 Mounting on a DIN Rail .....	3-2
3-1-2 Removing from a DIN Rail .....	3-2
3-2 Attaching the Sensor Head .....	3-3
3-3 Wiring the Controller Connector on the Sensor Head Connection Cable .....	3-5
3-3-1 Disassembly Procedure .....	3-5
3-3-2 Wiring Procedure .....	3-5
3-4 Connecting the Controller and Sensor Head .....	3-7
3-4-1 Attaching the Sensor Head and Sensor Head Connection Cable .....	3-7
3-4-2 Removing the Sensor Head and Sensor Head Connection Cable .....	3-8
3-4-3 Connecting the Air Tube (Air-Driven Type Only) .....	3-9
3-4-4 Disconnecting the Air Tube (Air-Driven Type Only) .....	3-9
3-4-5 Air Circuit (Recommended) (Air-Driven Type Only) .....	3-10
3-4-6 Attaching the Controller and Sensor Head Connection Cable .....	3-11
3-4-7 Removing the Controller and Sensor Head Connection Cable .....	3-11
3-5 Connecting Controllers .....	3-12
3-5-1 Connection Method .....	3-13
3-5-2 Removal Method .....	3-15
3-6 Connection Diagrams and I/O Circuit Diagrams .....	3-16
3-6-1 Connection Diagrams .....	3-16
3-6-2 I/O Circuit Diagrams .....	3-18

# INSTALLATION AND CONNECTIONS

## 3-1 Mounting the Controller

### 3-1-1 Mounting on a DIN Rail

1. Insert the rear of the mounting part into the DIN rail.
2. While pressing down on the rear of the mounting part, insert the front of the mounting part into the DIN rail.

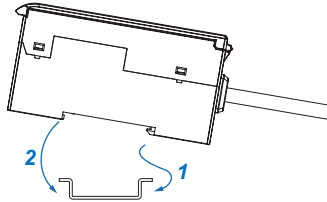

### 3-1-2 Removing from a DIN Rail

1. Grasp the product and push forward.
2. Lift the front to remove.

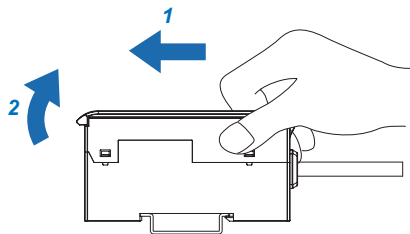

## 3-2 Attaching the Sensor Head

- Sensor head accessories

### Sensor head fastening wrench

10mm type  
Air-driven type

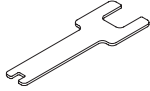

32mm type



### Mounting nut



1. Open a hole in the housing in which the sensor head will be mounted.

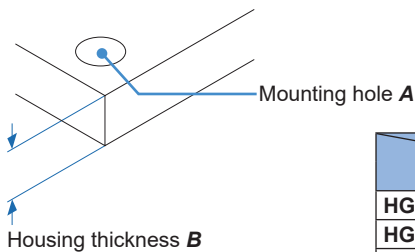

	Housing thickness	Mounting hole
	<b>A</b>	<b>B</b>
HG-S1010(R), HG-S1110(R)	ø8H7( <sup>+0.015</sup> <sub>0</sub> )mm	6.5 to 12.5mm
HG-S1010-AC, HG-S1110-AC		
HG-S1032	ø12H7( <sup>+0.018</sup> <sub>0</sub> )mm	6.5 to 10.5mm

2. Insert the sensor head into the hole you opened in the housing, and fasten provisionally with the provided mounting nut.

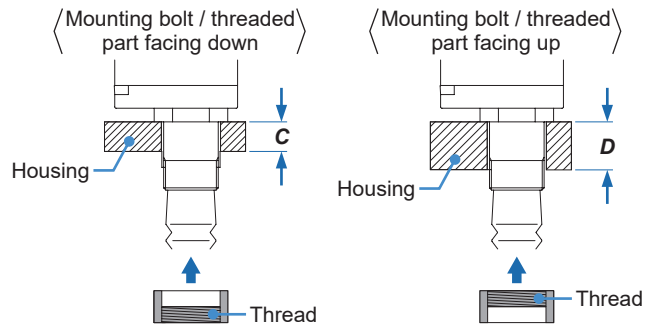
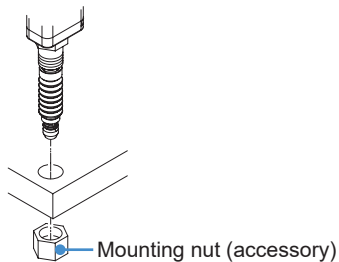

	Housing thickness	
	<b>C</b>	<b>D</b>
HG-S1010(R), HG-S1110(R)	6.5 to 10mm	10 to 12.5mm
HG-S1010-AC, HG-S1110-AC		
HG-S1032	6.5 to 8.5mm	8.5 to 10.5mm

## INSTALLATION AND CONNECTIONS

### 3. Fasten the sensor head.

When fastening the sensor head, tighten the mounting nut with a wrench while holding the sensor head in place with the provided sensor head fastening wrench as shown below. Tighten to a torque of 12.5N·m or less (**HG-S1032**: 15N·m or less).

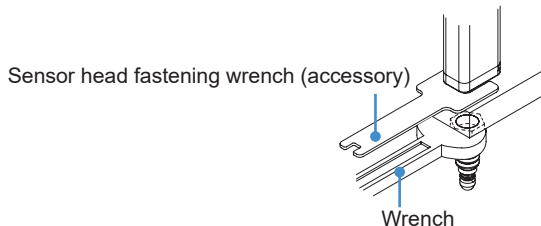

When tightening the mounting nut on the regular type, take care not to damage the rubber bellows.

### 4. On the regular type, make sure that the rubber bellows have not become deformed as shown below.

If the rubber bellows is deformed, rotate the bellows to restore to the normal shape.

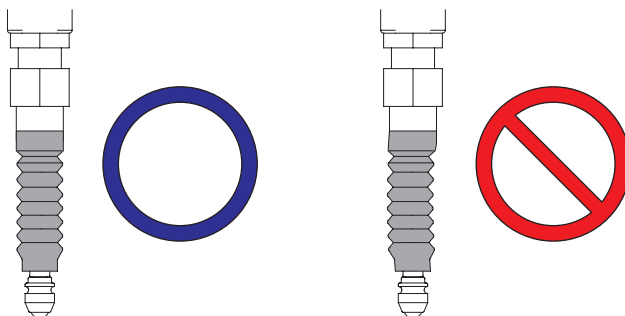

If the rubber bellows is deformed, a load will occur when the spindle operates and damage may result.



## 3-3 Wiring the Controller Connector on the Sensor Head Connection Cable

### 3-3-1 Disassembly Procedure

1. Slide the protective cover in the direction of the arrow.

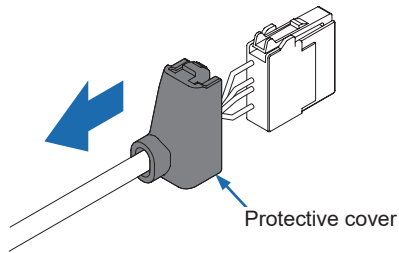

2. Press down on the wire insertion hole lever (white) with a flat-head screwdriver (tip width 2mm or less), and remove the wire.

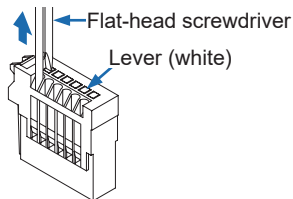

### 3-3-2 Wiring Procedure

1. Using the "STRIP GAUGE" on the side of the unit, strip the wire so that the core wire length is 7 to 8mm, and twist the core wires several times.

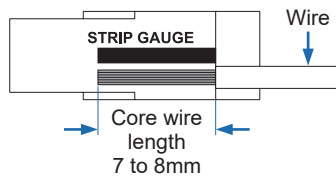

2. Using a flat-head screwdriver with a tip width of 2mm or less, press down until the lever (white) on the operation unit until the lever locks.

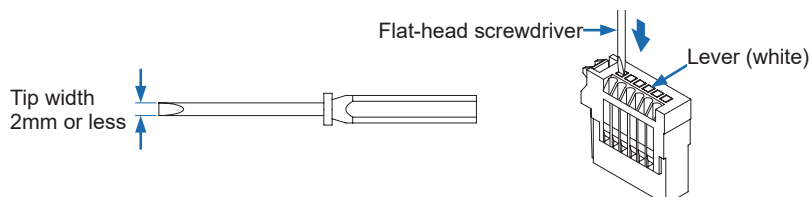

## INSTALLATION AND CONNECTIONS

- 3.** Insert the wire firmly into the wire insertion hole. Make sure that the jacketed part of the wire has entered the wire insertion hole and the tips of the core wires have passed through the connection part as shown below.

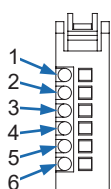
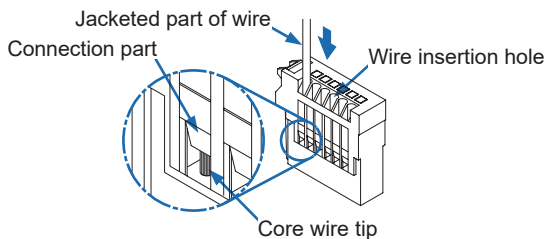

Terminal No.	Connection cable
1	Red
2	—
3	White
4	Green
5	—
6	Black

- 4.** Insert the tip of the flat-head screwdriver into the release hole so that it contacts the bottom of the lever (white), and move the tip of the flat-head screwdriver up. The lever (white) will make a "click" sound when it returns to its original position, and the wire will be locked.

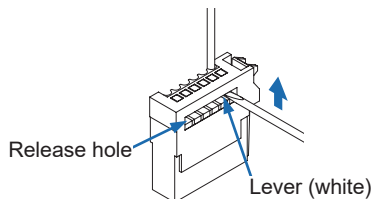

- 5.** Pull on the wire gently to ensure that it does not come out.

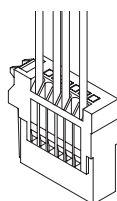

- 6.** Slide the protective cover in the direction of the arrow to return the cover to its original position.

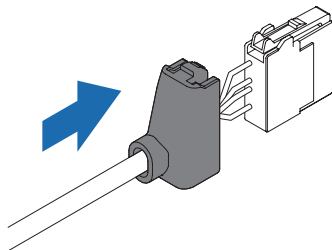

## 3-4 Connecting the Controller and Sensor Head

Connect the controller and the sensor head using the sensor head connection cable **CN-HS-C□** / **CN-HS-C□L**.

### 3-4-1 Attaching the Sensor Head and Sensor Head Connection Cable

- After attaching the connector, verify that the connector is firmly tightened. If loose, the connector may come off and an error will result.
- When attaching the sensor head connection cable to this product, take care not to apply force to the product.
- The L-shaped **CN-HS-C□L** connector cannot be connected to an air-driven type.

1. Insert the sensor head connection cable into the connector for the sensor head connection cable on the sensor head.
2. Turn the fastening ring on the sensor head connector in the direction shown and tighten firmly.

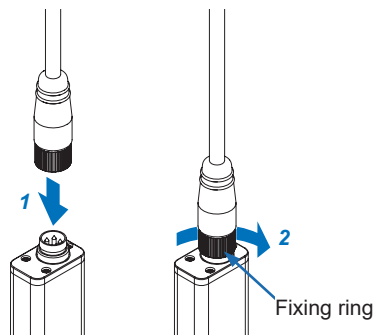

- Do not turn the connector on the L-shaped connector **CN-HS-C□L**. Risk of damage.

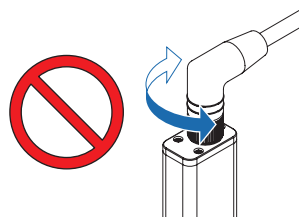

## INSTALLATION AND CONNECTIONS

---

### 3-4-2 Removing the Sensor Head and Sensor Head Connection Cable

1. Turn the fastening ring on the sensor head connector in the direction of the arrow to loosen the ring.
2. Grasp the sensor head connector and pull up to remove.

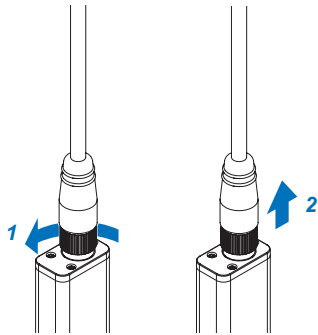

- When disconnecting, always make sure that the fastening ring has been completely loosened before pulling out the cable. Risk of damage if you pull the cable with excessive force (15N or more) with the fastening ring tightened.
- If changing the type of sensor head to be connected, always switch the power OFF then ON.

### 3-4-3 Connecting the Air Tube (Air-Driven Type Only)

1. While loosening the air tube clamp, slide it from the tip of the air tube and then release it when it reaches halfway through the tube.
2. Insert the tip of the air tube until it reaches the root of the joint on the sensor head.
3. Move the air tube clamp and secure the tip of the air tube.

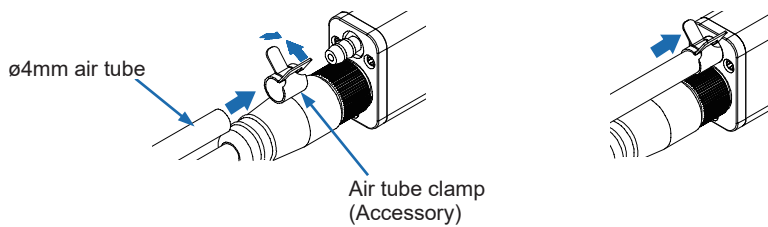

### 3-4-4 Disconnecting the Air Tube (Air-Driven Type Only)

1. While loosening the air tube clamp, move it halfway through the air tube.
2. Grasp the sensor head and pull out the air tube.

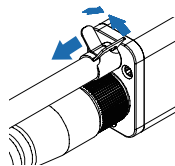

Note: Take care not to lose the air tube clamp.

## INSTALLATION AND CONNECTIONS

### 3-4-5 Air Circuit (Recommended) (Air-Driven Type Only)

#### <Reference>

Create an air circuit like the one (recommended) shown in the figure below and, if necessary, adjust the speed of the spindle with the speed control valve.

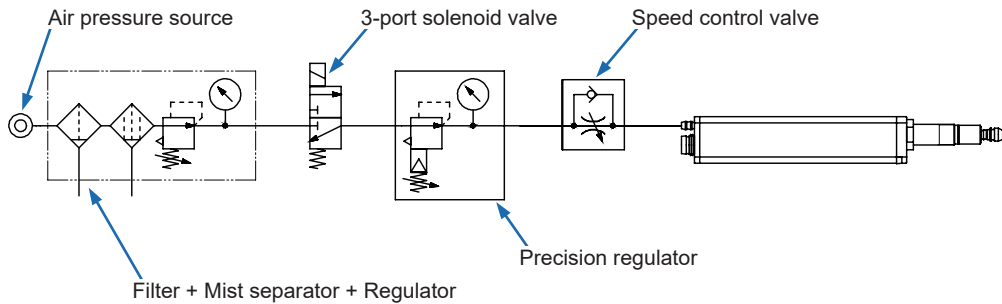

- Notes:
- 1) Supply clean air (free from moisture, oil, dust, or other foreign matter) to this product.
  - 2) Air pressure may decrease, depending on the length of the air pipe from the air supply source or any pneumatic components (such as needle valves, speed controllers, or mini-filters) that are added. Take care to ensure that air pressure supply to the product is sufficient. Select pneumatic components suitable for the supplied air pressure.
  - 3) The 3-port solenoid valve and speed control valve have their respective mounting directions. Mount each valve in their correct direction by referring to the above diagram.
  - 4) A filter with a rated filtration of  $5\mu\text{m}$  or less and a mist separator with a rated filtration of  $0.3\mu\text{m}$  or less are recommended.

### 3-4-6 Attaching the Controller and Sensor Head Connection Cable

Insert the controller connector on the sensor head connection cable into the connector for the sensor head connection cable on the controller.

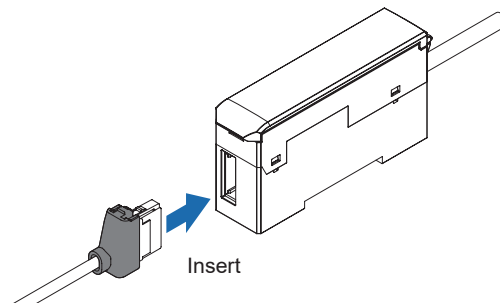

 Insert the connector firmly. Risk of sensor head or controller damage if not completely connected.

### 3-4-7 Removing the Controller and Sensor Head Connection Cable

Grasp the controller, and while pressing on the lock release lever on the controller connector of the sensor head connection cable, pull toward you to disconnect.

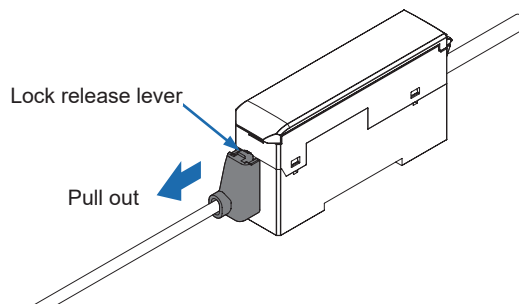

 If you attempt to disconnect the cable by pulling it without pressing the lock release lever, cable wire breakage and connector damage may occur.

# INSTALLATION AND CONNECTIONS

## 3-5 Connecting Controllers

- Always shut OFF the power before connecting a slave unit to or disconnecting a slave unit from the master unit. Risk of controller damage if you attempt connection or removal with the power ON.
  - Insert the male connector firmly into the female connector. Risk of controller damage if not completely connected.
  - When connecting slave units to a master unit, connect only NPN output types, or only PNP output types. Dissimilar output types cannot be connected together.
  - An **HG-SC** series controller manufactured in January 2019 or earlier cannot be used together with an **HG-TC** series controller. To use these controllers together, use an **HG-SC** series controller manufactured in February 2019 or later.
- ! ● To connect units, the units must be mounted on a DIN rail. Attach end plates **MS-DIN-E** (optional) so as to enclose the connected units at the ends.

### <Reference>

- Up to 15 slave units can be connected per master unit. (When communication unit consolidated: up to 14 slave units)
- If **HG-SC** series controllers and **HG-TC** series controllers are used in combination, connect a slave unit of the same series as the master unit to the side near the master unit and a slave unit of a different series to the far side.

**Example: When the master unit is an HG-SC**

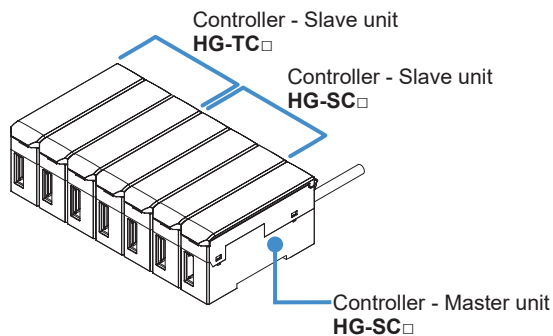

- If **HG-SC** series controllers and **HG-TC** series controllers are used in combination, there are limitations on the functions below.

	Item	Description of limitation
1	Calculation function	Calculation is only performed when the slave unit is the same series as the master unit. Calculation is not performed when the slave unit series is different from the master unit series. "CALC" does not appear in the display of a slave unit of a different series.
2	Input all	The master unit only performs input all when the slave unit is the same series. A slave unit of a different series than the master unit is not input even when the external input settings match those of the master unit.
3	Copy function	Copying is only performed when the slave unit is the same series as the master unit. "NOW COPY" appears on the displays of the master unit and slave unit when the slave unit is a different series from the master unit, but copying is not performed.



## 3-5-1 Connection Method

To mount a controller, refer to "3-1 Mounting the Controller".

1. Mount one master unit on the DIN rail.

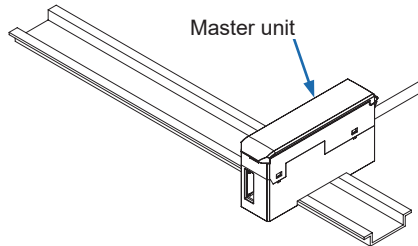

2. Remove the connector cover.

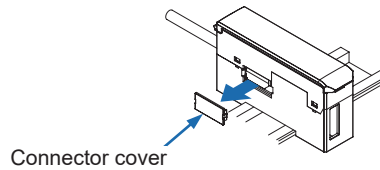

3. Mount each slave unit one at a time on the DIN rail. Remove all connector covers except for the cover on the end slave unit.

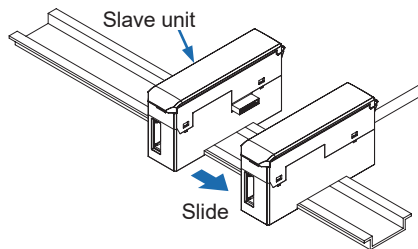

4. Slide each slave unit to connect the female and male connectors.

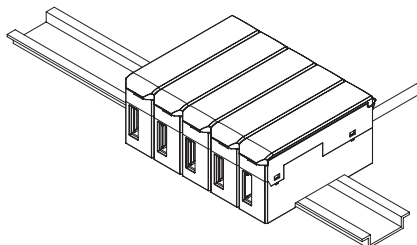

## INSTALLATION AND CONNECTIONS

---

- 5.** Attach end plates **MS-DIN-E** (optional) with the flat side facing in so as to enclose the connected units at the ends.

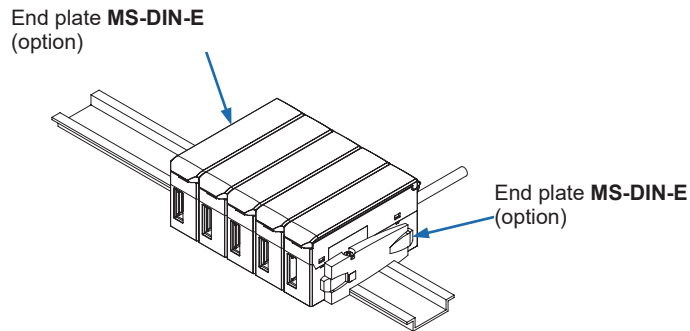

- 6.** Tighten the screws to fasten the end plates.  
The tightening torque should be  $0.3\text{N}\cdot\text{m}$  or less.



Take care if the screw is tightened with a torque of  $0.3\text{N}\cdot\text{m}$  or more, this product may get damaged.

### 3-5-2 Removal Method

1. Loosen the screws on the end plates
2. Remove the end plates.
3. Slide and remove the controllers, one at a time.

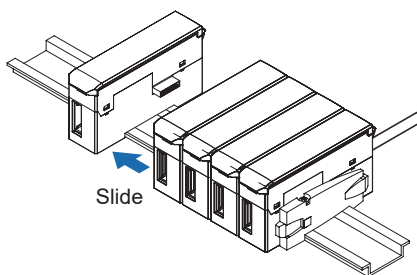

# INSTALLATION AND CONNECTIONS

## 3-6 Connection Diagrams and I/O Circuit Diagrams

### 3-6-1 Connection Diagrams

#### ● HG-SC101, HG-SC101-P

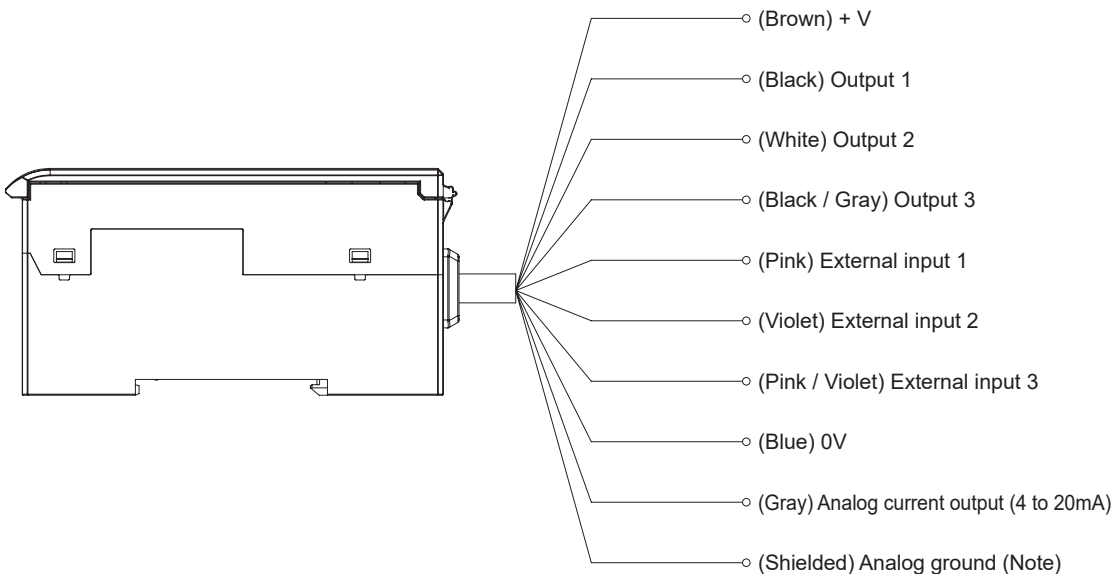

Note: Use shielded wire for the analog output.

#### ● HG-SC111, HG-SC111-P

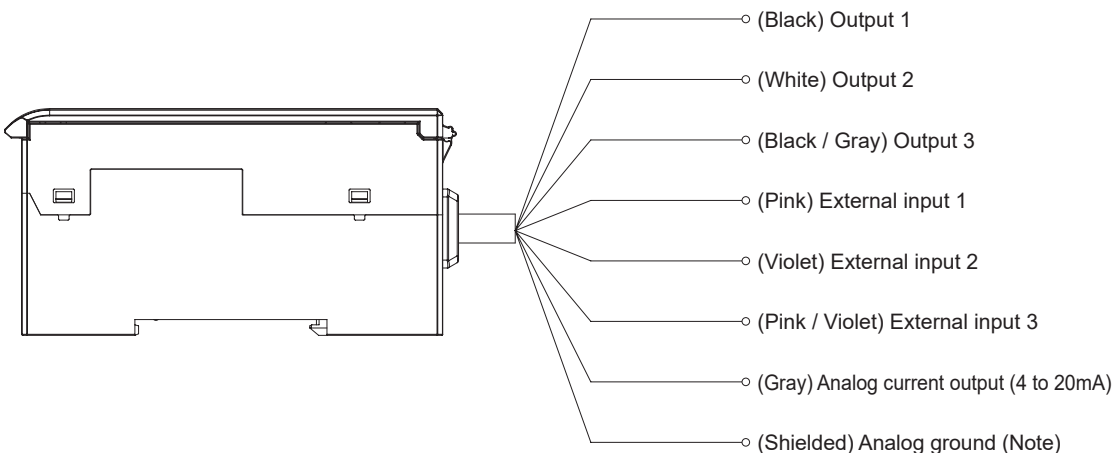

Note: Use shielded wire for the analog output.

#### <Reference>

The **HG-SC111** and **HG-SC111-P** cables do not have +V or 0V. Power is supplied from the connector of the master unit.

## INSTALLATION AND CONNECTIONS

- HG-SC112, HG-SC112-P

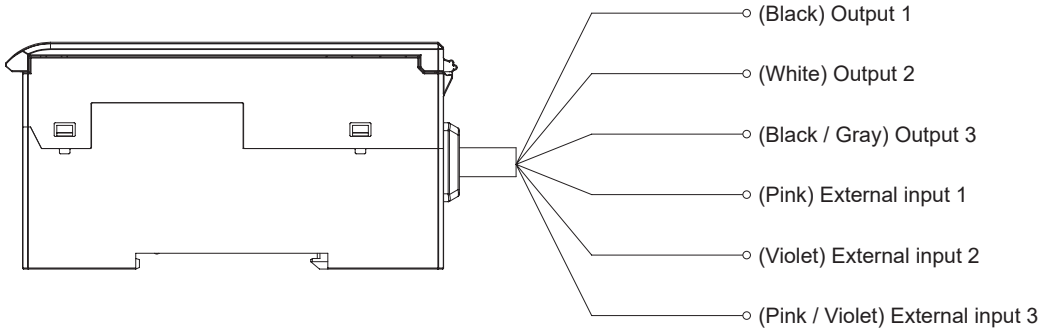

**<Reference>**

The **HG-SC112** and **HG-SC112-P** cables do not have +V or 0V. Power is supplied from the connector of the master unit.

# INSTALLATION AND CONNECTIONS

## 3-6-2 I/O Circuit Diagrams

### ● HG-SC101 / NPN output type

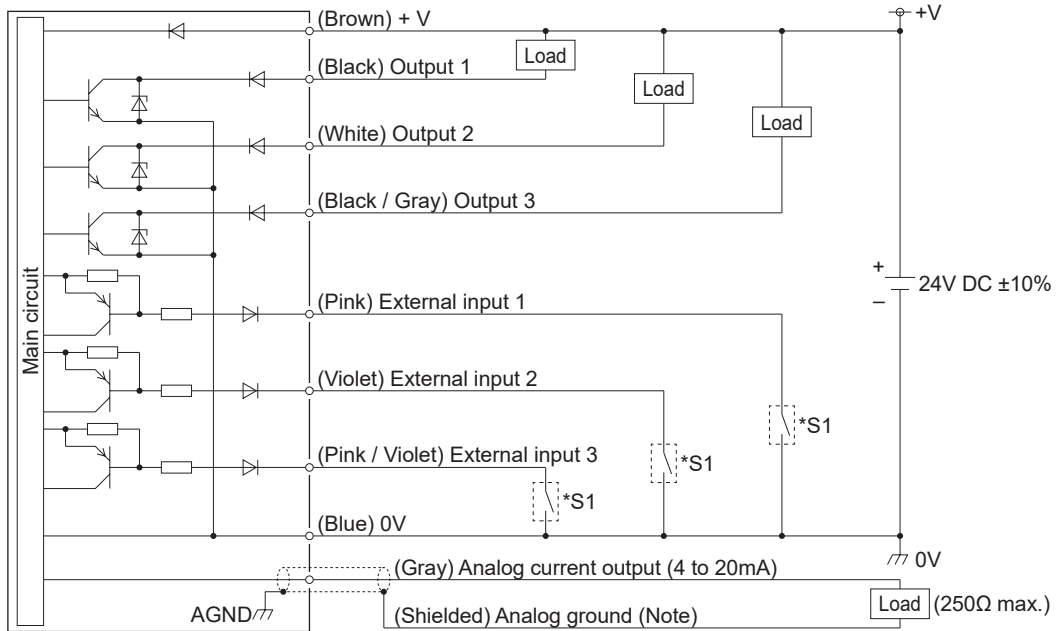

\*S1

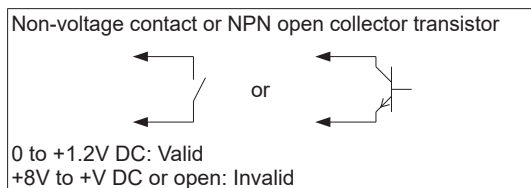

Note: Use shielded wire for the analog output.

### <Reference>

All outputs are equipped with short-circuit protection. If any one of outputs 1 to 3 short-circuits, all outputs temporarily turn OFF. The outputs automatically recover when the short-circuit state is cleared.

# INSTALLATION AND CONNECTIONS

## ● HG-SC101-P / PNP output type

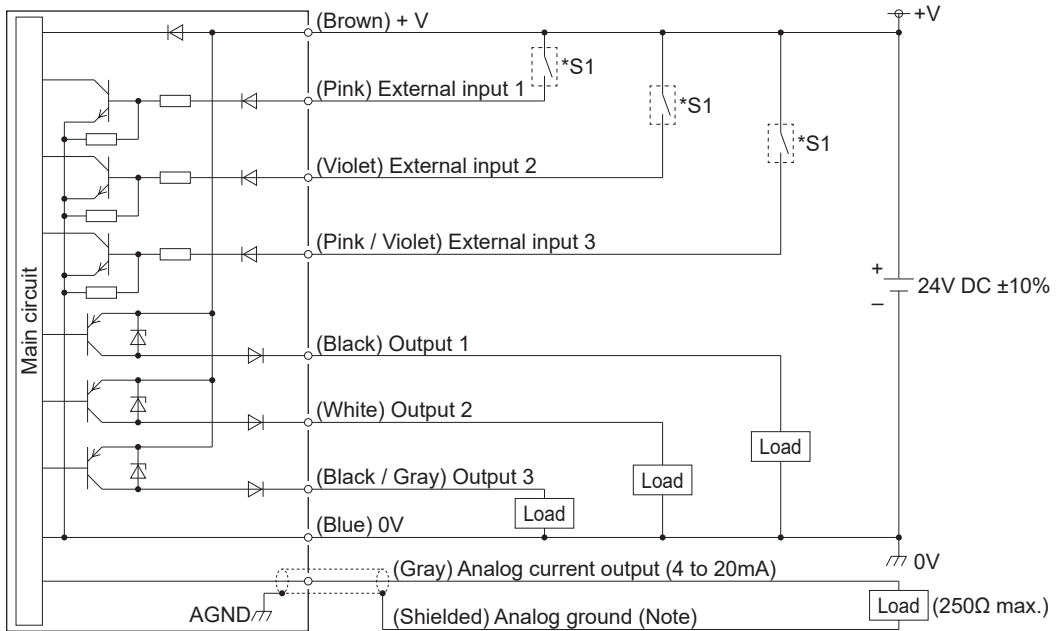

\*S1

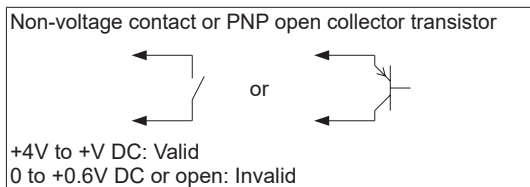

Note: Use shielded wire for the analog output.

### <Reference>

All outlets are equipped with short-circuit protection. If any one of outputs 1 to 3 short-circuits, all outputs temporarily turn OFF. The outputs automatically recover when the short-circuit state is cleared.

# INSTALLATION AND CONNECTIONS

## ● HG-SC111 / NPN output type

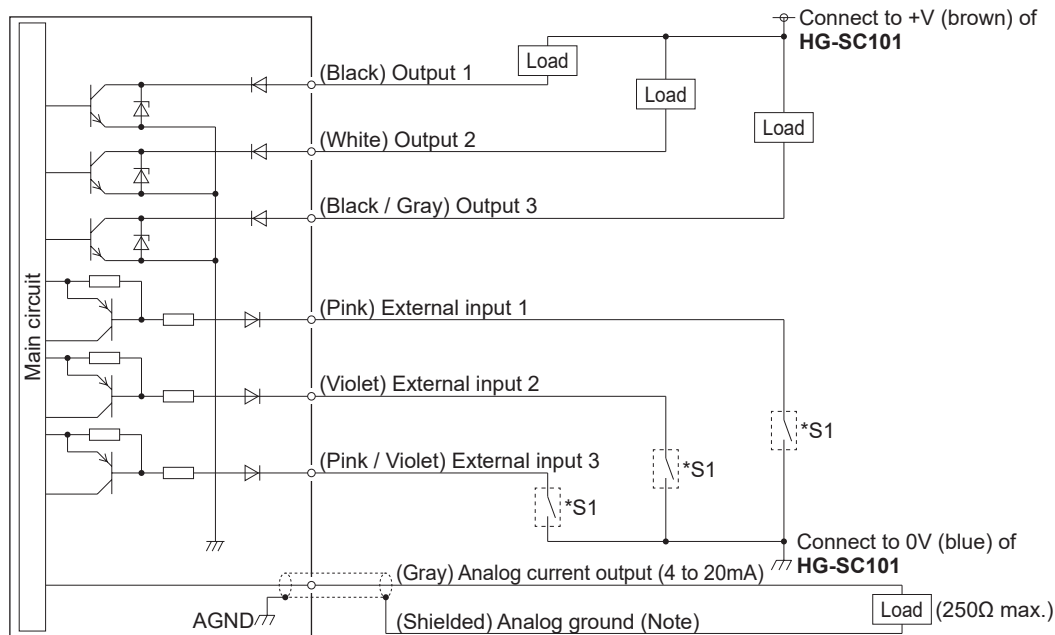

\*S1

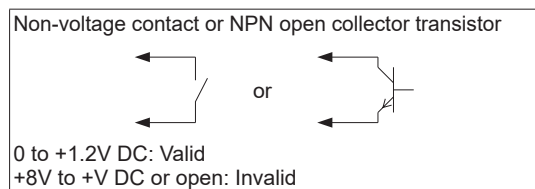

Note: Use shielded wire for the analog output.

### <Reference>

- All outlets are equipped with short-circuit protection. If any one of outputs 1 to 3 short-circuits, all outputs temporarily turn OFF. The outputs automatically recover when the short-circuit state is cleared.
- The **HG-SC111** cable does not have +V or 0V. Power is supplied from the connector of the master unit.



## ● HG-SC111-P / PNP output type

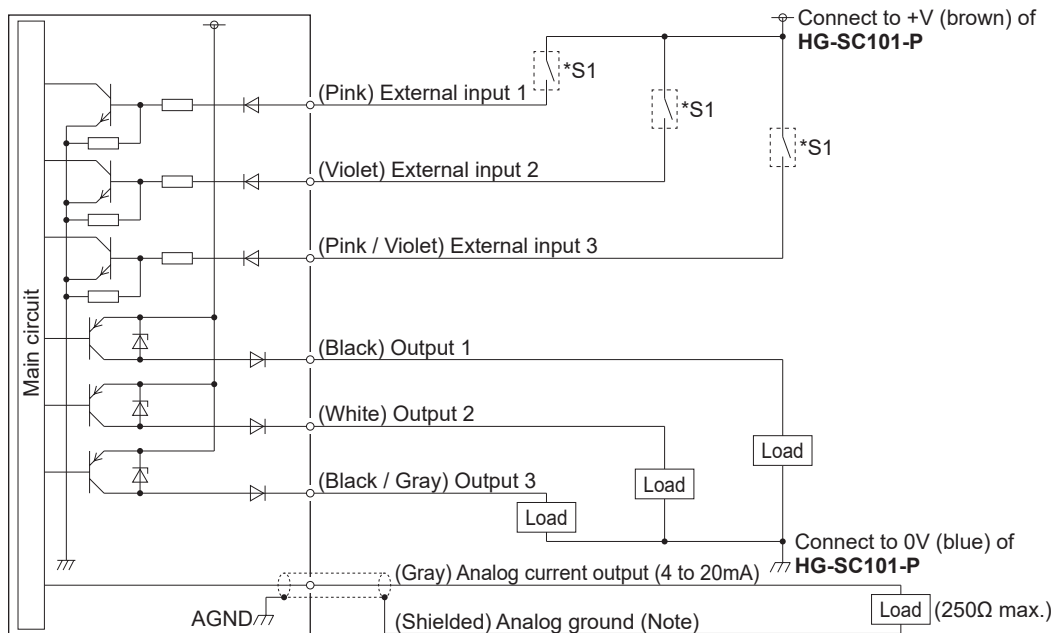

\*S1

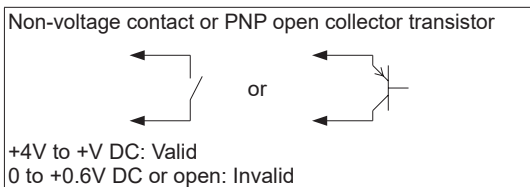

Note: Use shielded wire for the analog output.

### <Reference>

- All outlets are equipped with short-circuit protection. If any one of outputs 1 to 3 short-circuits, all outputs temporarily turn OFF. The outputs automatically recover when the short-circuit state is cleared.
- The **HG-SC111-P** cable does not have +V or 0V. Power is supplied from the connector of the master unit.

# INSTALLATION AND CONNECTIONS

## ● HG-SC112 / NPN output type

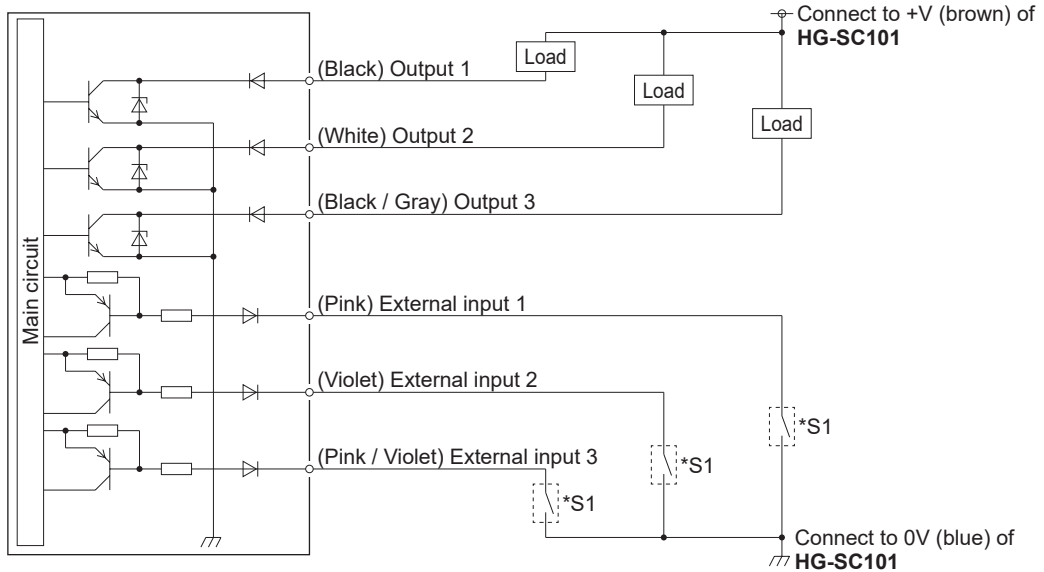

\*S1

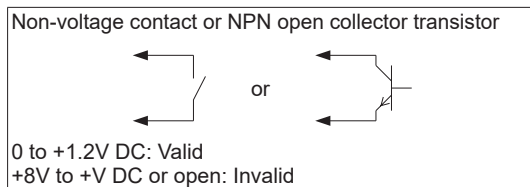

Note: Use shielded wire for the analog output.

### <Reference>

- All outlets are equipped with short-circuit protection. If any one of outputs 1 to 3 short-circuits, all outputs temporarily turn OFF. The outputs automatically recover when the short-circuit state is cleared.
- The **HG-SC112** cable does not have +V or 0V. Power is supplied from the connector of the master unit.

## ● HG-SC112-P / PNP output type

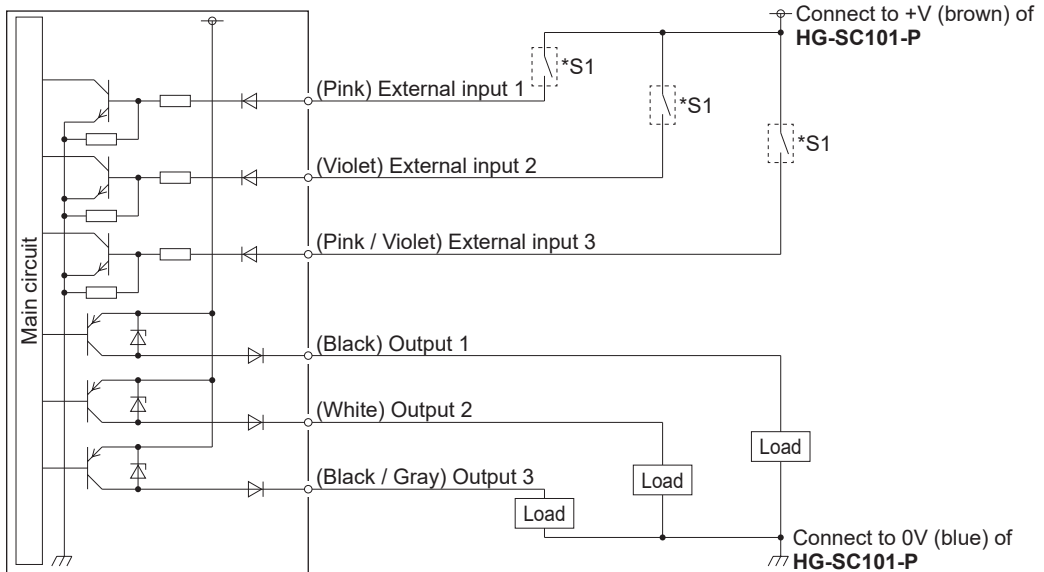

\*S1

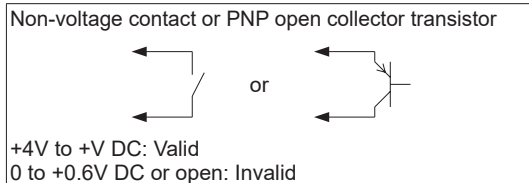

Note: Use shielded wire for the analog output.

### <Reference>

- All outlets are equipped with short-circuit protection. If any one of outputs 1 to 3 short-circuits, all outputs temporarily turn OFF. The outputs automatically recover when the short-circuit state is cleared.
- The HG-SC112-P cable does not have +V or 0V. Power is supplied from the connector of the master unit.

(MEMO)

# Chapter 4 BASIC OPERATION

---

4-1 Explanation of Basic Operation .....	4-2
4-1-1 From Power ON to Mode Selection .....	4-2
4-1-2 Operation Keys and Display .....	4-3
4-2 Explanation of Modes .....	4-5
4-2-1 Display Switching Mode .....	4-5
4-2-2 Presets .....	4-8
4-2-3 Teaching Mode .....	4-11
4-2-4 Bank Mode .....	4-20
4-2-5 Key Lock .....	4-24

# BASIC OPERATION

## 4-1 Explanation of Basic Operation

### 4-1-1 From Power ON to Mode Selection

This section explains the modes and shortcut functions that can be used from the home screen after the power is turned ON.

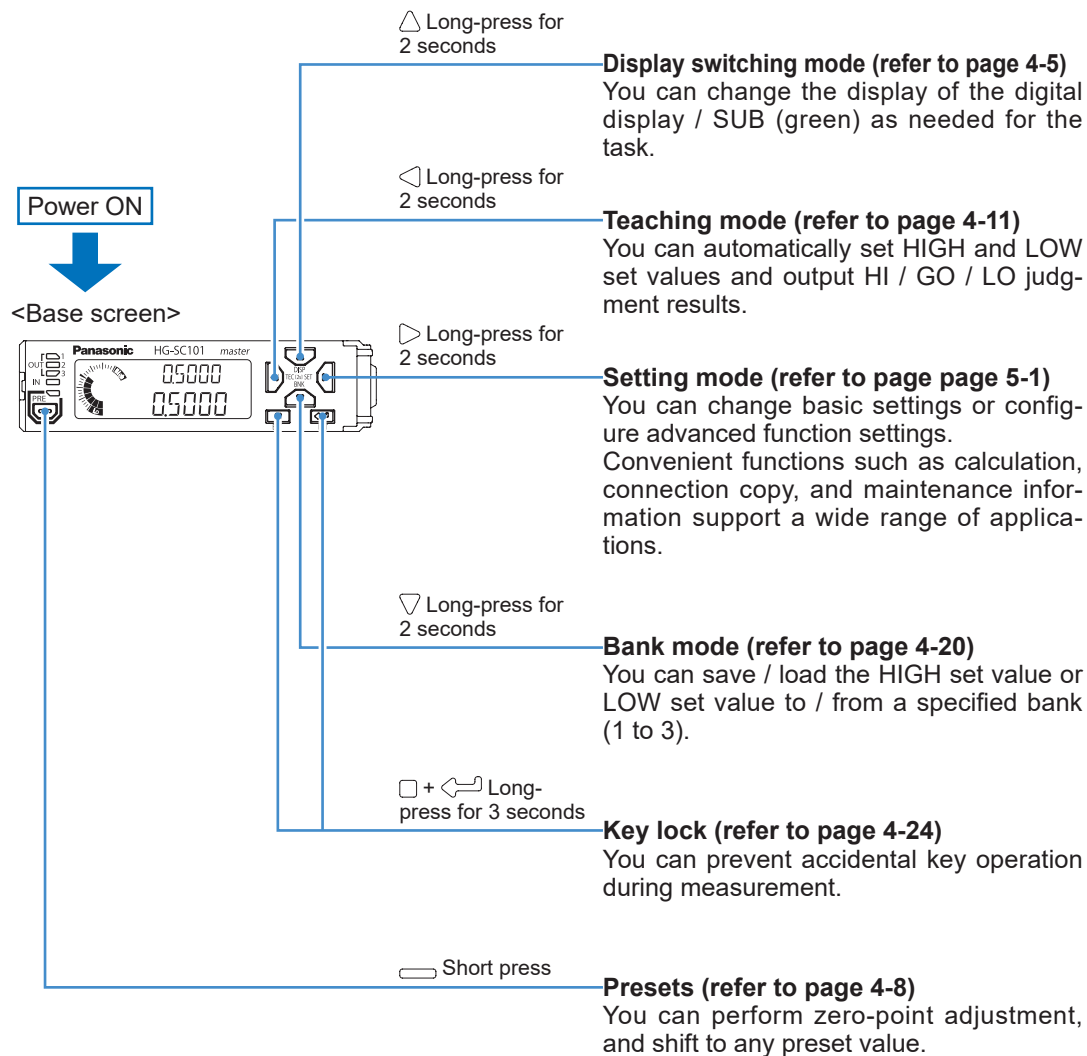

**4-1-2 Operation Keys and Display**

**■ Operation Keys**

The operation keys are as follows.

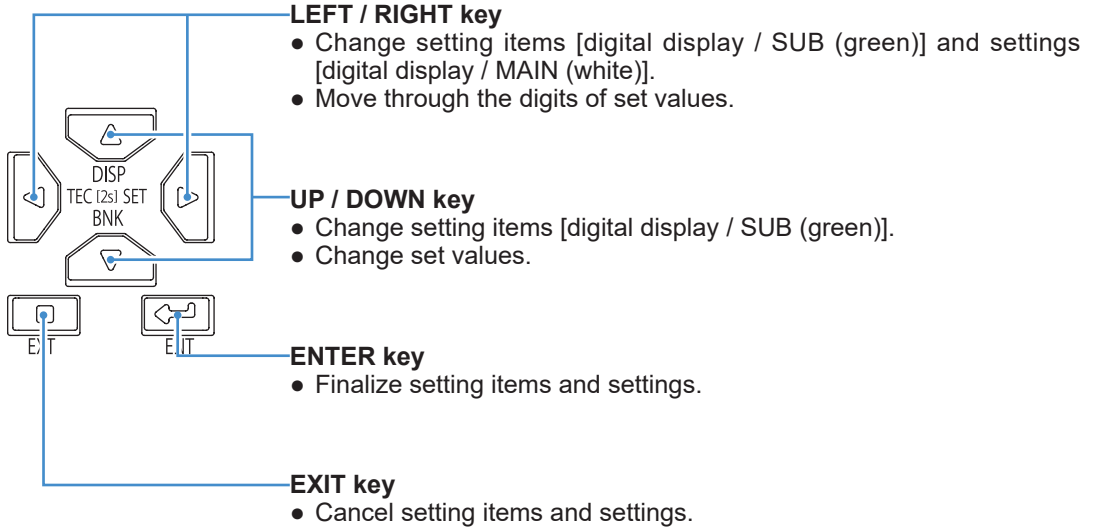

# BASIC OPERATION

## ■ Display

The display is used as follows.



### Guide mark (white)

- Lights up when the key can be used.

### Digital display / SUB (green)

- Shows the item set using display switching mode. For details, refer to “4-2-1 Display Switching Mode”.
- Shows the setting item.



### Digital display / MAIN (white)

- Shows the judgment value.
- Shows the setting.

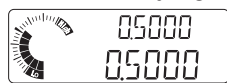

### Circle meter (orange, green)

- Shows the teaching mode and increases / decreases of the judgment range set with the HIGH set value / LOW set value.

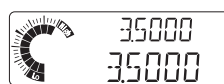
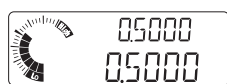
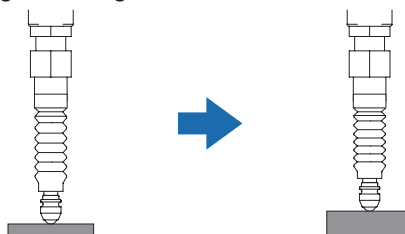

- Shows the count when an operation key is long-pressed for 2 seconds.



- The number of setting items in the level lights up, and the order of the setting times is shown by blinking.

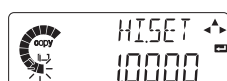



4-2 Explanation of Modes

4-2-1 Display Switching Mode

<Overview>

You can change the display of the digital display / SUB (green) as needed for the task. Using the display switching function, you can display the actual measured value (spindle position) and a judgment value such as a calculation result at the same time for comparison. This makes it easy to check the state of sensor head measurement.

<Settings>

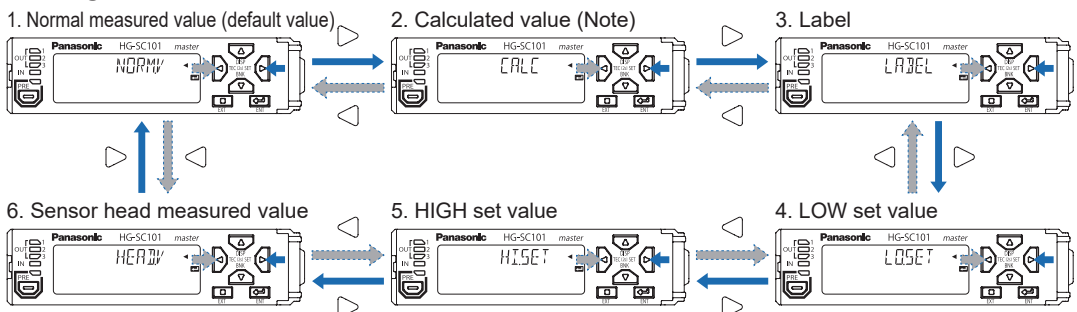

	Name	Digital display SUB (green)	Description	Factory default state
1	Normal measured value	NORM.V	Shows the normal measured value. • When displayed while using the hold function, you can check internal measured values that are not held.	Default state
2	Calculated value (Note)	CALC	Shows the calculated value. • When displayed while using the calculation function and hold function, you can check calculation results that are not held.	—
3	Label	LABEL	You can view and set any values or characters. • This saves you the trouble of attaching sensor number and other labels on the controller.	—
4	LOW set value	LOSET	Shows the LOW set value. • You can check the judgment value and lower limit value at the same time.	—
5	HIGH set value	HISET	Shows the HIGH set value. • You can check the judgment value and upper limit value at the same time.	—
6	Sensor head measured value	HEAD.V	Shows the measured value (spindle position) from the sensor head. • You can display this while using a preset or the calibration function to check the actual pre-correction measured value (spindle position).	—

Note: Calculation function settings are configured on the master unit. When a setting other than "STAND" (standard difference) is selected for the calculation function, "CALC" appears only on the master unit. When the "STAND" (standard difference) setting is selected for the calculation function, "CALC" appears on the slave units but not on the master unit. When the calculation function is not used, this does not appear on either the master unit or the slave units.

<Reference>

- "HEAD.V" (Head Value) is the measured value (spindle position) from the sensor head.
- "NORM. V" (Normal Value) reflects the preset, measurement direction, lever ratio, and calibration function.
- The judgment value that appears in the digital display / MAIN (white) triggers judgment output ON / OFF based on the LOW set value and the HIGH set value. Analog output is also output based on the judgment value.

For the data flow, refer to "5-1-2 Data Flow".

# BASIC OPERATION

## <Setting method>

1. Long-press the UP key for 2 seconds. (The number of lit increments in the circle meter increases.)

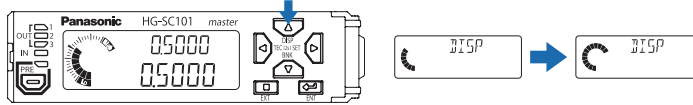

Long-press for 2 seconds

2. "NORM.V" (sensor head measured value) appears in the digital display / SUB (green).

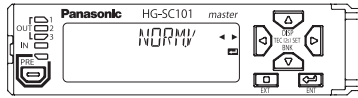

3. Press the LEFT / RIGHT key to change to the item you want to display.

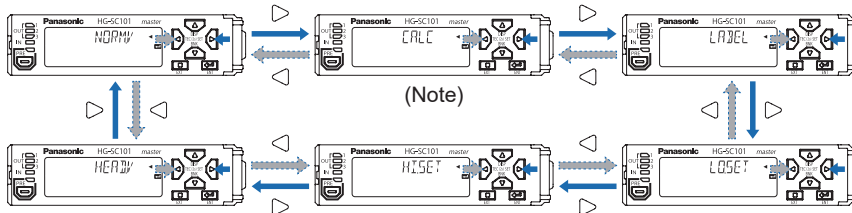

Note: Calculation function settings are configured on the master unit. When a setting other than "STAND" (standard difference) is selected for the calculation function, "CALC" appears only on the master unit. When the "STAND" (standard difference) setting is selected for the calculation function, "CALC" appears on the slave units but not on the master unit. When the calculation function is not used, this does not appear on either the master unit or the slave units.

4. Press the ENTER key to finalize the setting and return to the base screen.

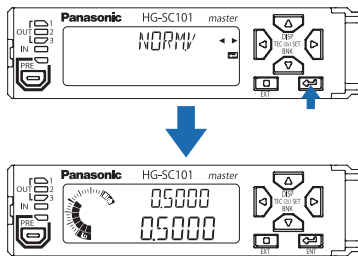

If you press the ENTER key with "LABEL" selected, you will move to the label setting screen.

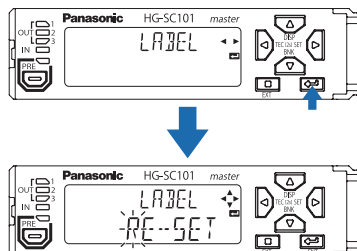

5. Press the UP / DOWN key to change the alphanumeric character. Press the LEFT / RIGHT key to change the digit position.

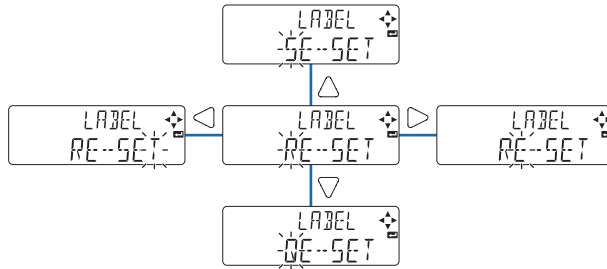

6. Press the ENTER key to finalize the setting and return to the base screen.

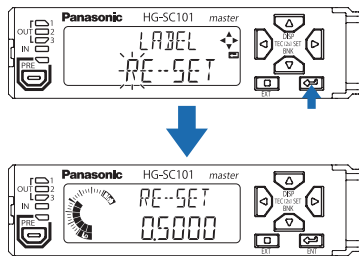

## BASIC OPERATION

### 4-2-2 Presets

#### <Overview>

You can perform zero-point adjustment, and shift to any preset value.

You can perform reference zero-point adjustment when the sensor head has been replaced or when the workpiece is changed, and set the dimensions of the master workpiece as preset values for use as master values (reference values).

#### <Presets>

1. Perform master workpiece measurement.

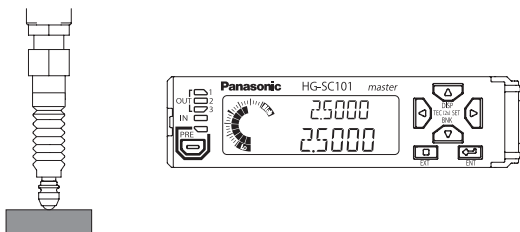

2. Press the preset key in the master workpiece measurement state.  
When the preset function turns ON, the preset indicator (green) lights up.  
If the preset value is set to "0.0000" (default setting), you can perform zero-point adjustment.

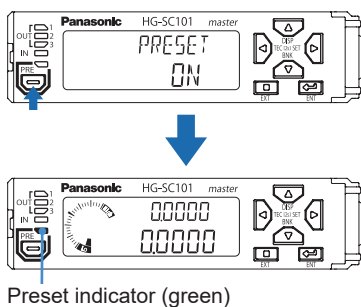

**<Reference>**

- To set preset values, refer to “**5-2-6 Preset Value**”.
- To set preset values by external input, set external input to preset input.
- For preset input by external input, refer to “**5-1-1 Menu Structure**”.
- If you set preset values by key operation, the preset values are saved in internal memory and retained even after the power is turned OFF.
- The usage count is about 1 million.
- If one of the messages in the table below appears in the digital display, the preset has not been executed correctly and an error has occurred.

Digital display		Description
MAIN (white) / SUB (green)	Display	
MAIN (white)	-----	Immediately after the power is turned ON or a re-set is input
MAIN (white)	OVER	When the upper or lower display limit is exceeded
MAIN (white)	ALARM	When an alarm is output
SUB (green)	HWERR	When an error is output

# BASIC OPERATION

---

## <Canceling a preset>

1. To cancel the preset function, long-press the preset key for 2 seconds.

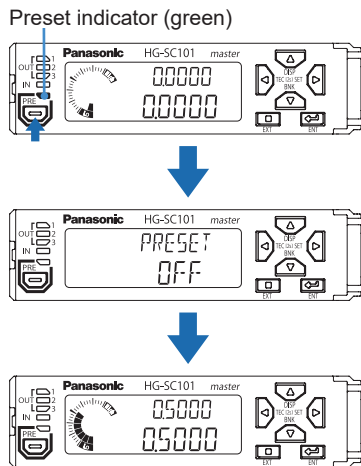

**4-2-3 Teaching Mode**

**<Overview>**

You can automatically set HIGH and LOW set values, and output HIGH / GO / LOW judgment results.

**<Settings>**

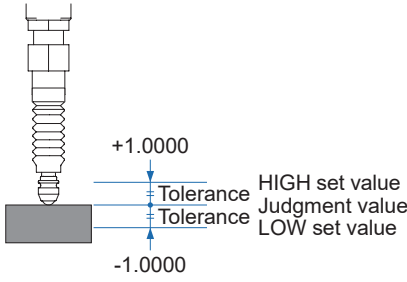
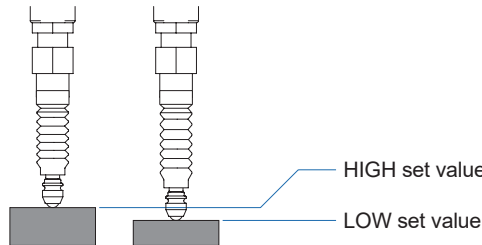
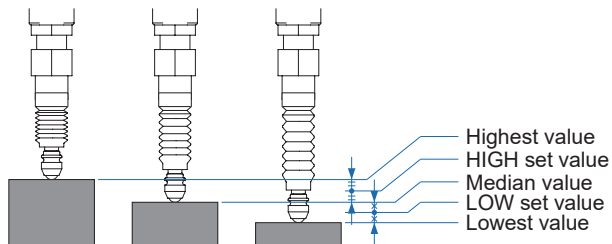
Teaching type	Setting method	Factory default state
<p>1-point teaching</p>	<p>You can use a master workpiece to automatically set upper and lower limit values. Use this method when you want to judge workpieces by a <math>\pm</math> tolerance.</p>  <p>*: When the tolerance (<math>\pm</math>) is set to 1.0000</p>	<p>Default state</p>
<p>2-point teaching</p>	<p>You can use two workpieces to automatically set upper and lower limit values. Use this method when you want to judge workpieces within an upper limit and lower limit range.</p> 	<p>—</p>
<p>3-point teaching</p>	<p>You can use a good workpiece, a HIGH-side defective workpiece, and a LOW-side defective workpiece to automatically set upper and lower limit values. Use this method when you want to judge workpieces within a range that takes the intermediate values between good and defective workpieces as upper and lower limits.</p> 	<p>—</p>

**<Reference>**

To change teaching type, refer to “5-2-4 Teaching Types (TEACH)”.

## BASIC OPERATION

### <1-point teaching>

1. Long-press the LEFT key for 2 seconds. (The number of lit increments in the circle meter increases.)



2. "SET1" appears in the digital display / SUB (green), and the digital display / MAIN (white) blinks.



3. The master workpiece is measured. To acquire the master workpiece judgment value, press the ENTER key.

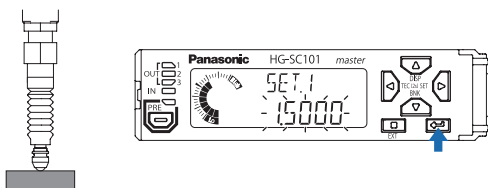

4. When teaching is completed, "GOOD" appears in the digital display / MAIN (white), and the HIGH set value and LOW set value are finalized. You then return automatically to the base screen.

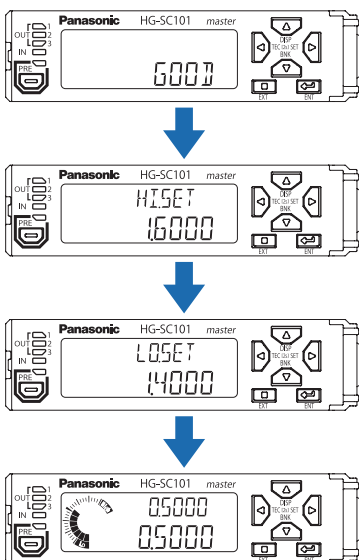



**<Reference>**

- The default setting for the tolerance is "0.1000" ( $\pm 0.1$ ).
- For the tolerance setting, refer to "5-2-5 Tolerance  $\langle \pm \rangle$ ".
- Judgment results that appear in the display are described in the table below.

Digital display / MAIN (white)	Description
GOOD	Stable measurement can be performed
HARD	Stable measurement cannot be performed
ERROR	Teaching did not take place correctly

- If one of the messages in the table below appears in the digital display, teaching did not take place correctly and an error occurred.

Digital display		Description
MAIN (white) / SUB (green)	Display	
MAIN (white)	-----	Immediately after the power is turned ON or a pre-set is input
MAIN (white)	OVER	When the upper or lower display limit is exceeded
MAIN (white)	ALARM	During alarm output
SUB (green)	HWERR	When an error is output

## BASIC OPERATION

### <2-point teaching>

1. Long-press the LEFT key for 2 seconds. (The number of lit increments in the circle meter increases.)



2. "SET.1" appears in the digital display / SUB (green), and the digital display / MAIN (white) blinks.



3. Measure the first workpiece, and press the ENTER key.

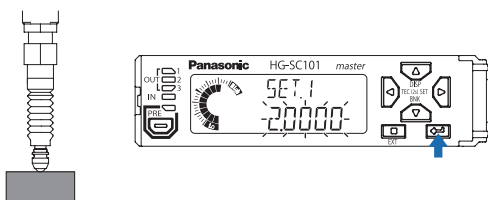

4. "SET.2" appears in the digital display / SUB (green). Measure the second workpiece, and press the ENTER key.

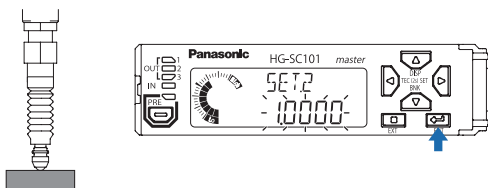

5. When teaching is completed, "GOOD" appears in the digital display / MAIN (white), and the HIGH set value and LOW set value are finalized. You then return automatically to the base screen.

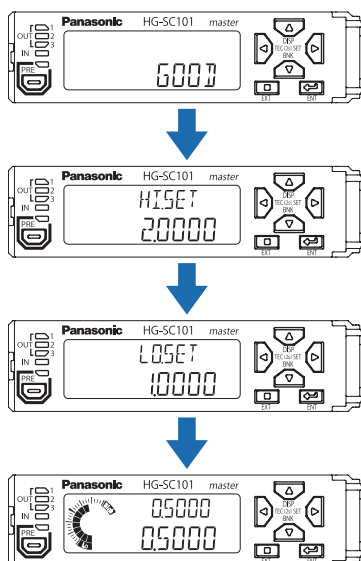

### <Reference>

The higher judgment value is set as the HIGH set value and the lower judgment value is set as the LOW set value, regardless of the order of steps 3 and 4.

## BASIC OPERATION

### <3-point teaching>

1. Long-press the LEFT key for 2 seconds. (The number of lit increments in the circle meter increases.)



2. "SET.1" appears in the digital display / SUB (green), and the digital display / MAIN (white) blinks.



3. Measure the HIGH-side defective workpiece, and press the ENTER key.

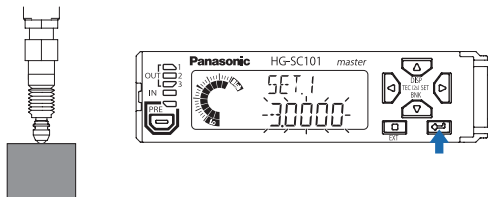

4. "SET.2" appears in the digital display / SUB (green). Measure the good workpiece, and press the ENTER key.



5. "SET.3" appears in the digital display / SUB (green). Measure the LOW-side defective workpiece, and press the ENTER key.

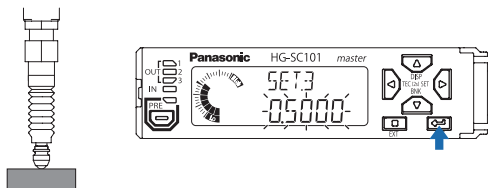

6. When teaching is completed, "GOOD" appears in the digital display / MAIN (white), and the HIGH set value and LOW set value are finalized. You then return automatically to the base screen.

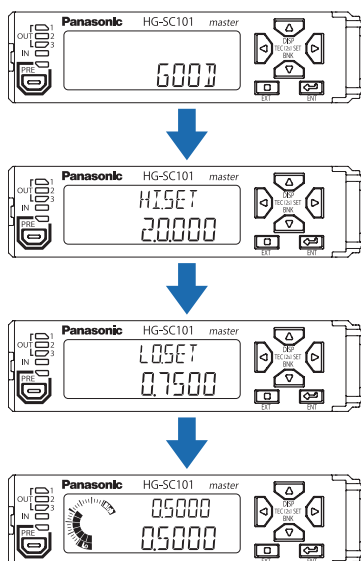

### <Reference>

Regardless of the order of steps 3, 4 and 5, the workpiece judgment values are sorted in order from the highest to the lowest value. The value between the highest value and the median value is set as the HIGH set value, and the value between the lowest value and the median value is set as the LOW set value.

## BASIC OPERATION

### ■ HIGH Set Value Fine Adjustment Function and LOW Set Value Fine Adjustment Function

#### <Overview>

You can fine adjust the HIGH set value and LOW set value as needed.

#### <HIGH set value setting method>

1. Short-press the UP key from the base screen. "HI.SET" appears in the digital display / SUB (green), and the HIGH set value appears in the digital display / MAIN (white).

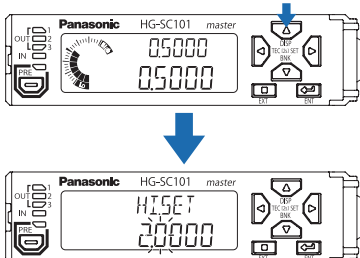

2. Press the LEFT / RIGHT key to change the digit position. Press the UP / DOWN key to increase or decrease the value.

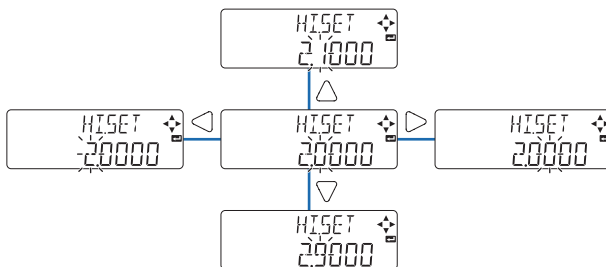

3. Press the ENTER key to finalize the setting.

#### <Reference>

If you take no action for 5 seconds, the screen will automatically return to the base screen and the setting will be finalized.

## <LOW set value setting method>

1. Short-press the DOWN key from the base screen. "LO.SET" appears in the digital display / SUB (green), and the LOW set value appears in the digital display / MAIN (white).

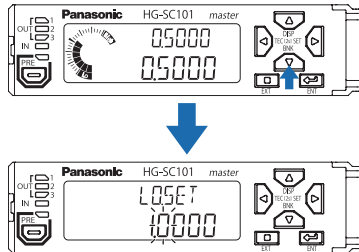

2. Press the LEFT / RIGHT key to change the digit position. Press the UP / DOWN key to increase or decrease the value.

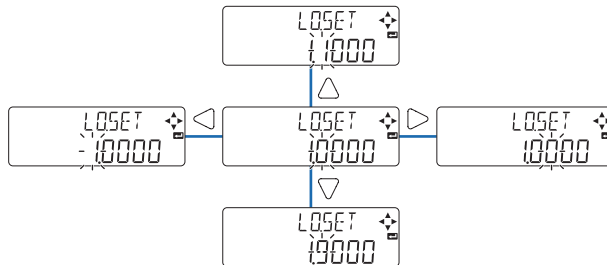

3. Press the ENTER key to finalize the setting.

### <Reference>

If you take no action for 5 seconds, the screen will automatically return to the base screen and the setting will be finalized.

## BASIC OPERATION

### 4-2-4 Bank Mode

#### <Overview>

You can save / load the HIGH set value or LOW set value to/from a specified bank (1 to 3). You can use the bank function to save settings for an object to be measured in a bank, and easily load the settings when needed.

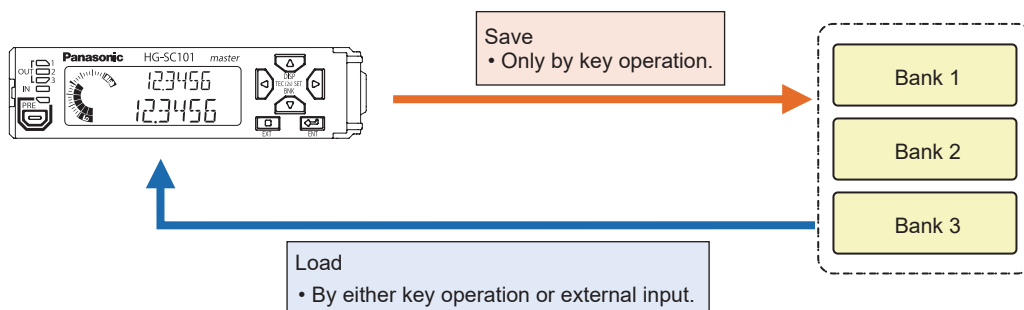

#### ■ Setting Items Saved to and Loaded from Banks

Setting item	Factory default state
All setting items	–
HIGH set value, LOW set value	Default state
HIGH set value, LOW set value, preset value	–

#### <Reference>

- Setting items saved to and loaded from banks can be changed in setting mode. For the setting procedure, refer to “**5-6 Bank Settings**”.
- Set values saved to and loaded from banks are saved in internal memory and retained even after the power is turned OFF.
- The usage count is about 1 million.

#### ■ How to Save and Load Settings to / from a Bank

As shown below, there are two methods for saving and loading settings to / from a bank.

Method	Description
Key operation	Save to bank
	Load from bank
External input	Load from bank



## ■ Saving and Loading by Operation Key

### <Setting method>

1. Long-press the DOWN key for 2 seconds. (The number of lit increments in the circle meter increases.)

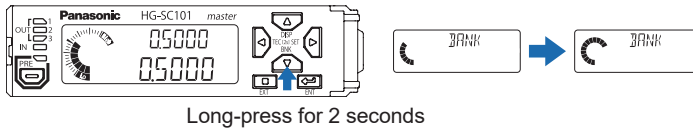

2. "SAVE" appears in the digital display / SUB (green).

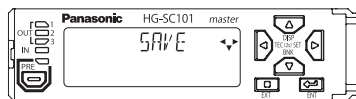

3. Press the LEFT / RIGHT key to switch between "SAVE" and "LOAD".



4. Press the DOWN key. "BANK1" appears in the digital display / SUB (green), and "YES" appears in the digital display / MAIN (white).

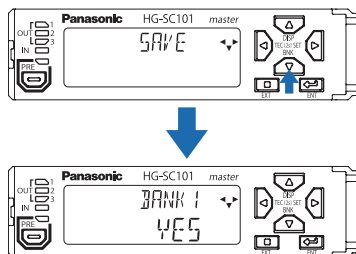

5. Press the LEFT / RIGHT key to change banks.



## BASIC OPERATION

6. Press the ENTER key to set the bank. "YES" blinks in the digital display / MAIN (white).

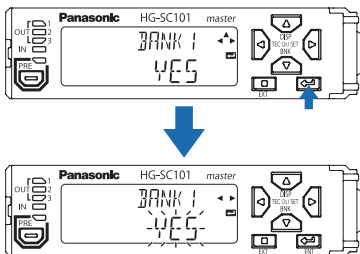

7. Press the LEFT / RIGHT key to switch between "YES" and "NO" .

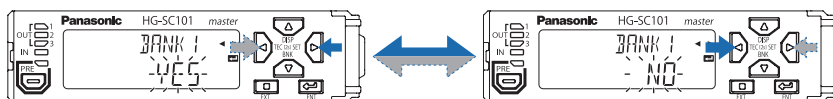

8. Press the ENTER key.  
If you selected "SAVE" in step 3, the current settings are saved to the bank.  
If you selected "LOAD" in step 3, the settings saved in the bank are loaded.

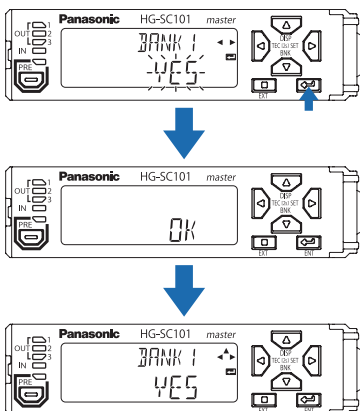

9. Press the EXIT key twice to return to the base screen.

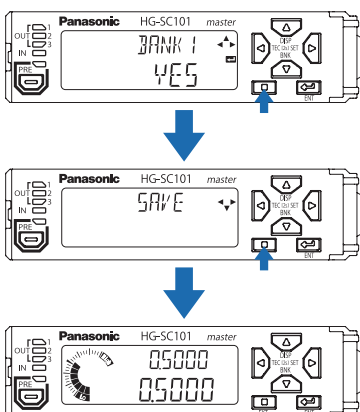

### ■ Loading by External Input

By setting external input to bank A input or bank B input, you can load settings saved in a bank by external input.

Using combinations of bank A input and bank B input ON / OFF, you can load settings from each bank.

- Input bank input 20ms or more.
- Bank A input and bank B input combinations are shown below.

Bank No.	Bank A	Bank B
Bank 1	ON	OFF
Bank 2	OFF	ON
Bank 3	ON	ON

#### <Reference>

For the procedure for setting external input to bank A input or bank B input, refer to “5-3-3 External Input”.

## BASIC OPERATION

### 4-2-5 Key Lock

#### <Overview>

You can prevent accidental key operation during measurement.

While key lock is activated, operation of all keys except the key lock release key is prohibited.

#### <Key lock setting>

1. Simultaneously long-press the ENTER key and EXIT key for 3 seconds. (The number of lit increments in the circle meter increases.)

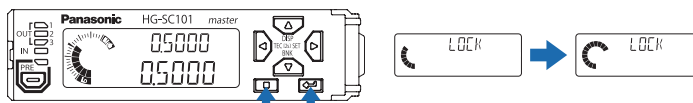

Simultaneously long-press for 3 seconds

2. "LOCK" appears in the digital display / SUB (green), and "ON" appears in the digital display / MAIN (white). You then return automatically to the base screen.



#### <Reference>

- When any key is pressed, "LOCK" appears in the digital display / SUB (green), and "ACT" appears in the digital display / MAIN (white).



- Functions that use external input are enabled.

### <Key lock release>

1. Simultaneously hold down the ENTER key and EXIT key. The digital display / SUB (green) and the digital display / MAIN (white) change as shown below. When "OFF" appears in the digital display / MAIN (white), release the keys.

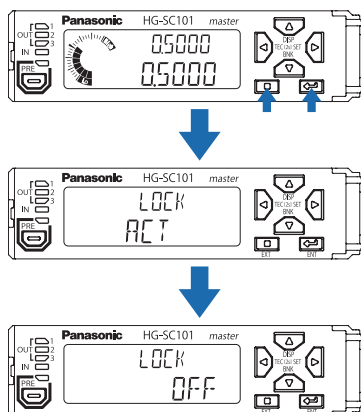

(MEMO)

# Chapter 5 FUNCTION SETTINGS

5-1 Overview of Setting Menu	5-4
5-1-1 Menu Structure	5-4
5-1-2 Data Flow	5-6
5-1-3 Setting Items and Default Values	5-7
5-2 Basic Settings (BASIC)	5-10
5-2-1 HIGH Set Value (HISET)	5-11
5-2-2 LOW Set Value (LOSET)	5-12
5-2-3 Hysteresis (HYSTER)	5-13
5-2-4 Teaching Types (TEACH)	5-15
5-2-5 Tolerance <±> (TOL (±))	5-17
5-2-6 Preset Value (PRVAL)	5-18
5-2-7 Preset Data Selection (PROBJ)	5-19
5-2-8 Preset Save (PRSAVE)	5-20
5-2-9 Measurement Direction (DIRECT)	5-21
5-2-10 Lever Ratio (LEVER)	5-23
5-2-11 Response Time (SPEED)	5-24
5-2-12 Output Operation (OUTPUT)	5-26
5-3 Advanced Settings (ADVANCE)	5-27
5-3-1 Hold Setting (HOLD)	5-28
5-3-2 Input All (ALL IN) (Master Unit Only)	5-47
5-3-3 External Input (EXTIN)	5-49
5-3-4 External Output (EXTOUT)	5-51
5-3-5 Number of Digits Displayed (DIGIT)	5-54
5-3-6 Analog Scaling (ANALOG)	5-55
5-3-7 Scaling Upper Limit Value / Scaling Lower Limit Value (ANALHI / ANALLO)	5-57
5-3-8 Eco Mode (ECO)	5-60
5-3-9 Alarm Setting (ALARM)	5-61

5-4 Calculation Settings (〔CALC〕 (Master Unit Only) .....	5-70
5-4-1 Calculation Mode (MODE) .....	5-71
5-4-2 Calculation Application Selection (APPLI) .....	5-72
5-5 Copy Settings (〔COPY〕) .....	5-79
5-5-1 Copy select individual (〔PYSEL〕 (Master Unit Only) .....	5-81
5-5-2 Copy Select All (〔HKAALL〕 (Master Unit Only) .....	5-83
5-5-3 Copy Execution (〔PYEXEC〕 (Master Unit Only) .....	5-84
5-5-4 Copy Lock (〔LOCK〕 (Slave Units Only) .....	5-85
5-6 Bank Settings (〔BANK〕) .....	5-86
5-6-1 Bank Save Setting (〔BANKSAT〕) .....	5-86
5-7 Calibration Settings (〔CALIB〕) .....	5-88
5-7-1 Calibration Selection (〔CALSEL〕) .....	5-88
5-8 Initialization (〔RESET〕) .....	5-92
5-9 Maintenance (〔MAINTEN〕) .....	5-94



(MEMO)

# FUNCTION SETTINGS

## 5-1 Overview of Setting Menu

### 5-1-1 Menu Structure

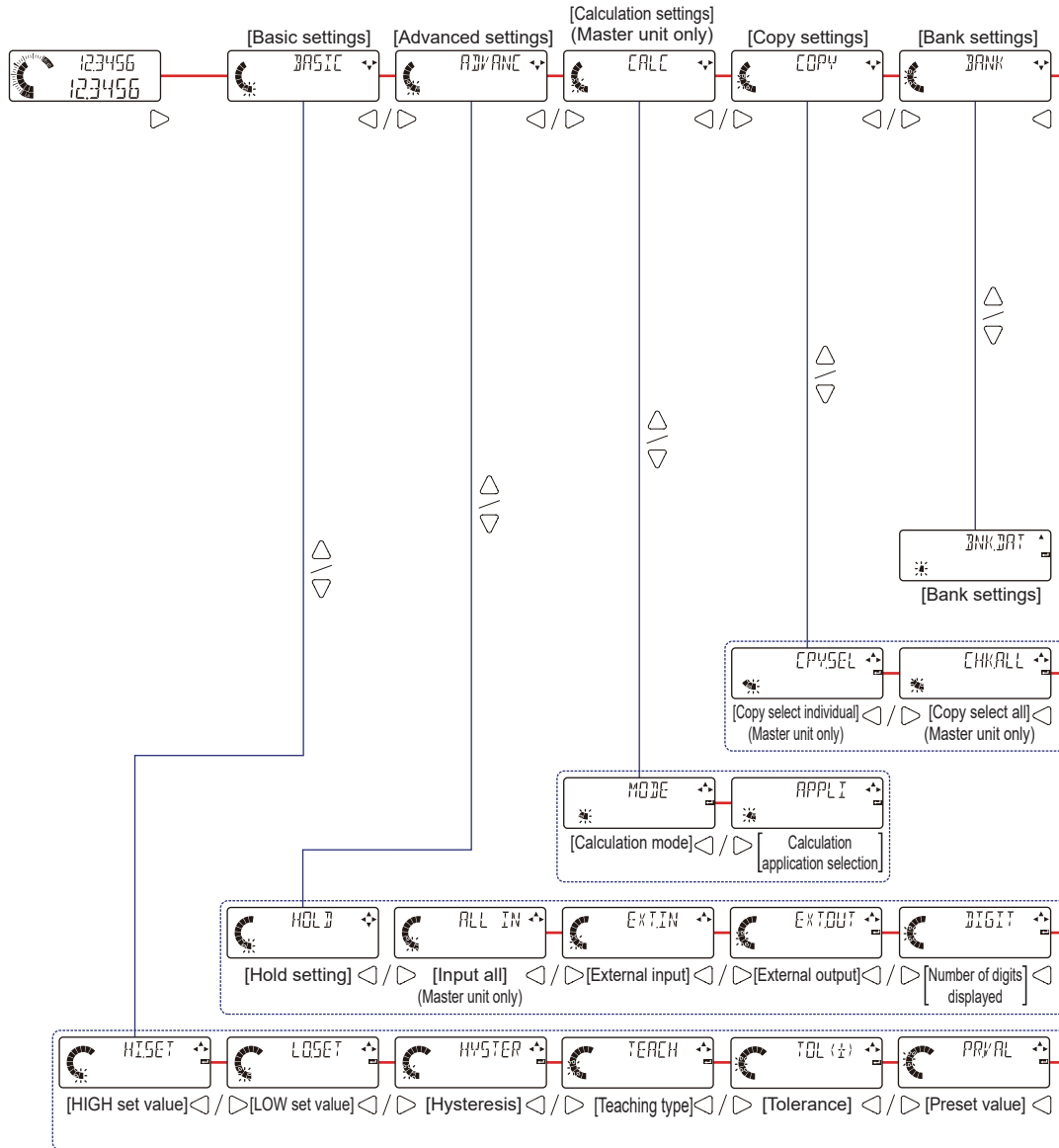

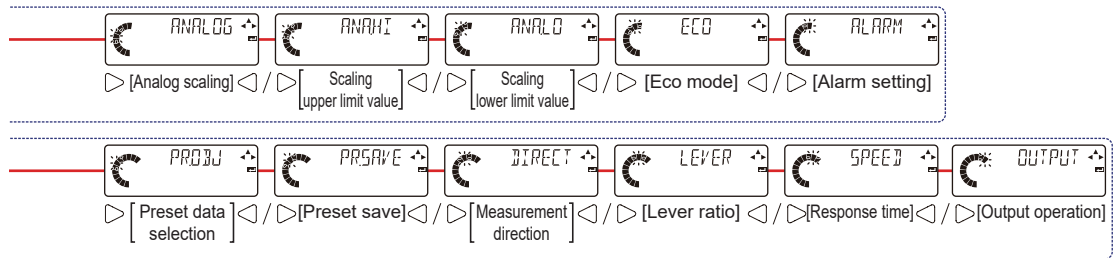
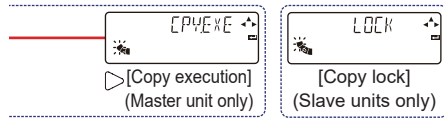
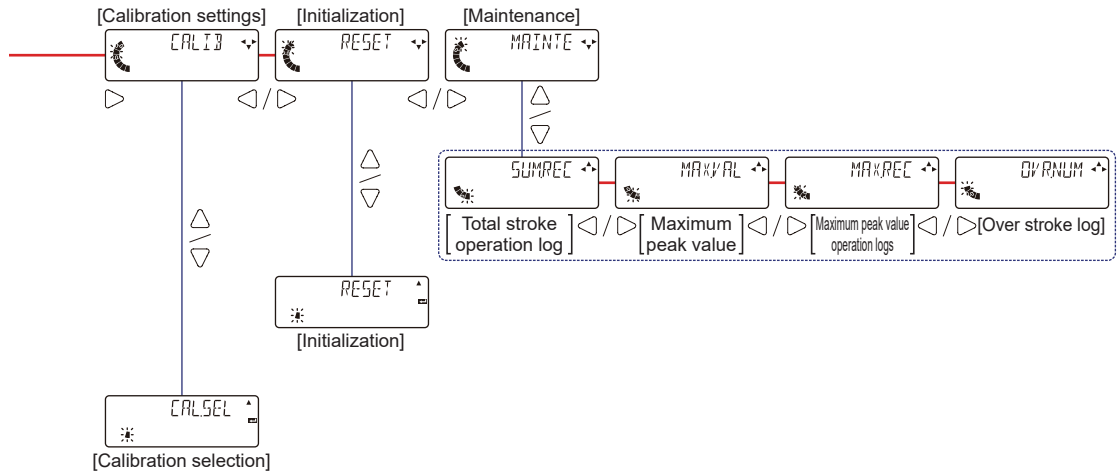

# FUNCTION SETTINGS

## 5-1-2 Data Flow

For the controllers, up to 15 slave units can be connected per master unit. (When communication unit consolidated: up to 14 slave units)

Each can perform independent measurements, as well as calculations on measurement values among controllers.

Functions are executed as indicated in the flow below.

Example: Simultaneous use of the "THICK" (thickness measurement) calculation application selection and independent measurement when one master unit and two slave units are connected

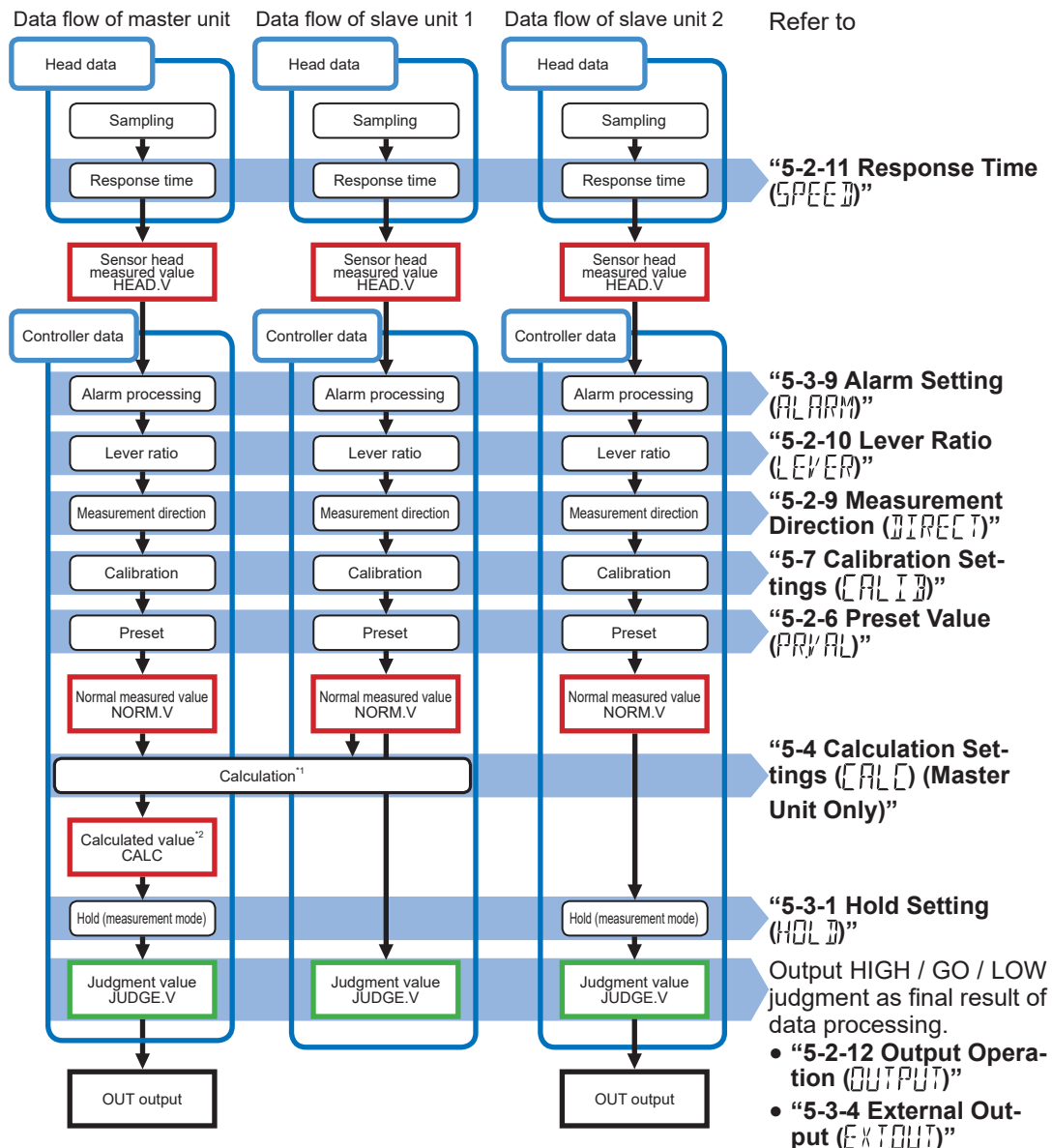

\*1 When a calculation mode is selected: The number of slave units used in the calculation varies depending on the calculation application selection.

\*2 Only appears during calculation.

## 5-1-3 Setting Items and Default Values

Setting item	Setting range / set values	Page
Basic settings (BASIC)	HIGH set value (HI.SET) You can manually set any HIGH set value (upper limit value) -199.9999 to 199.9999 (mm) <Default value: 5.0000>	5-11
	LOW set value (LO.SET) You can manually set any LOW set value (lower limit value) -199.9999 to 199.9999 (mm) <Default value: 1.0000>	5-12
	Hysteresis (HYSTER) If the judgment value (JUDGE.V) fluctuates near the HIGH or LOW set value, the judgment output may repeat ON / OFF and operation may become unstable. Operation can be stabilized by increasing the hysteresis value. 0.0000 to 199.9999 (mm) <Default value: 0.0030>	5-13
	Teaching type (TEACH) You can set the HIGH set value and LOW set value automatically. TCH.1 (1-point teaching) / TCH.2 (2-point teaching) / TCH.3 (3-point teaching) <Default value: TCH.1>	5-15
	Tolerance <±> (TOL<±>) When performing 1-point teaching, you can set a value equal to the master workpiece judgment value (JUDGE.V) plus a tolerance as the HIGH set value, and a value equal to the master workpiece judgment value minus a tolerance as the LOW set value. <Default value: 0.1000>	5-17
	Preset value (PR. VAL) When performing preset, you can shift (add or subtract) to any preset value. -199.9999 to 199.9999 (mm) <Default value: 0.0000>	5-18
	Preset data selection (PR.OBJ) When using a preset, you can select the data (NORM.V or JUDGE.V). NORM.V (normal measured value) / JUDGE.V (judgment value) <Default value: NORM.V>	5-19
	Preset save (PR.SAVE) You can write preset information to EEPROM by setting preset save to ON. The preset ON / OFF state and offset values are saved even when the power is turned OFF. OFF (preset save OFF) / ON (preset save ON) <Default value: OFF>	5-20
	Measurement direction (DIRECT) You can set whether the normal measured value (NORM.V) and judgment value (JUDGE.V) are displayed normally (plus direction) or in reverse (minus direction) when the sensor head spindle is pressed in. NORMAL (normal) / REVERS (reverse) <Default value: NORMAL>	5-21
	Lever ratio (LEVER) When using a lever for measurement, you can display the measured value multiplied by the lever ratio as the judgment value (JUDGE.V). 0.1 to 100.0 <Default value: 1.0>	5-23
	Response time (SPEED) You can set the time until the judgment value (JUDGE.V) is finalized (response time) when the sensor head starts measurement. 3 (3ms) / 5 (5ms) / 10 (10ms) / 100 (100ms) 500 (500ms) / 1000 (1,000ms) <Default value: 100>	5-24
	Output operation (OUTPUT) You can select the judgment output operation. N.O. (normal open) / N.C. (normal closed) <Default value: N.O.>	5-26

## FUNCTION SETTINGS

Setting item		Setting range / set values	Page
Advanced settings (ADVANC)	Hold setting (HOLD)	Measurement mode (MEAS) You can select the hold mode. S-H (sample hold) / P-H (peak hold) / B-H (bottom hold) / P-P (peak to peak hold) / P-P/2 (peak to peak hold / 2) / NG-H (NG hold) / SLF.S-H (self sample hold) / SLF.P-H (self peak hold) / SLF.B-H (self bottom hold) <Default value: S-H>	5-28
		Trigger mode (TRG) You can select the external trigger input action. HOLD (hold) / 1 SHOT (one-shot) <Default value: HOLD>	5-29
		Self trigger level (SLF.LV) You can use the self (internal) trigger to set the criterion level for use of the hold function. -199.9999 to 199.9999 <Default value: 0.500>	5-37
		Self trigger edge direction (SLF.EDG) You can use the self trigger level to set the edge direction used to measure the hold value. UP (rise) / DOWN (fall) <Default value: UP>	5-37
		Self trigger delay (SLF.DLY) When using the self sampling hold function, you can set the self trigger delay type. DLY.WD (static width) / DLY.TIM (delay time) <Default value: DLY.WD>	5-37
		Static width (DLY.WD) You can set the fluctuation width for stabilization that triggers the start of hold. 0 to 199.9999 (mm) <Default value: 0.0100>	
		Delay timer (DLY.TIM) You can set a delay time for the start of hold. 0 to 9999 (mm) <Default value: 1000>	
	Input all (ALL IN) (Master unit only) You can enable ALL IN on the master unit to input trigger input, preset input, and other signals into all connected slave units. ONE (single) / ALL (all) <Default value: ONE>	5-47	
	External input (EXT.IN) You can select from four combinations for the signals that are input into input 1 / input 2 / input 3 of external input. P/R/T (preset / reset / trigger) / BANK/P (bank A, B / preset) / BANK/R (bank A, B / reset) / BANK/T (bank A, B / trigger) <Default value: P/R/T>	5-49	
	External output (EXT.OUT) You can select from four combinations for the signals that are output into output 1 / output 2 / output 3 of external output. 3 VAL (HI, GO, LO) / 2 VAL (HI or LO, INRANGE, ALARM) / LOGIC (LOGIC, ALARM) / LOGIC2 <Default value: 3 VAL>	5-51	
	Number of digits displayed (DIGIT) You can change the number of digits that appear after the decimal point of the digital display. 0.1 / 0.01 / 0.001 / 0.0001 <Default value: 0.0001>	5-54	
	Analog scaling (ANALOG) When the judgment value (JUDGE.V) is converted to a current (4 to 20mA) and output as analog output, you can set the upper limit value and lower limit value. DEFAULT (default) / FREE (free) <Default value: DEFAULT>	5-55	
	Scaling upper limit value (ANA.HI) When analog scaling is set to "FREE", you can set the upper limit value of scaling. -199.9999 to 199.9999 (mm) <Default value: 10.0000>	5-57	
	Scaling lower limit value (ANA.LO) When analog scaling is set to "FREE", you can set the lower limit value of scaling. -199.9999 to 199.9999 (mm) <Default value: 0.0000>		
Eco mode (ECO) You can save power by having the backlight of the controller display turn OFF when idle. OFF (Eco OFF) / ON (Eco ON) <Default value: OFF>	5-60		

Setting item		Setting range / set values	Page
Advanced settings (ADVANC)	Alarm setting (ALARM)	Alarm delay count (DELAY) You can set the delay count until an alarm is output. 1 to 1000 <Default value: 1000>	5-62
		Pressure check (PRS.CHK) You can turn the pressure check ON / OFF. ON (check ON) / OFF (check OFF) <Regular type default value: ON> <Air-driven type default value: OFF>	5-62
		Pressure check set value (PRS.SET) When the pressure check is set to ON, you can set the pressure check set value. -199.9999 to 199.9999 (mm) <Regular 10 mm type, air-driven type default value: 10.0000> <Regular 32 mm type default value: 32.0000>	
		Catch check (CAT.CHK) You can turn the catch check ON / OFF. OFF (check OFF) / ON (check ON) <Default value: OFF>	5-66
		Number of connected controllers check (CON.CHK) (Master unit only) When controllers are connected to the master unit, you can check if the number connected has changed when the power is turned ON. OFF (check OFF) / ON (check ON) <Default value: OFF>	5-69
Calculation settings (CALC) (Master unit only)	Calculation mode (MODE) You can perform calculation processing based on the measured values of each of the connected controllers and display the judgment result on the master unit's display or output the judgment result from the master unit. NO.CALC (no calculation) / CALC (calculate) <Default value: NO.CALC>	5-70	
	Calculation application selection (APPLI) When calculation mode is set to "CALC", you can select the application that is used for calculation. MAX (maximum value) / MIN (minimum value) / FLAT (flatness) / AVERAG (average value) / STAND (standard difference) / TORSIN (torsion) / CURVEA (curvature) / THICK (thickness) <Default value: MAX>	5-72	
Copy settings (COPY)	Copy select individual (CPY.SEL) (Master unit only) You can select individual items to be copied.	5-81	
	Copy select all (CHK.ALL) (Master unit only) You can select all items for copying. YES / NO <Default value: YES>	5-83	
	Copy execution (CPY.EXE) (Master unit only) You can execute copying of individually selected settings or all settings from the master unit to the slave units. YES / NO <Default value: YES>	5-84	
	Copy lock (LOCK) (Slave unit only) You can prohibit copying from the master unit. OFF (lock OFF) / ON (lock ON) <Default value: OFF>	5-85	
Bank settings (BANK)	Bank save selection (BNK.DAT) You can select the settings in a bank that are read by a bank read. THRS (HIGH set value, LOW set value) / THRS.PR (HIGH set value, LOW set value, preset value) / ALL (all) <Default value: THRS>	5-86	
Calibration settings (CALIB)	Calibration selection (CAL.SEL) You can perform zero-point adjustment and span adjustment when a sensor head is replaced to reduce installation error. DEFAULT (default) / USER (user settings) <Default value: DEFAULT>	5-88	
	During user settings Acquired value 1 (CL.SET1) Move the spindle to the zero point for calibration and acquire the measured value.		
	Acquired value 2 (CL.SET2) Move the spindle to the target point for span adjustment and acquire the measured value.		
	Adjustment value 2 (AJ.VAL2) Enter a number for the target value. -199.9999 to 199.9999 (mm) <Default value: 10.000>		
Initialization (RESET)	Initialization (RESET) You can return the controller settings to the factory default state. The pressure check set value changes according to the type of sensor head connected. YES / NO	5-92	
Maintenance (MAINTE)	Total stroke operation log (SUM.REC)	You can display the sensor head operation log and other information.	
	Maximum peak value (MAX.VAL)		
	Maximum peak value operation log (MAX.REC)		
	Over stroke log (OVR.NUM)		

# FUNCTION SETTINGS

## 5-2 Basic Settings (BASIC)

### • Structure of basic settings menu

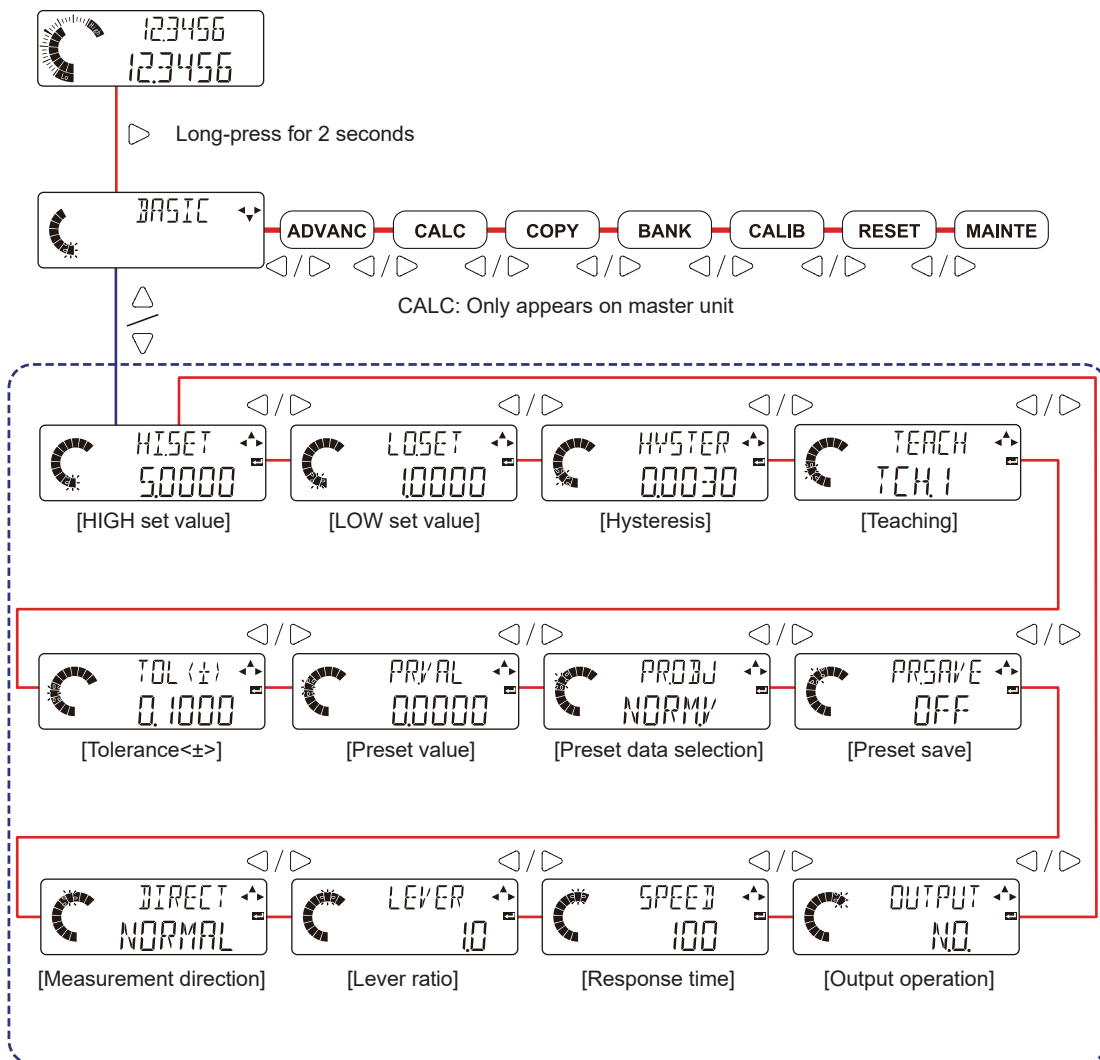



## 5-2-1 HIGH Set Value (HI.SET)

You can manually set any HIGH set value (upper limit value).  
If the judgment value (JUDGE.V) is over the set HIGH set value, a HIGH judgment is output.

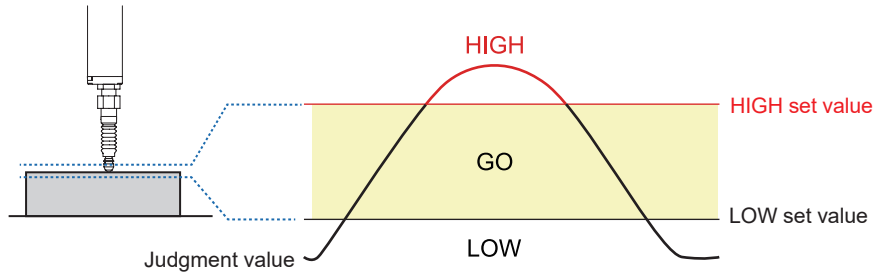

### <Reference>

- Always set a HIGH set value that is higher than the LOW set value.
- You can have the HIGH set value always appear in the digital display / SUB (green).  
For details, refer to “4-2-1 Display Switching Mode”.
- You can set the HIGH set value and LOW set value by teaching.  
For details, refer to “4-2-3 Teaching Mode”.

### Setting method

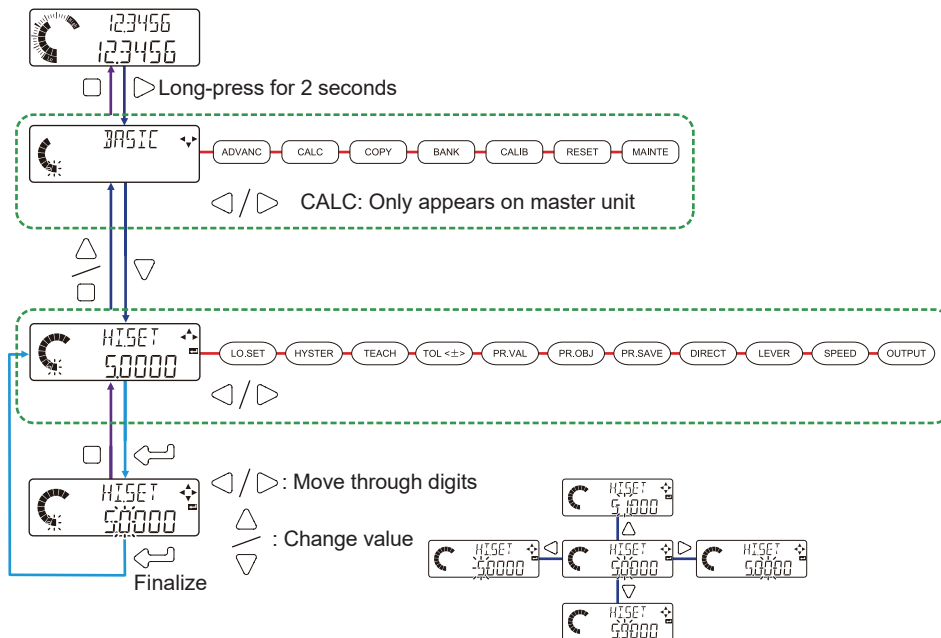

Setting item	Setting range	Default value
HIGH set value (HI.SET)	-199.9999 to 199.9999 (mm)	5.0000

# FUNCTION SETTINGS

## 5-2-2 LOW Set Value (LOSET)

You can manually set any LOW set value (lower limit value).  
 If the judgment value (JUDGE.V) is under the LOW set value, a LOW judgment is output.

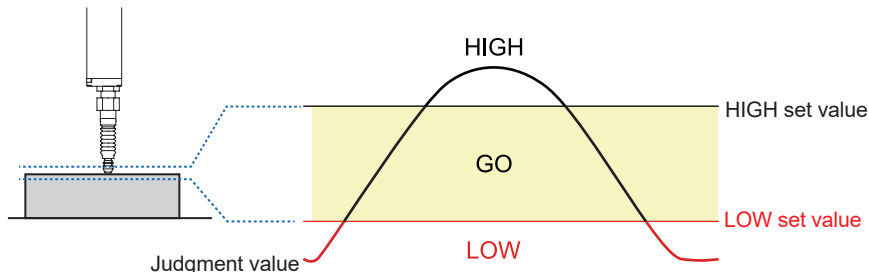

### <Reference>

- Always set a LOW set value that is lower than the HIGH set value.
- You can have the LOW set value always appear in the digital display / SUB (green).  
 For details, refer to “4-2-1 Display Switching Mode”.
- You can set the HIGH set value and LOW set value by teaching.  
 For details, refer to “4-2-3 Teaching Mode”.

### Setting method

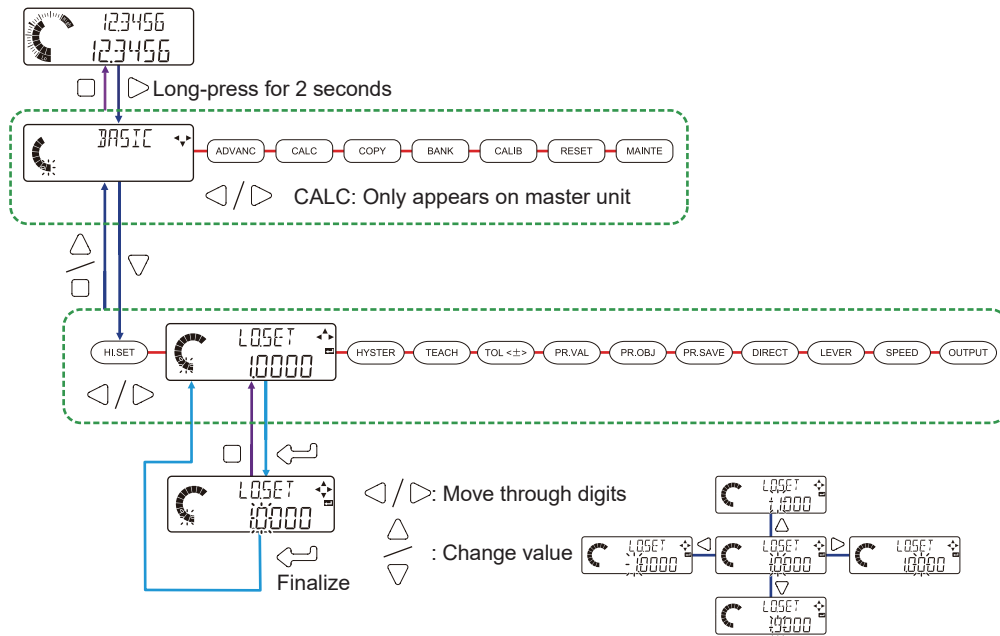

Setting item	Setting range	Default value
LOW set value (LO.SET)	-199.9999 to 199.9999 (mm)	1.0000

**5-2-3 Hysteresis (HYSTER)**

If the judgment value fluctuates near the HIGH or LOW set value, the judgment output may repeat ON / OFF and operation may become unstable. Operation can be stabilized by increasing the hysteresis value.

• **When the hysteresis is "0"**

Fluctuation of the judgment value (JUDGE.V) near the HIGH set value (or LOW set value) will cause the judgment output to become unstable.

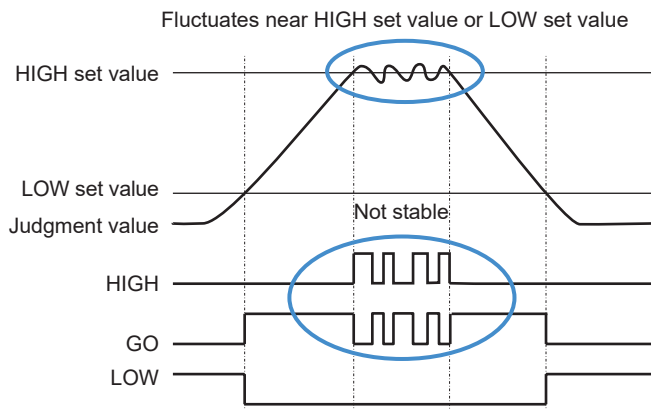

• **When a hysteresis is set**

By setting a hysteresis, the judgment output will remain stable even if the judgment value (JUDGE.V) fluctuates near the HIGH set value (or LOW set value).

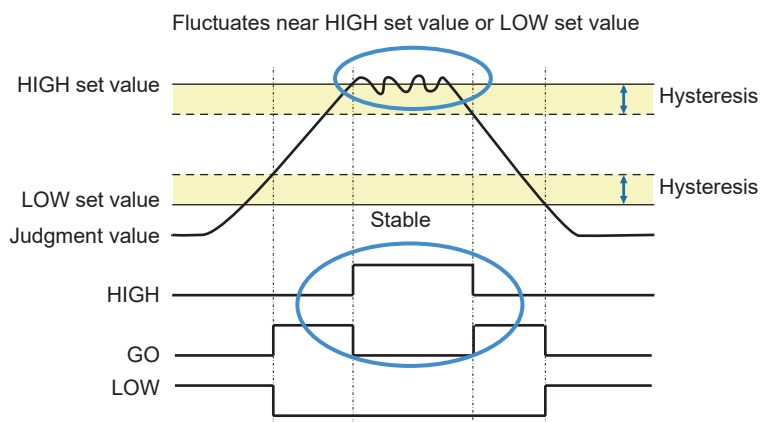

# FUNCTION SETTINGS

## <Reference>

- Set the hysteresis to a value that is smaller than the difference between the HIGH set value and the LOW set value. If the hysteresis is set to a value that is larger than the difference between the HIGH set value and the LOW set value, a GO judgment will not be output.

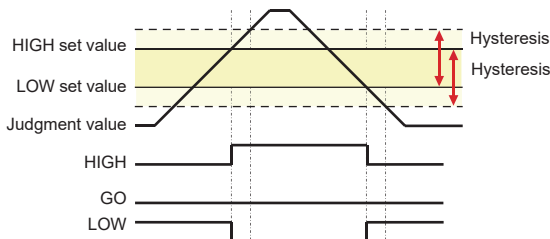

- Even when a hysteresis is set, always set a HIGH set value that is higher than the LOW set value. If the LOW set value is higher than the HIGH set value, a GO judgment will not be output.

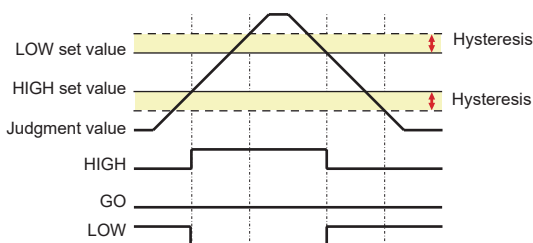

## Setting method

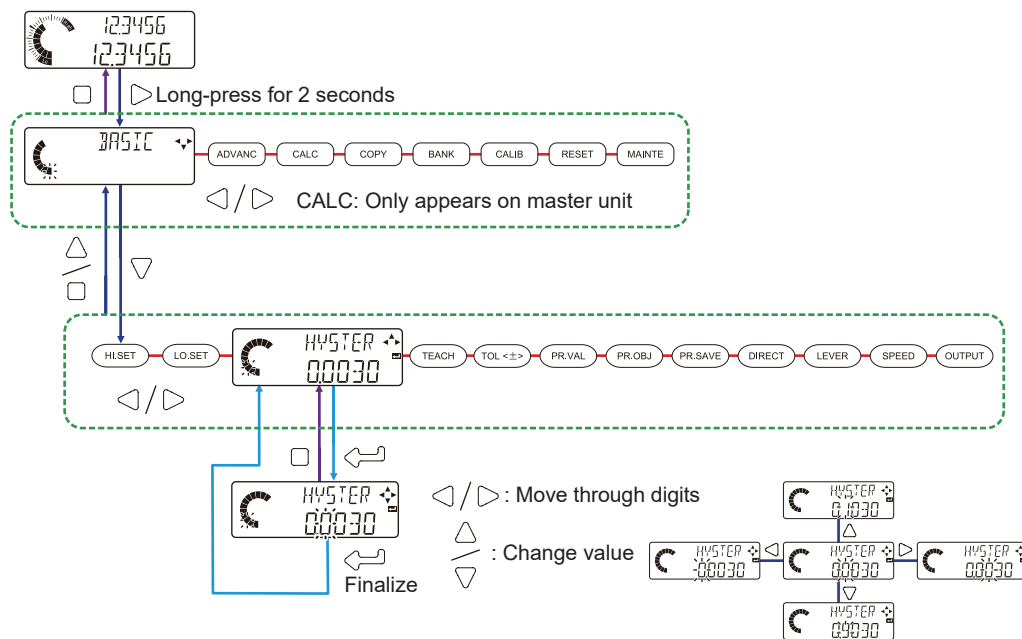

Setting item	Setting range	Default value
Hysteresis (HYSTER)	0 to 199.9999 (mm)	0.0030

## 5-2-4 Teaching Types (TEACH)

You can set the HIGH set value and LOW set value automatically.  
For the teaching method, you can select from "1-point teaching", "2-point teaching", or "3-point teaching".

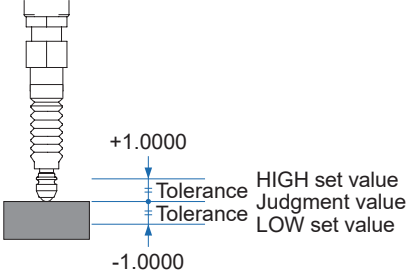
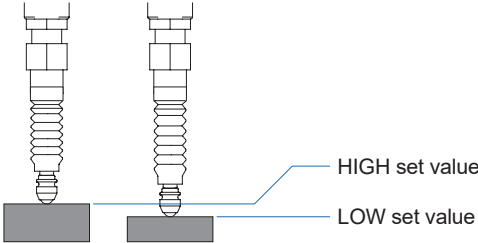
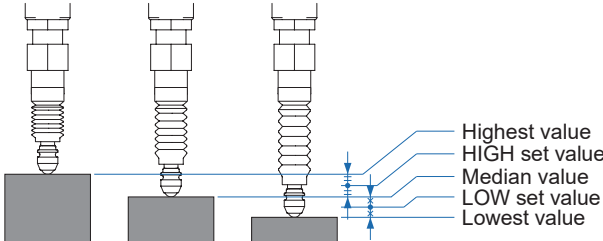
Teaching type	Function	Factory default state
1-point teaching	<p>You can use a master workpiece to automatically set upper and lower limit values. Use this method when you want to judge workpieces by a <math>\pm</math> tolerance.</p>  <p style="text-align: center;">*: When the tolerance (<math>\pm</math>) is set to 1.0000</p>	Default state
2-point teaching	<p>You can use two workpieces to automatically set upper and lower limit values. Use this method when you want to judge workpieces within an upper limit and lower limit range.</p> 	—
3-point teaching	<p>You can use a good workpiece, a HIGH-side defective workpiece, and a LOW-side defective workpiece to automatically set upper and lower limit values. Use this method when you want to judge workpieces within a range that takes the intermediate values between good and defective workpieces as upper and lower limits.</p> 	—

### <Reference>

For teaching type, refer to "4-2-3 Teaching Mode".

# FUNCTION SETTINGS

## Setting method

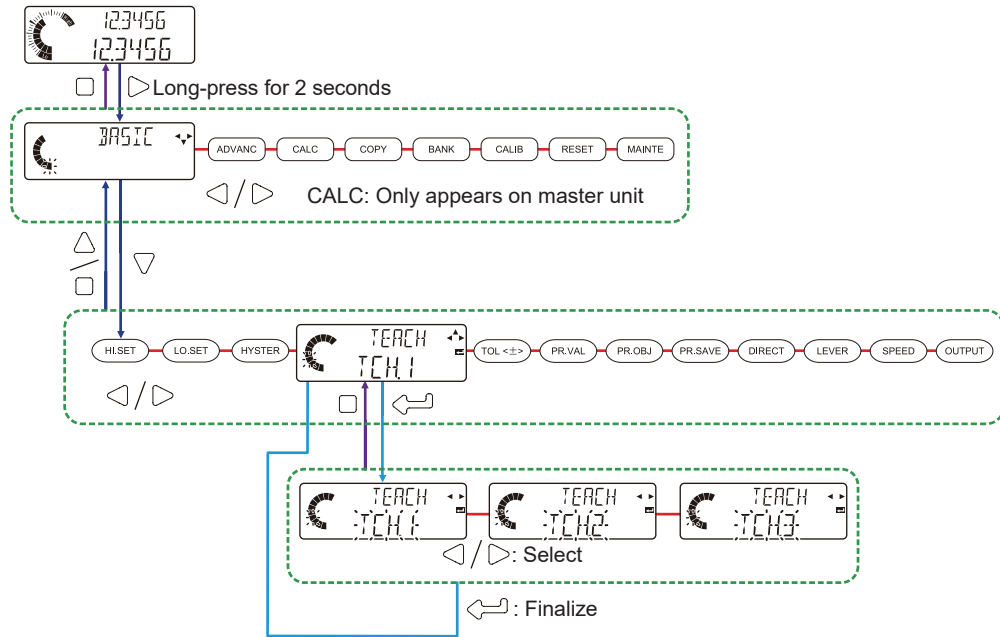

Setting item	Set values	Default value
Teaching type (TEACH)	1-point teaching (TCH.1) 2-point teaching (TCH.2) 3-point teaching (TCH.3)	TCH.1

## 5-2-5 Tolerance <±> (TOL <±>)

When performing 1-point teaching, you can set a value equal to the master workpiece judgment value (JUDGE.V) plus a tolerance as the HIGH set value, and a value equal to the master workpiece judgment value minus a tolerance as the LOW set value.

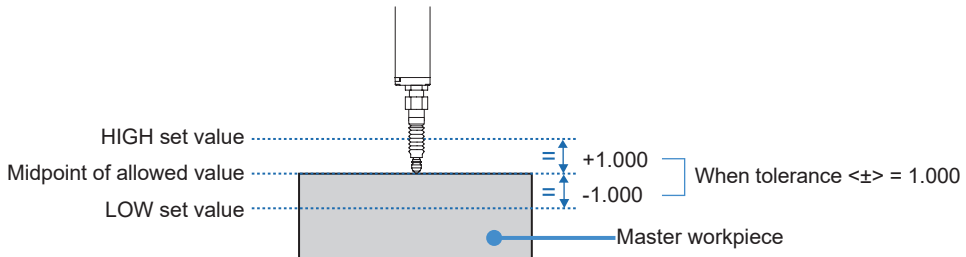

### <Reference>

- The tolerance setting (±) is only valid when 1-point teaching is ON.
- For the 1-point teaching method, refer to “4-2-3 Teaching Mode”.

### Setting method

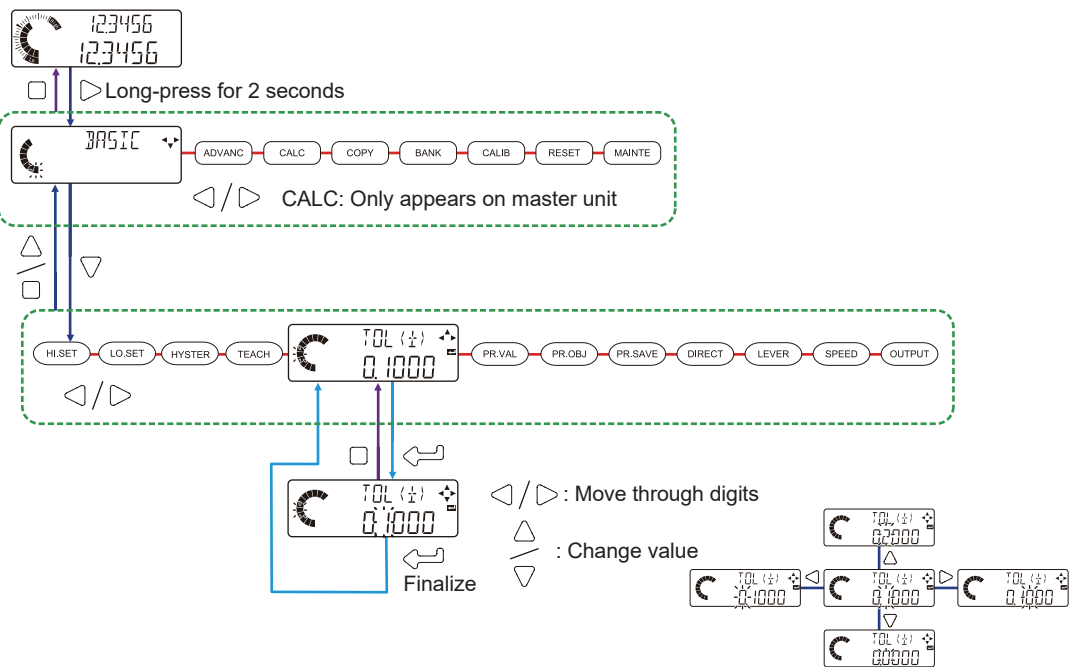

Setting	Setting range	Default value
Tolerance (±) (TOL<±>)	0 to 199.9999	0.1000

# FUNCTION SETTINGS

## 5-2-6 Preset Value (PRVAL)

When performing preset, you can shift (add or subtract) to any preset value. You can set the dimension of a master workpiece as a preset value and use this as a master value (reference value).

- When the preset value is set to "6.0000"

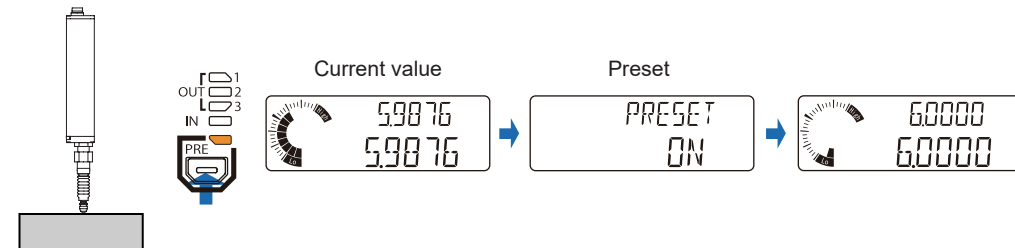

### <Reference>

- If preset is turned ON when the preset value is "0", zero-point adjustment will take place.
- A preset value setting change will be applied even if the preset has been executed.
- For details, refer to "4-2-2 Presets".

### Setting method

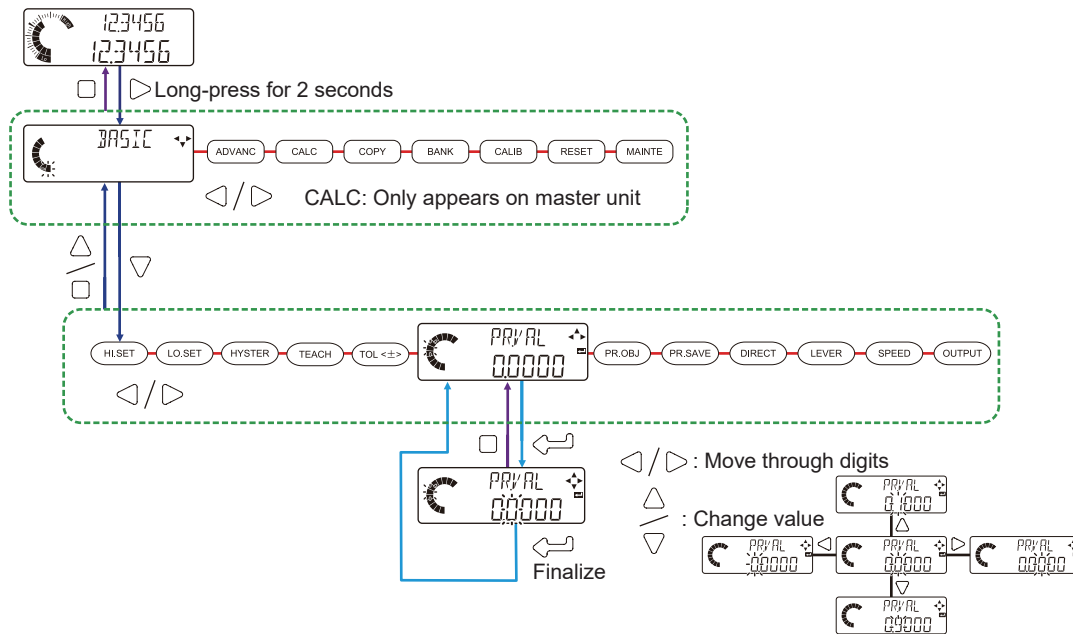

Setting item	Setting range	Default value
Preset value (PR. VAL)	-199.9999 to 199.9999 (mm)	0.0000



## 5-2-7 Preset Data Selection (PROBJ)

When using a preset, you can select the target data (NORM.V or JUDGE.V).  
 You can select "Judgment value (JUDGE.V)" to use the held value as the preset.

Preset data selection	Function
Judgment value (JUDGE.V)	The judgment value (JUDGE.V) is used as the preset value.
Normal measured value (NORM.V)	The normal measured value (NORM.V) is used as the preset value.

### <Reference>

- When a calculation function is used ("standard difference" on the master unit, or a mode other than "standard difference" on the slave unit), the setting cannot be changed.
- If a calculation function ("standard difference" on the master unit, or a mode other than "standard difference" on the slave unit) is set after preset data selection is set to "Judgment value (JUDGE.V)", the preset data will be the normal measured value (NORM.V).

### Setting method

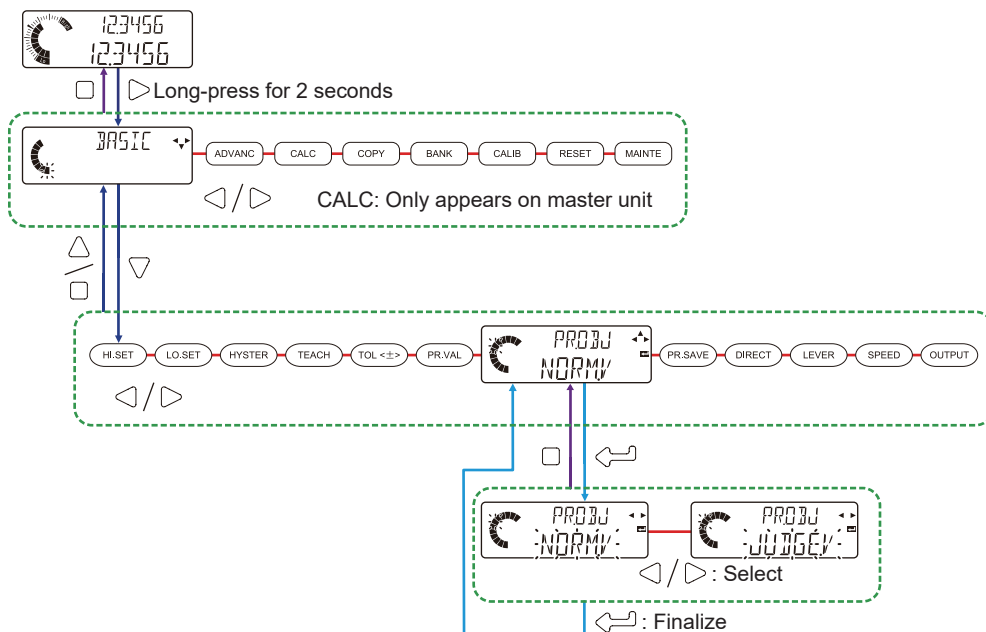

Setting item	Set values	Default value
Preset data selection (PR.OBJ)	Normal measured value (NORM.V) Judgment value (JUDGE.V)	NORM.V

## FUNCTION SETTINGS

### 5-2-8 Preset Save (PR.SAVE)

You can write preset information to EEPROM by setting preset save to ON.

The preset value is saved even when the power is turned OFF.

When the power is turned ON, the controller loads the preset ON / OFF state and offset value last saved to EEPROM.

#### <Reference>

- Data can be saved to EEPROM about 1 million times. If you do not need to save the preset value, set preset save to OFF.
- If you set preset values by key operation, the preset values are saved in internal memory and retained even after the power is turned OFF.
- To set preset values by external input, set external input to preset input.
- For preset input by external input, refer to “5-3-3 External Input (u)”.

#### Setting method

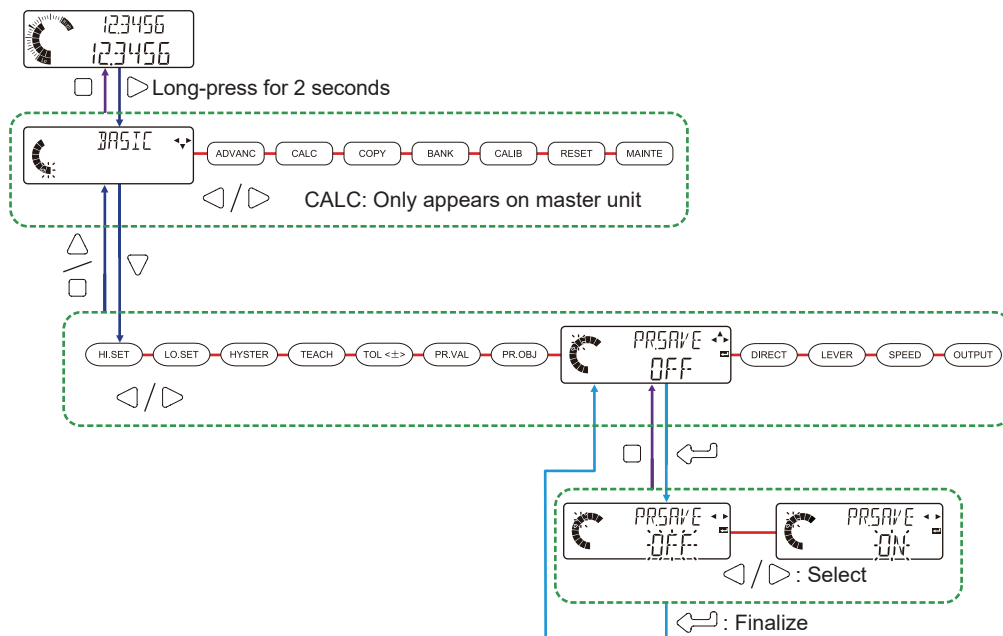

Setting item	Set values	Default value
Preset save (PR.SAVE)	Preset save OFF (OFF) Preset save ON (ON)	OFF

## 5-2-9 Measurement Direction (*DIRECT*)

You can set whether the normal measured value (NORM.V) and judgment value (JUDGE.V) are displayed normally (plus direction) or in reverse (minus direction) when the sensor head spindle is pressed in.

When set to reverse display, the HIGH set value and LOW set value are also reversed.

Measurement direction	Function
Normal display (Plus direction)	The display value increases as the spindle press-in amount (amount of movement) increases. Display: 10.0000 (mm)
Reverse display (Minus direction)	The display value decreases as the spindle press-in amount (amount of movement) increases. Display: -10.0000 (mm)

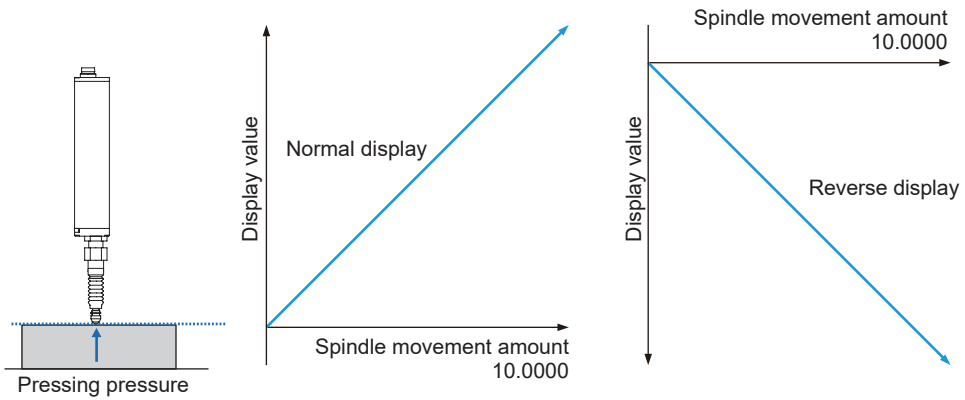

### <Reference>

If you change the measurement direction setting, you must also change the settings below.

- HIGH set value
- LOW set value
- Self trigger edge direction in the hold setting

# FUNCTION SETTINGS

## Setting method

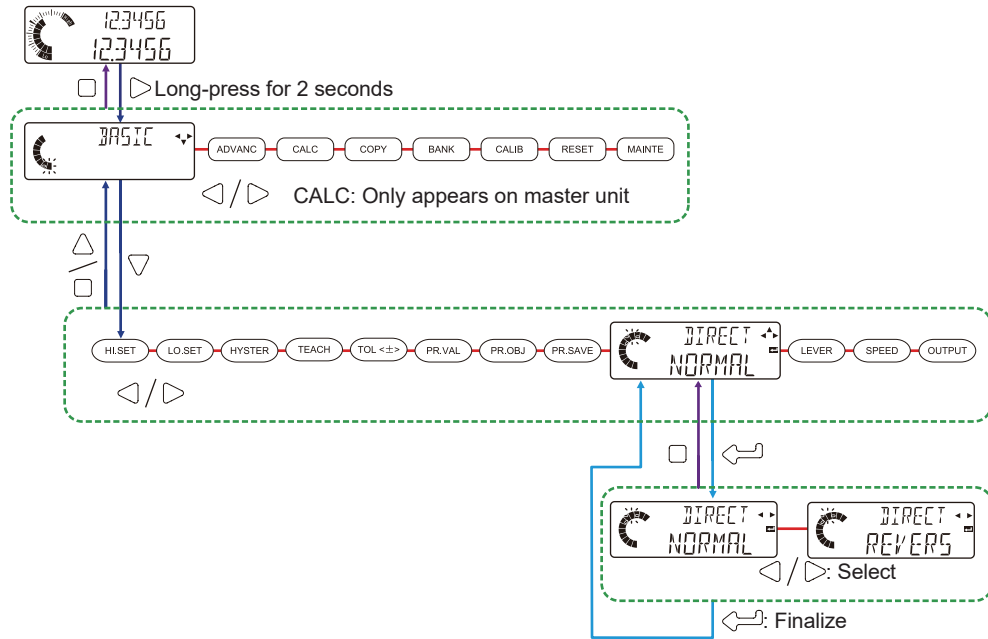

Setting item	Set values	Default value
Measurement direction (DIRECT)	Normal display (plus direction ) (NORMAL) Reverse display (minus direction) (REVERS)	NORMAL

## 5-2-10 Lever Ratio (LEVER)

When using a lever for measurement, you can output the measured value multiplied by the lever ratio as the judgment value (JUDGE.V)

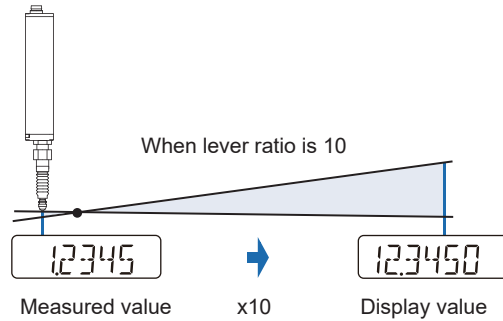

### Setting method

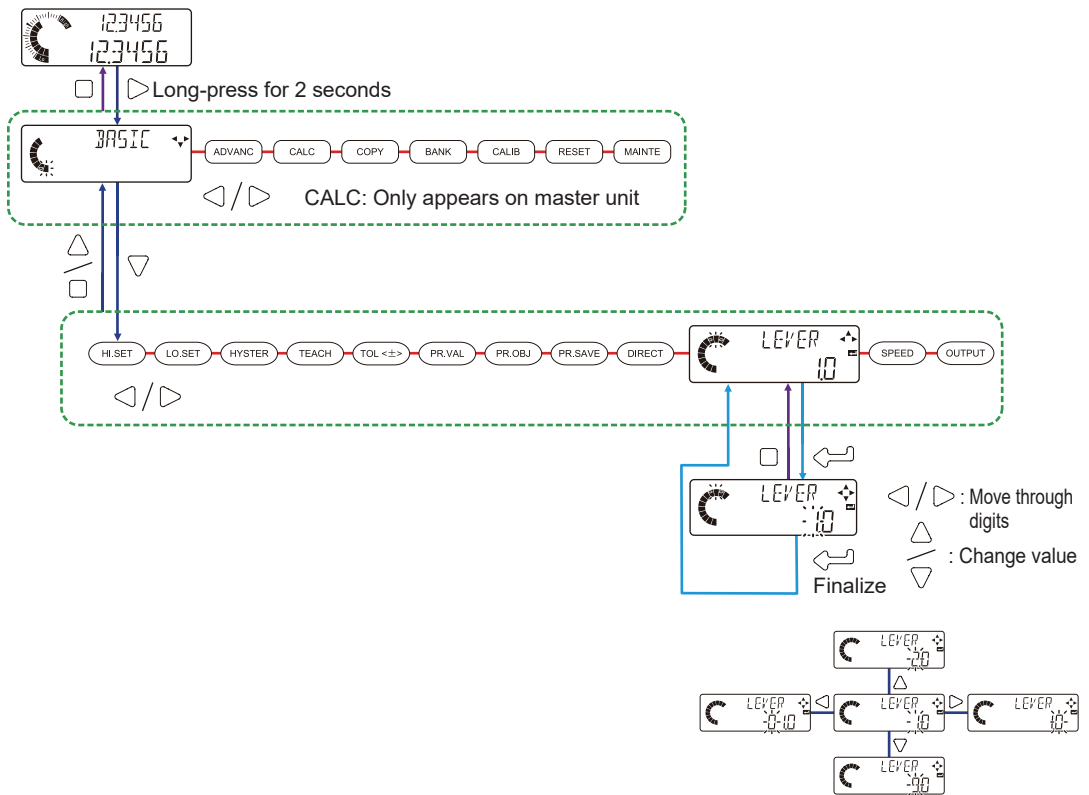

Setting item	Setting range	Default value
Lever ratio (LEVER)	0.1 to 100.0 (times)	1.0

#### <Reference>

If the lever ratio is set to a value outside the range, "\*\*\*\*\*" will appear in the digital display / MAIN (white).

You will then return to the lever ratio setting screen. Set a valid value for the lever ratio.

## FUNCTION SETTINGS

### 5-2-11 Response Time (SPEED)

You can set the time until the judgment value (JUDGE.V) is finalized (response time) when the sensor head starts measurement.

The response time setting determines the average count and average time of measurement as shown below.

Response time (ms)	Average count (repetitions)	Average time (ms)	Internal value update cycle (ms)
3	1	1	1
5	3	3	1
10	8	8	1
100	96	96	4
500	480	480	16
1,000	960	960	32

- When the response time is set to 10ms (average count 8, average time 8ms)

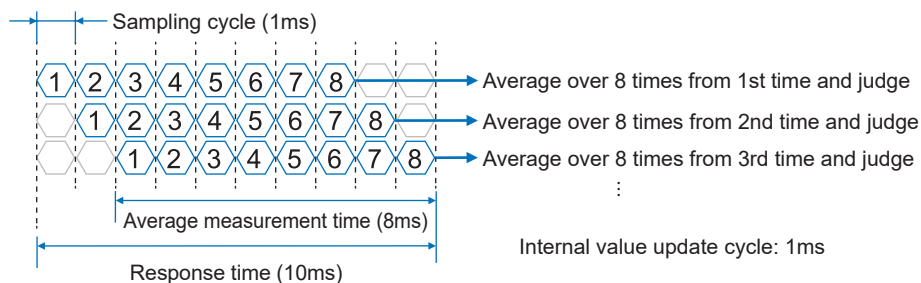

#### <Reference>

- To respond to instantaneous changes, set a shorter response time. To disregard instantaneous changes, set a longer response time.
- When the reset input is ON, the indeterminate value display shows " ....." until the average count is reached.
- If the response time is "3" (3ms), the indeterminate value display will show " ....." for 1ms.

## Setting method

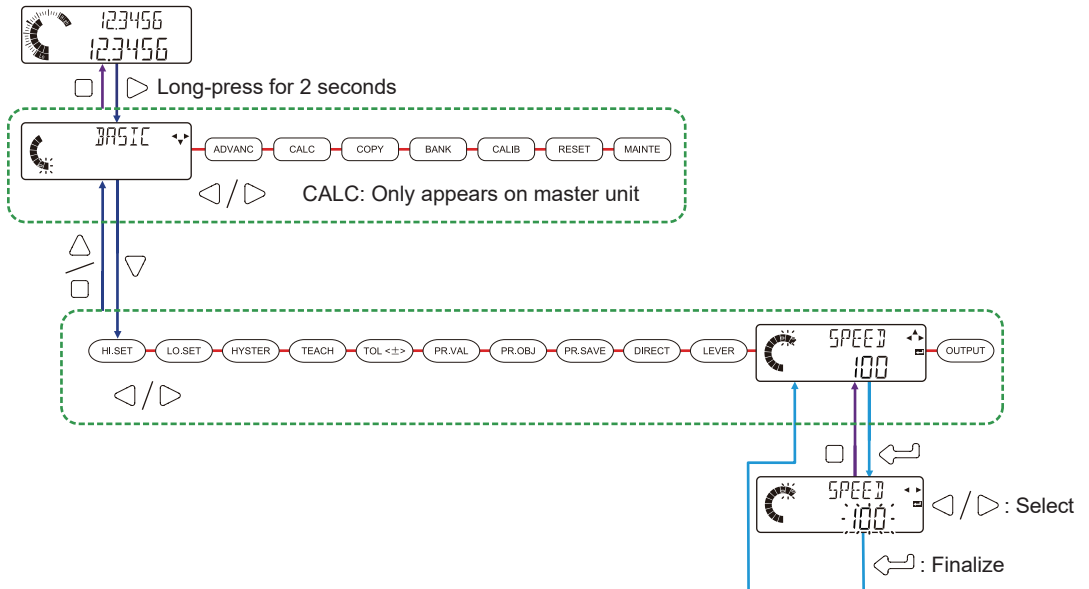

Setting item	Set values	Default value
Response time (SPEED)	3ms (3) 5ms (5) 10ms (10) 100ms (100) 500ms (500) 1,000ms (1000)	100

# FUNCTION SETTINGS

## 5-2-12 Output Operation (OUTPUT)

You can select the judgment output operation.

Output operation	Function
Normal Open (N.O.)	When the judgment is output, ON is output.
Normal Closed (N.C.)	When the judgment is output, OFF is output.

### • Example of output operation setting (GO output)

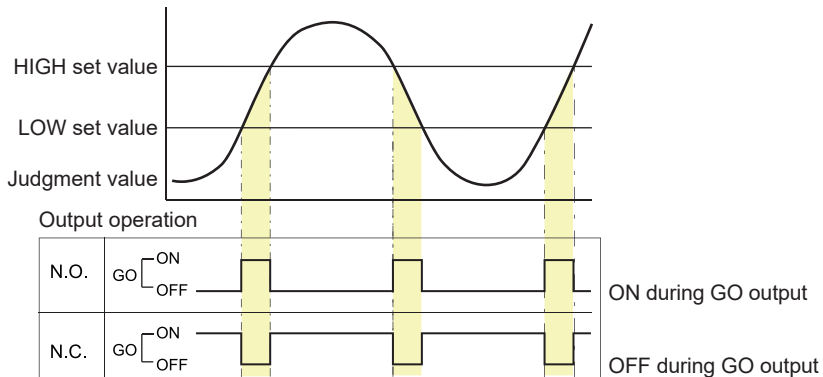

### Setting method

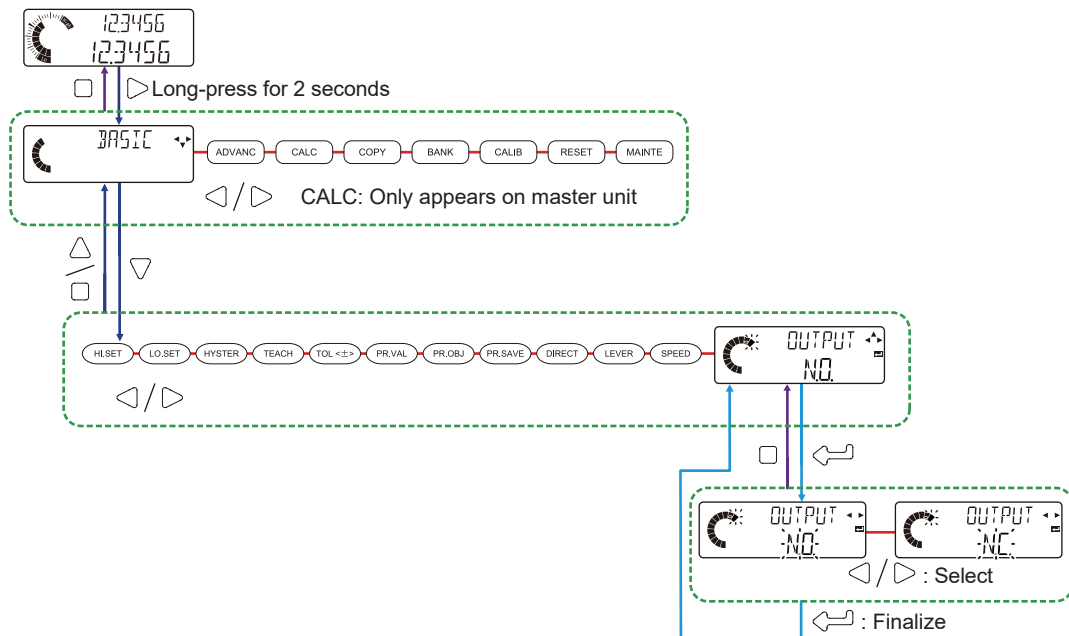

33

Setting item	Set values	Default value
Output operation (N.O. / N.C.)	Normal Open (N.O.) Normal Closed (N.C.)	N.O.



5-3 Advanced Settings (ADVANCE)

- Structure of advanced settings menu

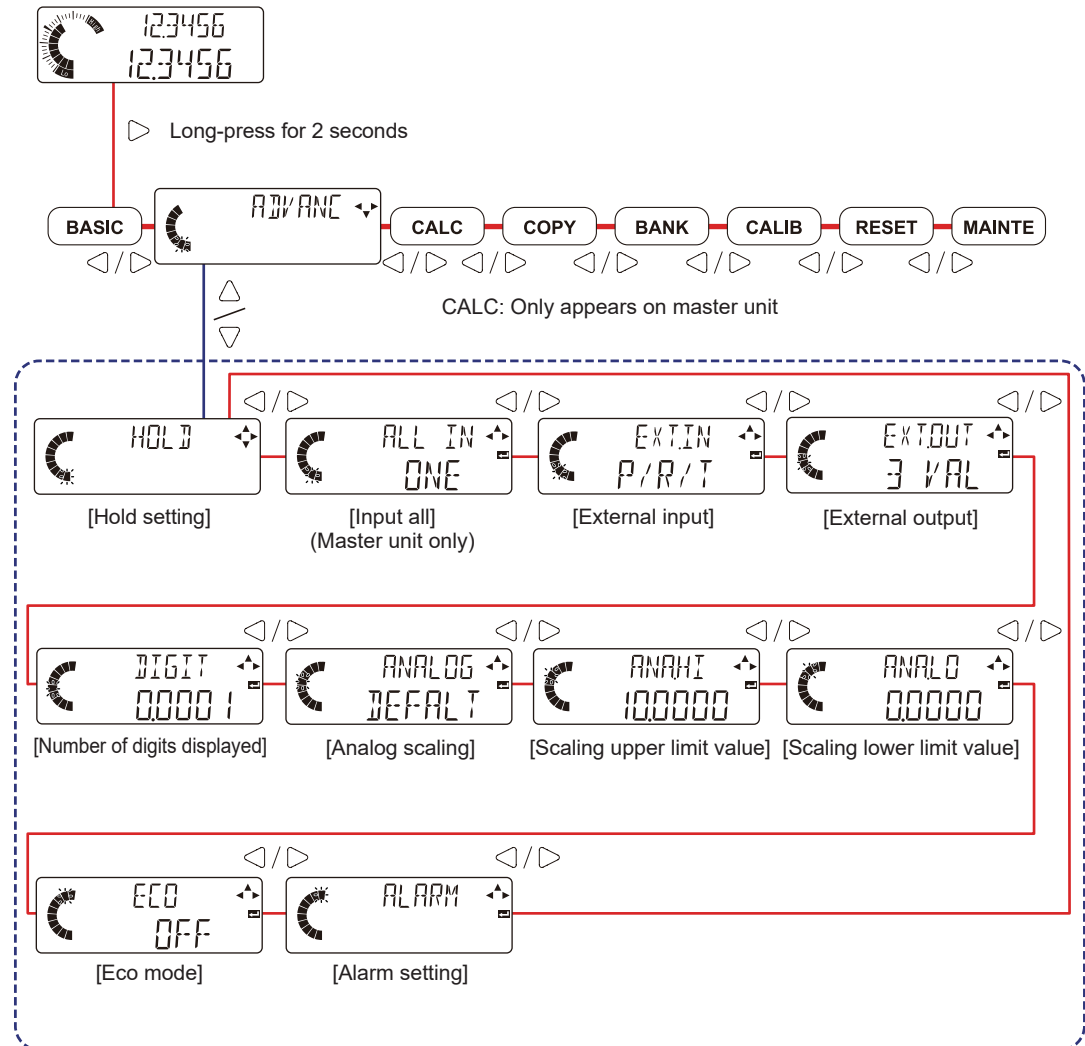

## FUNCTION SETTINGS

### 5-3-1 Hold Setting (HOLD)

Set the hold method for the judgment value (JUDGE.V).

To output the regular measured value in real-time, set the measurement mode to sample hold "S-H", and leave the external input OFF.

#### ■ Measurement Modes (MEAS)

You can select one of the following nine types for the hold mode.

Measurement mode (MEAS)	Function		External trigger input	Section
Sample hold (S-H)	Perform hold output of judgment value (JUDGE.V) only when external input is ON. When external input is OFF, update judgment value (JUDGE.V) whenever necessary and output. (Real-time output)		Valid	"Sample Hold"
Peak hold (P-H)	Perform hold output of maximum value as judgment value (JUDGE.V).		Valid	"Peak Hold, Bottom Hold, Peak to Peak Hold, Peak to Peak Hold / 2"
Bottom hold (B-H)	Perform hold output of minimum value as judgment value (JUDGE.V).		Valid	
Peak to peak hold (P-P)	Perform hold output of difference between maximum value and minimum value as judgment value (JUDGE.V).		Valid	
Peak to peak hold / 2 (P-P/2)	Perform hold output of one-half of difference between maximum value and minimum value as judgment value (JUDGE.V).		Valid	
NG hold (NG-H)	Hold LOW judgment and HIGH judgment output.		Valid	"NG Hold"
Self sample hold (SLF.S-H)	Delay timer	Perform automatic hold output of judgment value (JUDGE.V) by self trigger after delay elapses.	Invalid (Use self trigger)	"Self Sample Hold (Delay Timer)"
	Static width	Perform automatic hold output of judgment value (JUDGE.V) by self trigger after measurement fluctuation stabilizes.	Invalid (Use self trigger)	"Self Sample Hold (Static Width)"
Self peak hold (SLF.P-H)	Perform automatic hold output by self trigger of maximum value as judgment value (JUDGE.V).		Invalid (Use self trigger)	"Self Peak Hold / Self Bottom Hold"
Self bottom hold (SLF.B-H)	Perform automatic hold output by self trigger of minimum value as judgment value (JUDGE.V).		Invalid (Use self trigger)	

#### <Reference>

- When the calculation application selection function is set to "STAND" (standard difference), the hold setting on the master unit is invalid.
- Depending on the calculation application selection setting, the hold setting on the slave unit used for calculation may be invalid.

## • Sample Hold

External trigger input ON holds the judgment value (JUDGE.V). External trigger input OFF releases the hold state and the value is updated whenever necessary.

The hold action can be changed with the trigger mode setting.

For input signal combinations, see “5-3-3 External Input (u)”.

### ■ Sample Hold (Trigger mode: Hold)

Hold while external trigger input is ON.

#### Timing chart

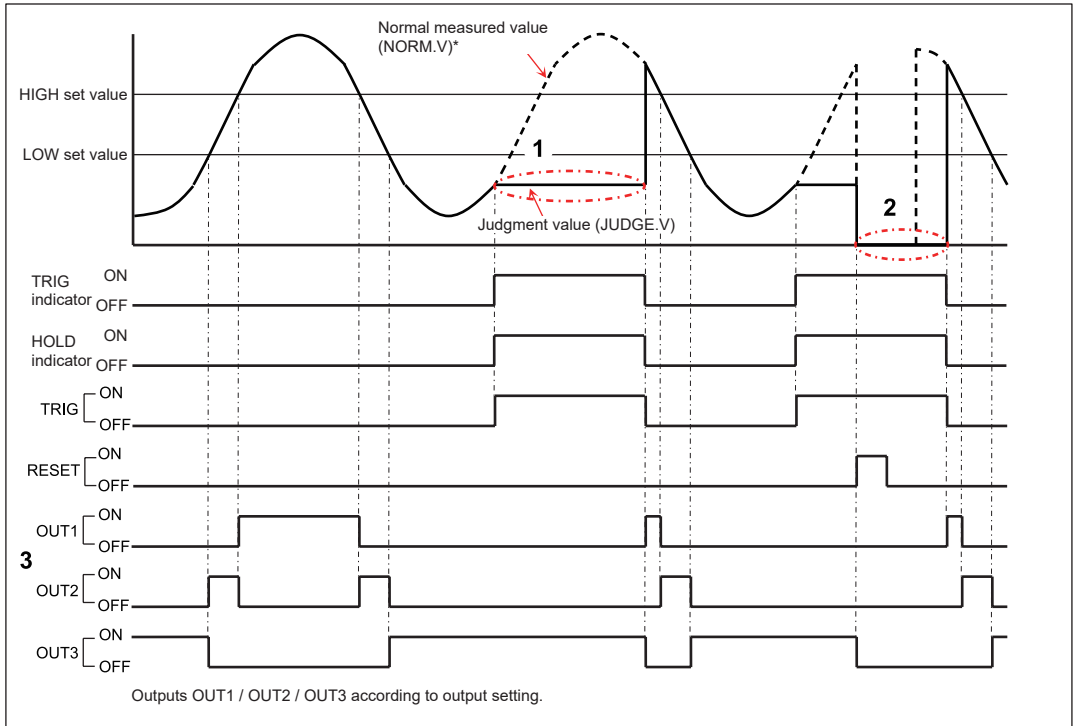

1. The judgment value (JUDGE.V) is held while the external trigger input is ON.
2. If the reset input turns ON while the external trigger input is ON, the indeterminate state is held.
3. Judgment output outputs the judgment result based on the output setting.

\*When the calculation function is used, the calculation value is “CALC”.

# FUNCTION SETTINGS

## ■ Sample Hold (Trigger mode: One-shot)

Hold is refreshed each time the external trigger input turns ON (rising edge).

### Timing chart

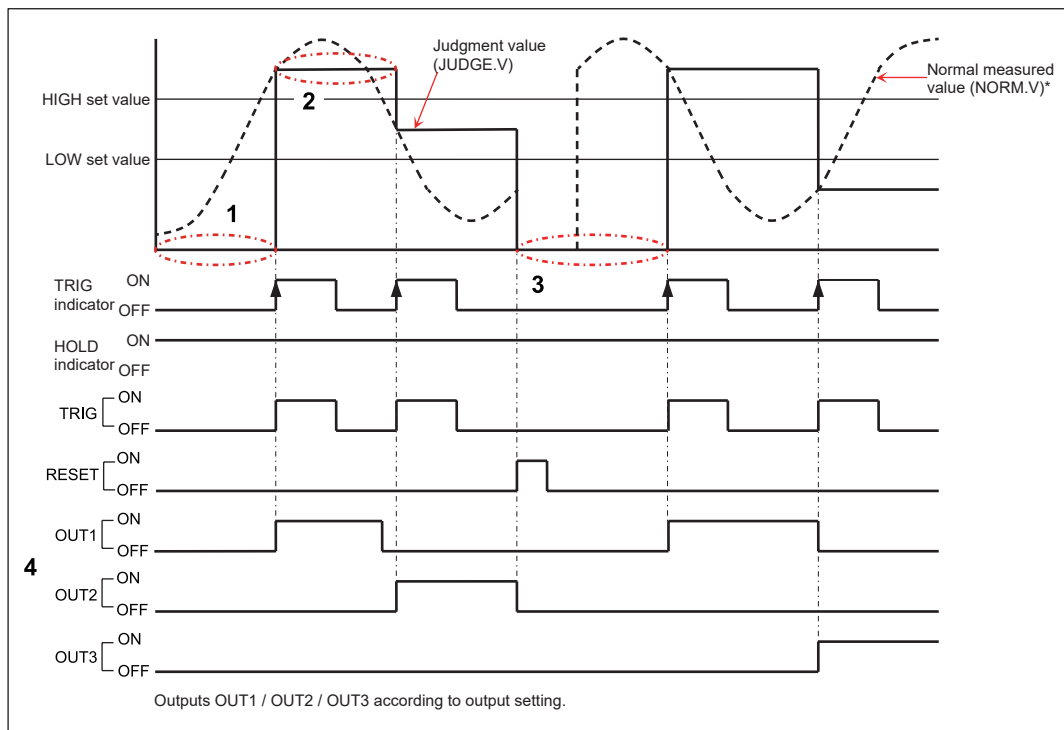

1. When the power is turned ON, the indeterminate state is held until the external trigger input turns ON.
2. When the external trigger input turns ON (rising edge), the judgment value (JUDGE.V) is held.
3. If the reset input turns ON, the indeterminate state is held.
4. Judgment output outputs the judgment result based on the output setting.

\*When the calculation function is used, the calculation value is "CALC".

### Setting item

Setting item	Set values	Default value
Measurement mode (MEAS)	Sample hold (S-H) Peak hold (P-H) Bottom hold (B-H) Peak to peak hold (P-P) Peak to peak hold / 2 (P-P/2) NG hold (NG-H) Self sample hold (SLF.S-H) Self peak hold (SLF.P-H) Self bottom hold (SLF.B-H)	S-H
Trigger mode (TRG)	Hold (HOLD) One-shot (1SHOT)	HOLD

## Setting method

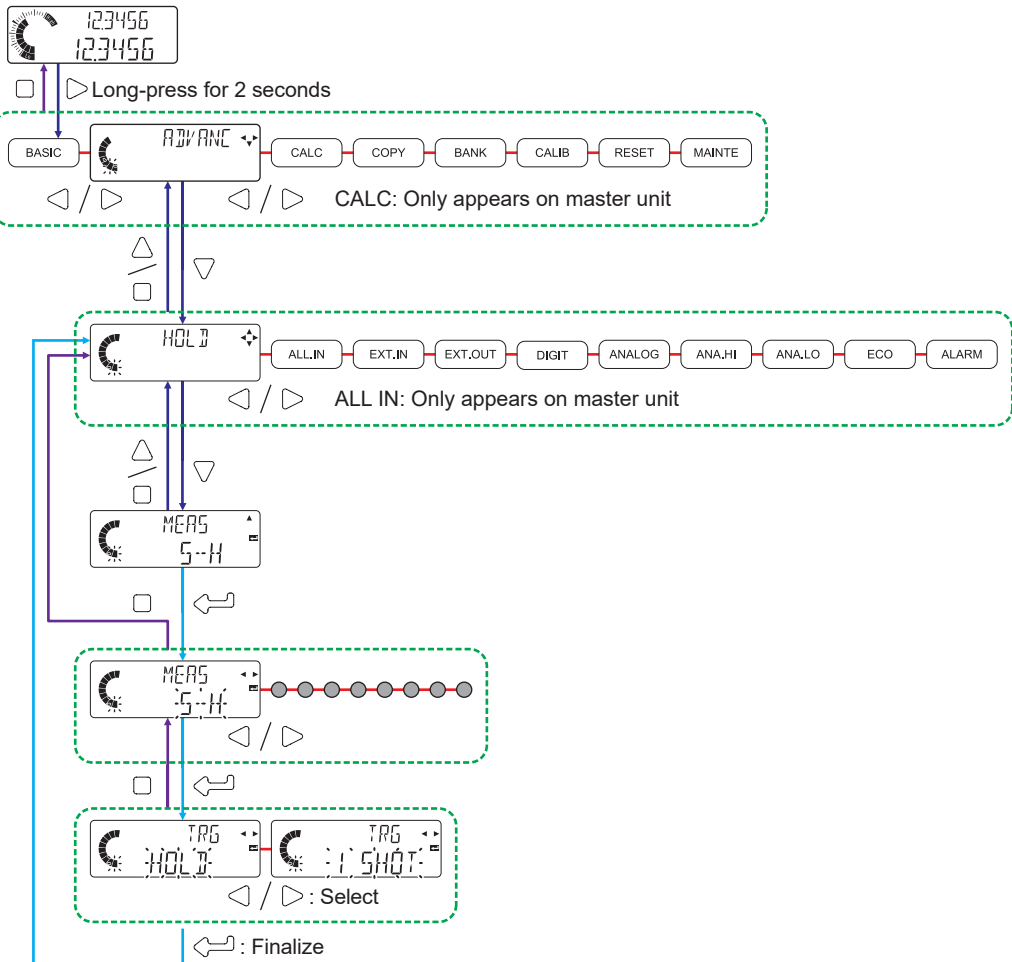

## FUNCTION SETTINGS

- **Peak Hold, Bottom Hold, Peak to Peak Hold, Peak to Peak Hold / 2**

When the external trigger turns ON, the data of any sampling interval is held as the judgment value (JUDGE.V).

The hold action can be changed with the trigger mode setting.

- **Peak Hold (Trigger mode: Hold)**

External trigger input ON starts the hold state. External trigger input OFF releases the hold state. When hold is released, the peak value is cleared and updated whenever necessary.

### Timing chart

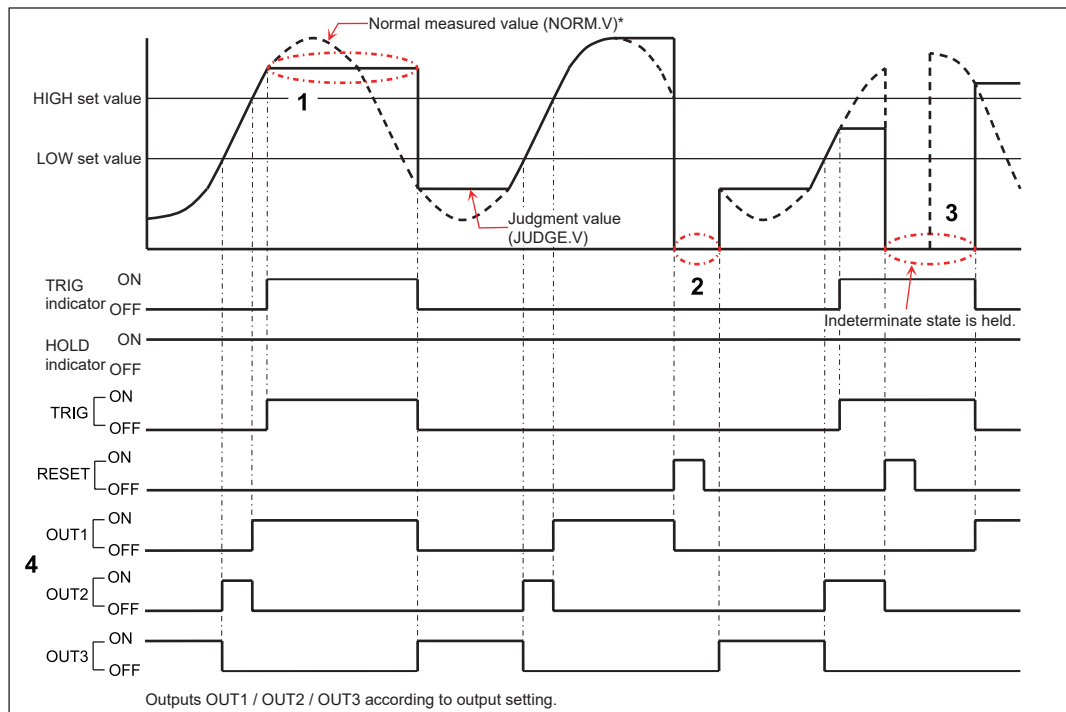

1. The judgment value (JUDGE.V) is held while the external trigger input is ON.
2. If the reset input turns ON while the external trigger input is OFF, an indeterminate state occurs during the response time.
3. If the reset input turns ON while the external trigger input is ON, the indeterminate state is held.
4. Judgment output outputs the judgment result based on the output setting.

\*When the calculation function is used, the calculation value is "CALC".

## ■ Peak Hold (Trigger mode: One-shot)

When the external trigger input is ON, the peak value during the sampling interval (external trigger input OFF interval) is held as the judgment value (JUDGE.V).

When the external trigger input turns OFF, the next sampling interval starts.

### Timing chart

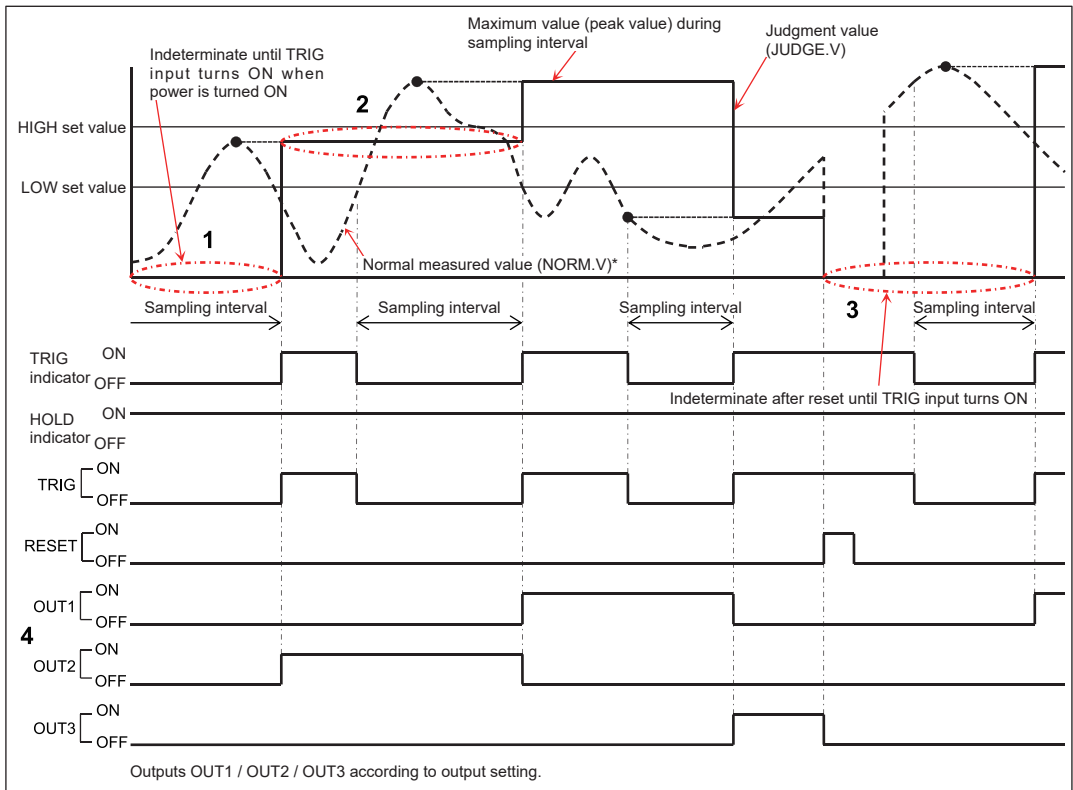

1. When the power is turned ON, the indeterminate state is held until the external trigger input turns ON.
2. When the external trigger input turns ON (rising edge), the maximum normal measured value (NORM.V) that occurs during the sampling interval is held as the judgment value (JUDGE.V).
3. If the reset input turns ON, the indeterminate state is held.
4. Judgment output outputs the judgment result based on the output setting.

\*When the calculation function is used, the calculation value is "CALC".

#### <Reference>

The judgment value (JUDGE.V) is held in the same way in the respective measurement modes of Bottom hold, Peak to peak hold, and Peak to peak hold / 2.

# FUNCTION SETTINGS

## Setting item

Setting item	Set values	Default value
Measurement mode (MEAS)	Sample hold (S-H) Peak hold (P-H) Bottom hold (B-H) Peak to peak hold (P-P) Peak to peak hold / 2 (P-P/2) NG hold (NG-H) Self sample hold (SLF.S-H) Self peak hold (SLF.P-H) Self bottom hold (SLF.B-H)	S-H

Setting item	Set values	Default value
Trigger mode (TRG)	Hold (HOLD) One-shot (1SHOT)	HOLD

## Setting method

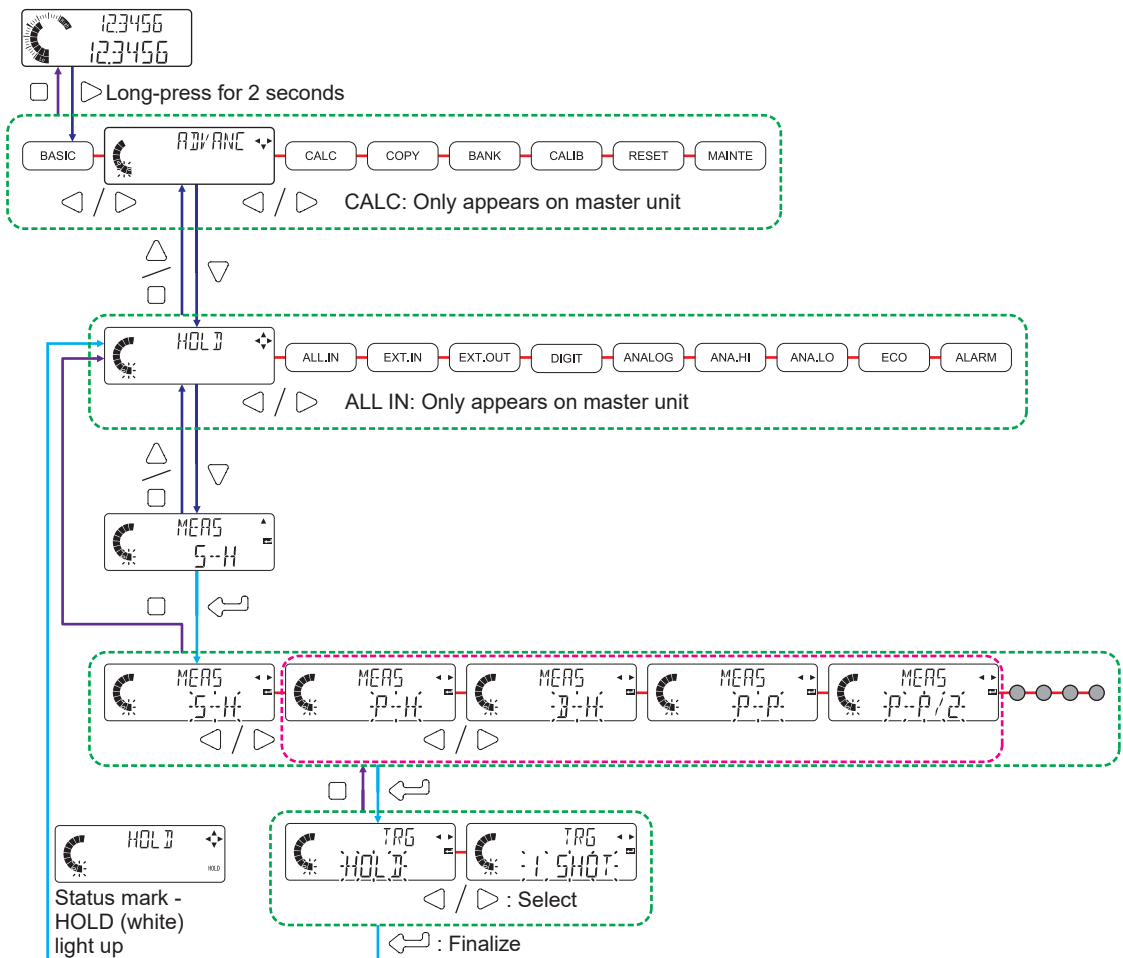



## • NG Hold

If a HIGH judgment or LOW judgment occurs during the interval specified by the external trigger (TRIG input OFF interval), the judgment output is held. The judgment value (JUDGE.V) is not held.

### Timing chart

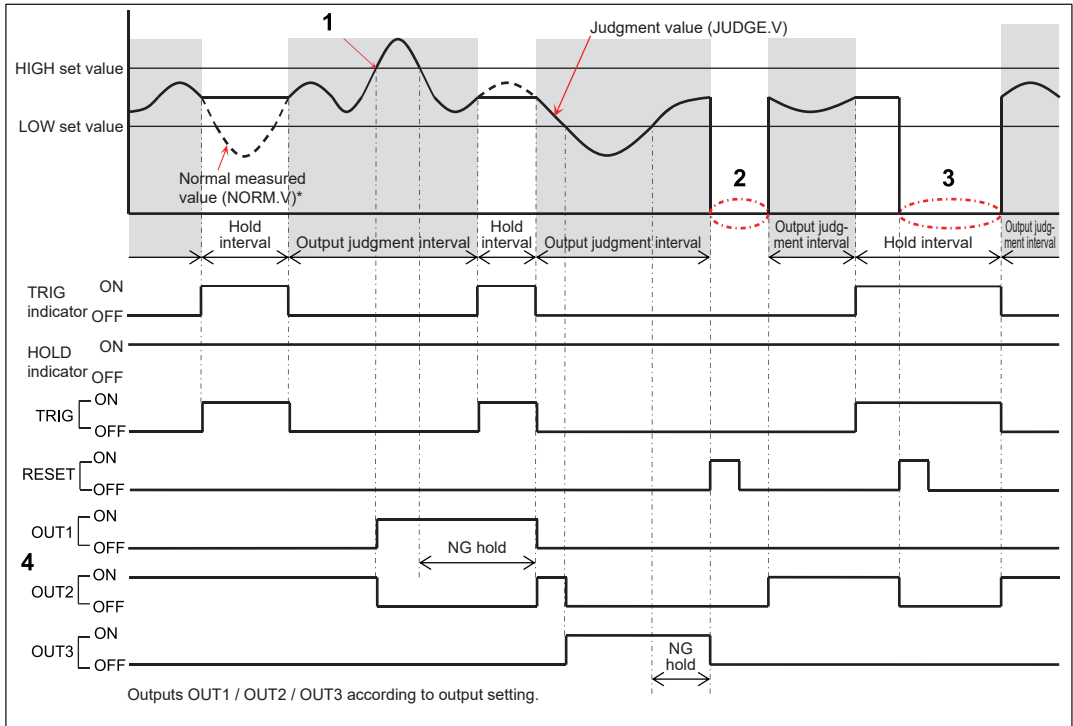

1. The judgment output is held when the external trigger is OFF, but the judgment value (JUDGE.V) is not held. The judgment output hold state is released by reset input. While the external trigger is ON, the judgment value (JUDGE.V) and judgment output are held.
2. Reset input causes the judgment value (JUDGE.V) to become indeterminate until the average count is reached.
3. If the reset input turns ON while the external trigger is ON, the indeterminate state is held. If a setting change causes the response time or judgment value (JUDGE.V) to change while the external trigger is ON, reset occurs and the indeterminate state is held.
4. Judgment output outputs the judgment result according to the output setting.

#### <Reference>

- Once a HIGH judgment is output during one output judgment interval, a LOW judgment is not output.  
Once a LOW judgment is output, a HIGH judgment is not output.
- The trigger mode setting is invalid for NG hold.

# FUNCTION SETTINGS

## Setting item

Setting item	Set values	Default value
Measurement mode (MEAS)	Sample hold (S-H) Peak hold (P-H) Bottom hold (B-H) Peak to peak hold (P-P) Peak to peak hold / 2 (P-P/2) NG hold (NG-H) Self sample hold (SLF.S-H) Self peak hold (SLF.P-H) Self bottom hold (SLF.B-H)	S-H

## Setting method

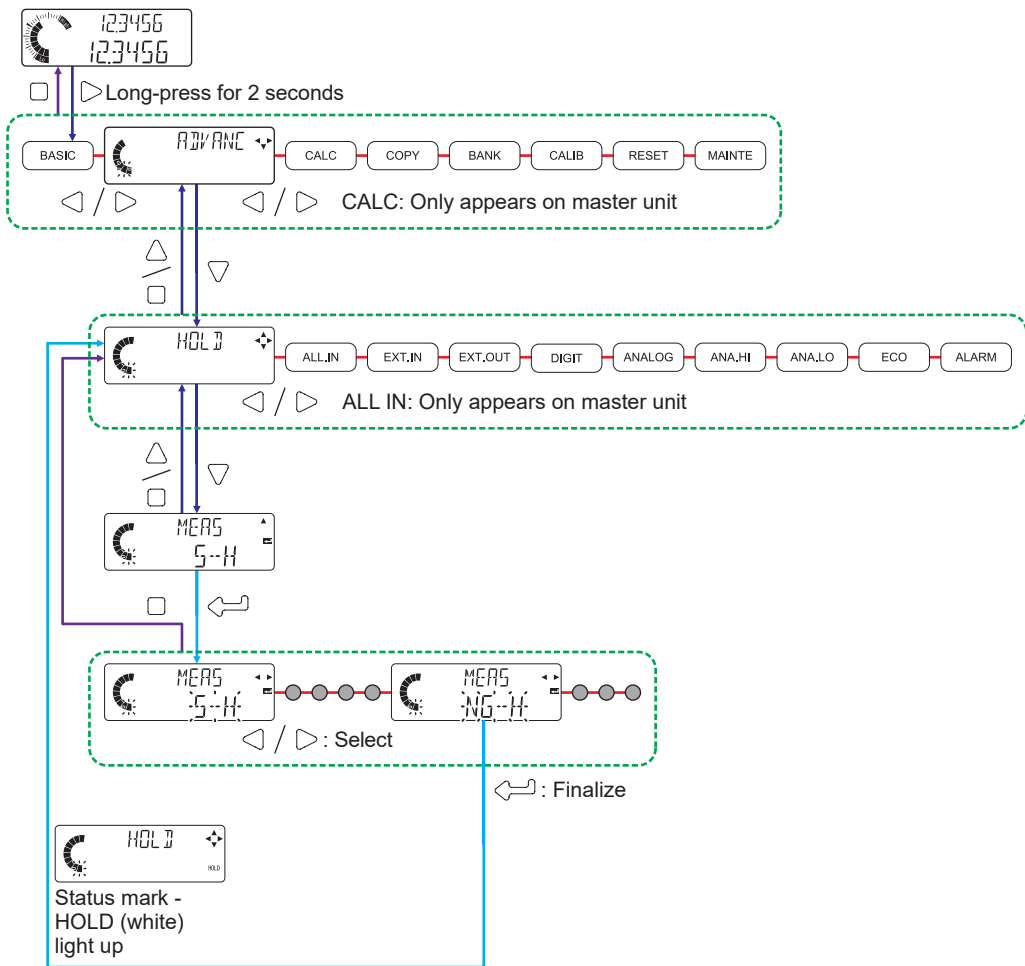

## • Self Sample Hold (Delay Timer)

The normal measured value (NORM.V) can be held automatically as the judgment value (JUDGE.V) when the delay time elapses after the specified self trigger level is exceeded.

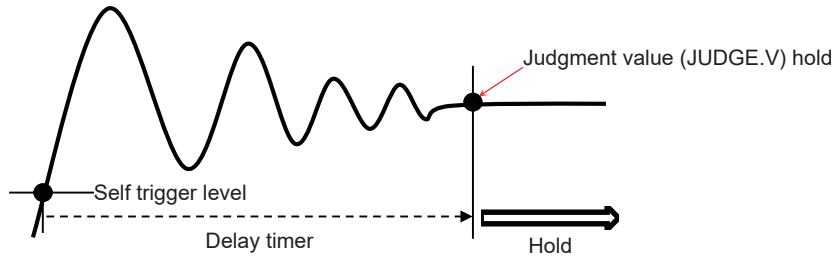

### Timing chart

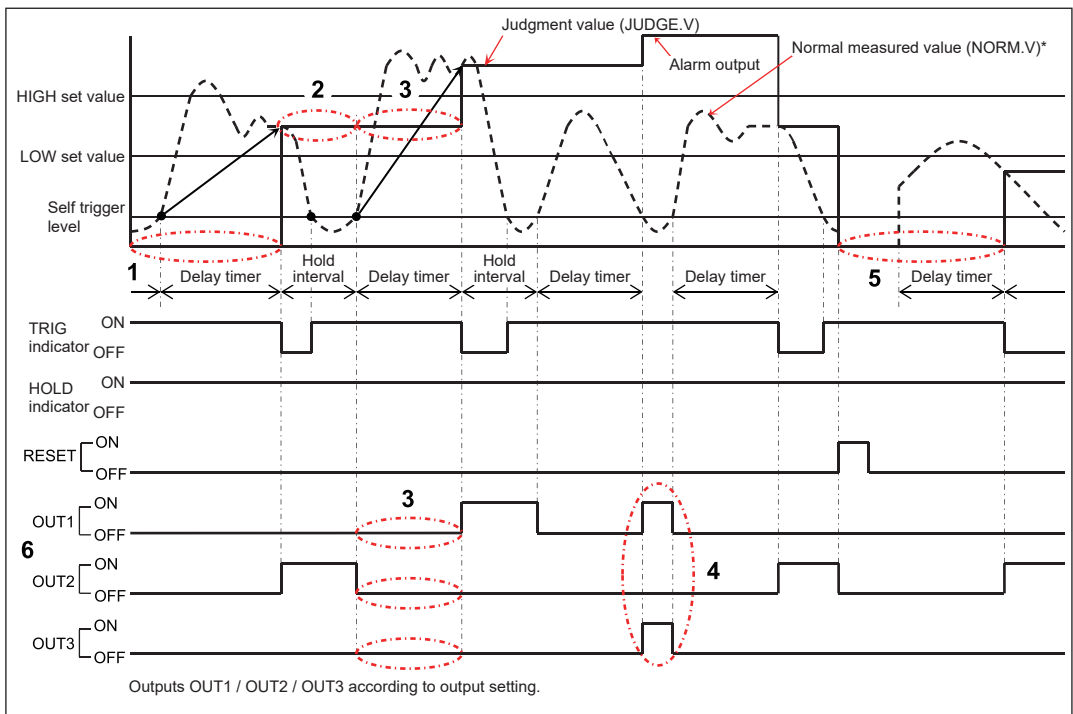

1. The previous value is held until the delay time elapses. (When the power is turned ON, the indeterminate state is held.)
2. After the delay time elapses, the normal measured value (NORM.V) is held as the judgment value (JUDGE.V) until the next self trigger action.
3. During the delay time, the judgment value (JUDGE.V) is held while all judgment outputs turn OFF.
4. Before the delay time elapses, an alarm state occurs if the normal measured value (NORM.V) falls below the self trigger level. (When the self trigger edge direction is "UP".)
5. If the reset input turns ON, the indeterminate state is held. If this occurs during the delay time, the delay time ends.
6. Judgment output outputs the judgment result based on the output setting.

## FUNCTION SETTINGS

\*When the calculation function is used, the calculation value is "CALC".

### <Reference>

- When self sample hold is selected, external trigger input is invalid.
- When a sensor head not connected error or pressure alarm / error is cleared, the same action as a reset takes place.

### Setting item

#### • Self trigger level (SLF.LV)

You can set the delay timer start level.

\* The self trigger level setting for self sample hold (delay timer) sets the level for start of the delay.

Setting item	Set values / setting range	Default value
Self trigger level (SLF.LV)	-199.9999 to 199.9999 (mm)	0.5000

#### • Self trigger edge direction (SLF.EDG)

You can set the edge direction for the self trigger.

Setting item	Set values / setting range	Default value
Self trigger edge direction (SLF.EDG)	Rise (UP) Fall (DOWN)	UP

#### • Self trigger delay (SLF.DLY)

You can set whether the normal measured value (NORM.V) is held after it stabilizes, or after the delay time elapses.

Setting item	Set values / setting range	Default value
Self trigger delay (SLF.DLY)	Static width (DLY.WD) Delay timer (DLY.TIM)	DLY.WD

#### • Delay timer (DLY.TIM)

You can set a delay time for holding of the value.

Setting item	Set values / setting range	Default value
Delay timer (DLY.TIM)	0 to 9999 (ms)	1000



## FUNCTION SETTINGS

### • Self Sample Hold (Static Width)

The normal measured value (NORM.V) can be held automatically as the judgment value (JUDGE.V) when the measured value becomes less than the specified static width (within the fluctuation stabilization interval) after the specified self trigger level is exceeded.

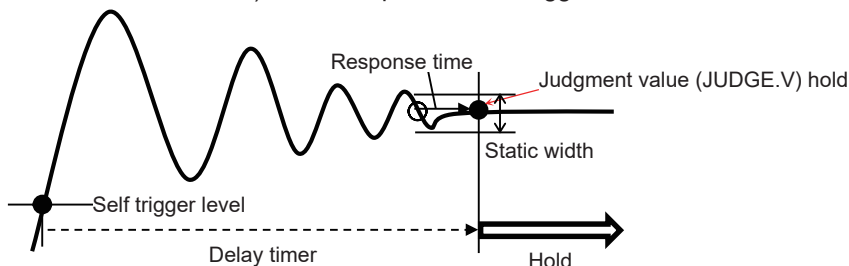

### Timing chart

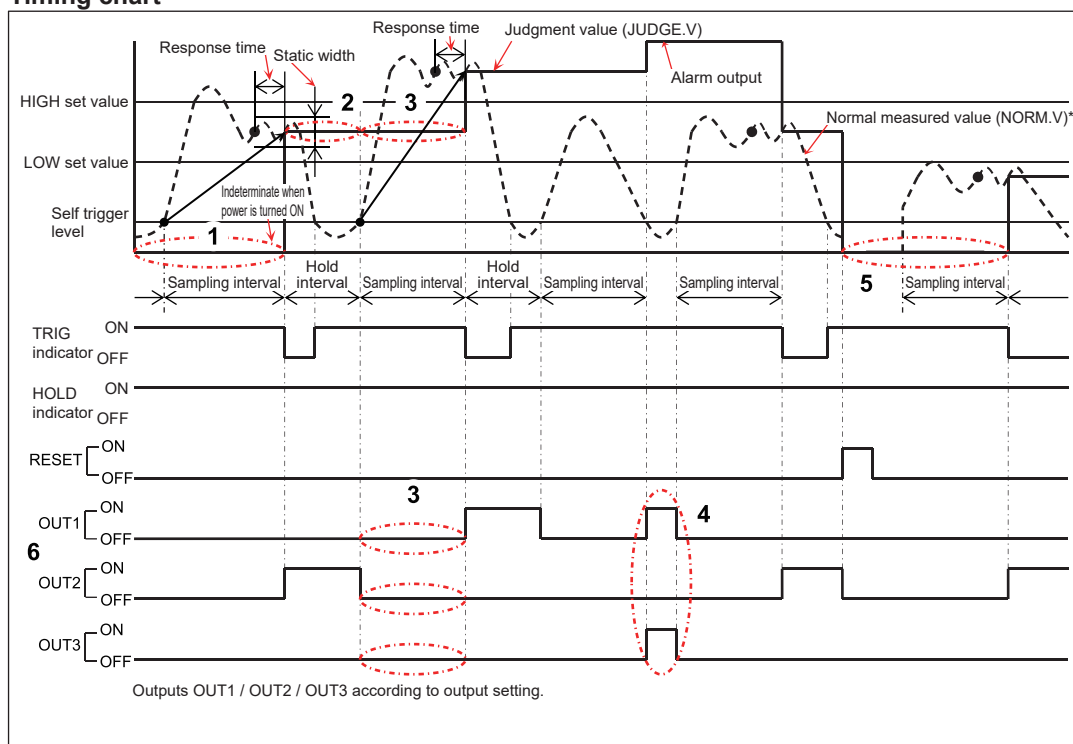

1. After the measurement value drops below the static width (fluctuation stabilizes), the previous value is held until the response time elapses. (When the power is turned ON, the indeterminate state is held.)
2. After holding starts, the normal measured value (NORM.V) is held as the judgment value (JUDGE.V) until the next self trigger action.
3. During the sampling interval, the judgment value (JUDGE.V) is held while all judgment outputs turn OFF.
4. Before entering the static width, an alarm state occurs if the normal measured value (NORM.V) falls below the self trigger level. (When the self trigger edge direction is "UP".)
5. If the reset input turns ON, the indeterminate state is held. If within the sampling interval, the sampling interval ends.
6. Judgment output outputs the judgment result based on the output setting.

\*When the calculation function is used, the calculation value is "CALC".

**<Reference>**

- When self sample hold is selected, external trigger input is invalid.
- When a sensor head not connected error or pressure alarm / error is cleared, the same action as a reset takes place.

**Setting item**

● **Self trigger level (SLF.LV)**

You can set the level that starts stabilization diagnosis of the normal measured value (NORM.V).

\* The self trigger level setting for self sample hold (static width) sets the level for start of stabilization diagnosis of the internal judgment value.

Setting item	Set values / setting range	Default value
Self trigger level (SLF.LV)	-199.9999 to 199.9999 (mm)	0.5000

● **Self trigger edge direction (SLF.EDG)**

You can set the edge direction for triggering of the self trigger.

Setting item	Set values / setting range	Default value
Self trigger edge direction (SLF.EDG)	Rise (UP) Fall (DOWN)	UP

● **Self trigger delay (SLF.DLY)**

You can set whether the normal measured value (NORM.V) is held after it stabilizes, or after the delay time elapses.

Setting item	Set values / setting range	Default value
Self trigger delay (SLF.DLY)	Static width (DLY.WD) Delay timer (DLY.TIM)	DLY.WD

● **Static width (DLY.WD)**

You can set the static width (allowed fluctuation width) of the normal measured value (NORM.V).

Setting item	Set values / setting range	Default value
Static width (DLY.WD)	0 to 199.9999 (mm)	0.01

# FUNCTION SETTINGS

## Setting method

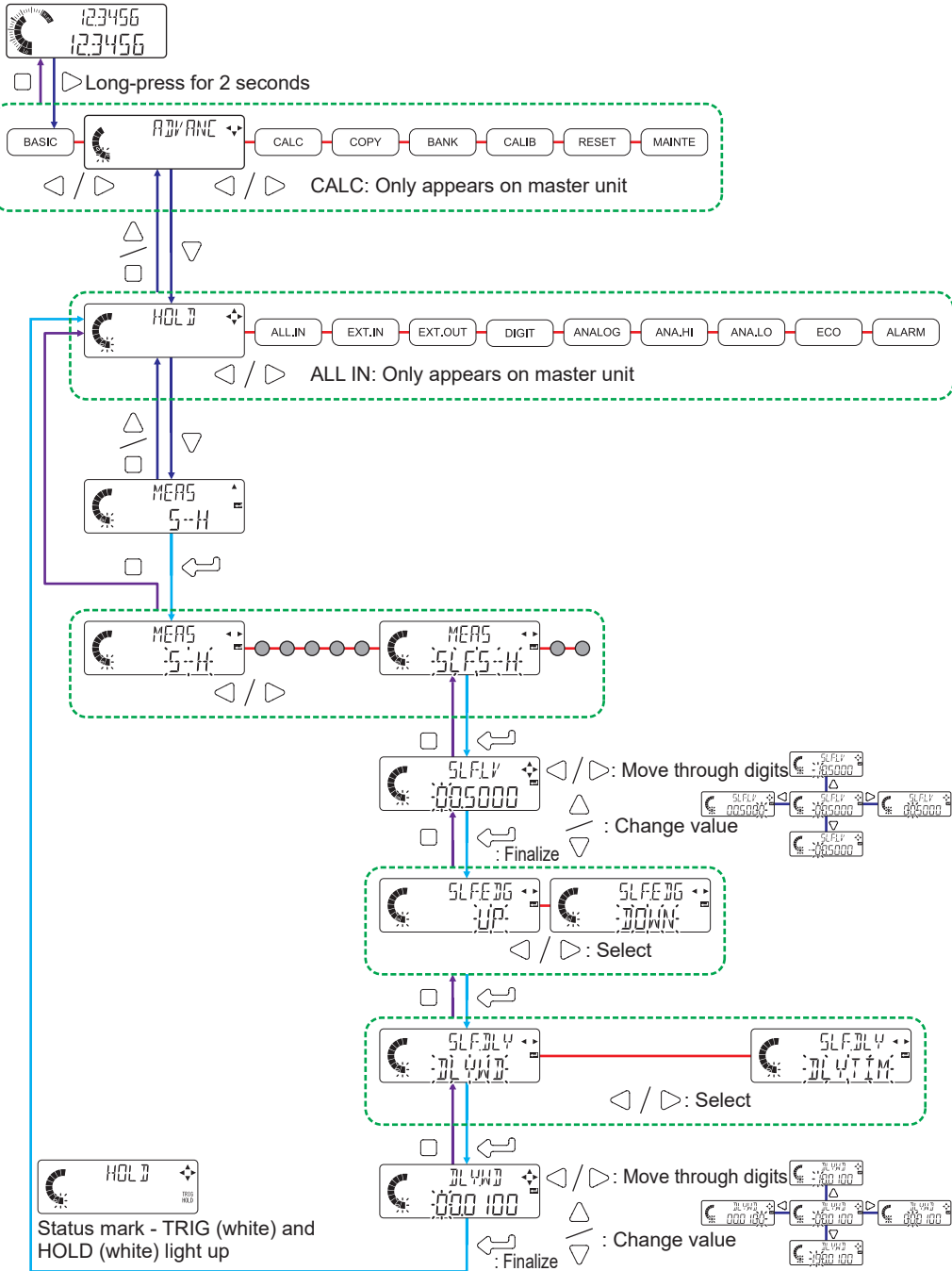



## ● Self Peak Hold / Self Bottom Hold

At the end of self trigger start, the data of the sampling interval is automatically held as the judgment value (JUDGE.V).

The hold action can be changed with the trigger mode setting.

### ■ Self Peak Hold (Trigger mode: Hold)

After the end of self trigger, the peak value during the sampling interval (the interval from the end to the start of self trigger) is held as the judgment value (JUDGE.V).

The hold state is released at the start of self trigger.

When hold is released, the peak value is cleared and updated whenever necessary.

Self trigger starts when the value rises above (falls below) the self trigger level.

Self trigger ends when the value falls below (rises above) the self trigger level.

### Timing chart

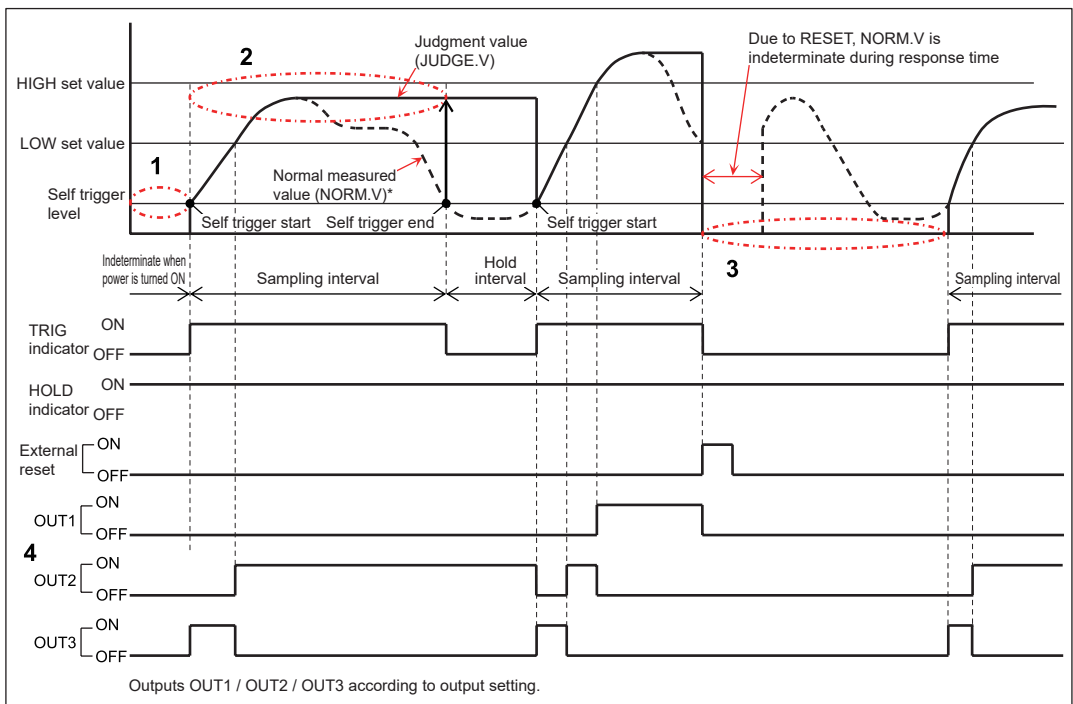

1. The previous value is held until the self trigger level is exceeded and self trigger starts. (When the power is turned ON, the indeterminate state is held.)
2. After hold is released with the start of self trigger, the peak value of the normal measured value (NORM.V) is updated as the judgment value (JUDGE.V) whenever necessary during the sampling interval.
3. If the reset input turns ON, the indeterminate state is held. If within the sampling interval, the sampling interval ends.
4. Judgment output outputs the judgment result based on the output setting.

\*When the calculation function is used, the calculation value is "CALC".

## FUNCTION SETTINGS

### <Reference>

- When self peak hold or self bottom hold is selected, external trigger input is invalid.
- When a sensor head not connected error or pressure alarm / error is cleared, the same action as a reset takes place.

### ■ Self Peak Hold (Trigger mode: One-shot)

After the end of self trigger, the peak value during the sampling interval (the interval from the end to the start of self trigger) is held as the judgment value (JUDGE.V).

When self trigger starts, the next sampling interval starts.

Self trigger starts when the value rises above (falls below) the self trigger level.

Self trigger ends when the value falls below (rises above) the self trigger level.

### Timing chart

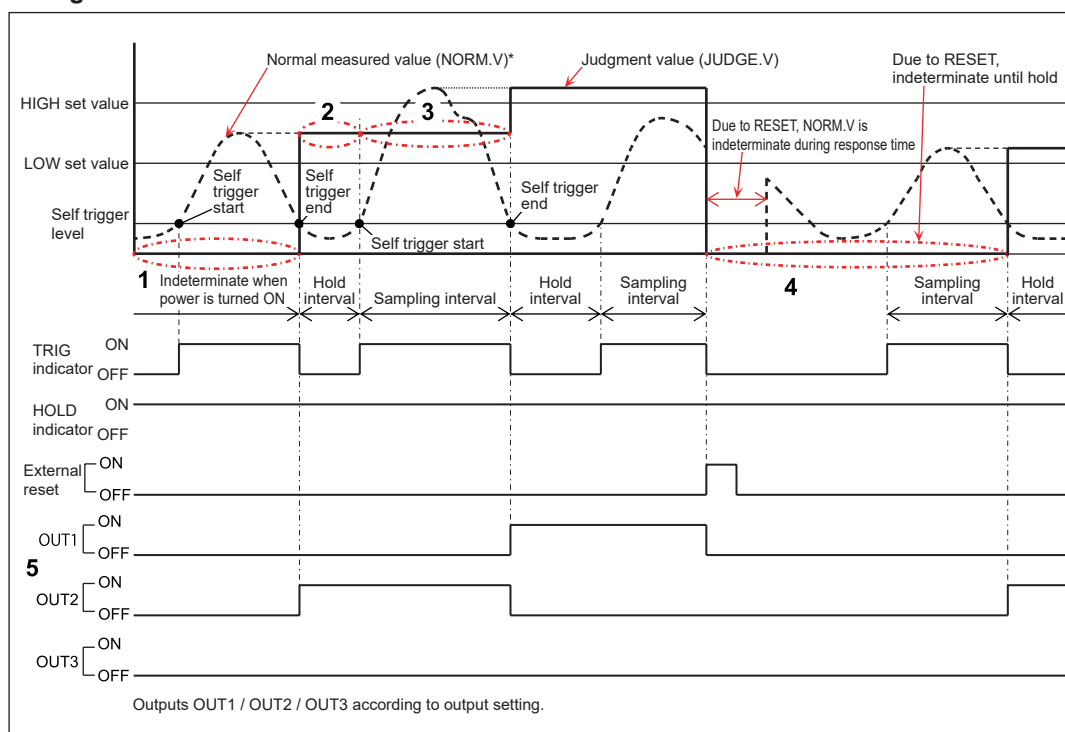

1. When the power is turned ON, the indeterminate state is held until self trigger ends.
2. When self trigger ends, the maximum normal measured value (NORM.V) that occurs during the sampling interval is held as the judgment value (JUDGE.V).
3. The previous value is held from the start of self trigger to the end (sampling interval).
4. If the reset input turns ON, the indeterminate state is held. If within the sampling interval, the sampling interval ends.
5. Judgment output outputs the judgment result based on the output setting.

**<Reference>**

- When self peak hold or self bottom hold is selected, external trigger input is invalid.
- When a sensor head not connected error or pressure alarm / error is cleared, the same action as a reset takes place.
- The judgment value (JUDGE.V) is held in the same way in the measurement modes of self bottom hold.

**Setting items**

• **Trigger mode (TRG)**

The hold action during the sampling interval can be set.

- When “HOLD” is selected, the peak value is updated whenever necessary during the sampling interval.
- When “1SHOT” is selected, the peak value is held during the sampling interval as well.

Setting item	Set values / setting range	Default value
Trigger mode (TRG)	Hold (HOLD) One-shot (1SHOT)	HOLD

• **Self trigger level (SLF.LV)**

You can set the level that starts stabilization diagnosis of the normal measured value (NORM.V).

Setting item	Set values / setting range	Default value
Self trigger level (SLF.LV)	-199.9999 to 199.9999 (mm)	0.5000

• **Self trigger edge direction (SLF.EDG)**

You can set the edge direction for triggering of the self trigger.

Setting item	Set values / setting range	Default value
Self trigger edge direction (SLF.EDG)	Rise (UP) Fall (DOWN)	UP

# FUNCTION SETTINGS

## Setting method

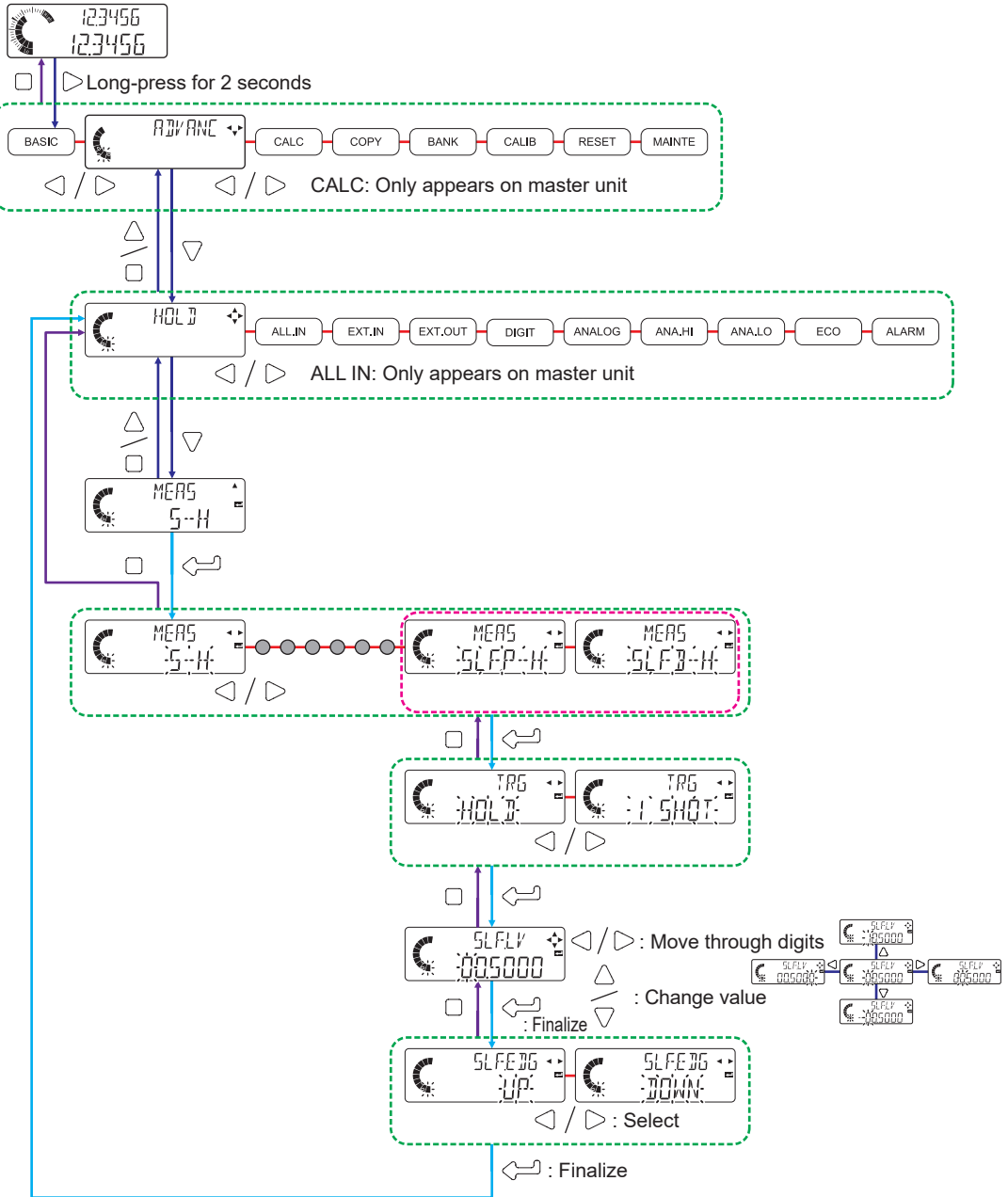

## 5-3-2 Input All (ALL IN) (Master Unit Only)

You can enable ALL IN on the master unit to input trigger input, preset input, and other signals into all connected slave units.

Input All	Function
Single (ONE)	Perform master and slave unit external input individually. External signals are input into each slave unit according to the external input setting.
All (ALL)	When a signal is input into the master unit, the same signal is input into all connected slave units. The same signals are input into the slave units as the master unit, regardless of the external input setting.

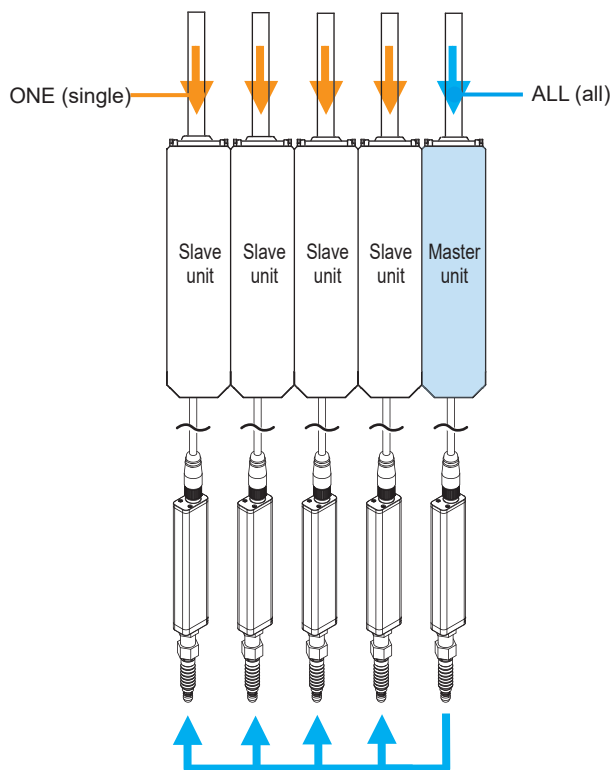

### <Reference>

Input All can only be set on a master unit to which slave units are connected.

# FUNCTION SETTINGS

## Setting method

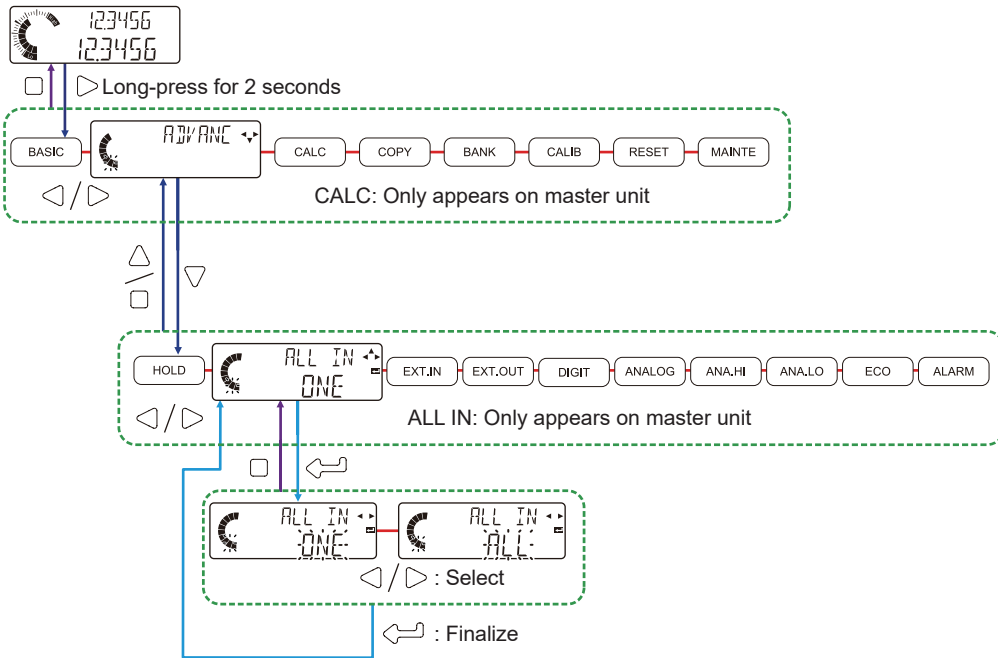

Setting item	Set values	Default value
Input all (ALL IN)	Single (ONE) All (ALL)	ONE

## 5-3-3 External Input (EXTIN)

You can select from four combinations for the signals that are input into input 1 / input 2 / input 3 of external input.

External input setting combinations are shown below.

External input	Input signal combination		
	Input 1 (Pink)	Input 2 (Violet)	Input 3 (Pink / Violet)
Preset / Reset / Trigger (P/R/T)	Preset	Reset	Trigger
Bank A / Bank B / Preset (BANK/P)	Bank A	Bank B	Preset
Bank A / Bank B / Reset (BANK/R)	Bank A	Bank B	Reset
Bank A / Bank B / Trigger (BANK/T)	Bank A	Bank B	Trigger

### • Minimum input time

The minimum input time depends on the input type.

#### <Preset input>



#### <Reset input>

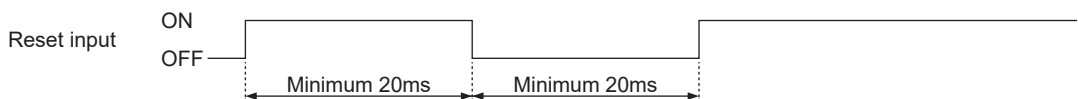

#### <Trigger input>

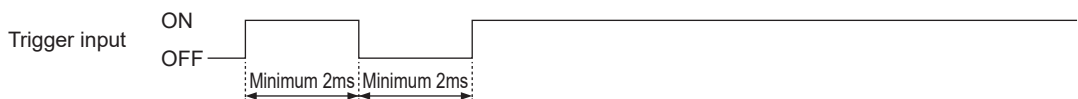

#### <Bank A / B input>

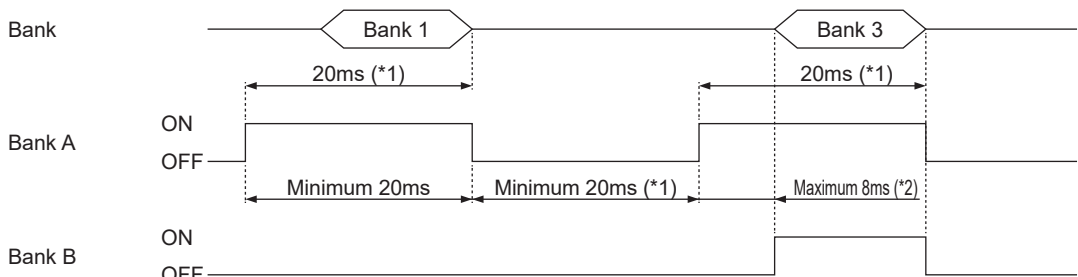

\*1: Minimum of 50ms when bank save is set to "ALL".

\*2: If more than 8ms elapses, data may be read from bank 1 and then bank 2.

#### <Reference>

- For controller I/O circuit diagrams, refer to "3-6-2 I/O Circuit Diagrams".
- For input all, refer to "5-3-2 Input All (ALL IN) (Master Unit Only)".

# FUNCTION SETTINGS

## Setting method

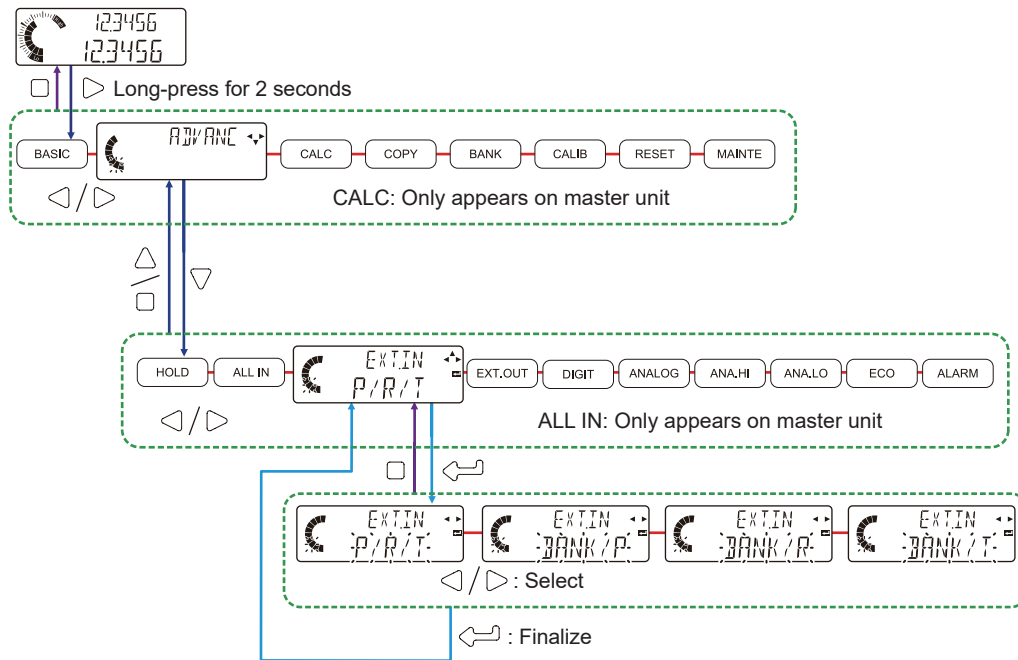

Setting item	Set values	Default value
External input (EXT.IN)	Preset / Reset / Trigger (P/R/T) Bank A / Bank B / Preset (BANK/P) Bank A / Bank B / Reset (BANK/R) Bank A / Bank B / Trigger (BANK/T)	P/R/T





## 5-3-4 External Output (EXTOUT)

You can select from four combinations for the signals that are output into output 1 / output 2 / output 3 of external output.

This product has an alarm signal output function. Alarm signals enable prompt action when the sensor head is not operating correctly.

When "3-value (3 VAL)" is selected, the alarm outputs a HIGH judgment value and a LOW judgment value.

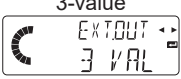
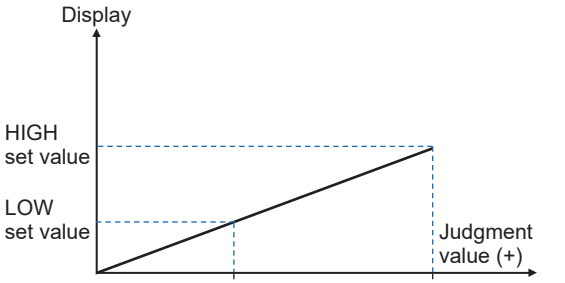
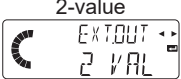
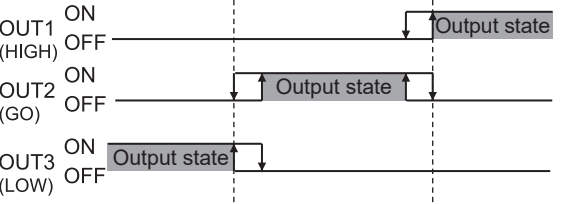
"Logic 2 (LOGIC2)" is output from the master unit as a judgment value (JUDGE.V) that indicates the output logic calculation result when slave units are connected.

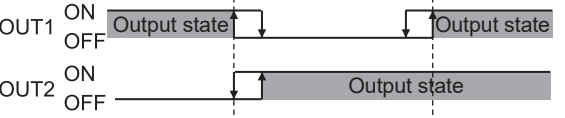
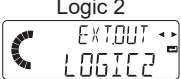
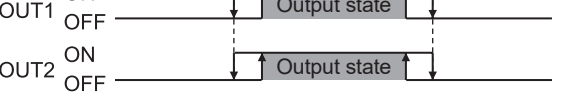
External output	Output operation			Display
	OUT1	OUT2	OUT3	
3-value 	HIGH	GO	LOW	
2-value 	Outside upper/ lower limit	GO	Alarm	
Logic 	Judgment 1	Judgment 2	Alarm	
Logic 2 	ALL GO (Connected controllers)	GO (Master unit)	Alarm (One of connected controllers)	

# FUNCTION SETTINGS

## <Operation of output 1/2/3 indicators when external output is set>

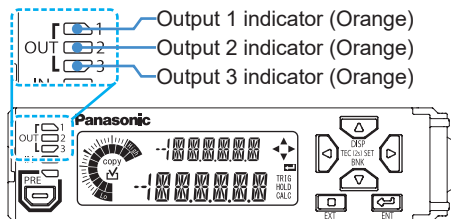

External output	Output operation	Output 1 indicator (Orange)	Output 2 indicator (Orange)	Output 3 indicator (Orange)
3-value	HIGH	Lights up	Turns OFF	Turns OFF
	GO	Turns OFF	Lights up	Turns OFF
	LOW	Turns OFF	Turns OFF	Lights up
2-value	Outside upper / lower limit	Lights up	Turns OFF	Turns OFF
	GO	Turns OFF	Lights up	Turns OFF
	Alarm	TurTurns OFFFF	Turns OFF	Lights up → Turns OFF (Note)
Logic	Judgment 1	Lights up	Turns OFF	Turns OFF
	Judgment 2	Turns OFF	Lights up	Turns OFF
	Alarm	Turns OFF	Turns OFF	Lights up → Turns OFF (Note)
Logic 2	ALL GO (Connected controllers)	Lights up	Turns OFF	Turns OFF
	GO (Master unit)	Turns OFF	Lights up	Turns OFF
	Alarm (One of connected controllers)	Turns OFF	Turns OFF	Lights up → Turns OFF (Note)

Note: The indicators are normally lit up, and turn off when an alarm occurs.

### <Reference>

- For controller I/O circuit diagrams, refer to “3-6-2 I/O Circuit Diagrams”.
- For the output operation settings, refer to “5-2-12 Output Operation (OUTPUT)”.
- For the alarm function, refer to “5-3-9 Alarm Setting (i)”.

## Setting method

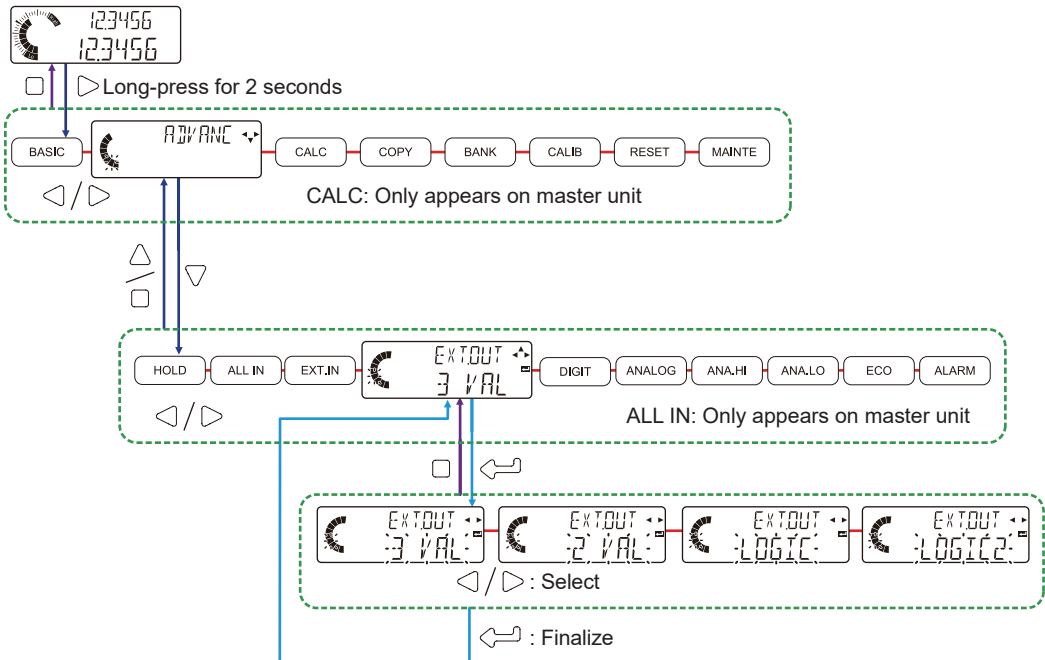

Setting item	Set values	Default value
External output (EXT.OUT)	3-value (3 VAL) 2-value (2 VAL) Logic (LOGIC) Logic 2 (LOGIC2)	3 VAL

# FUNCTION SETTINGS

## 5-3-5 Number of Digits Displayed (DIGIT)

You can change the number of digits that appear after the decimal point of the digital display.

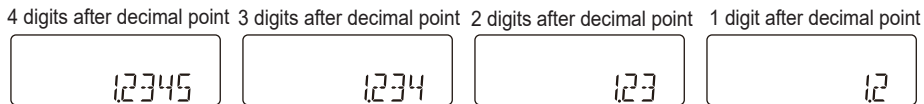

**<Reference>**  
Displayed digital numbers are right-aligned, regardless of the number of digits displayed setting.

### Setting method

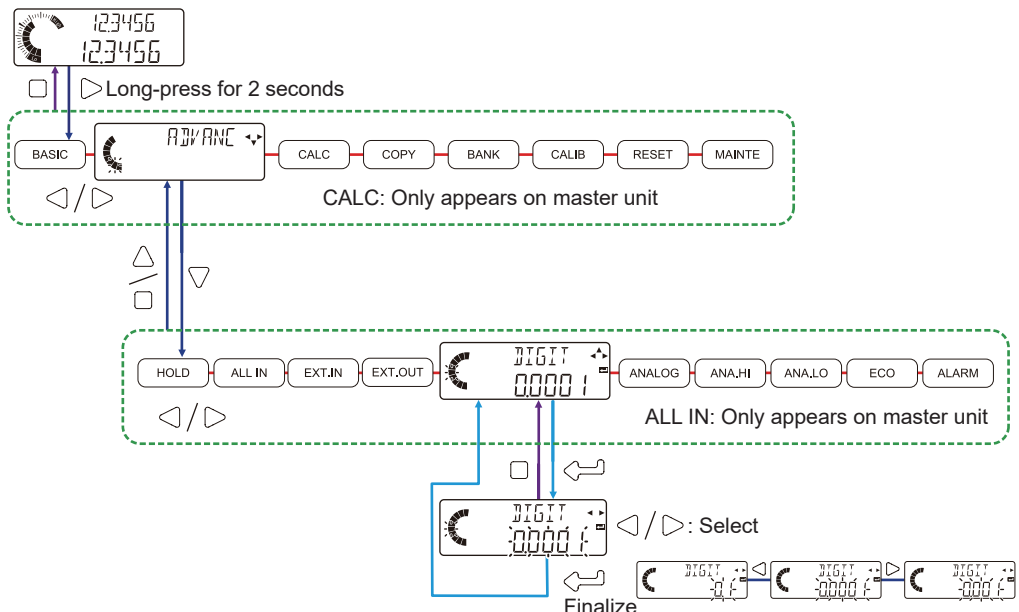

Setting item	Set values	Default value
Number of digits displayed (DIGIT)	4 digits (0.0001) 3 digits (0.001) 2 digits (0.01) 1 digit (0.1)	0.0001

**<Reference>**

- Changes to the number of digits displayed setting apply only to the display of normal measured values (NORM.V), LOW set value, HIGH set value, sensor head measured values, calculated values, and judgment values (JUDGE.V).
- Changes to the number of digits displayed setting do not affect judgment output.

## 5-3-6 Analog Scaling (ANALOG)

The judgment value (JUDGE.V) can be converted to a current (4 to 20mA) and output as analog output.

Analog scaling allows you to select the method of setting the scaling upper limit value and scaling lower limit value for analog output.

Analog scaling	Function
Default (DEFAULT)	Output an analog current according to the maximum stroke of the sensor head.
Free (FREE)	You can set the upper limit value and lower limit value of analog output. To set the upper limit value and lower limit value, refer to "5-3-7 Scaling Upper Limit Value / Scaling Lower Limit Value".

### ■ When default (DEFAULT) is set

The upper limit value varies by sensor head.

The lower limit value is "0.0000", regardless of the sensor head.

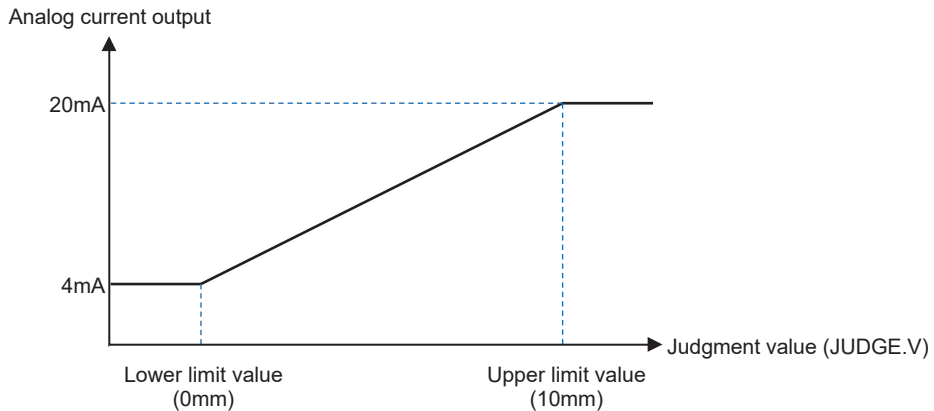

### ● Analog output specifications

Current output range	4 to 20mA
Resolution	0.3μA
Error output	0mA
Linearity	±0.25% F.S.
Maximum load impedance	250Ω max.

# FUNCTION SETTINGS

## Setting method

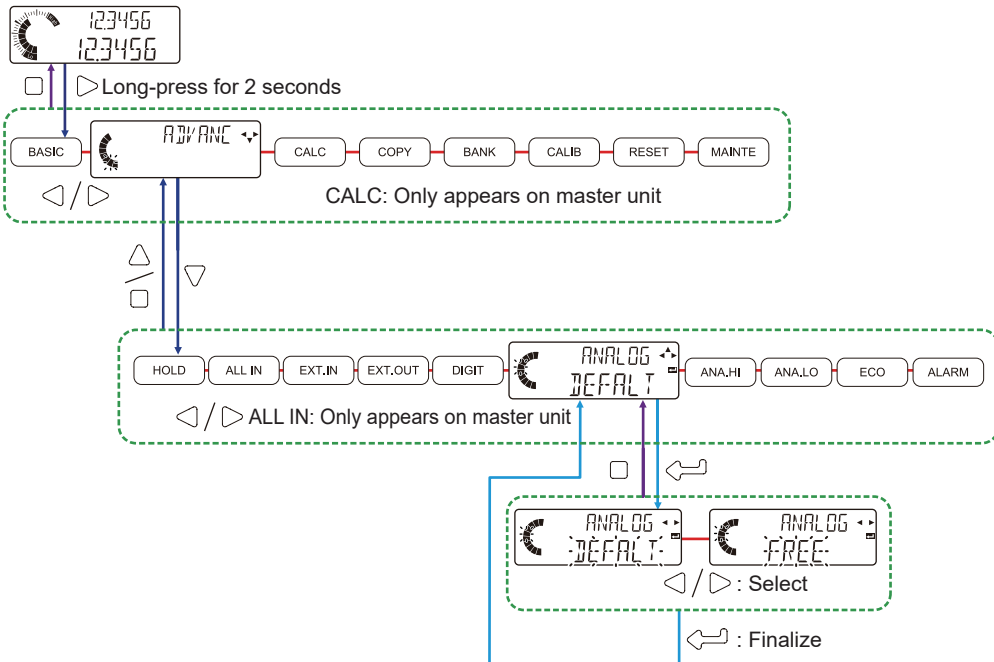

Setting item	Set values	Default value
Analog scaling (ANALOG)	Default (DEFAULT) Free (FREE)	DEFAULT

**5-3-7 Scaling Upper Limit Value / Scaling Lower Limit Value (ANAHI / ANALD)**

When analog scaling is set to “FREE”, you can set the upper limit value and lower limit value of scaling.

- **When scaling lower limit value < scaling upper limit value**

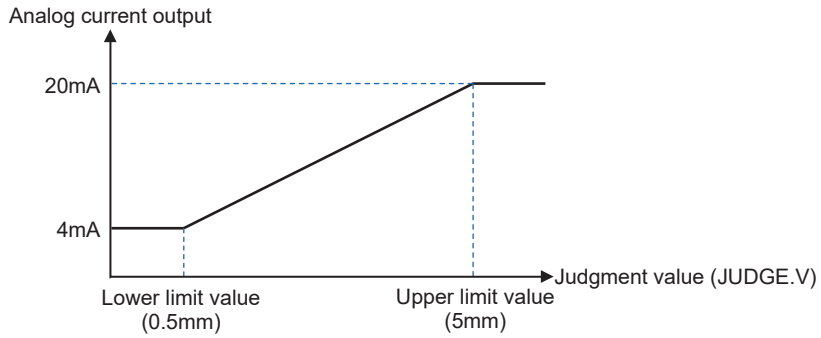

- **When scaling lower limit value > scaling upper limit value**

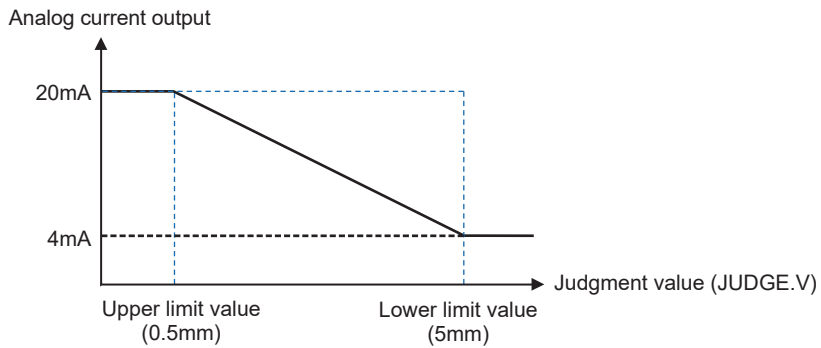

- **When scaling lower limit value = scaling upper limit value**

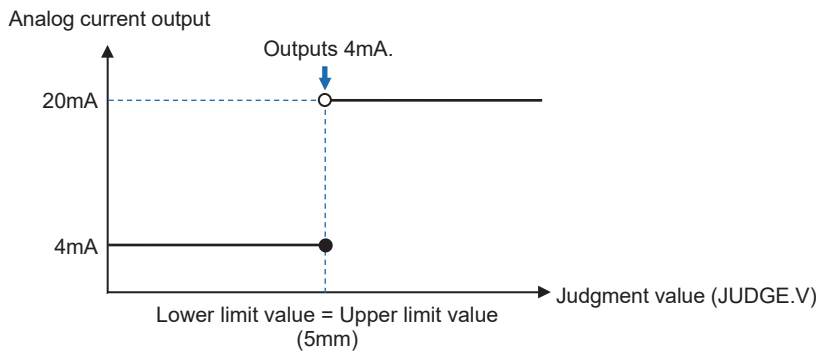

# FUNCTION SETTINGS

## Setting method

### • Scaling upper limit value setting

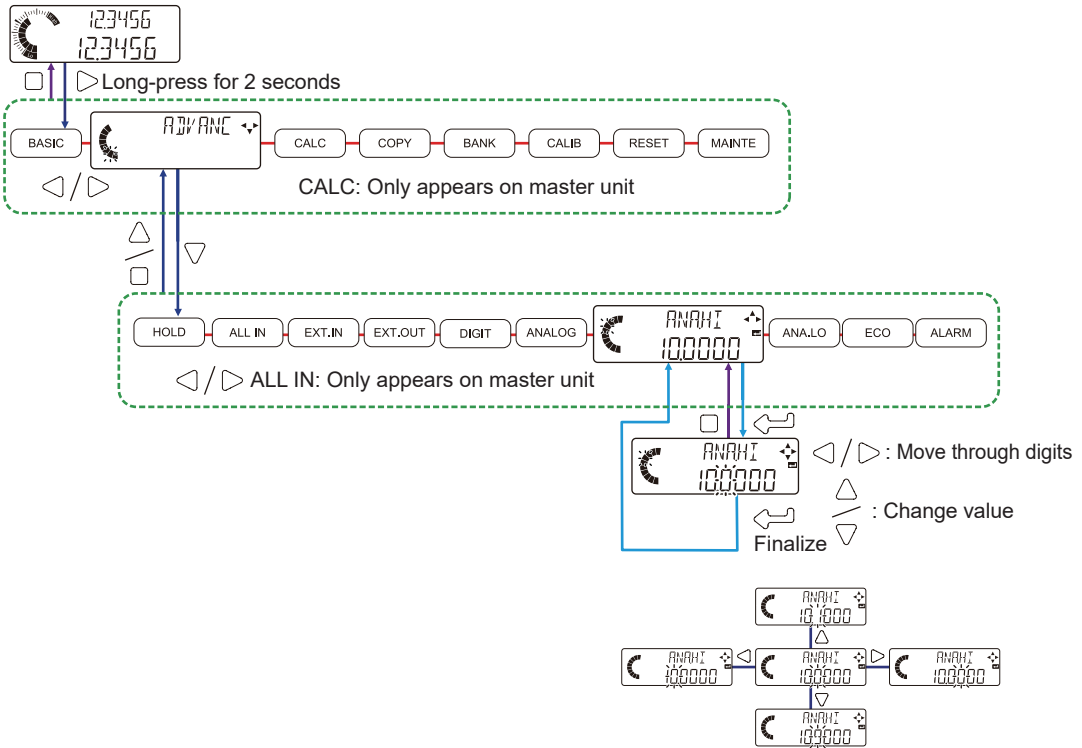

Setting item	Setting range	Default value
Scaling upper limit value (ANA.HI)	-199.9999 to 199.9999 (mm)	10.0000



## • Scaling lower limit value setting

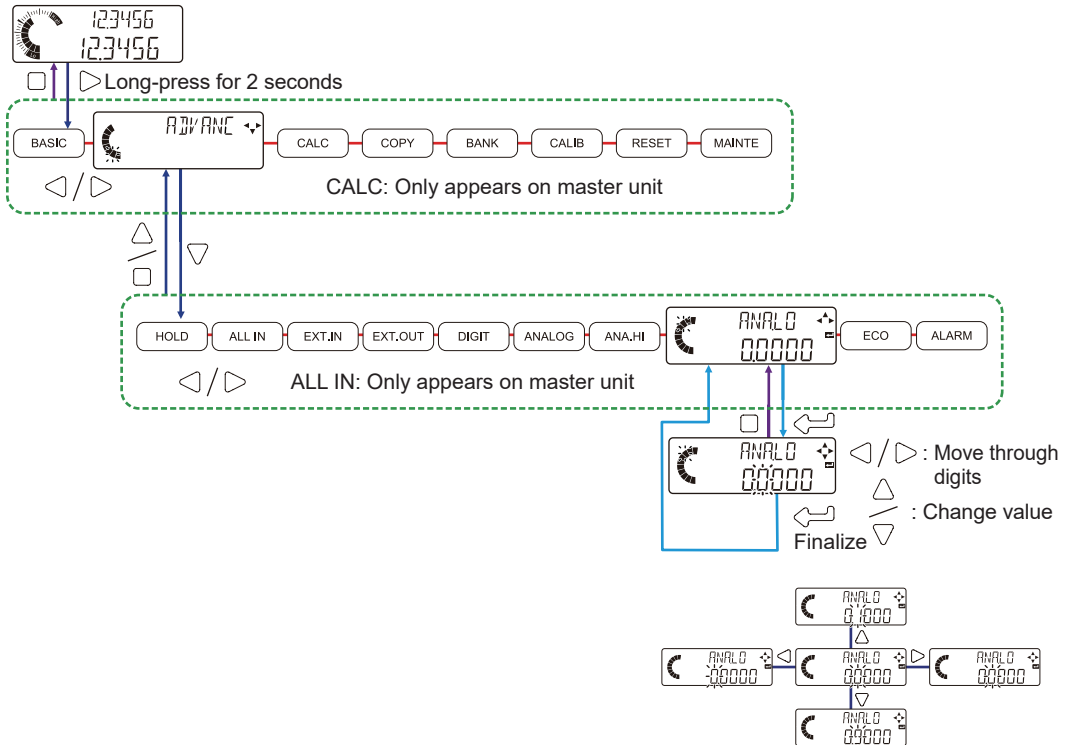

Setting item	Setting range	Default value
Scaling lower limit value (ANA.LO)	-199.9999 to 199.9999 (mm)	0.0000

# FUNCTION SETTINGS

## 5-3-8 Eco Mode (ECO)

You can save power by having the backlight of the controller display turn OFF when idle. When Eco mode is set to ON, the display backlight turns off 30 seconds after the last key operation is performed. When OFF, the backlight is turned ON by pressing any key.

### <Reference>

- If an error occurs when the backlight is OFF, the backlight turns ON.
- The backlight does not turn OFF while an error is displayed.

### Setting method

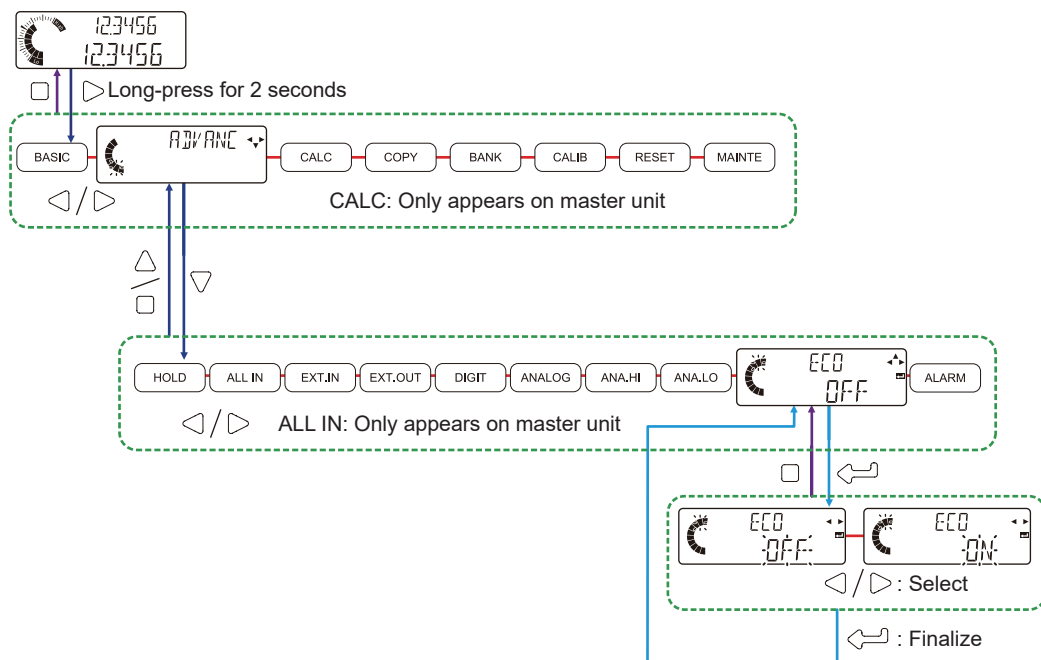

Setting item	Set values	Default value
Eco mode (ECO)	Eco OFF (OFF) Eco ON (ON)	OFF

### 5-3-9 Alarm Setting (ALARM)

You can set whether or not alarms are detected and the conditions for alarm detection.

- **Alarm setting items**

The alarm setting consists of the items below.

Alarm setting	Details
Alarm delay count	You can set the delay until an alarm is output when an error is detected.
Pressure check	You can turn pressure check ON / OFF. When set to ON, an alarm occurs when the pressure set value is exceeded.
Pressure check set value	Set the pressure check threshold value.
Catch check	You can turn catch check ON / OFF. The information checked varies depending on whether the type is regular or air-driven.
Number of connected controllers check	You can turn the number of connected controllers check ON / OFF.

## FUNCTION SETTINGS

### ■ Pressure Check / Pressure Check Set Value / Alarm Delay Count

If the spindle is pressed in too far, sensor head damage may result.  
By turning ON pressure check, an alarm is output to help prevent sensor head damage.

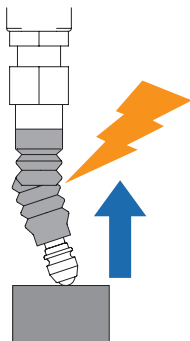

When the sensor head value exceeds the pressure check set check value, an alarm is output after sampling cycle (1ms) × alarm delay count time.  
By adjusting the alarm delay count, you can prevent alarm output due to instantaneous pressure changes.

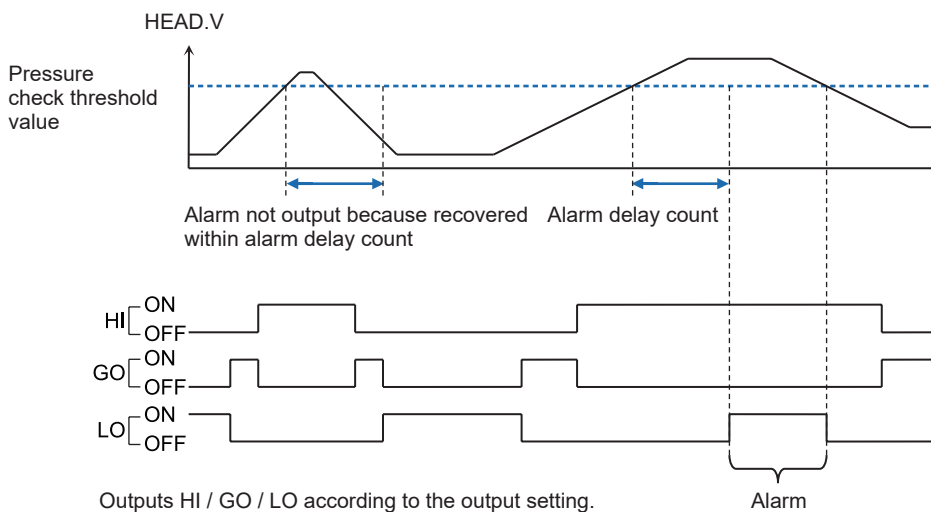

## Setting method

### • Alarm delay count

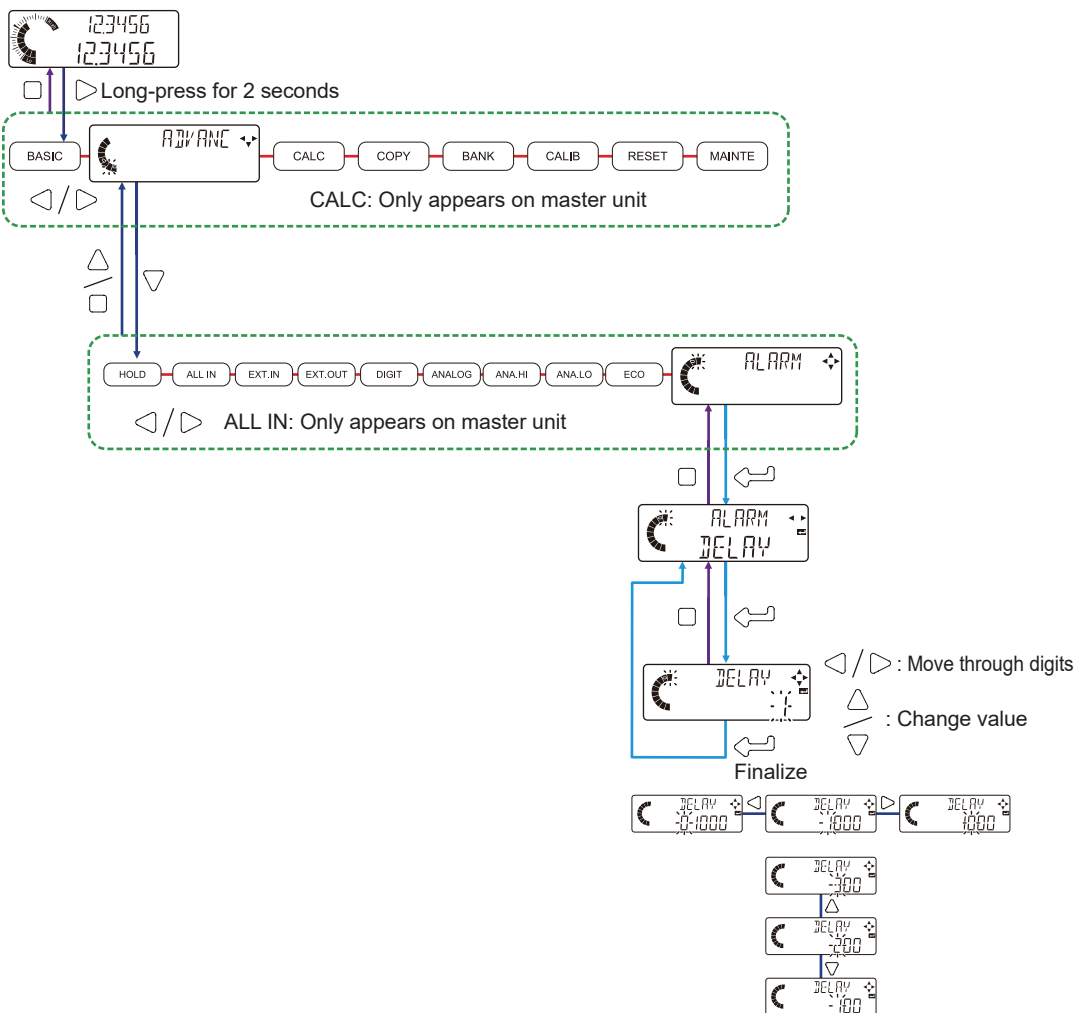

Setting item	Setting range	Default value
Alarm delay count (DELAY)	1 to 1000	1000

# FUNCTION SETTINGS

## • Pressure check

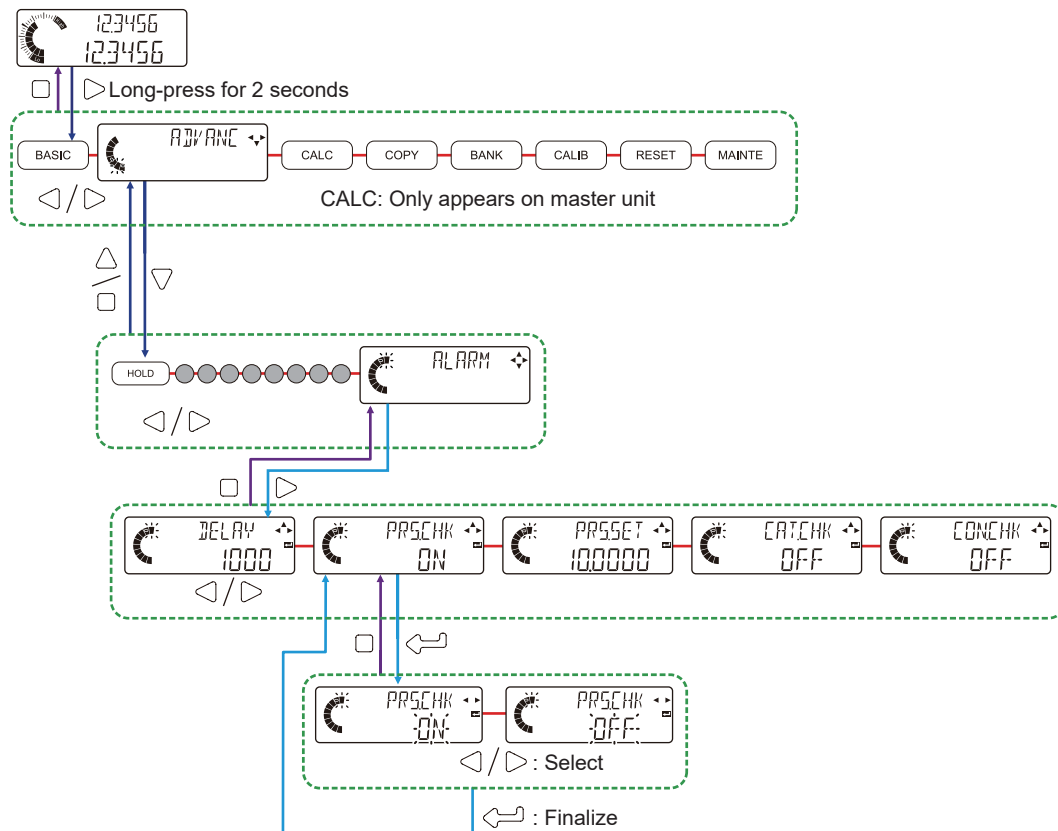

Setting item	Set values	Default value
Pressure check (PRS.CHK)	Check ON (ON) Check OFF (OFF)	Regular type: ON Air-driven type: OFF

### <Reference>

- When the controller is started by turning on the power, or the sensor head is reconnected, the pressure check default value is reset.
- To use an air-driven type sensor head, connect to an **HG-SC** series controller manufactured in February 2019 or later.

## • Pressure check set value

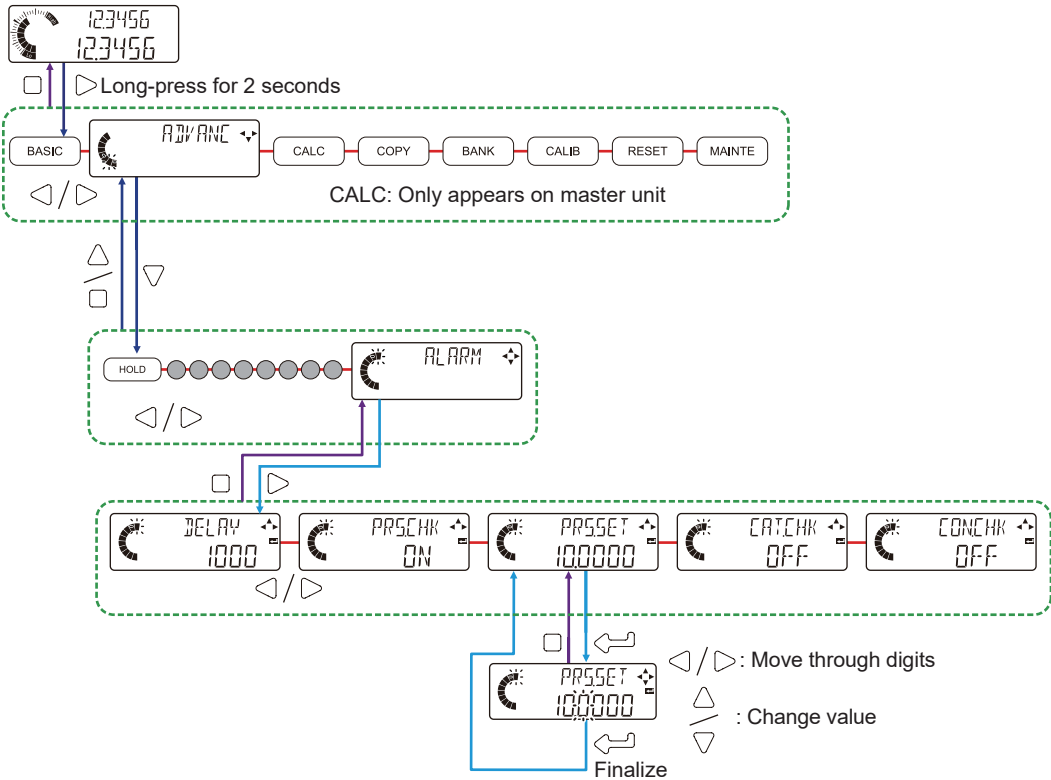

Setting item	Setting range	Default value
Pressure check set value (PRS.SET)	-199.9999 to 199.9999 (mm)	10mm type: 10.0000 32mm type: 32.0000 Air-driven type: 10.0000

### <Reference>

- If the setting has been changed from the default value, the pressure check set value will not change even if the connected sensor head type is changed.
- If the setting has not been changed from the default value, the pressure check set value is reset to match the type of sensor head connected.
- On an **HG-SC** series controller manufactured in January 2019 or earlier, the setting is not reset by simply connecting the sensor head. Always turn the power off and then on after connecting.
- To use an air-driven type sensor head, connect to an **HG-SC** series controller manufactured in February 2019 or later.

## FUNCTION SETTINGS

### ■ Catch Check

If the movement of the spindle worsens due to aging and the spindle does not return completely, accurate measurement will no longer be possible. This function detects failure of the spindle to return completely.

The information checked varies depending on whether the type is regular or air-driven.

#### <Regular type>

While the trigger input is ON, the function checks whether or not the spindle extends out fully [whether the normal measured value (NORM.V) is lower than the set LOW set value].

If the measured value never drops below the LOW set value while the trigger input is ON, an alarm occurs.

You can change the settings so that an alarm does not occur.

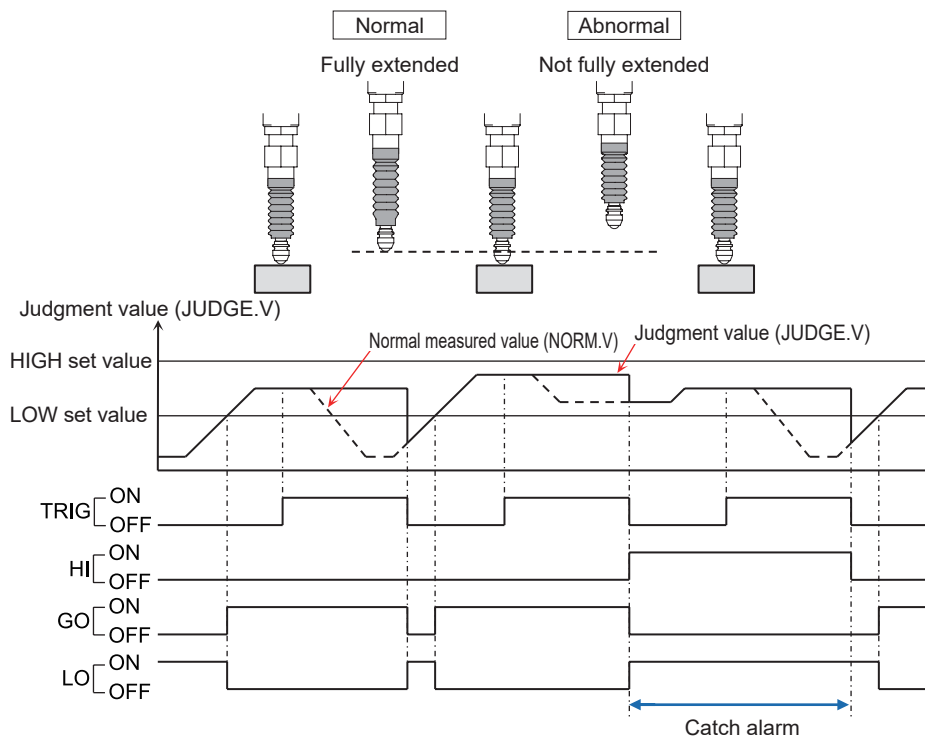

#### <Reference>

This function can only be used when the measurement mode is set to a mode that has external trigger input enabled in "5-3-1 Hold Setting (HOLD)".



## <Air-driven type>

While the trigger input is ON, this function checks if the spindle has retracted fully or [the normal measured value (NORM.V) is over the HIGH set value].

If the normal value does not exceed the HIGH set value even once while the trigger input is ON, an alarm occurs.

You can change the settings so that an alarm does not occur.

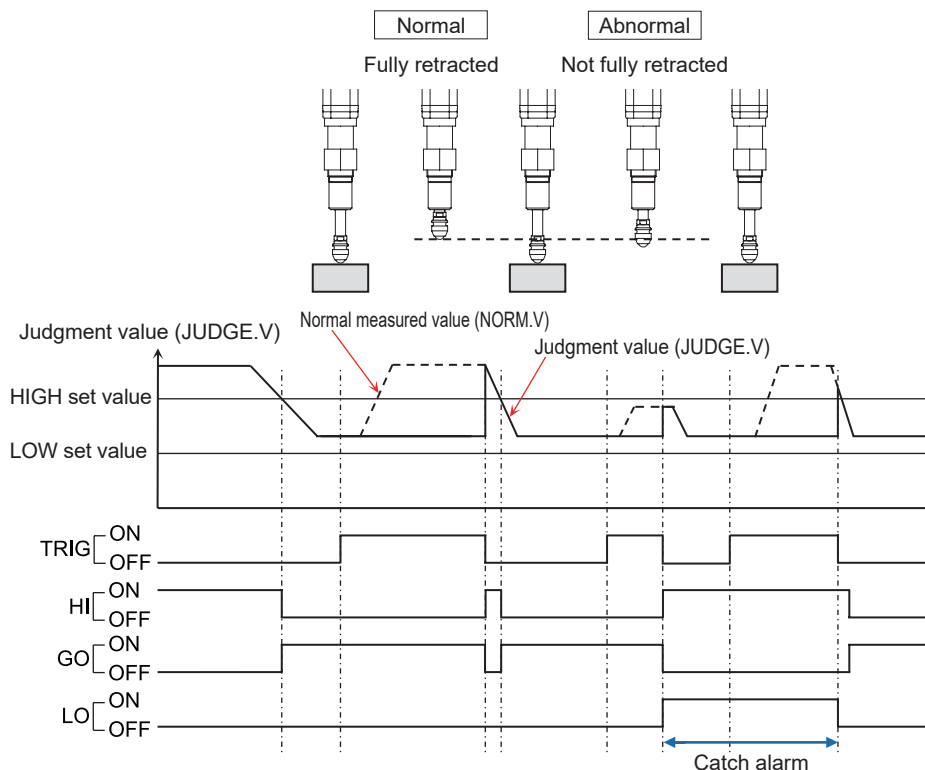

### <Reference>

This function can only be used when the measurement mode is set to a mode that has external trigger input enabled in "5-3-1 Hold Setting".



## ■ Number of Connected Controllers Check (Master Unit Only)

This function checks the number of controllers that are connected, and outputs an error if the number has changed.

An error occurs if the number of controllers increases or decreases as compared to the number of connected controllers at the time the check function was turned ON.

If you need to change the number of connected controllers, turn OFF the number of connected controllers check function, change the number of controllers, and then turn the check function back ON.

### Setting method

#### ● Number of connected controllers check

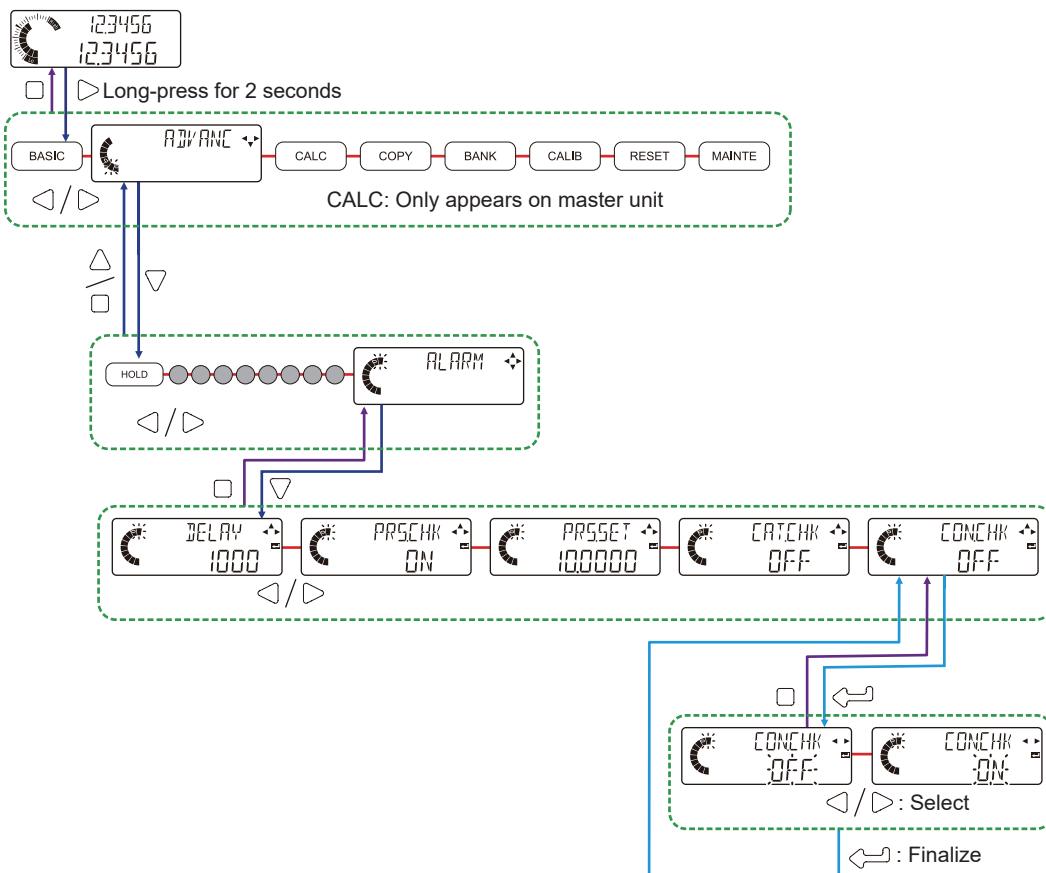

Setting item	Set values	Default value
Number of connected controllers check (CON.CHK)	Check OFF (OFF) Check ON (ON)	OFF

#### <Reference>

The number of connected controllers check can only be turned ON at the master unit.

# FUNCTION SETTINGS

## 5-4 Calculation Settings (CALC) (Master Unit Only)

- Structure of calculation settings menu

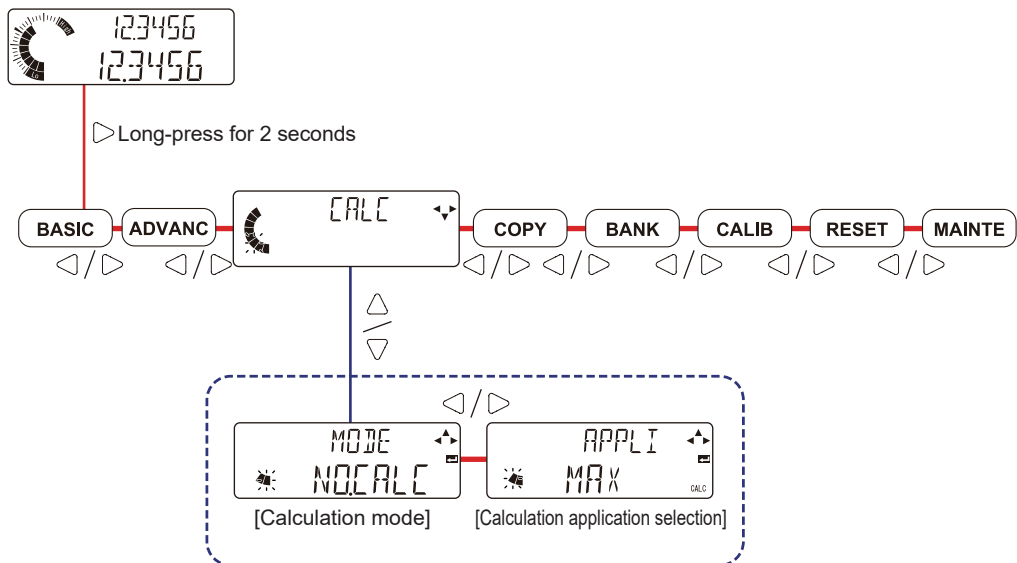

You can perform calculation processing based on the measured values of each of the connected controllers, and display the judgment result on the master unit's display or output the judgment result from the master unit.

### <Reference>

- A slave unit must be connected to the master unit when configuring the calculation settings. If a slave unit is not connected, "Calculation Mode" and "Calculation Application Selection" will not appear.
- The calculation setting menu only appears on the master unit.

## 5-4-1 Calculation Mode (MODE)

Use calculation mode to set whether or not calculation is performed.

Calculation mode	Function
No calculation (NOCALC)	The master unit and each connected slave unit operate individually without performing calculation.
Calculate (CALC)	You can perform calculation on the measured values of the master unit and each of the connected slave units using the selected application, and display the judgment result on the master unit's display or output the judgment result from the master unit.

### Setting method

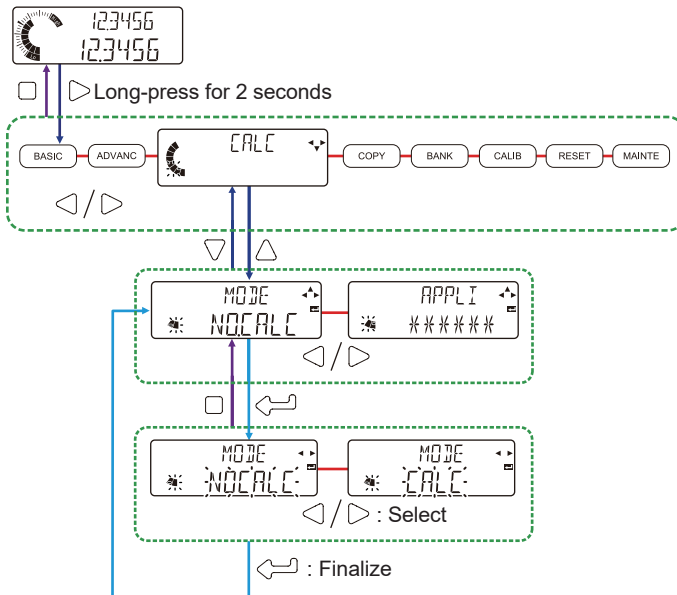

Setting item	Set values	Default value
Calculation mode (MODE)	No calculation (NO.CALC) Calculate (CALC)	NO.CALC

## FUNCTION SETTINGS

### 5-4-2 Calculation Application Selection (APPL I)

When calculation mode is set to "CALC", the calculation application selection setting can be configured.

This setting lets you select the application that is used for calculation.

The function of each application is shown below.

Application	Function	Number of slave units
Maximum value (MAX)	Determines the maximum value of the measured values of the connected controllers.	1 unit or more
Minimum value (MIN)	Determines the minimum value of the measured values of the connected controllers.	1 unit or more
Flatness (FLAT)	Extracts the maximum value and the minimum value from the measured values of the connected controllers, and subtracts the minimum value from the maximum value. [Calculated value] = [Max. value] - [Min. value]	1 unit or more
Average value (AVERAG)	Sums the measured values of the connected controllers and divides the result by the number of controllers. [Calculated value] = ([Master unit] + [Slave unit 1] + ... + [Slave unit n]) ÷ (1+n)	1 unit or more
Standard difference (STAND)	This calculation is performed on the measured value of a connected slave unit and the master unit. The measured value of the master unit is subtracted from the measured value of the slave unit. The result is output from the slave unit. [Calculated value] = [Slave unit n] - [Master unit]	1 unit or more
Torsion (TORSIN)	Measures four locations and calculates the amount of torsion. The result is the calculated value. [Calculated value] = ([Master unit] - [Slave unit 1] - [Slave unit 3] - [Slave unit 2])	3 units
Curvature (CURVEA)	Measures three locations and calculates the amount of curvature. The result is the calculated value. [Calculated value] = ([Master unit] + [Slave unit 2]) ÷ 2 - [Slave unit 1]	2 units
Thickness (THICK)	The measured object is pressed from above and below by the master unit and a slave unit, and the measured values of the master unit and slave unit are summed. [Calculated value] = [Master unit] + [Slave unit 1]	1 unit

The CALC status mark lights on a controller that is performing calculation.



#### <Reference>

If more than the specified number of slave units are connected when "TORSIN" (torsion), "CURVEA" (curvature), or "THICK" (thickness) is selected, the specified number of slave units closest to the master unit will be used for calculation.

Slave units other than those units will not be used.

## Setting method

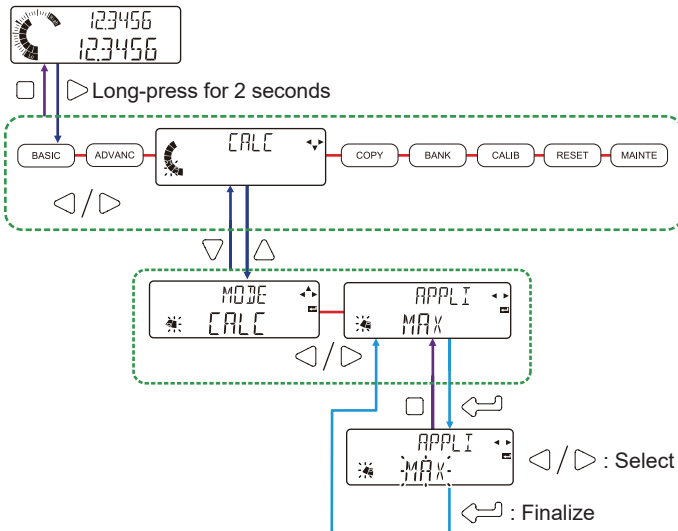

Setting item	Set values	Default value
Application (APPLI)	Maximum value (MAX) Minimum value (MIN) Flatness (FLAT) Average value (AVERAG) Standard difference (STAND) Torsion (TORSIN) Curvature (CURVEA) Thickness (THICK)	MAX

## ■ Maximum Value (MAX)

This application determines the largest measured value of the master unit and slave units.

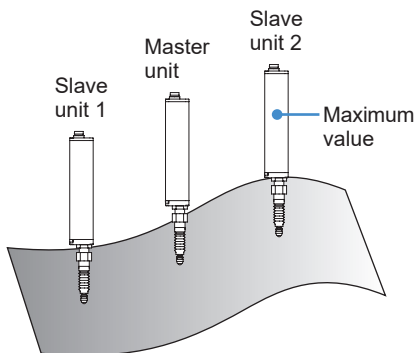

Measured value of "slave unit 2" is maximum value and becomes calculated value of master unit.

- None of the connected slave units output the judgment result. (Always OFF)
- All sensor head indicators show the judgment result of the master unit.
- The response time for judgment output is the response time setting on the master unit and slave units plus 3ms.
- The judgment value (JUDGE.V) (calculation result) appears on the digital display / MAIN (white) of the master unit. The normal measured value (NORM.V) appears on the digital display / MAIN (white) of each slave unit.

## FUNCTION SETTINGS

### ■ Minimum Value (MIN)

This application determines the smallest measured value of the master unit and slave units.

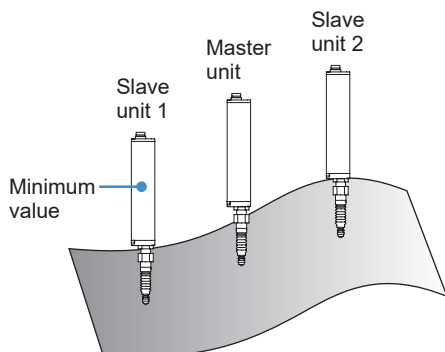

Measured value of "slave unit 1" is minimum value and is taken as calculated value of master unit.

- None of the connected slave units output the judgment result. (Always OFF)
- All sensor head indicators show the calculation result of the master unit.
- The response time for judgment output is the response time setting on the master unit and slave units plus 3ms.

### ■ Flatness (FLAT)

This application extracts the largest measured value and smallest measured value of the master unit and slave units, and calculates the difference (maximum value - minimum value).

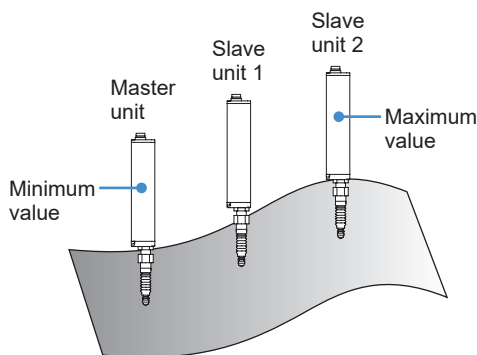

Maximum value (Measured value of "slave unit 2") - Minimum value (Measured value of "master unit") is calculated value of master unit.

- None of the connected slave units output the judgment result. (Always OFF)
- All sensor head indicators show the judgment result of the master unit.
- The response time for judgment output is the response time setting on the master unit and slave units plus 3ms.



## ■ Average Value (AVERAGE)

This application calculates the average value of the measured values of the master unit and slave units.

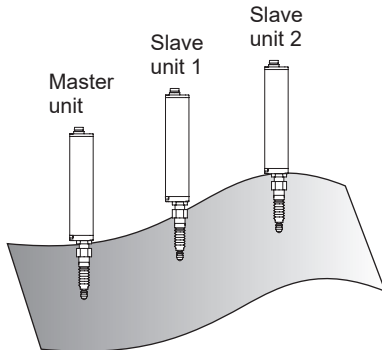

$$\frac{([\text{Master unit}] + [\text{Slave unit 1}] + \dots + [\text{Slave unit n}])}{(1+n)}$$
 is calculated value of master unit.  
"n" is the number of slave units

- None of the connected slave units output the judgment result. (Always OFF)
- All sensor head indicators show the judgment result of the master unit.
- The response time for judgment output is the response time setting on the master unit and slave units plus 3ms.

## ■ Standard Difference (STANDARD)

This application calculates the difference between the measured value of each slave unit and the master unit.

With this application, each slave unit outputs the judgment result.

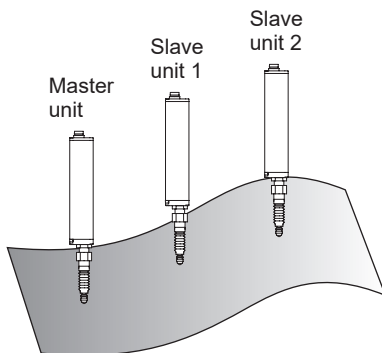

$$(\text{Measured value of "slave unit 2"} - \text{Measured value of "master unit"})$$
 is calculated value of master unit.

- The master unit performs judgment as a separate unit that does not perform calculation.
- The hold function cannot be used on the master unit.
- The response time for judgment output is the response time setting on the master unit and slave units plus 3ms.

## FUNCTION SETTINGS

### ■ Torsion (TORSIN)

This function calculates the torsion from measured values at four locations on the measured object.

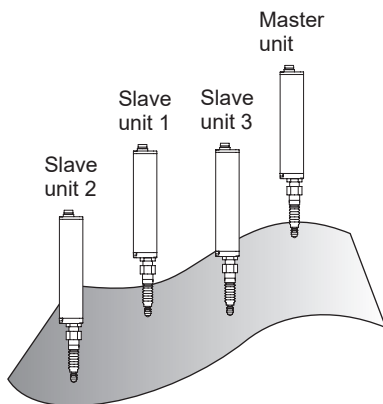

$$\text{Calculated value} = (\text{Measured value of master unit} - \text{Measured value of slave unit 1}) \\ - (\text{Measured value of slave unit 3} - \text{Measured value of slave unit 2})$$

- The three slave units closest to the master unit do not output a judgment result. (Always OFF) If four or more slave units are connected, the 4th and subsequent slave units perform normal judgment without calculation.
- The sensor head indicators of the three slave units closest to the master unit show the judgment result of the master unit.
- The response time for judgment output from the master unit is the response time setting on the master unit and slave units plus 3ms.

#### <Reference>

This application can only be selected when at least three slave units are connected.

### ■ Curvature (CURVER)

This function calculates the curvature from measured values at three locations on the measured object.

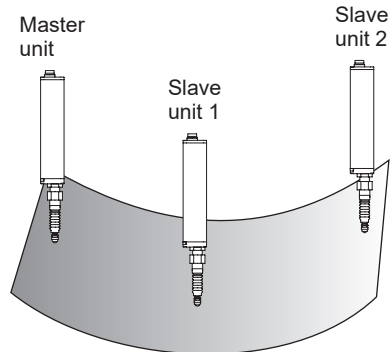

$$\text{Calculated value} = (\text{Measured value of master unit} + \text{Measured value of slave unit 2}) \div 2 - \text{Measured value of slave unit 1}$$

- The two slave units closest to the master unit do not output a judgment result. (Always OFF)  
If three or more slave units are connected, the 3rd and subsequent slave units perform normal judgment without calculation.
- The sensor head indicators of the two slave units closest to the master unit show the judgment result of the master unit.
- The response time for judgment output from the master unit is the response time setting on the master unit and slave units plus 3ms.

#### <Reference>

This application can only be selected when at least two slave units are connected.

## FUNCTION SETTINGS

---

### ■ hickness (*THICK*)

This function calculates thickness by pressing on both sides of the measured object with two sensor heads.

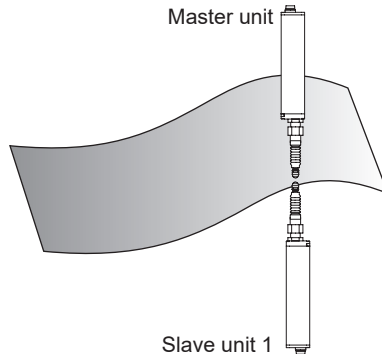

Calculated value = Measured value of master unit + Measured value of slave unit 1

- The slave unit closest to the master unit does not output a judgment result. (Always OFF) If two or more slave units are connected, the 2nd and subsequent slave units perform normal judgment without calculation.
- The sensor head indicator of the slave unit closest to the master unit shows the judgment result of the master unit.
- The response time for judgment output from the master unit is the response time setting on the master unit and slave units plus 3ms.

#### <Reference>

This application can only be selected when at least one slave unit is connected.

5-5 Copy Settings (COPY)

• Structure of copy settings menu

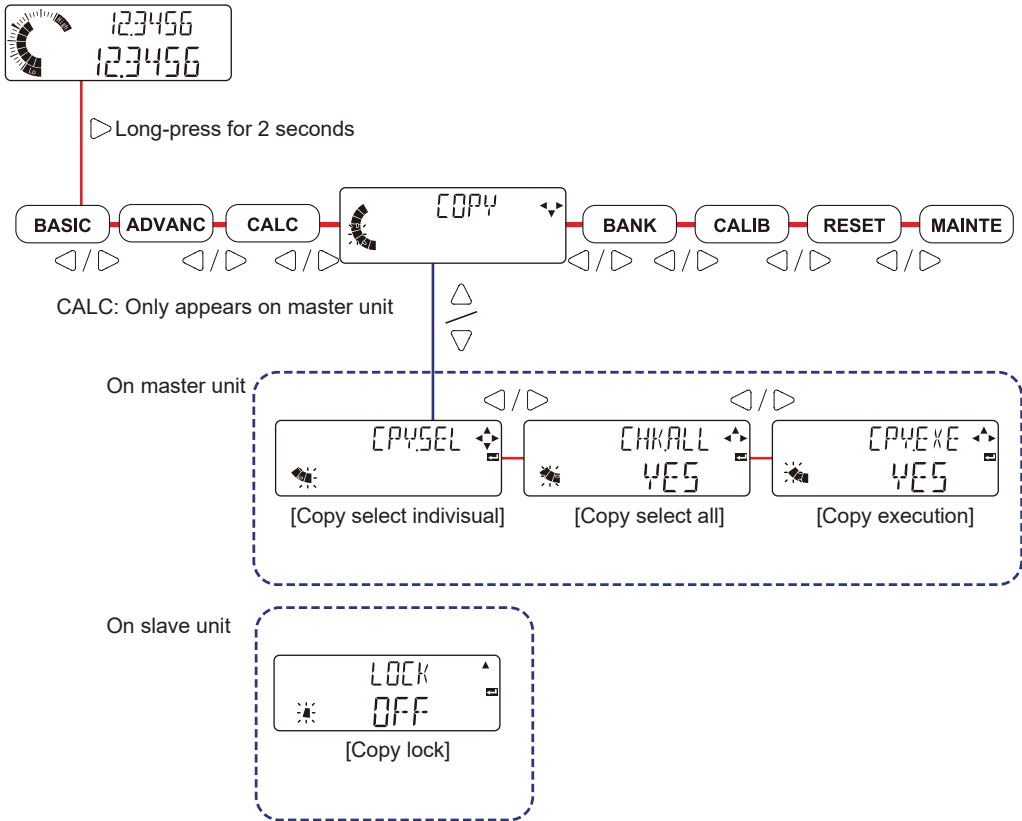

## FUNCTION SETTINGS

The settings on the master unit can be copied to slave units connected to the master unit.

You can select individual settings to be copied from the master unit to the slave units. You can also copy all settings at once.

When "CPY.EXE" is set to "YES" on the master unit, copying is executed when you press the ENTER key.

The slave units have a function that prevents copying from the master unit.

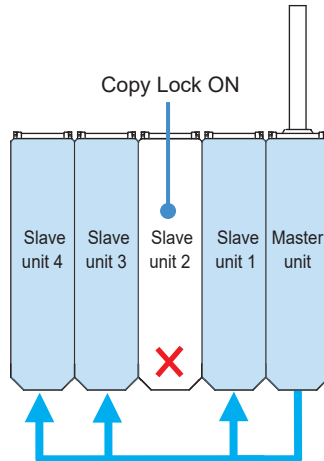

### <Reference>

Only current settings can be copied. Settings stored in a bank are not copied.

## 5-5-1 Copy select individual (CPYSEL) (Master Unit Only)

You can copy selected individual settings from the master unit to the slave unit.

### • Settings copied

Settings	Item
Basic settings (BASIC)	HIGH set value (HI.SET)
	LOW set value (LO.SET)
	Hysteresis (HYSTER)
	Teaching type (TEACH)
	Tolerance <±> (TOL<±>)
	Preset value (PR. VAL)
	Preset data selection (PR.OBJ)
	Preset save (PR.SAVE)
	Measurement direction (DIRECT)
	Lever ratio (LEVER)
	Response time (SPEED)
	Output operation (OUTPUT)
Advanced settings (ADVANC)	Hold setting (HOLD)
	External input (EXT.IN)
	External output (EXT.OUT)
	Number of digits displayed (DIGIT)
	Eco mode (ECO)
	Alarm setting (ALARM)

### • Indication of settings to be copied

Settings selected for copying are indicated by a checkmark in the basic settings (BASIC) screen and advanced settings (ADVANC) screen.

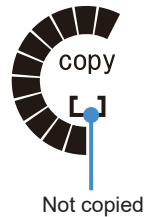

#### <Reference>

- By executing select all, you can copy all settings at once.
- You can use preset keys to select individual settings to be copied / not copied in the basic settings (BASIC) and advanced settings (ADVANC).

# FUNCTION SETTINGS

## Setting method

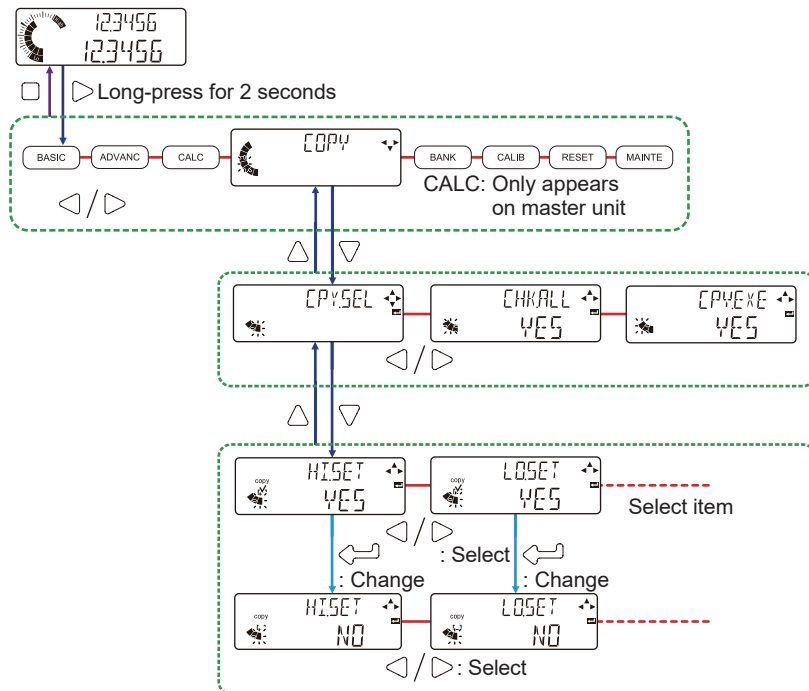

Setting item	Set values	Default value
Copy select individual (CPY.SEL)	HIGH set value (HI.SET): YES / NO	YES
	LOW set value (LO.SET): YES / NO	YES
	Hysteresis (HYSTER): YES / NO	YES
	Teaching type (TEACH): YES / NO	YES
	Tolerance ( $\pm$ ) (TOL< $\pm$ >): YES / NO	YES
	Preset value (PR. VAL): YES / NO	YES
	Preset data selection (PR.OBJ): YES / NO	YES
	Preset save (PR.SAVE): YES / NO	YES
	Measurement direction (DIRECT): YES / NO	YES
	Lever ratio (LEVER): YES / NO	YES
	Response time (SPEED): YES / NO	YES
	Output operation (OUTPUT): YES / NO	YES
	Hold setting (HOLD): YES / NO	YES
	External input (EXT.IN): YES / NO	YES
	External output (EXT.OUT): YES / NO	YES
	Number of digits displayed (DIGIT): YES / NO	YES
Eco mode (ECO): YES / NO	YES	
Alarm setting (ALARM): YES / NO	YES	



## 5-5-2 Copy Select All (CHKALL) (Master Unit Only)

You can select all settings for copying.

### <Reference>

Even if "NO" (do not execute) is selected in copy select individual, an item selected for copying will not be excluded from copying.

### Setting method

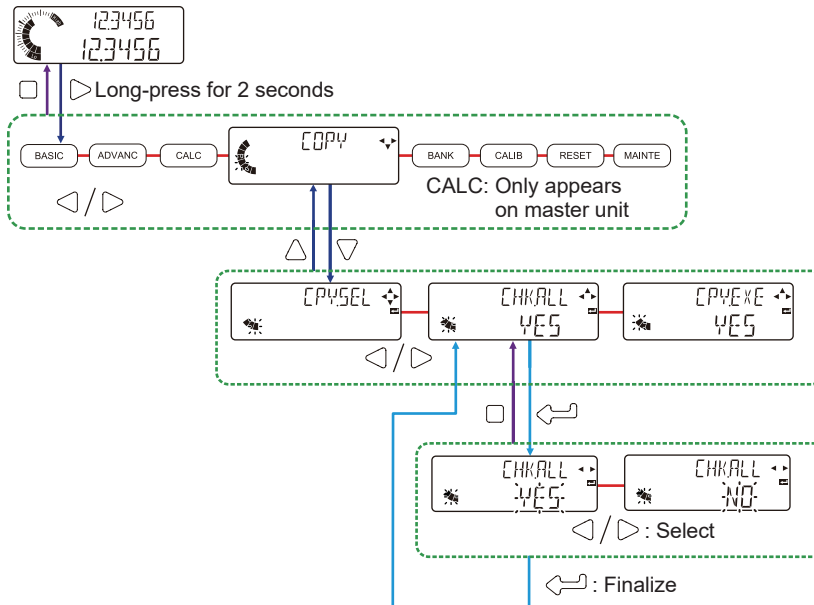

Setting item	Set values	Default value
Copy select all (CHK.ALL)	Copy all (YES) Do not copy all (NO)	YES

# FUNCTION SETTINGS

## 5-5-3 Copy Execution (CPY.EXE) (Master Unit Only)

You can execute copying of individually selected settings or all settings from the master unit to the slave units.

### Setting method

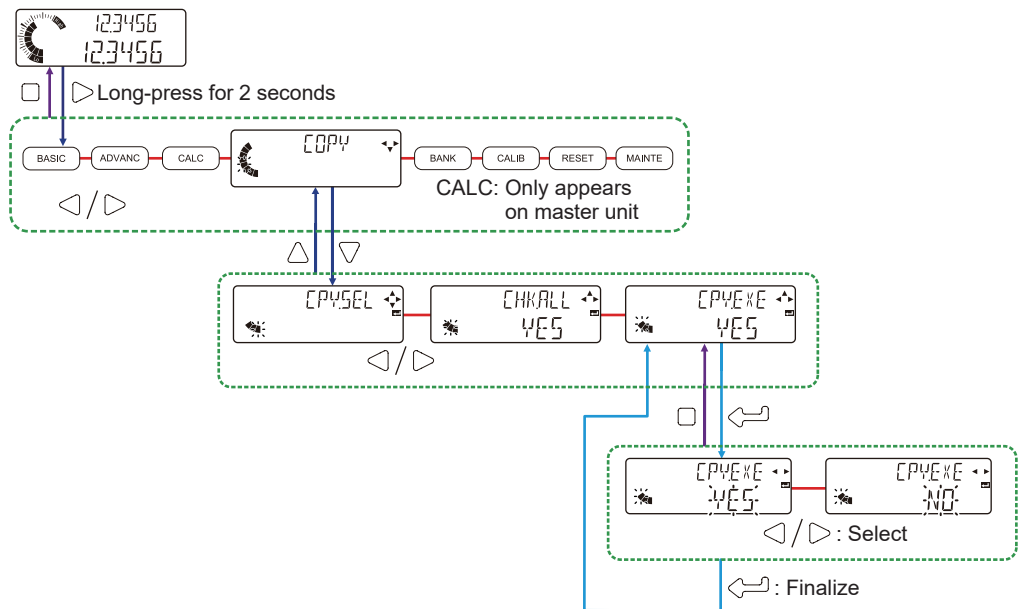

Setting item	Set values	Default value
Copy execution (CPY.EXE)	Execute (YES) Do not execute (NO)	YES

### <Reference>

When copying is executed, "NOW" appears in the digital display / SUB (green), and "COPY" appears in the digital display / MAIN (white).

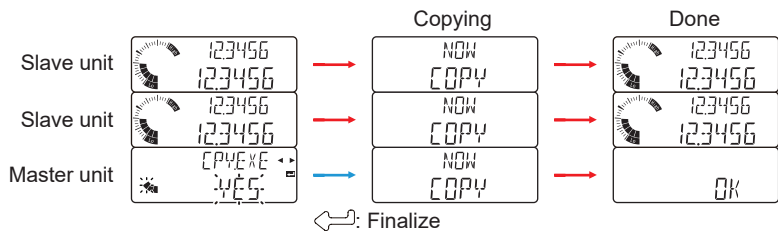

## 5-5-4 Copy Lock (LOCK) (Slave Units Only)

Copy lock can only be set on slave units.

By setting copy lock on a slave unit, you can prohibit copying from the master unit.

### Setting method

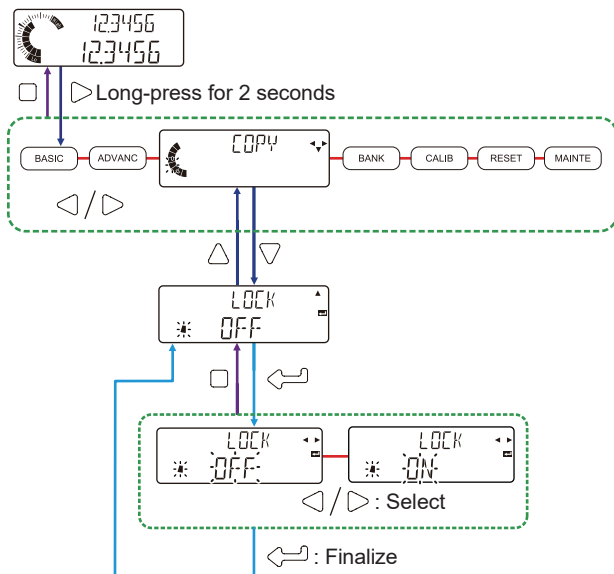

Setting item	Set values	Default value
Copy lock (LOCK)	Copy Lock OFF (OFF) Copy Lock ON (ON)	OFF

### <Reference>

When copy lock is set on a slave unit, "COPY" appears in the digital display / SUB (green) during copying, and "LOCK" appears in the digital display / MAIN (white).

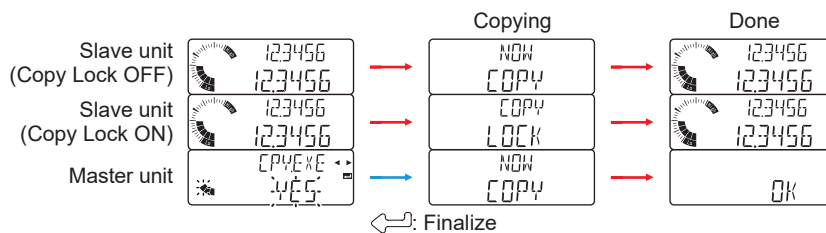

# FUNCTION SETTINGS

## 5-6 Bank Settings (BANK)

### • Structure of bank settings menu

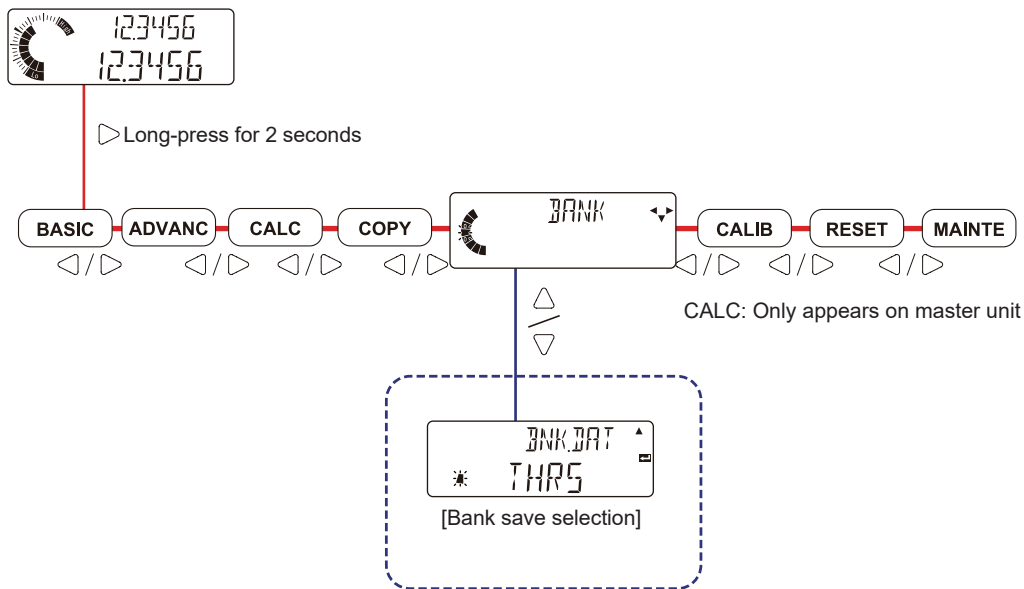

### 5-6-1 Bank Save Setting (BANK.DAT)

You can select the settings in a bank that are saved or loaded with the bank save setting.

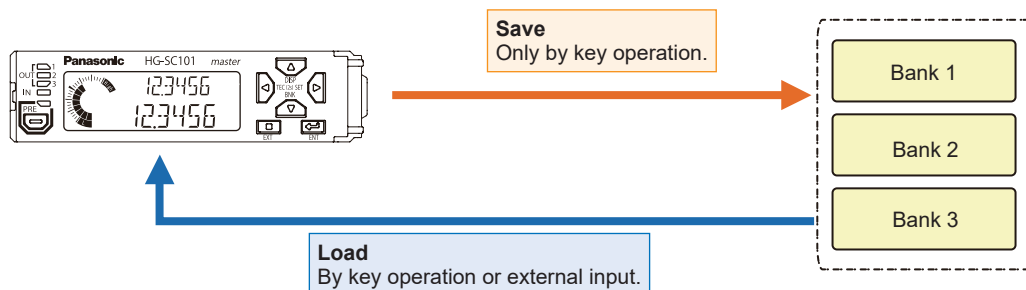

Bank save	Function
HIGH set value, LOW set value (THRS)	Select the HIGH set value and LOW set value.
HIGH set value, LOW set value, preset value (THRS.PR)	Select the HIGH set value, LOW set value, and preset value
All (ALL)	Select all settings.

#### <Reference>

- Settings loaded from a bank are saved even if the power is turned OFF.
- For the procedures for saving and loading settings, refer to “4-2-4 Bank Mode”.

## Setting method

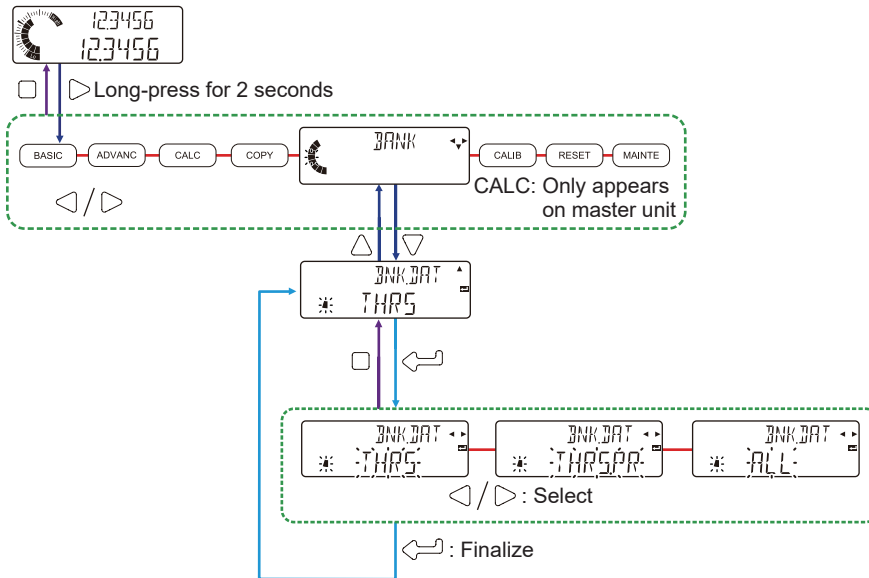

Setting item	Set values	Default value
Bank save setting (BNK.DAT)	HIGH set value, LOW set value (THRS) HIGH set value, LOW set value, preset value (THRS.PR) All (ALL)	THRS

# FUNCTION SETTINGS

## 5-7 Calibration Settings (CALIB)

### • Structure of calibration setting menu

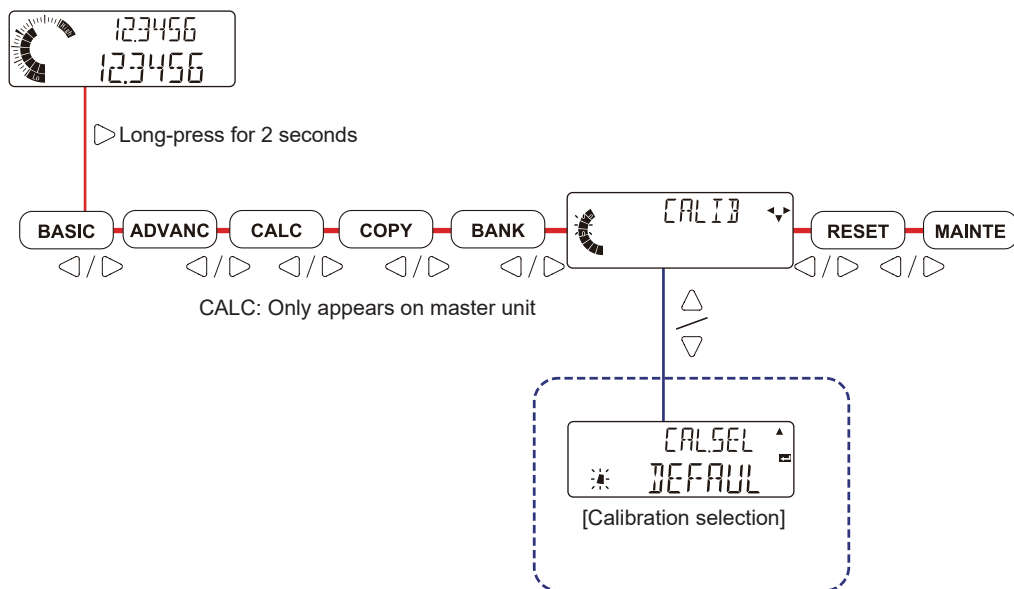

### 5-7-1 Calibration Selection (CALSEL)

You can perform zero-point adjustment and span adjustment when a sensor head is replaced to reduce installation error.

Calibration settings	Set values	Function
Calibration selection (CAL.SEL)	Default (DEFAULT)	Set to the factory default state.
	User settings (USER)	Execute calibration using the preset values below, and correct the zero point and span.
	Acquired value 1 (CL.SET1)	Move the spindle to the zero point for calibration and acquire the measured value.
	Acquired value 2 (CL.SET2)	Move the spindle to the target point for span adjustment and acquire the measured value.
	Adjustment value 2 (AJ.VAL2)	Enter a number for the target value.

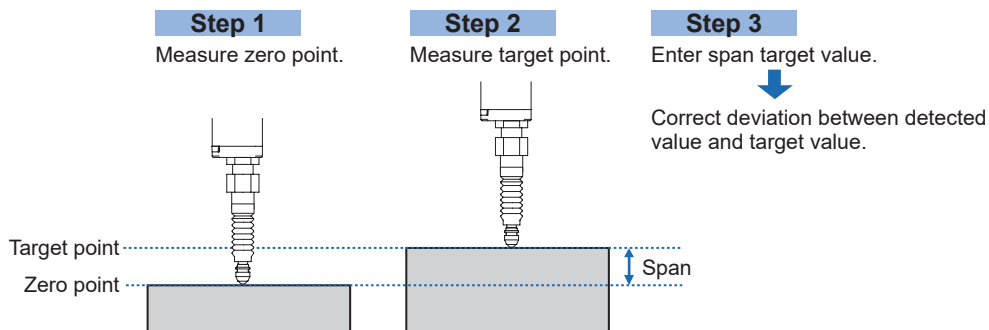

## <Reference>

- In the following cases, calibration cannot be executed. "ERROR" appears in the digital display / MAIN (white).
  - No magnitude correlation between the target value and detected value (the signs of the target value and detected value do not match).
  - The adjustment factor that resulted from span adjustment was over twice the factory default span.
  - The measured value is indeterminate ("-----" appears).
  - The measured value is outside the measurement range ("+OVER" or "-OVER" appears).

## Setting method

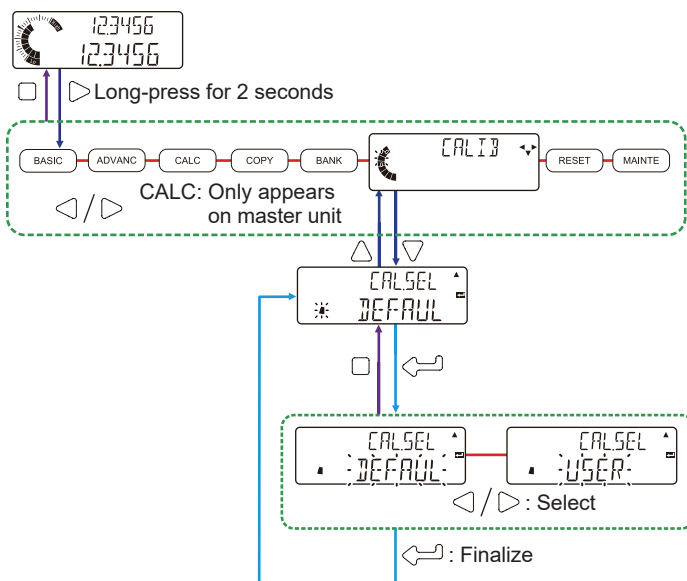

Setting item	Set values	Default value
Calibration selection (CAL.SEL)	Default (DEFAULT) User settings (USER)	DEFAULT

## FUNCTION SETTINGS

- When set to user settings (USER)

1. When set to “USER”, move the spindle to the zero point position and press the ENTER key.

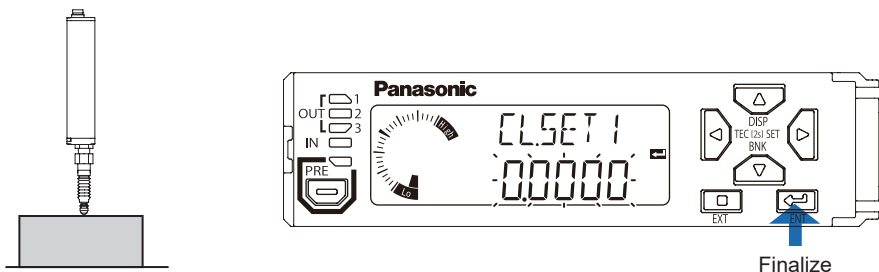

2. Move the spindle to the target point position and press the ENTER key.

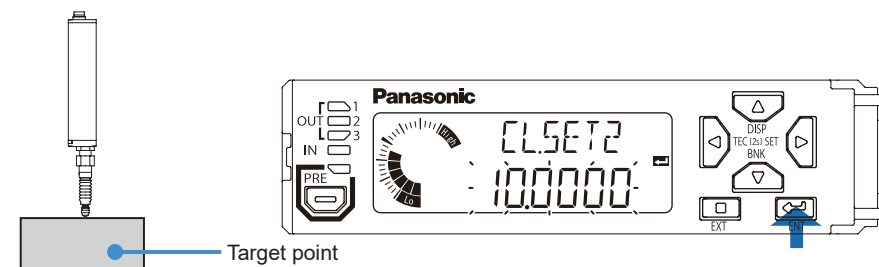

3. Enter the target value by using the LEFT / RIGHT key (◀ / ▶) to move through digits and the UP / DOWN key (▲ / ▼) to change values.

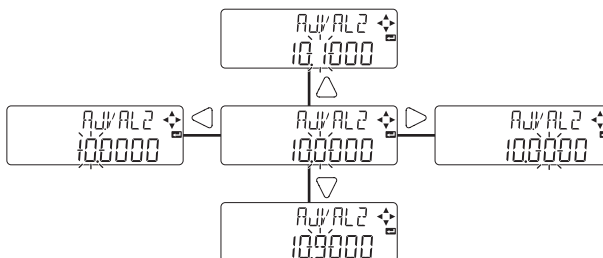

Setting item		Set values	Default value
User settings (USER)	Adjustment value 2 (AJ.VAL2)	-199.9999 to 199.9999 (mm)	10.0000



- 4.** Press the ENTER key.  
When the zero point measured value and target point measured value have been correctly acquired, "GOOD" appears and calibration is executed.



- 5.** Press the EXIT key repeatedly to return to the base screen.

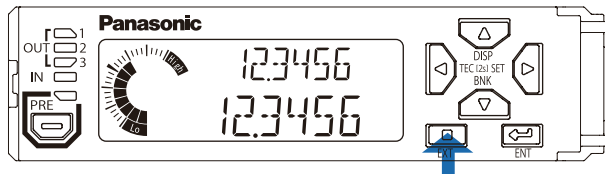

# FUNCTION SETTINGS

## 5-8 Initialization (RESET)

### • Structure of initialization menu

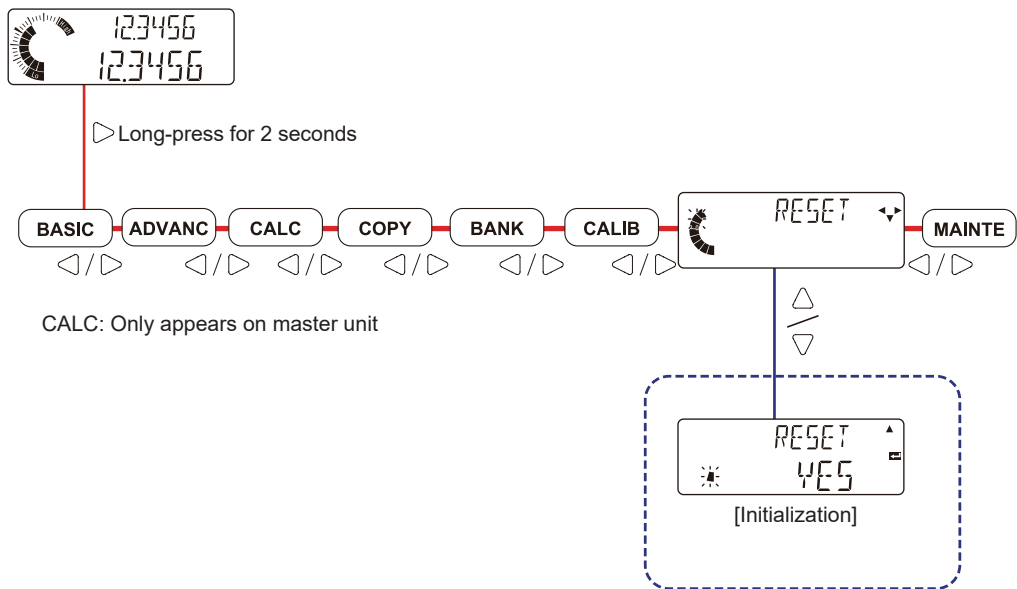

You can return all controller settings to the factory default state.  
For the default value of each setting, refer to “5-1-3 Setting Items and Default Values”.

#### <Reference>

- Executing initialization does not initialize settings stored in a bank.
- The pressure check set value changes to match the sensor head that was connected.
- The calibration setting and key lock setting are not initialized.

## Setting method

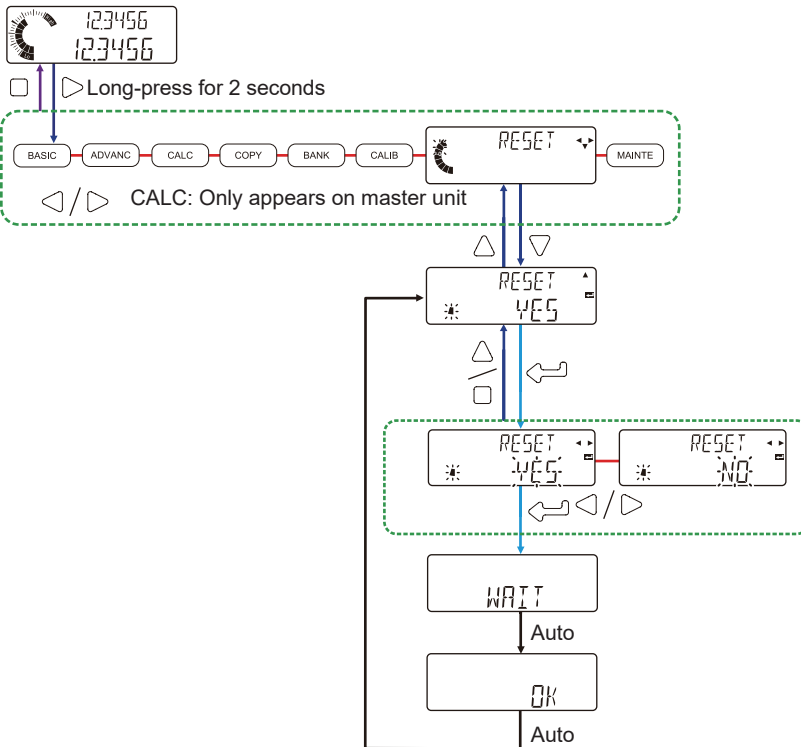

# FUNCTION SETTINGS

## 5-9 Maintenance (MAINTE)

- Structure of maintenance menu

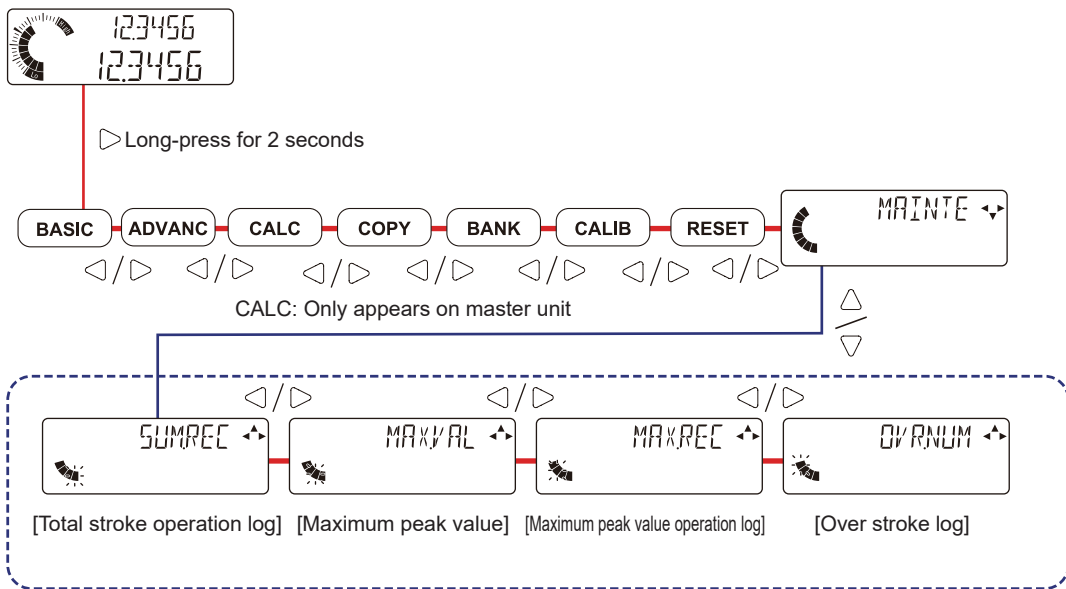

You can display the sensor head operation log and other information.

Maintenance	Function
Total stroke operation log (SUM.REC)	Shows the cumulative distance the spindle has moved. Display units are 1m.
Maximum peak value (MAX. VAL)	Shows the maximum value during operation.
Maximum peak value operation log (MAX.REC)	Shows the cumulative operation distance when the maximum peak value occurred. Display units are 1m.
Over stroke log (OVR.NUM)	Shows a log of the number of times the maximum stroke was exceeded.

## Setting method

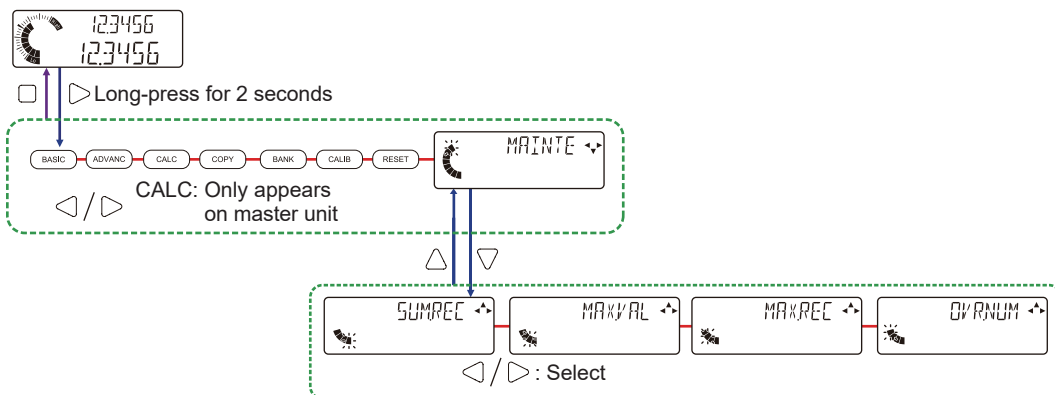

Setting item	Set values	Default value
Maintenance (MAINTE)	Total stroke operation log (SUM.REC) Maximum peak value (MAX.VAL) Maximum peak value operation log (MAX.REC) Over stroke log (OVR.NUM)	—

(MEMO)

# Chapter 6 SPECIFICATIONS

---

6-1 Specifications .....	6-2
6-2 Dimensions .....	6-7

# SPECIFICATIONS

## 6-1 Specifications

### • Controller

Type		Master unit		Slave unit		
		High-performance type		Standard type	Wire-saving type	
Model No.	NPN output	HG-SC101	HG-SC111	HG-SC112	HG-SC113	
	PNP output	HG-SC101-P	HG-SC111-P	HG-SC112-P		
Number of connectable units		Up to 15 slave units can be connected per master unit. (When communication unit consolidated: up to 14 slave units)				
Supply voltage		24V DC $\pm 10\%$ , including 0.5V ripple (P-P)				
Current consumption (Note 2)		70mA or less (when sensor head is connected)				
Analog current output (Note 3)		<ul style="list-style-type: none"> <li>Current output range: 4 to 20mA / F.S. (default value)</li> <li>Error output: 0mA</li> <li>Linearity: <math>\pm 0.25\%</math> F.S.</li> <li>Load impedance: 250<math>\Omega</math> max.</li> </ul>			—	
Control output (Output 1 / Output 2 / Output 3)		<p>&lt;NPN output type&gt; NPN open-collector transistor</p> <ul style="list-style-type: none"> <li>Maximum sink current: 50mA (Note 4)</li> <li>Applied voltage: 30V DC or less (between output and 0V)</li> <li>Residual voltage: 1.5V or less (at 50mA sink current)</li> <li>Leakage current: 0.1mA or less</li> </ul> <p>&lt;PNP output type&gt; PNP open-collector transistor</p> <ul style="list-style-type: none"> <li>Maximum source current: 50mA (Note 4)</li> <li>Applied voltage: 30V DC or less (between output and +V)</li> <li>Residual voltage: 1.5V or less (at 50mA source current)</li> <li>Leakage current: 0.1mA or less</li> </ul>			—	
Short-circuit protection		Incorporated (automatic reset type)				
Judgment output		NO / NC switching method				
Alarm output		Open when alarm occurs				
External output switching		Output 1 / Output 2 / Output 3 can be changed to "HI / GO / LO", "HI or LO / IN RANGE / ALARM", or "LO / HI / ALARM"			—	
External input (Input 1 / Input 2 / Input 3)		<p>&lt;NPN output type&gt; Non-contact input or NPN open-collector transistor</p> <ul style="list-style-type: none"> <li>Input condition: Invalid (+8V to +V DC or open) Valid (0 to +1.2V DC)</li> <li>Input impedance: Approx. 10k<math>\Omega</math></li> </ul> <p>&lt;PNP output type&gt; Non-contact input or PNP open-collector transistor</p> <ul style="list-style-type: none"> <li>Input condition: Invalid (0 to +0.6V DC or open) Valid (+4V to +V DC)</li> <li>Input impedance: Approx. 10k<math>\Omega</math></li> </ul>			—	
Trigger input		Input time 2ms or more (ON)				
Preset input		Input time 20ms or more (ON)				
Reset input		Input time 20ms or more (ON)				
Bank input A / B		Input time 20ms or more (ON)				
External input switching		Input 1 / Input 2 / Input 3 can be changed to "Preset / Reset / Trigger", "Bank Input A / Bank Input B / Select (Preset, Reset, Trigger)"				



## SPECIFICATIONS

Type		Master unit	Slave unit		
		High-performance type		Standard type	Wire-saving type
Model No.	NPN output	HG-SC101	HG-SC111	HG-SC112	HG-SC113
	PNP output	HG-SC101-P	HG-SC111-P	HG-SC112-P	
Response time		3ms, 5ms, 10ms, 100ms, 500ms, 1,000ms switching type			
Output 1 indicator		Orange LED (lights up when output 1 is ON)			
Output 2 indicator		Orange LED (lights up when output 2 is ON)			
Output 3 indicator		Orange LED (lights up when output 3 is ON)			
Input indicator		White LED (lights up when input is ON)			
Preset indicator		Green LED (lights up when preset is used)			
Display		Circle meter: Orange / Green LCD, Copy checkmark: Orange LCD Digital display / MAIN: White LCD, Digital display / SUB: Green LCD Guide mark / arrow key: White LCD, Guide mark / ENT: White LCD Status mark / TRIG: White LCD, Status mark / HOLD: White LCD Status mark / CALC: White LCD			
Display resolution		0.1μm			
Display range		-199.9999 to 199.9999mm			
Protection		IP40 (IEC)			
Contamination level		2			
Ambient temperature		-10 to +50°C (No dew condensation or icing allowed) (Note 4), Storage: -20 to +60°C			
Ambient humidity		35 to 85% RH, Storage: 35 to 85% RH			
Elevation		2,000m or less (Note 5)			
Insulation resistance		20MΩ or higher, using 250V DC megger connected between all supply terminals and case			
Withstand voltage		1,000V AC for one minute between all supply terminals and case			
Vibration resistance		10 to 150Hz with 0.75mm amplitude, maximum acceleration 49m/s <sup>2</sup> in X, Y and Z directions for two hours each			
Shock resistance		98m/s <sup>2</sup> (approx. 10G) in X, Y and Z directions 5 times each			
Material		Case: Polycarbonate, Cover: Polycarbonate, Switches: Polyacetal			
Cable		0.2mm <sup>2</sup> 2-conductor (brown and blue lead wires) / 0.15mm <sup>2</sup> 7-conductor 2m composite cable	0.15mm <sup>2</sup> 7-conductor 2m composite cable	0.15mm <sup>2</sup> 6-conductor 2m composite cable	—
Weight (main unit only)		Approx. 140g	Approx. 140g	Approx. 130g	Approx. 60g
Standards		EMC Directive			

- Notes: 1) Measured at a supply voltage of +24V DC and an ambient temperature of +20°C, unless otherwise indicated.  
 2) Current consumption does not include analog current output.  
 3) Linearity F.S. = 16mA, and is linearity with respect to digitally measured values.  
 4) When slave units are connected to the master unit, the maximum sink current / source current of the control output and ambient temperature vary depending on the number of connected slave units as shown below.

Number of connected slave units	Maximum sink current / source current of control output		Ambient temperature
	When communication unit consolidated		
1 to 7 units	1 to 6 units	20mA	-10 to +45°C
8 to 15 units	7 to 14 units	10mA	

- 5) Do not use or store in an environment that has been pressurized to an air pressure higher than the atmospheric pressure at 0m.

# SPECIFICATIONS

## • Sensor head (Regular type)

Type	10mm type				32mm type	
	General purpose		High precision		General purpose	
	Standard	Low measuring force	Standard	Low measuring force	Standard	
Model No.	<b>HG-S1010</b>	<b>HG-S1010R</b>	<b>HG-S1110</b>	<b>HG-S1110R</b>	<b>HG-S1032</b>	
Position detection method	Optical absolute linear encoder method					
Measurement range	10mm				32mm	
Stroke	10.5mm or more				32.5mm or more	
Measuring force (Note 1) (Note 2)	Downward mount	1.65N or less 1.10N (Note 3)	0.35N or less 0.30N (Note 3)	1.65N or less 1.10N (Note 3)	0.35N or less 0.30N (Note 3)	2.97N or less 1.90N (Note 3)
	Upward mount	1.35N or less 0.85N (Note 3)	—	1.35N or less 0.85N (Note 3)	—	2.09N or less 1.19N (Note 3)
	Side mount	1.50N or less 0.95N (Note 3)	0.25N or less 0.20N (Note 3)	1.50N or less 0.95N (Note 3)	0.25N or less 0.20N (Note 3)	2.53N or less 1.50N (Note 3)
Resolution	0.5μm		0.1μm		0.5μm	
Sampling cycle	1ms					
Indication accuracy (P-P) (Note 1)	Full range	2.0μm or less		1.0μm or less		3.0μm or less
	Narrow range	1.0μm or less (any 60μm)		0.5μm or less (any 60μm)		2.0μm or less (any 60μm)
Operation indicator	2-color (orange / green) LED					
Hot swap function	Incorporated					
Protective structure	IP67 (IEC) (Note 4)	—	IP67 (IEC) (Note 4)	—	IP67 (IEC) (Note 4)	
Ambient temperature	-10 to +55°C (No dew condensation or icing allowed), Storage: -20 to +60°C					
Ambient humidity	35 to 85% RH, Storage: 35 to 85% RH					
Insulation resistance	100MΩ or higher at DC 250V					
Vibration resistance	10 to 500Hz ( <b>HG-S1032</b> : 10 to 150Hz) with 3mm (maximum acceleration 196m/s <sup>2</sup> ) amplitude in X, Y and Z directions for two hours each					
Shock resistance	1,960m/s <sup>2</sup> in X, Y and Z directions 3 times each					
Mechanical life (Note 5)	100 million times or more ( <b>HG-S1032</b> : 30 million times or more) (reference value)					
Tip deviation amount	35μm (typical)				40μm (typical)	
Grounding method	Capacitor grounding					
Probe tightening torque	0.1 to 0.4N·m (no force applied to main unit)					
Material	Body: Zinc, ( <b>HG-S1032</b> : Aluminum), Holder: Stainless steel ( <b>HG-S1032</b> : Free-cutting steel) Spindle: Tool steel, Probe: Ceramic, Rubber bellows: NBR (black)					
Weight	Approx. 80g				Approx. 150g	
Standards	EMC Directive					

- Notes: 1) Measured at an ambient temperature of +20°C unless otherwise specified.  
 2) In the case of low measurement force type (**HG-S1010R** / **HG-S1110R**), measurements were obtained with products in standard configuration without rubber bellows.  
 3) Typical value near center of measurement.  
 4) Excludes damage and deterioration to rubber bellows due to external causes.  
 5) Typical value in a clean environment with no contact with dust or liquids such as water and oil.

## ● Sensor head (Air-driven type)

Type		General purpose		High precision	
Model No. (Note 2)		HG-S1010-AC		HG-S1110-AC	
		With no seal cap mounted		With no seal cap mounted	
Position detection method		Optical absolute linear encoder method			
Measurement range (Note 3)		10mm			
Stroke (Note 3)		10.5mm or more			
Measuring force (Note 4)	Downward mount	(Note 5)	(Note 5)	(Note 5)	(Note 5)
	Upward mount	(Note 5)	(Note 5)	(Note 5)	(Note 5)
	Side mount	(Note 5)	(Note 5)	(Note 5)	(Note 5)
Resolution		0.5μm		0.1μm	
Sampling cycle		1ms			
Indication accuracy (P-P)	Full range	2.0μm or less		1.0μm or less	
	Narrow range	1.0μm or less (any 60μm)		0.5μm or less (any 60μm)	
Operation indicator		2-color (orange / green) LED			
Working pressure range		0.14 to 0.16MPa	0.035 to 0.045MPa	0.16MPa	0.035 to 0.045MPa
Capacity to resist pressure		0.2MPa			
Usable fluid		Clean air (Dew point temperature: -10°C or lower)			
Applicable tube		Outside ø4mm / Inside ø2.5mm			
Protective structure (Note 6)		IP67 (IEC)	—	IP67 (IEC)	—
Contamination level		2			
Elevation (Note 7)		2,000m or lower			
Mechanical life (Note 8)		30 million times or more (Reference value)			
Tip deviation amount		35μm (typical)			
Grounding method		Capacitor grounding			
Insulation resistance		100MΩ or more at 250VDC			
Hot swap function		Incorporated			
Ambient temperature		-10 to +55°C (No dew condensation or icing allowed), Storage: -20 to +60°C			
Ambient humidity		35 to 85% RH, Storage: 35 to 85% RH			
Vibration resistance		10 to 500Hz with 3mm (maximum acceleration 196m/s <sup>2</sup> ) amplitude in X, Y and Z directions for two hours each			
Shock resistance		1,960m/s <sup>2</sup> in X, Y and Z directions 3 times each			
Probe tightening torque		0.1 to 0.4N·m (no force applied to main unit)			
Material		Body: Zinc, Holder: Stainless steel, Spindle: Tool steel, Probe: Ceramic (Note 9)			
Weight (main unit only)		Approx. 80g			
Standards		EMC Directive			

- Notes: 1) Measured at an ambient temperature of +20°C, unless otherwise specified.  
 2) Connect an **HG-S** series controller (manufactured in or after February 2019).  
 3) The position that represents "0" as an absolute value is a position where the spindle is pushed further down from the bottom dead point by 0.1mm or more. The term "stroke" indicates the total stroke length from the bottom dead point to the top dead point.  
 4) Measuring force changes with the air pressure used. Removing the seal cap enables the product to be used as the low measuring force type. For details on how to remove the seal cap, refer to "7-4-1 How to Remove the Seal Cap".

## SPECIFICATIONS

- 5) For the relationship between supplied air pressure and measuring force or between measuring force and pushed spindle position, see the figures below. For upward mount without a seal cap, subtract 0.2N from the measuring force. For side mount, subtract 0.1N from the measuring force. The following figures are only typical examples, and these relationships differ depending on the assembly accuracy of the product or the abrasion status of sealing materials.

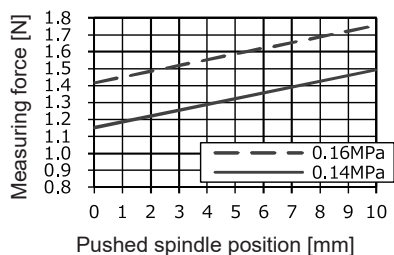

<Downward mount (typical example)>

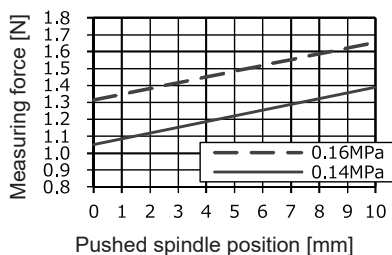

<Side mount (typical example)>

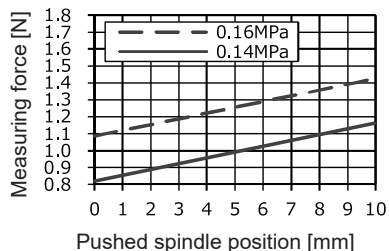

<Upward mount (typical example)>

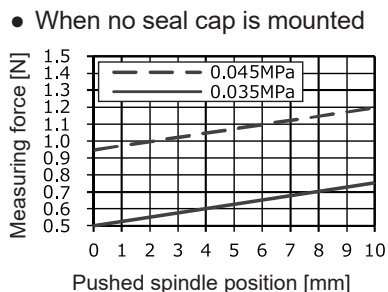

<Downward mount (typical example)>

- 6) Protective structure is not applicable when the sealing portions have deteriorated or become damaged. The protection level is zero when the seal cap is removed.
- 7) Do not use or store this product in environments where ambient air is pressurized to an air pressure higher than the atmospheric pressure at an altitude of 0 m.
- 8) Typical value in a clean environment with no contact with dust or liquids such as water and oil. The sealing material (O-ring) for the seal cap must be replaced at appropriate intervals. For approximate replacement intervals, refer to "How to replace the seal cap" in "7-4 Replacing the Seal Cap (Air-Driven Type Only)".
- 9) The probe is also available as an option.

6-2 Dimensions

- Controller

Units: mm

**HG-SC101, HG-SC101-P / Master unit, high-performance type**

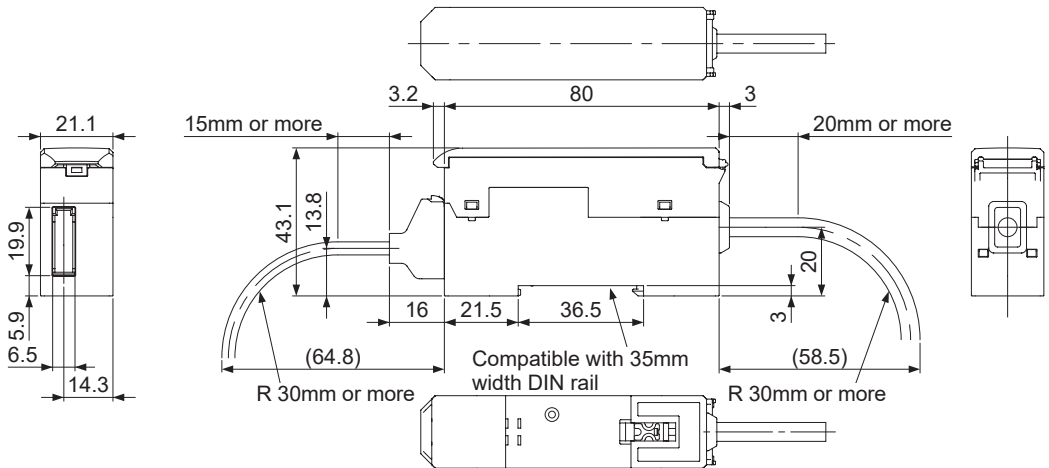

**HG-SC111, HG-SC111-P / Slave unit, high-performance type**  
**HG-SC112, HG-SC112-P / Slave unit, standard type**

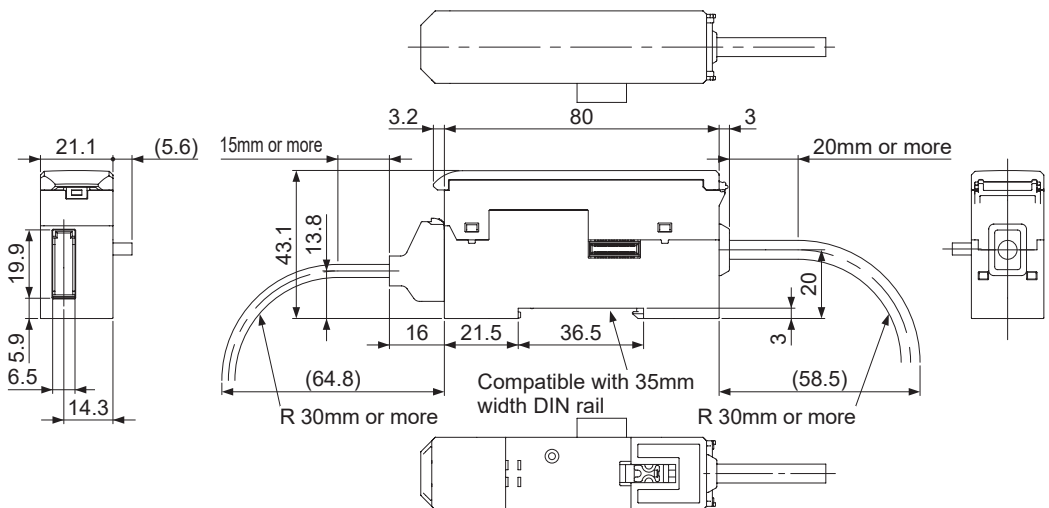

# SPECIFICATIONS

## HG-SC113 / Slave unit, wire-saving type

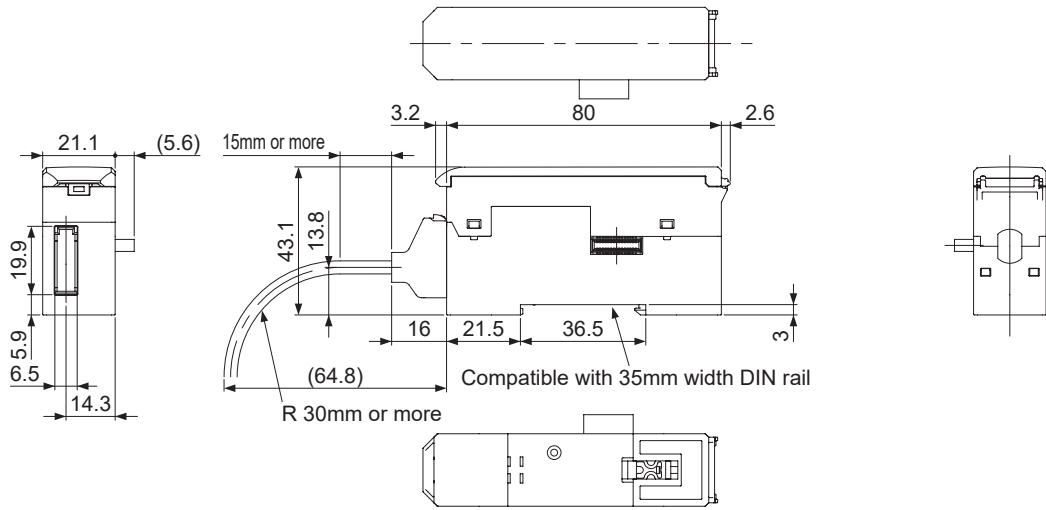

- Contact-Type Digital Displacement Sensor

Units: mm

- HG-S1010 / General purpose, standard, 10mm type
- HG-S1010R / General purpose, low measuring force, 10mm type
- HG-S1110 / High-performance, standard, 10mm type
- HG-S1110R / High-performance, low measuring force, 10mm type

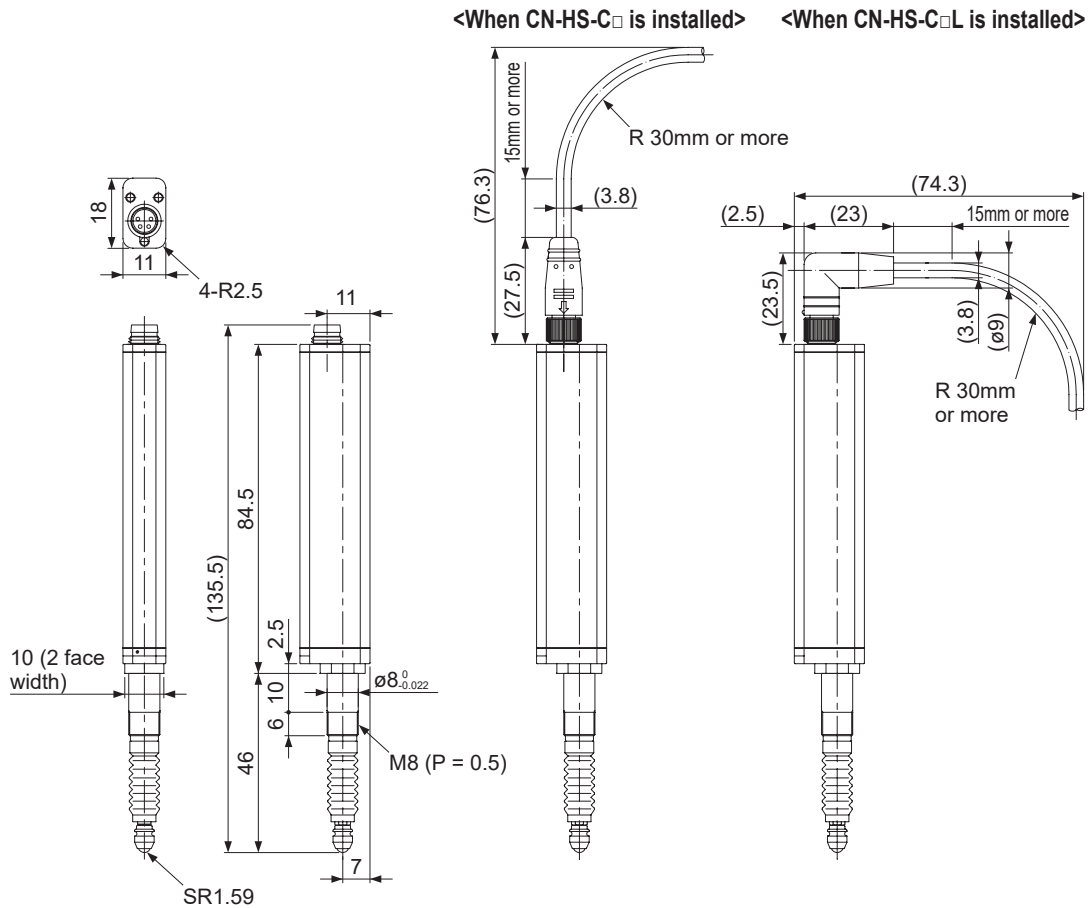

Note: The **HG-S□R** low measuring force type is not equipped with rubber bellows.

# SPECIFICATIONS

Units: mm

## HG-S1032 / General purpose, standard, 32mm type

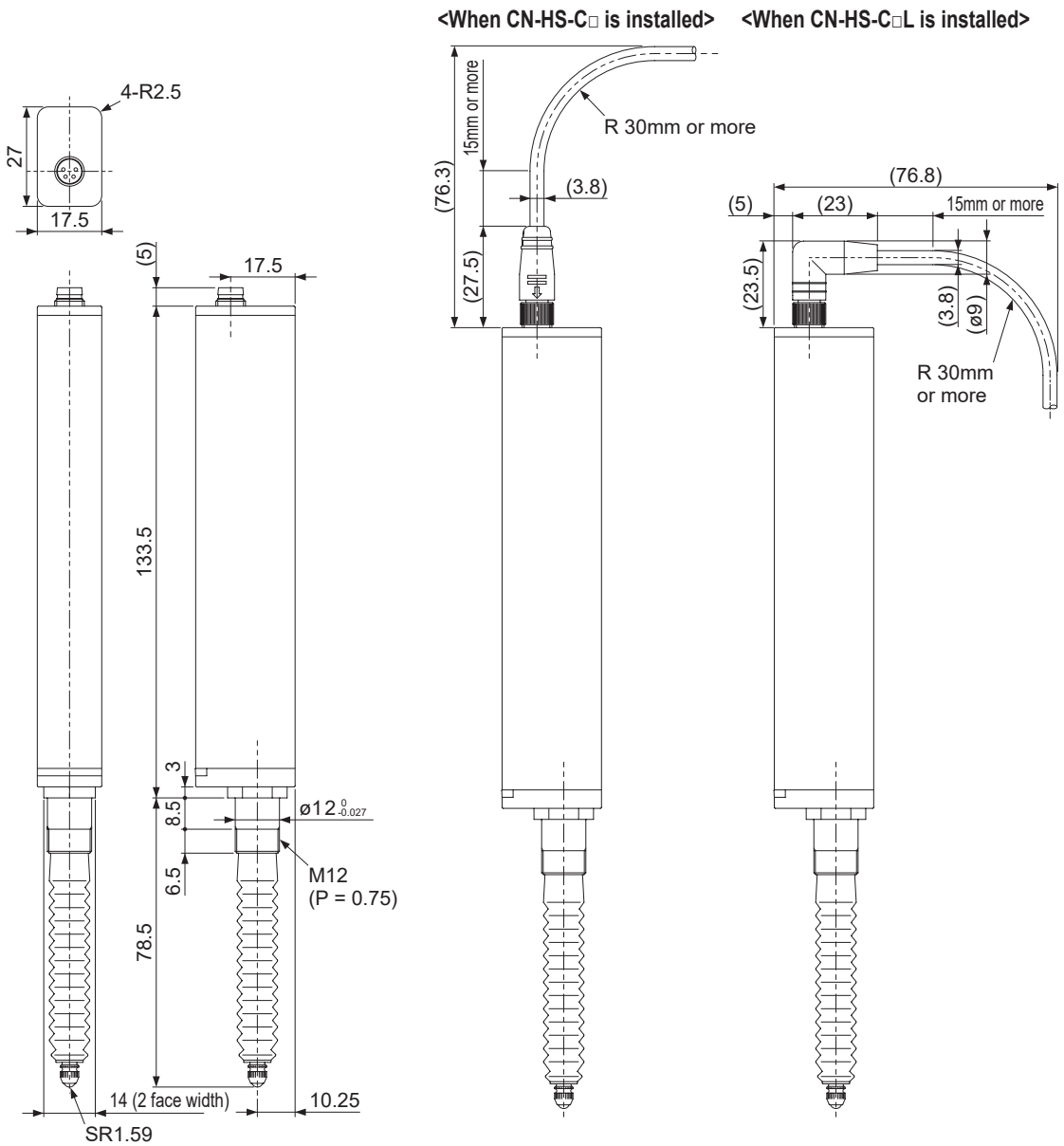



# SPECIFICATIONS

Units: mm

**HG-S1010-AC / General purpose, air-driven type**  
**HG-S1110-AC / High accuracy, air-driven type**

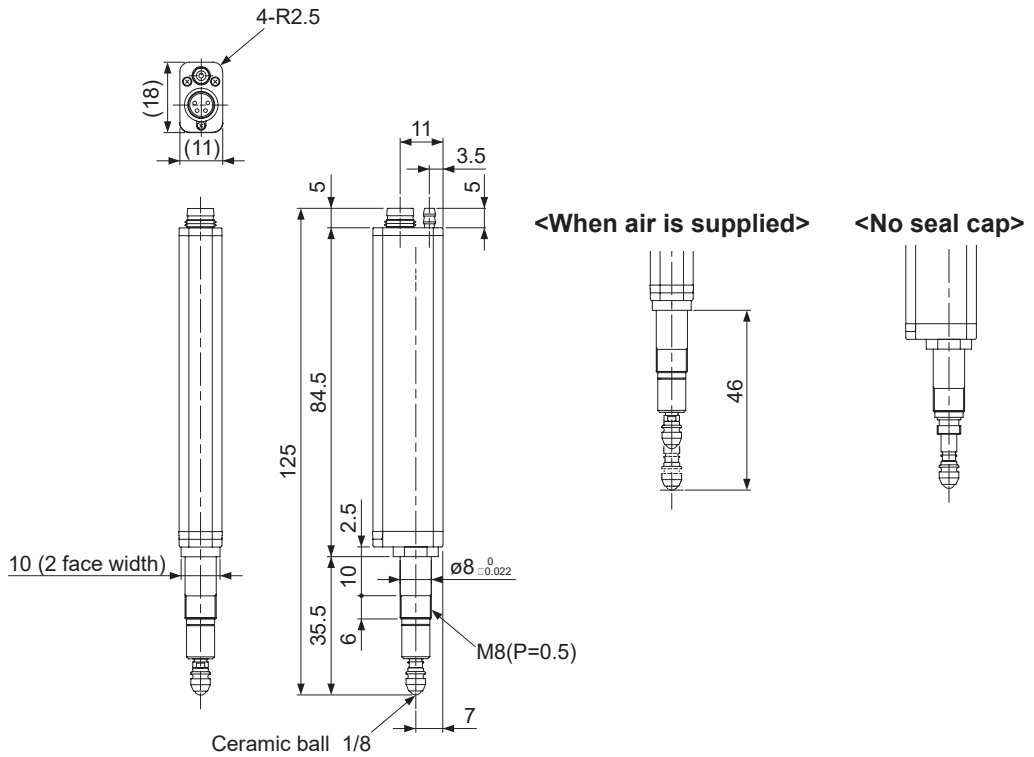

⟨ When CN-HS-C□ is installed  
 When air tube is attached ⟩

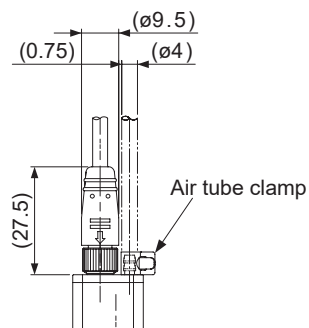

(MEMO)

# Chapter 7 Appendix

---

7-1 Maintenance and Inspection	7-2
7-1-1 Maintenance Cautions	7-2
7-1-2 Main Inspection Items	7-2
7-2 Replacing the Probe	7-3
7-3 Replacing the Rubber Bellows (Regular Type Only)	7-4
7-4 Replacing the Seal Cap (Air-Driven Type Only)	7-6
7-4-1 How to Remove the Seal Cap	7-6
7-4-2 How to Mount the Seal Cap	7-6
7-5 Error Messages	7-7
7-6 Troubleshooting	7-8

## APPENDIX

---

### 7-1 Maintenance and Inspection

#### 7-1-1 Maintenance Cautions

- Always turn OFF the power before cleaning the controller.
- Never use thinner, benzene, or other organic solvents to clean the controller.
- Use a clean, soft cloth to wipe off any dirt that adheres to the controller.

#### 7-1-2 Main Inspection Items

Inspect the controller regularly to maintain performance and enable optimum use. The main inspection items are as follows:

- Have any input/output terminals become loose or come OFF?
- Is the supplied power within the rated voltage range (24V DC  $\pm 10\%$ )?
- Is the ambient operating temperature within the specified range (-10 to +50°C)?
- Is the ambient operating humidity within the specified range (35 to 85% RH)?

## 7-2 Replacing the Probe

- ⊘ Always secure the spindle to prevent rotation before replacing the probe. Risk of product damage if an excessive torque (0.2N·m or more) is applied to the spindle.
- If the rubber bellows is damaged or deformed during probe replacement, the specifications of the protective structure may not be satisfied.

1. Turn the probe screw in the direction of the arrow and remove the probe from the spindle. When turning the probe screw, hold the cut face of the spindle with the provided sensor head fastening wrench to prevent the spindle from turning. Hold the sensor head fastening wrench in place, and turn only the probe.

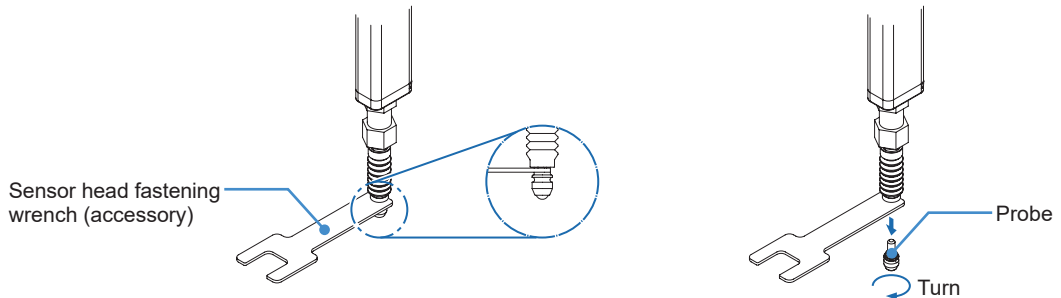

2. Attach the probe to the spindle. The tightening torque should be 0.4N·m or less. Make sure that the probe does not come OFF. When turning the probe screw, hold the cut face of the spindle with the provided sensor head fastening wrench to prevent the spindle from turning. Hold the sensor head fastening wrench in place, and turn only the probe.

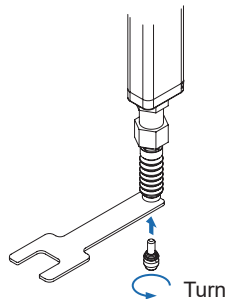

3. After attaching the probe, wipe the spindle with absolute alcohol to remove any dirt.

## 7-3 Replacing the Rubber Bellows (Regular Type Only)



- When replacing the rubber bellows, take care that no dirt or other contaminants get on the spindle. Risk of malfunctioning. If any dirt gets on the spindle, wipe clean with absolute alcohol. Do not allow the rubber bellows to become twisted during attachment.
- Note that the measuring force will vary depending on the attachment state of the rubber bellows.

- 1.** Turn the probe screw in the direction of the arrow and remove the probe from the spindle. When turning the probe screw, hold the cut face of the spindle with the provided sensor head fastening wrench to prevent the spindle from turning. Hold the sensor head fastening wrench in place, and turn only the probe.

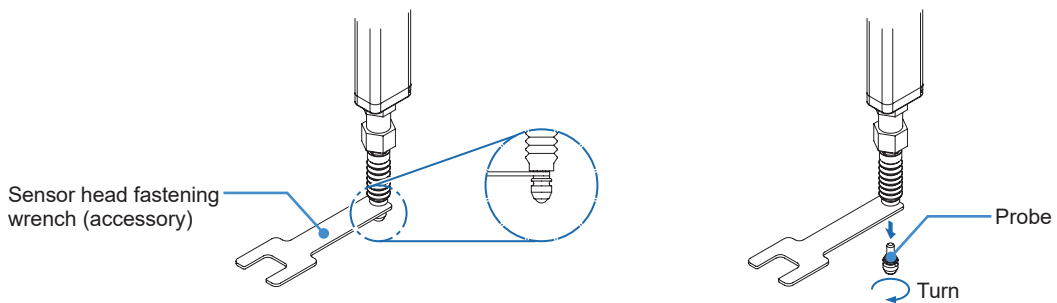

- 2.** Remove the rubber bellows from the spindle.

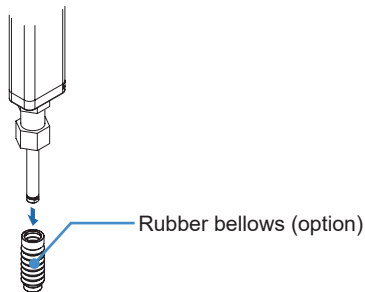

- 3.** Fit the new rubber bellows onto the spindle. Insert to the top edge as shown below.

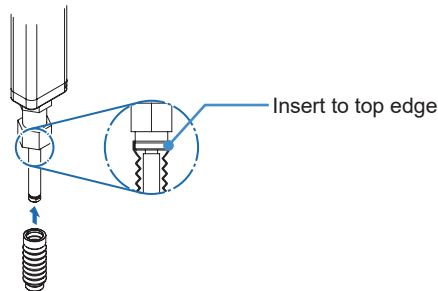

4. Push the rubber bellows up with your finger until the tip of the spindle is exposed as shown below.

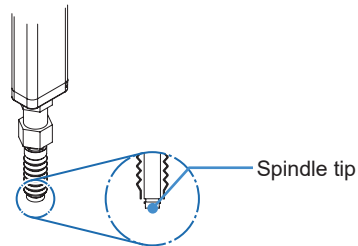

5. Attach the probe to the spindle.  
 The tightening torque should be 0.4N·m or less. Make sure that the probe does not come OFF. When turning the probe screw, hold the cut face of the spindle with the provided sensor head fastening wrench to prevent the spindle from turning. Hold the sensor head fastening wrench in place, and turn only the probe.

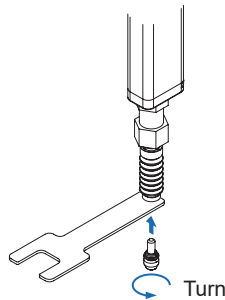

6. Make sure that the rubber bellows has not become deformed as shown below.  
 If the rubber bellows is deformed, restore the normal shape by rotating the bellows or otherwise.

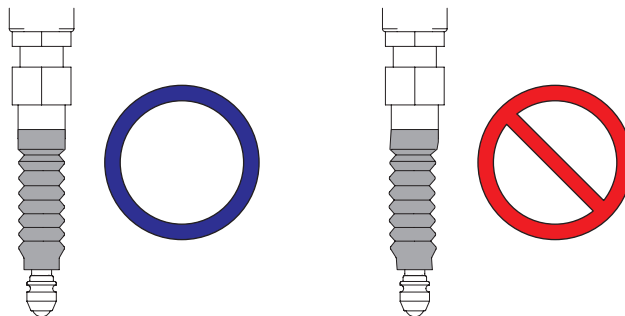

 If the rubber bellows is deformed, a load will occur when the spindle operates and damage may result.

## APPENDIX

### 7-4 Replacing the Seal Cap (Air-Driven Type Only)

Replace the seal cap at appropriate intervals according to the deterioration status of the sealing material.

Replace the seal cap when the number of sliding operations reaches approximately five million.



- When removing or mounting the seal cap, always remove the product from the housing.
- When removing or mounting the seal cap, stop supplying air.
- To prevent problems, replace the seal cap before the internal O-ring becomes worn.

#### 7-4-1 How to Remove the Seal Cap

1. Remove the probe.
2. While pulling the seal cap, expose the edge of the O-ring.
3. Loosen the seal cap by rotating it in the direction indicated by the arrow.
4. After loosening the seal cap completely, pull it out.
5. Finally, remove the O-ring.

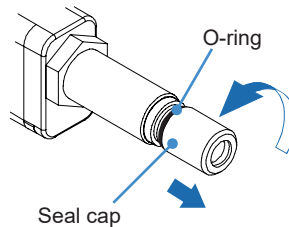

#### 7-4-2 How to Mount the Seal Cap

1. Mount the O-ring in the specified position.
2. Slide the seal cap onto the spindle and move it to a position where it can rotate at no load.
3. Push in the seal cap while rotating it in the direction indicated by the arrow.

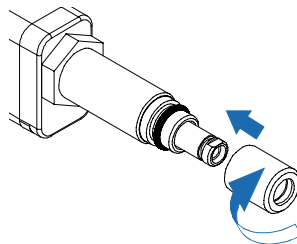



## 7-5 Error Messages

If an error occurs during configuration of settings or measurement, one of the error numbers below will appear.

Error number	Cause	Solution
E 100	Both NPN output types and PNP output types are connected.	Connect only units of the same output type.
E 110	Number of connectable units exceeded.	Connect no more than 15 slave units per master unit. (When communication unit consolidated: up to 14 slave units)
E 120	Cannot communicate between controllers.	Switch OFF the power, make sure the controllers are connected correctly, and then switch ON the power again.
E 130		
E 140	The calculation function is valid but no slave units are connected.	Change calculation mode to OFF.
E 150	The calculation function is valid but an insufficient number of slave units are connected.	Change calculation mode to OFF, or change the calculation application selection setting.
E 160	The saved number of connected units does not match the actual number of connected units.	Set the number of connected units check function to OFF.
E200	<ul style="list-style-type: none"> <li>• Sensor head not connected.</li> <li>• Broken wire in sensor head connection cable.</li> <li>• Sensor head failure.</li> </ul>	<ul style="list-style-type: none"> <li>• Check if the sensor head is correctly connected.</li> <li>• Check if there is a broken wire in the sensor head connection cable. If there is a broken wire in the sensor head connection cable, replace the cable.</li> <li>• Replace the sensor head.</li> </ul>
E210	The thrust on the sensor head stroke is above the specified range.	Check the sensor head mounting and measurement object installation position, and adjust so that the stroke is within the specified range.
E500	Unable to preset by external input.	Check if the power has just been switched on or reset has just been input, or if a display value is outside the display upper/lower limit or an alarm has occurred.
E600	<ul style="list-style-type: none"> <li>• Failed to write to or read from EEPROM.</li> <li>• The EEPROM write count is over the service life of 1 million.</li> </ul>	<ul style="list-style-type: none"> <li>• Switch the power OFF then ON, and execute initialization of the controller from setting mode.</li> <li>• If the controller does not recover after the above, it is possible that the EEPROM write count is over 1 million. Replace the controller.</li> </ul>
E610		
E620		
E700	The detection output load has short-circuited and excessive current is flowing.	Switch OFF the power and check the load.
E900	An error has occurred in the internal controller.	Switch the power OFF then ON, and execute initialization of the controller from setting mode.
E910		
E911		
E912		
E920		

### <Important>

If an error occurs again after you cleared it,

- Check if an excessive force is applied to the controller or the sensor head.
- If the product still does not operate normally after you check the above, consult our technical support center.

# APPENDIX

## 7-6 Troubleshooting

Solutions to frequently encountered problems and errors are described below.

### <Reference>

- Check the wiring.
- Check the voltage and capacity of the power supply.

### ■All indicators are OFF

Cause	Solution
Power is not supplied.	Check if the capacity of the power supply is sufficient. Connect the power supply correctly.
The power supply voltage is not within the specifications.	Correctly set the power supply voltage.
A connector is not firmly connected.	Firmly connect the connector.

### ■The correct judgment value is not displayed

Cause	Solution
The object to be measured is not within the measurement range.	Check the measurement range of the sensor head you are using.
Zero setting has not been performed.	When you use the <b>HG-S</b> Series for the first time, or after replacing the sensor head, perform zero-point adjustment.
The calculation mode is not set correctly.	If you are using connected controllers, check the calculation mode.

### <Important>

If the product still does not operate normally after you check the above, consult our technical support center.

## Revision History

1st edition, November 30, 2015

2nd edition, May 20, 2016

3rd edition, November 15, 2016

4th edition, January 31, 2017

5th edition, April 25, 2019

(MEMO)

## **1. WARRANTIES:**

- (1) Subject to the exclusions stated in 2 (EXCLUSIONS) herein below, Panasonic Industrial Devices SUNX warrants the Products to be free of defects in material and workmanship for a period of one (1) year from the date of shipment under normal usage in environments commonly found in manufacturing industry.
- (2) Any Products found to be defective must be shipped to Panasonic Industrial Devices SUNX with all shipping costs paid by Purchaser or offered to Panasonic Industrial Devices SUNX for inspection and examination. Upon examination by Panasonic Industrial Devices SUNX, Panasonic Industrial Devices SUNX will, at its sole discretion, repair or replace at no charge, or refund the purchase price of, any Products found to be defective.

## **2. EXCLUSIONS:**

- (1) This warranty does not apply to defects resulting from any cause:
  - (i) which was due to abuse, misuse, mishandling, improper installation, improper interfacing, or improper repair by Purchaser;
  - (ii) which was due to unauthorized modification by Purchaser, in part or in whole, whether in structure, performance or specification;
  - (iii) which was not discoverable by a person with the state-of-the-art scientific and technical knowledge at the time of manufacture;
  - (iv) which was due to an operation or use by Purchaser outside of the limits of operation or environment specified by Panasonic Industrial Devices SUNX;
  - (v) which was due to normal wear and tear;
  - (vi) which was due to Force Majeure; and
  - (vii) which was due to any use or application expressly discouraged by Panasonic Industrial Devices SUNX in 4 (CAUTIONS FOR SAFE USE) hereunder.
- (2) This warranty extends only to the first purchaser for application, and is not transferable to any person or entity which purchased from such purchaser for application.

## **3. DISCLAIMERS**

- (1) Panasonic Industrial Devices SUNX's sole obligation and liability under this warranty is limited to the repair or replacement, or refund of the purchase price, of a defective Product, at Panasonic Industrial Devices SUNX's option.
- (2) THE REPAIR, REPLACEMENT, OR REFUND IS THE EXCLUSIVE REMEDY OF THE PURCHASER, AND ALL OTHER WARRANTIES, EXPRESS OR IMPLIED, INCLUDING, WITHOUT LIMITATION, THE WARRANTIES OF MERCHANTABILITY, FITNESS FOR A PARTICULAR PURPOSE, AND NON-INFRINGEMENT OF PROPRIETARY RIGHTS, ARE HEREBY EXPRESSLY DISCLAIMED. IN NO EVENT SHALL PANASONIC INDUSTRIAL DEVICES SUNX AND ITS AFFILIATED ENTITIES BE LIABLE FOR DAMAGES IN EXCESS OF THE PURCHASE PRICE OF THE PRODUCTS, OR FOR ANY INDIRECT, INCIDENTAL, SPECIAL OR CONSEQUENTIAL DAMAGES OF ANY KIND, GENERAL TERMS AND CONDITIONS 4 OR ANY DAMAGES RESULTING FROM LOSS OF USE, BUSINESS INTERRUPTION, LOSS OF INFORMATION, LOSS OR INACCURACY OF DATA, LOSS OF PROFITS, LOSS OF SAVINGS, THE COST OF PROCUREMENT OF SUBSTITUTED GOODS, SERVICES OR TECHNOLOGIES, OR FOR ANY MATTER ARISING OUT OF OR IN CONNECTION WITH THE USE OR INABILITY TO USE THE PRODUCTS.

## **4. CAUTIONS FOR SAFE USE**

- (1) The applications shown in the catalogue are only suggestions, and it is Purchaser's sole responsibility to ascertain the fitness and suitability of the Products for any particular application, as well as to abide by Purchaser's applicable local laws and regulations, if any.
- (2) Never use the Products NOT rated or designated as "SAFETY SENSOR" in any application involving risk to life or property. When such a use is made by Purchaser, such Purchaser shall indemnify and hold harmless Panasonic Industrial Devices SUNX from any liability or damage whatsoever arising out of or in relation to such use.
- (3) In incorporating the Products to any equipment, facilities or systems, it is highly recommended to employ fail-safe designs, including but not limited to a redundant +++design, flame propagation prevention design, and malfunction prevention design so as not to cause any risk of bodily injury, fire accident, or social damage due to any failure of such equipment, facilities or systems.
- (4) The Products are each intended for use only in environments commonly found in manufacturing industry, and, unless expressly allowed in the catalogue, specification or otherwise, shall not be used in, or incorporated into, any equipment, facilities or systems, such as those:
  - (a) which are used for the protection of human life or body parts;
  - (b) which are used outdoors or in environments subject to any likelihood of chemical contamination or electromagnetic influence;
  - (c) which are likely to be used beyond the limits of operations or environments specified by Panasonic Industrial Devices SUNX in the catalogue or otherwise;
  - (d) which may cause risk to life or property, such as nuclear energy control equipment, transportation equipment (whether on rail or land, or in air or at sea), and medical equipment;
  - (e) which are operated continuously each day for 24 hours; and
  - (f) which otherwise require a high level of safety performance similar to that required in those equipment, facilities or systems as listed in (a) through (e) above.

## **5. EXPORT CONTROL LAWS**

In some jurisdictions, the Products may be subject to local export laws and regulations. If any diversion or re-export is to be made, Purchaser is advised to abide by such local export laws and regulations, if any, at its own responsibility.

Please contact .....

## Panasonic Industrial Devices SUNX Co., Ltd.

■ Overseas Sales Division (Head Office): 2431-1 Ushiyama-cho, Kasugai-shi, Aichi, 486-0901, Japan

■ Telephone: +81-568-33-7861 ■ Facsimile: +81-568-33-8591

[panasonic.net/id/pidsx/global](http://panasonic.net/id/pidsx/global)

For sales network, please visit our website.

April, 2019 PRINTED IN JAPAN

© Panasonic Industrial Devices SUNX Co., Ltd. 2019  
WUME-HGS-5