

PMP SERIES

PANEL MOUNT PROPORTIONAL CONTROL SOLID STATE RELAYS

Crydom PMP Series Solid State Relays were developed to offer precise control of the power delivered to an AC load in a standard 22.5 mm industrial package. Quick and easy installation is coupled with low drive power requirements and efficient, reliable power SCR output. This compact new design offers up to 90 A_{RM} in ambient temperatures of 40°C. Be sure to visit the product series datasheet available at the Sensata website to complement this information. If you have questions or need additional information please contact Tech Support. Please read all instructions before using your Proportional Control Solid State Relay (SSR)

MOUNTING INSTRUCTIONS

Choose one of the two mounting options and follow the instructions.

Mounting on Heat Sink

- Select adequate heat sink (see thermal derating curves in product series' datasheet).
- Be sure to use a thermal pad or thermal compound (0.006-0.008 in layer thickness recommended) between the SSR and the selected heat sink.
- SSR housing mounting holes have a diameter of 0.341 in (8.66 mm). Two screws are needed to mount the SSR onto a heat sink (See fig.1). Mounting screws are sold separately as HK8 and are suitable for all Crydom heat sinks.
- Otherwise, recommended screw size is 8-32 (socket) using an allen wrench (9/64 in) for the installation. Choose screw length considering mounting surface hole depth and SSR baseplate thickness of 0.125 in (3.2 mm).
- Before applying full torque tighten down both screws until they contact the baseplate.
- Then, tighten them to 20 lb-in (2.2 Nm) min.
- For optimal thermal performance heat sink fins should be oriented vertically to promote natural convection airflow.

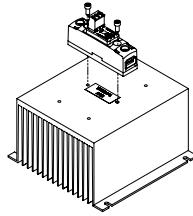

fig. 1 SSR mounted on HS053 heat sink

Mounting on Panel

- Locate the panel section on which the SSR will be mounted. Panel mount surface must provide adequate heat sinking capability, uncoated, clean, flat (0.004 in/in recommended) and preferably aluminum.
- Be sure to use a thermal pad or thermal compound (0.006-0.008 in layer thickness recommended) between the SSR and the panel.
- SSR housing mounting slots have a diameter of 0.341 in (8.66 mm). Two screws are needed (not included) to mount the SSR onto a panel. Mounting screws are sold separately as HK8. Otherwise, recommended screw size is 8-32 (socket) using allen wrench (9/64 in) for the installation. Choose screw length considering the mounting surface and that the SSR baseplate thickness is 0.125 in (3.2 mm).
- Before applying full torque tighten down both screws until they contact the baseplate. Then, tighten them to 20 lb-in (2.2 Nm) min.

ORDERING OPTIONS

PMP - 24 - 25 - W - P - H

Series	PMP
Operating Voltage	24: 90-280 VAC 48: 345-530 VAC 60: 420-600 VAC
Rated Load Current	25: 25 Amps 50: 50 Amps 90: 90 Amps
Terminal Layout	W: Contactor Configuration (elevator screw)
Overvoltage Protection	Blank: Not Included P: Included
Thermal Pad	Blank: Not Included H: Included

PMP - 24 - 25 - W - P - H

— Required for valid part number
□ For options only and not required for valid part number

WIRING DIAGRAM

Terminals

Maximum recommended terminal screw torque input terminal: 5 in-lb (0.5 Nm)
 Maximum recommended terminal screw torque load terminal: 18-20 lb-in (2.0-2.2 Nm)
 Recommended wire sizes as shown in TABLE 1.

Important Considerations

Be sure to use input and output voltages within operating ranges.
 LED provides status operation of the SSR, as shown in TABLE 3

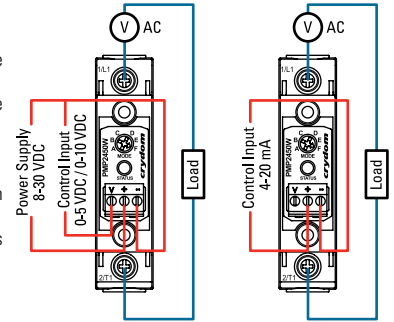

Terminal Type	Wire Size (Solid / Stranded)	Wire Pull-Out Strength (lb)[N]
Output	2 x 20 AWG (0.75 mm ²) [minimum]	25 [111]
	2 x 10 AWG (6 mm ²)	80 [355]
	2 x 8 AWG (10 mm ²) [maximum]	90 [400]
Input	28 AWG (0.09 mm ²) [minimum]	2.2 [9.8]
	12 AWG (3.3 mm ²) [maximum]	22 [98]

Parameter Selector Switch	Mode	Function
	A	Phase Angle, 0-5 VDC control
	B	Phase Angle, 0-10 VDC control
	C	Phase Angle, 4-20 mA control
	D	Burst Fire, 0-5 VDC control
	E	Burst Fire, 0-10 VDC control
	F	Burst Fire, 4-20 mA control

DERATING CURVES (D)

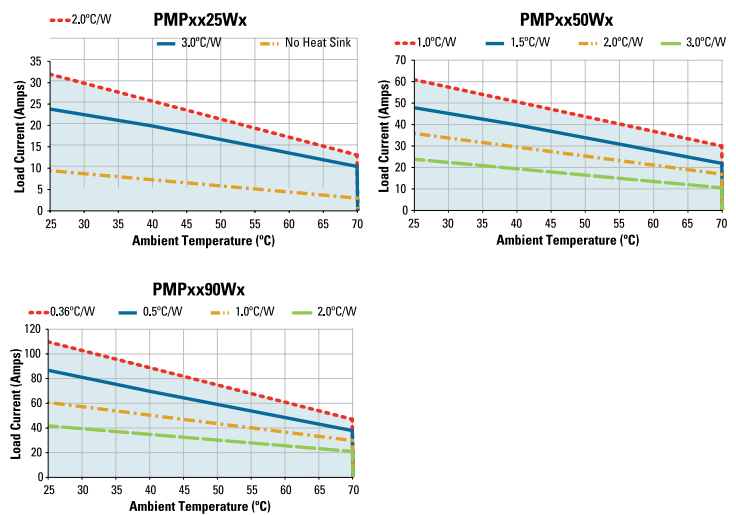

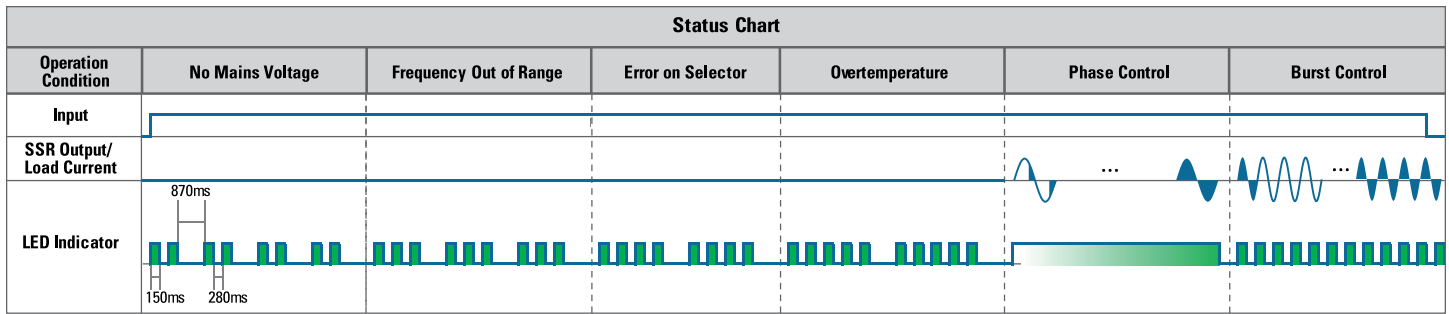

Status	LED Indicator	SSR Output
No Mains Voltage	Flashes twice intermittently	OFF
Frequency Out of Range	Flashes three times intermittently	OFF
Error on Selector	Flashes four times intermittently	OFF
Overtemperature	Flashes five times intermittently	OFF
Phase Control	Varying brightness	ON
Burst Control	Varying frequency	ON

Terminals	Fork LugR	Ring Lug	Copper Lug	Copper Lug
Crydom Part No.			TRM0	TRM6
Width [W] in (mm)	0.45 (11.4)	0.45 (11.4)		
Stud Size Dia [D] (in)	#8 (0.168)	#8 (0.168)		
Wire Size AWG			6-0	14-6

ELEVATOR SCREW ("W" SUFFIX) CONSIDERATIONS

- The Elevator Screw option allows the screw and clamp to be raised out of the mating threads completely. This provides for the insertion and use of a ring or lug type wire terminal.
- A #2 Phillips head driver should be used with the Elevator Screws. If a powered driver is used, avoid speeds above 500 RPM.
- Cutting threads in the cover plastic as the screw elevates is key to the elevating feature. It has a finite life and therefore not recommended to be used more than 50 times during the product lifetime.
- Do not continue rotating the screw (in the elevating direction) once it freely rotates at the top of the plastic surface. The Elevator screw is capable of clearing 0.125 inches between the terminal and the bottom of the screw. Insertion of a terminal or lug thicker than 0.125 in is not recommended.
- When inserting the terminal ensure that the terminal hole is in line with the screw.
- During tightening, be certain that the terminal is seated flat within the cavity, and that the clamping washer is secure against the upper surface of the terminal.
- If fork terminations, spade lugs, or stranded wire are used, to prevent improper contact do not raise the elevator screw out of the mating threads.

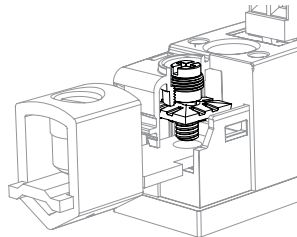

fig. 2 Elevator screw

ACCESSORIES

Hardware Kit	Heat Sink		Thermal Pad	Lug Terminal
	Part No.	Thermal Resistance [°C/W]		
HK8	HS259DR	2.5	HSP-7	TRM0 TRM6
	HS073	0.7		
	HS072	0.7		
	HS053	0.5		
	HS033	0.36		
	HS023	0.25		

GENERAL NOTES

- (A) The operation mode is detected during power up. Any changes done to the selector while the unit is powered will be ignored until next power up
- (B) UL approved rating is the one that intersects at 40°C.

Sensata Technologies, Inc. ("Sensata") data sheets are solely intended to assist designers ("Buyers") who are developing systems that incorporate Sensata products (also referred to herein as "components"). Buyer understands and agrees that Buyer remains responsible for using its independent analysis, evaluation and judgment in designing Buyer's systems and products. Sensata data sheets have been created using standard laboratory conditions and engineering practices. Sensata has not conducted any testing other than that specifically described in the published documentation for a particular data sheet. Sensata may make corrections, enhancements, improvements and other changes to its data sheets or components without notice.

Buyers are authorized to use Sensata data sheets with the Sensata component(s) identified in each particular data sheet. HOWEVER, NO OTHER LICENSE, EXPRESS OR IMPLIED, BY ESTOPPEL OR OTHERWISE TO ANY OTHER SENSATA INTELLECTUAL PROPERTY RIGHT, AND NO LICENSE TO ANY THIRD PARTY TECHNOLOGY OR INTELLECTUAL PROPERTY RIGHT, IS GRANTED HEREIN. SENSATA DATA SHEETS ARE PROVIDED "AS IS". SENSATA MAKES NO WARRANTIES OR REPRESENTATIONS WITH REGARD TO THE DATA SHEETS OR USE OF THE DATA SHEETS, EXPRESS, IMPLIED OR STATUTORY, INCLUDING ACCURACY OR COMPLETENESS. SENSATA DISCLAIMS ANY WARRANTY OF TITLE AND ANY IMPLIED WARRANTIES OF MERCHANTABILITY, FITNESS FOR A PARTICULAR PURPOSE, QUIET ENJOYMENT, QUIET POSSESSION, AND NON-INFRINGEMENT OF ANY THIRD PARTY INTELLECTUAL PROPERTY RIGHTS WITH REGARD TO SENSATA DATA SHEETS OR USE THEREOF.

All products are sold subject to Sensata's terms and conditions of sale supplied at www.sensata.com SENSATA ASSUMES NO LIABILITY FOR APPLICATIONS ASSISTANCE OR THE DESIGN OF BUYERS' PRODUCTS. BUYER ACKNOWLEDGES AND AGREES THAT IT IS SOLELY RESPONSIBLE FOR COMPLIANCE WITH ALL LEGAL, REGULATORY AND SAFETY-RELATED REQUIREMENTS CONCERNING ITS PRODUCTS, AND ANY USE OF SENSATA COMPONENTS IN ITS APPLICATIONS, NOTWITHSTANDING ANY APPLICATIONS-RELATED INFORMATION OR SUPPORT THAT MAY BE PROVIDED BY SENSATA. Mailing Address: Sensata Technologies, Inc., 529 Pleasant Street, Attleboro, MA 02703, USA.

CONTACT US

Americas
+1 (877) 502 5500
sales.crydom@sensata.com

Europe, Middle East & Africa
+44 (1202) 416170
ssr-info.eu@sensata.com

Asia Pacific
sales.isasia@list.sensata.com
China +86 (21) 2306 1500
Japan +81 (45) 277 7117
Korea +82 (31) 601 2004
India +91 (80) 67920890
Rest of Asia +886 (2) 27602006
ext 2808