

## 8-PORT ETHERNET SWITCH

(with surge protector)

### Functions & Features

- Surge protector function for each port
- Protects Ethernet devices from surges entering through LAN cables
- Surge protector life monitor function with LED and contact output alarm
- Data transfer rate can be fixed

### Typical Applications

- Risk managed system

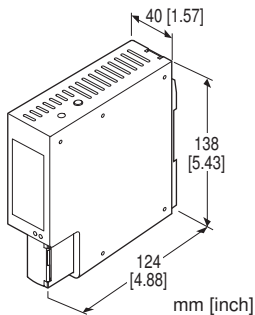

## MODEL: SHSP-1-[1][2]

### ORDERING INFORMATION

- Code number: SHSP-1-[1][2]
- Specify a code from below for each of [1] and [2].  
(e.g. SHSP-1-R/CE/Q)
- Specify the specification for option code /Q  
(e.g. /C01/SET)

## SURGE PROTECTOR

1: With

### [1] POWER INPUT

#### AC Power

**M2:** 100 - 240V AC (Operational voltage range 85 - 264 V, 47 - 66 Hz)

(Select '/N' for 'Standards & Approvals' code.)

#### DC Power

**R:** 24 V DC

(Operational voltage range 24 V  $\pm$ 10 %, ripple 10 %p-p max.)  
(Select '/CE' for 'Standards & Approvals' code.)

### [2] OPTIONS (multiple selections)

#### Standards & Approvals (must be specified)

/N: Without CE

/CE: CE marking

### Other Options

blank: none

/Q: Option other than the above (specify the specification)

### SPECIFICATIONS OF OPTION: Q (multiple selections)

#### COATING (For the detail, refer to M-System's web site.)

/C01: Silicone coating

/C02: Polyurethane coating

/C03: Rubber coating

#### EX-FACTORY SETTING

/SET: Preset according to the Ordering Information Sheet  
(No. ESU-9308)

### RELATED PRODUCTS

- PC configurator software (model: SHSPCFG)

Downloadable at M-System's web site.

A dedicated cable is required to connect the module to the PC. Please refer to the internet software download site or the users manual for the PC configurator for applicable cable types.

### GENERAL SPECIFICATIONS

**Surge protection:** All ports

**Connection**

**Ethernet:** RJ-45 connector

**Power input, grounding, alarm contact output:**

M3 separable screw terminal (torque 0.8 N·m)

**PC configurator:** Miniature jack

**Screw terminal:** Nickel-plated steel

**Housing material:** Steel, melamine baking finish (black)

**Monitor LED**

**Status:** Green/Red bicolor LED;

Green light turns on in normal conditions;

Red turns on in an abnormality.

(Amber light turns on for approx. 1 second while the internal processor is initialized at the startup.)

**Surge Protector:** Green/Amber/Red tricolor LED indicating the surge protector life.

OFF while no surge has been detected;

Green when the first surge has been detected;

Amber when the protector is close to the end of life;

Red at the end of life.

(Amber light turns on for approx. 1 second while the internal processor is initialized at the startup.)

**LINK LED:** Green LED indicating port link status.

ON with a link established; Flashes during communication.

**100M LED:** Amber LED indicating data transfer rate;

ON at 100 Mbps;

OFF at 10 Mbps.

**PC configuration:** PC Configurator Software is used to program;

- LAN port operating mode (Default setting: Auto negotiation)
- User password

## ■ ALARM CONTACT OUTPUT

Turns on when the surge protector life ends, when the power supply is lost, or when an internal error is detected.

### Rated load:

250 V AC @ 1.5 A (cos  $\phi$  = 1)(applicable only to AC powered model.)

30 V DC @ 1.5 A (resistive load)

**Minimum load:** 5 V DC @ 10 mA

**Mechanical life:**  $1 \times 10^7$  cycles (rate 180/min.)

## LAN PORT

**Standards:** IEEE 802.3, IEEE 802.3u, IEEE 802.3x

**Number of ports:** 8; All ports support AUTO-MDIX (Automatically sensing cable type, straight-through or cross-over)

**Data transfer rate:** 10 Mbps (10BASE-T), 100 Mbps (100BASE-TX); Supports Auto-Negotiation

**Cable:** 10BASE-T (STP cable, category 5)

100BASE-TX (STP cable, category 5e)

**Maximum segment length:** 100 meters

**Switching:** Store & Forward

**Flow control**

**Full duplex:** PAUSE Frames

**Half duplex:** Back pressure

**Buffer:** 64 KB

**MAC address table:** 1024

## INSTALLATION

•**AC:** Approx. 8 VA @ 100 V

Approx. 10 VA @ 200 V

Approx. 11 VA @ 264 V

•**DC:** Approx. 5.5 W

**Operating temperature:** -5 to +60°C (23 to 140°F)

**Operating humidity:** 30 to 95 %RH (non-condensing)

**Mounting:** DIN rail

**Weight**

•**AC powered:** 650 g (1.4 lb)

•**DC powered:** 600 g (1.3 lb)

## PERFORMANCE

**Compliant standard:** EN 61000-4-5 level X

**Between ports:** 1kV (combination waveform)

RJ-45 connector contact is out of the scope of this protection. Using twisted-pair (STP) LAN cable is effective to reduce risk of fusing contact.

**Port to G:** 10kV (combination waveform)

**FG (shield) to G:** 15kV (combination waveform) with the

shortcircuit bar

**Voltage protection level**

**Port to FG or G:** 160 V min.

**Between each port:** 160 V min.

**FG to G:** 160 V min. (with the shortcircuit bar removed)

**Insulation resistance:**  $\geq 100 \text{ M}\Omega$  with 100 V DC

(port or FG or G to alarm contact to power)

**Dielectric strength:** 2000 V AC @ 1 minute

(port or FG or G or power to alarm contact)

1500 V AC @ 1 minute

(port or FG or G to power)

## STANDARDS & APPROVALS

The following standards are applied only to DC powered model.

**EU conformity:**

EMC Directive

EN 55032 Class A (EMI)

EN 55035 (EMS)

RoHS Directive

**EXTERNAL VIEW**

**FRONT VIEW**

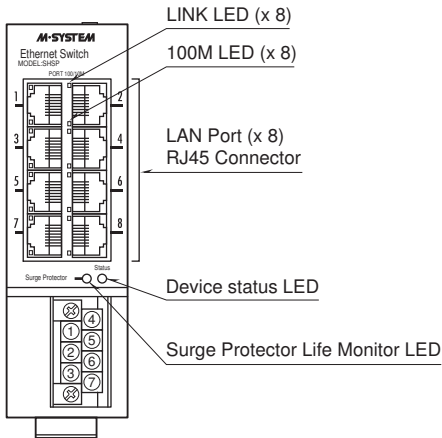

**TOP VIEW**

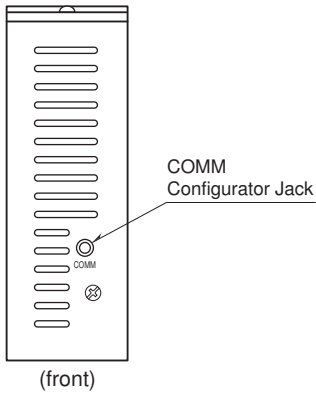

## CONNECTION DIAGRAM

### ■ AC POWERED

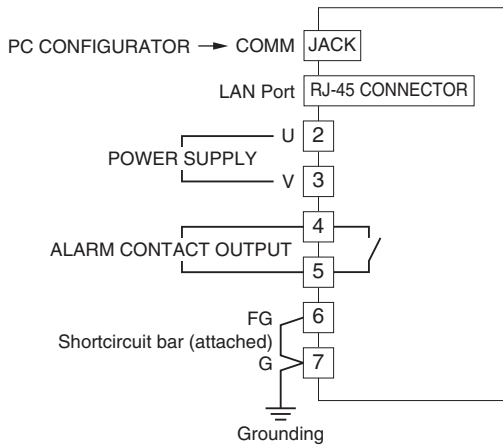

### ■ DC POWERED

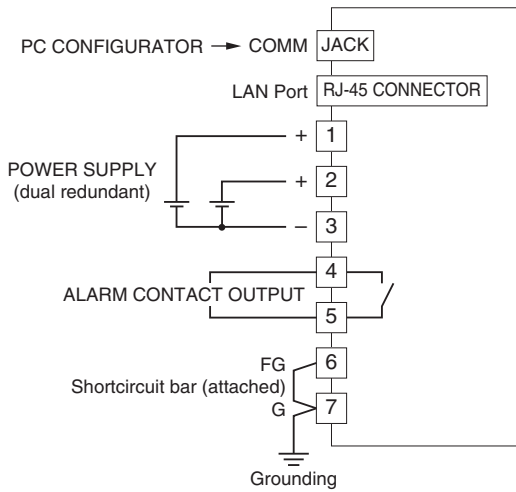

### ■ Relay Protection

#### • AC Powered

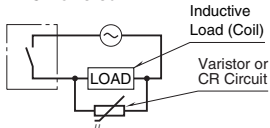

#### • DC Powered

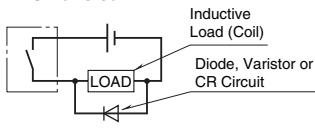

## EXTERNAL DIMENSIONS unit: mm [inch]

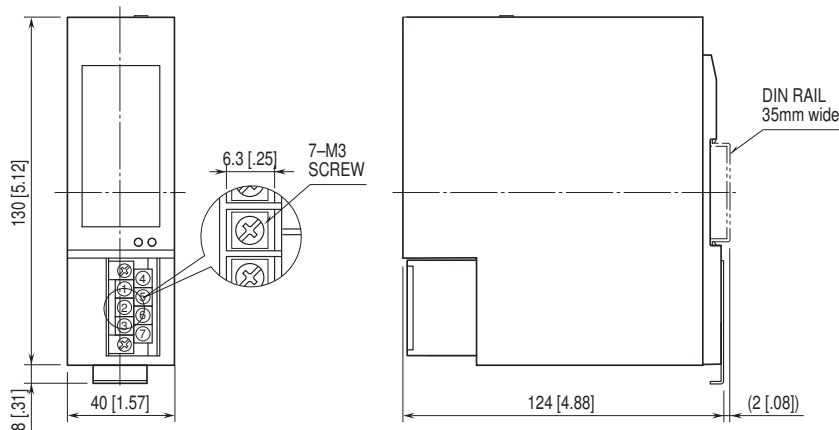



Specifications are subject to change without notice.