

Remote I/O R7 Series

HI-SPEED LINK SYSTEM I/O MODULE

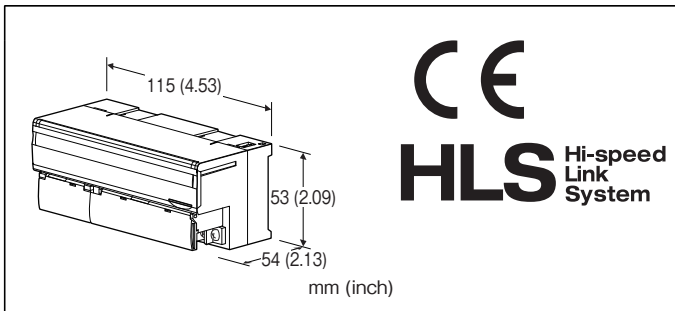

MODEL: R7HL-[1]-R[2]

ORDERING INFORMATION

- Code number: R7HL-[1]-R[2]
- Specify a code from below for each of [1] and [2].
(e.g. R7HL-PA2SA7-R/H/C/Q)
- Specify the specification for option code /Q
(e.g. /C01/SET)

[1] I/O TYPE

- DA16:** Discrete input, 16 points
- DC16A:** NPN transistor output, 16 points
- DC16B:** PNP transistor output, 16 points
- DAC15E:** Discrete input, 8 points
NPN transistor output, 7 points (independent I/O common)
- DAC16A:** PNP discrete input, 8 points
NPN transistor output, 8 points
- DAC16B:** NPN discrete input, 8 points
PNP transistor output, 8 points
- DAC16C:** NPN discrete input &
NPN transistor output, 8 points each
- DAC16ES:** Discrete input, 8 points
NPN transistor output, 8 points (independent I/O common)
- DC8C:** Relay contact output, 8 points
- SV4:** DC voltage/current input (10 V/20 mA), 4 points
- SVF4:** DC voltage/current input (10 V/20 mA), high speed, 4 points, non-isolated (CE not available)
- TS4:** Thermocouple input, 4 points
- RS4:** RTD input, 4 points
- LC2:** Strain gauge input, 2 points (with monitor output)
- PA4E:** Totalized pulse input, 4 points
- PA2Sj:** Encoder input (speed / position) 2 points
(RS-422 input)
- PA2SA1:** Encoder input (speed / position) 2 points
(5 V open collector input)
- PA2SA4:** Encoder input (speed / position) 2 points
(12 V open collector input)

- PA2SA7:** Encoder input (speed / position) 2 points
(24 V open collector input)
- YV2:** DC voltage output, 2 points
- YS2:** DC current output, 2 points
- SVF8NL:** DC voltage input, high speed, 8 points
(non-isolated, 12 bits data)
- YV4L:** DC voltage output, 4 points
(isolated, 12 bits data)

POWER INPUT

- DC Power**
- R:** 24 V DC
(Operational voltage range 24 V \pm 10 %, ripple 10 %p-p max.)

[2] OPTIONS (multiple selections)

Communication Mode

- blank:** Full-duplex
- /H:** Half-duplex

Transfer rate

- (Selectable only for SVF8NL and YV4L)
- blank:** 12 Mbps/6 Mbps
- /3:** 3 Mbps

Sensor Excitation

- (Selectable for PA2Sj and PA2SAx)
- blank:** External excitation
- /C:** Incorporated excitation

Input Range

- (Selectable only for LC2 (be sure to specify))
- /R20:** -2 - +2 mV/V
- /R10:** -1 - +1 mV/V
- /R05:** -0.5 - +0.5 mV/V

CR Filter

- (Selectable only for LC2 (be sure to specify))
- /F2K:** 2 kHz/2 Hz
- /F1:** 1 Hz/2 Hz

Other Options

- blank:** none
- /Q:** Option other than the above (specify the specification)

SPECIFICATIONS OF OPTION: Q (multiple selections)

COATING (For the detail, refer to M-System's web site.)

- /C01:** Silicone coating
- /C02:** Polyurethane coating
- /C03:** Rubber coating

EX-FACTORY SETTING

- /SET:** Preset according to the Ordering Information Sheet
(No. ESU-7812-x)

FUNCTIONS & FEATURES

The R7HL interfaces analog and discrete I/O signals with a PLC via HLS (Hi-speed Link System)

Input sensor type (thermocouple, RTD) and range can be selected with the front DIP switches for all channels. In order to set different selections for individual channels, zero/span adjustments, scaling and temperature unit, use the PC Configurator Software (model: R7CON) (HLS is the abbreviation for "Hi-speed Link System" of Step Technica Co., Ltd.)

RELATED PRODUCTS

- PC configurator software (model: R7CON)
Downloadable at M-System's web site.
A dedicated cable is required to connect the module to the PC. Please refer to the internet software download site or the users manual for the PC configurator for applicable cable types.

GENERAL SPECIFICATIONS

• Common Specifications

Power input: 24 V DC $\pm 10\%$; ripple 10 %p-p max.

Insulation resistance: $\geq 100\text{ M}\Omega$ with 500 V DC

Dielectric strength: 1500 V AC @1 minute
(between isolated circuits)

Operating temperature: -10 to +55°C (14 to 131°F)

Operating humidity: 30 to 90 %RH (non-condensing)

Atmosphere: No corrosive gas or heavy dust

Storage temperature: -20 to +65°C (-4 to +149°F)

Mounting: DIN rail (35 mm wide)

Housing material: Flame-resistant resin (gray)

Status indicator LEDs: PWR, RUN (Refer to the instruction manual for details)

■ Current consumption & weight

R7HL-DA16: Approx. 35 mA, 200 g (0.44 lb)
 R7HL-DC16A: Approx. 45 mA, 200 g (0.44 lb)
 R7HL-DC16B: Approx. 45 mA, 200 g (0.44 lb)
 R7HL-DAC15E: Approx. 40 mA, 200 g (0.44 lb)
 R7HL-DAC16A: Approx. 40 mA, 200 g (0.44 lb)
 R7HL-DAC16B: Approx. 40 mA, 200 g (0.44 lb)
 R7HL-DAC16C: Approx. 45 mA, 200 g (0.44 lb)
 R7HL-DAC16ES: Approx. 40 mA, 200 g (0.44 lb)
 R7HL-DC8C: Approx. 45 mA (60 mA*), 200 g (0.44 lb)
 R7HL-SV4: Approx. 90 mA, 200 g (0.44 lb)
 R7HL-SVF4: Approx. 90 mA, 200 g (0.44 lb)
 R7HL-TS4: Approx. 90 mA, 200 g (0.44 lb)
 R7HL-RS4: Approx. 90 mA, 200 g (0.44 lb)
 R7HL-LC2: Approx. 150mA, 220g (0.49 lb)
 R7HL-PA4E: Approx. 50 mA, 130 g (0.29 lb)
 R7HL-PA2Sx": Approx. 80 mA, 160 g (0.36 lb)
 R7HL-YV2: Approx. 100 mA, 200 g (0.44 lb)

R7HL-YS2: Approx. 140 mA, 200 g (0.44 lb)

R7HL-SVF8NL: 50 mA, 200 g (0.44 lb)

R7HL-YV4L: 75 mA, 180 g (0.40 lb)

* Relay driving current.

** Sensor excitation current is added for incorporated sensor excitation type.

HLS COMMUNICATION

Communication mode:

Communication mode option code blank: Full-duplex

Communication mode option code /H: half-duplex

Network cable

Full-duplex communication:

ZHY262PS and ZHT262PS (Shinko Seisen Industry Co., Ltd.)

Half-duplex communication:

ZHY221PS (Shinko Seisen Industry Co., Ltd.)

Dual-shield cable:

ZHY262PBA (Shinko Seisen Industry Co., Ltd.)

Transmission distance / Transfer rate:

Transfer rate option code blank: 100 meters (328 ft)/12

Mbps, 200 meters (656 ft)/6 Mbps

Transfer rate option code /3: 300 meters (984 ft)/3 Mbps

(Selectable with DIP switch)

Status indicator LED: RUN (Refer to the instruction manual for details)

Station address: Rotary switch

(Refer to the instruction manual)

Terminating resistor: Built-in (Selected with the DIP SW; factory setting: disabled)

STANDARDS & APPROVALS

Refer to the manuals to comply with the standards.

EU conformity:

EMC Directive

EMI EN 61000-6-4

EMS EN 61000-6-2

Low Voltage Directive

(R7HL-DC8C only. Refer to the instruction manual for the detail.)

EN 61010-1, EN 61010-2-201

Measurement Category II (output)

Pollution Degree 2

Output to power: Basic insulation (150 V)

RoHS Directive

EXTERNAL VIEW

■ View of R7HL-DAC16ES

■ SIDE VIEW

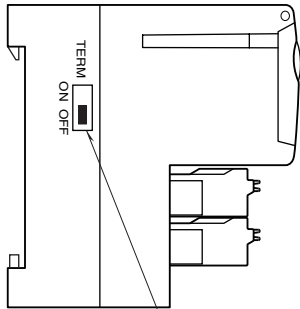

Terminating Resistor SW

■ FRONT VIEW

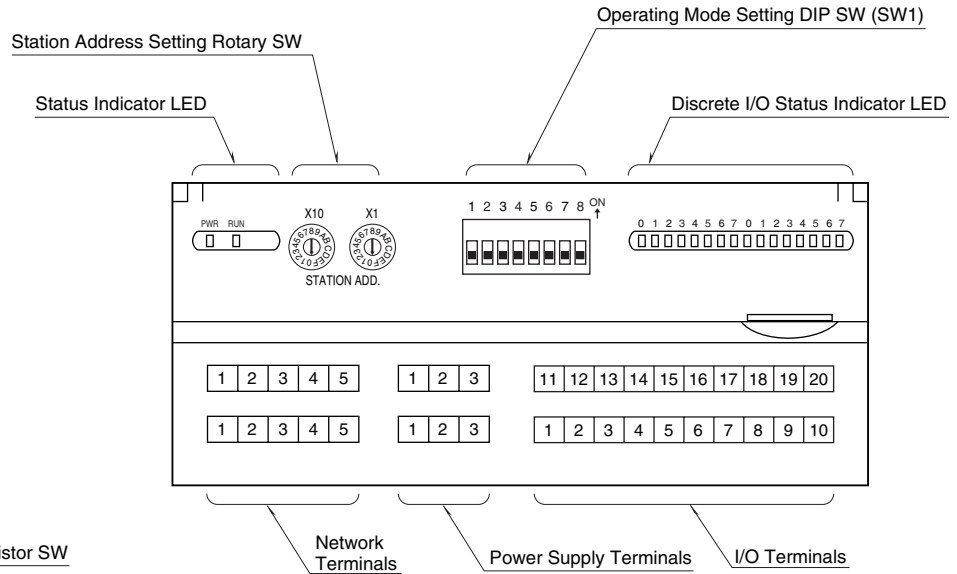

■ View of R7HL-PA4E

■ SIDE VIEW

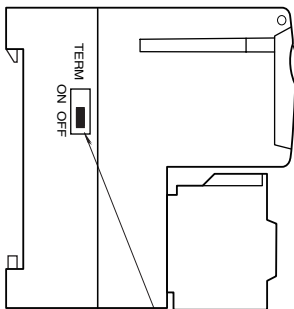

Terminating Resistor SW

■ FRONT VIEW

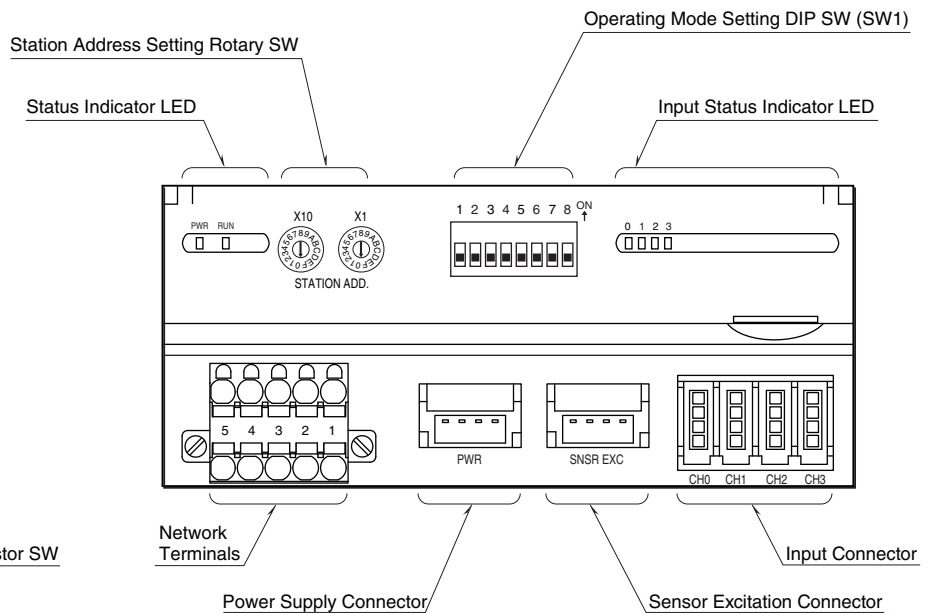

■ View of R7HL-PA25x

■ SIDE VIEW

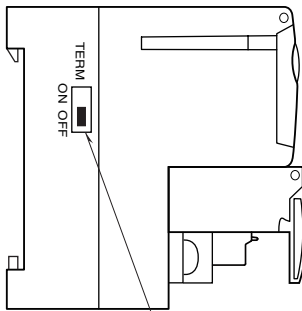

Terminating Resistor SW

■ FRONT VIEW

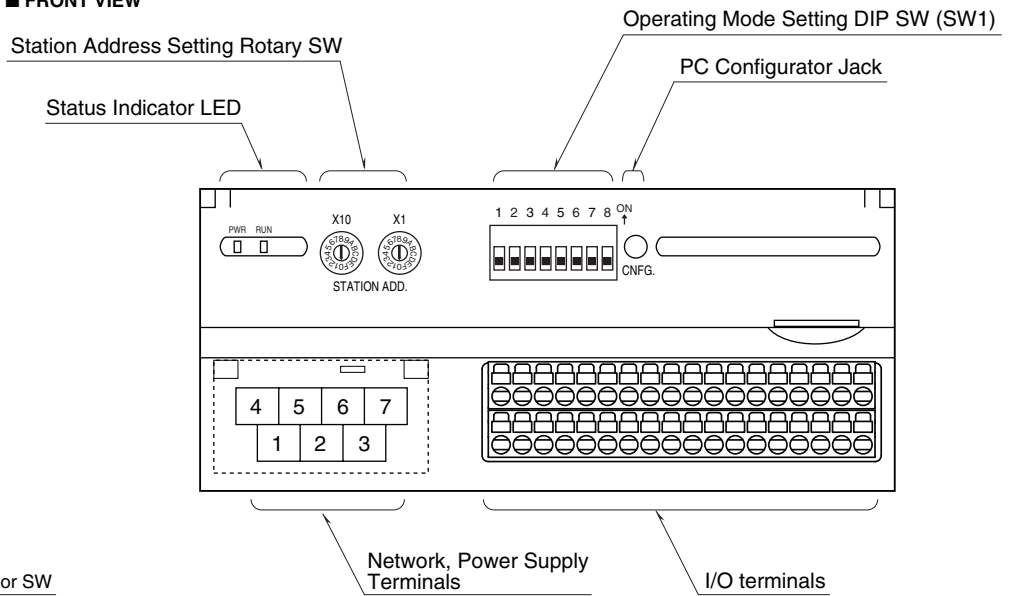

■ Basic View (except R7HL-DAC16ES, R7HL-PA4E and R7HL-PA25x)

■ SIDE VIEW

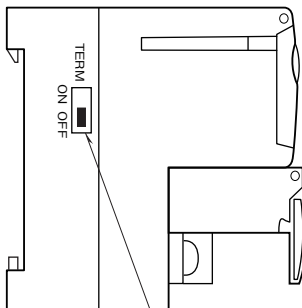

Terminating Resistor SW

■ FRONT VIEW

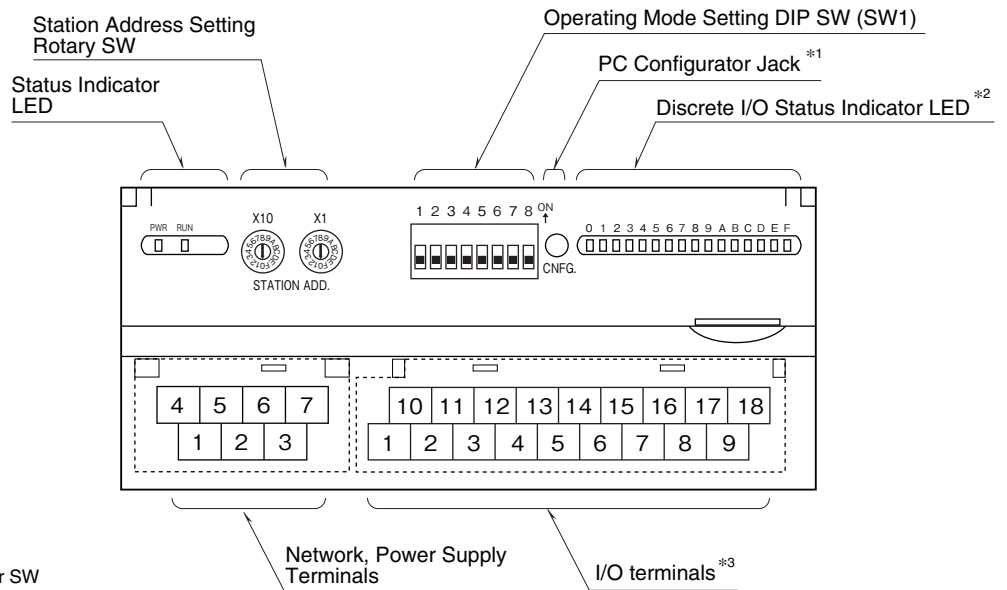

*1. Not available with discrete I/O modules.

*2. Not available with analog I/O modules except R7HL-LC2.
LED 8 through F are not available for 8-point discrete output modules.
Discrete output 7 LED is not available for R7HL-DAC15E.

*3. 10 screw terminals for analog output modules.

CONNECTION DIAGRAMS

■ I/O connection (Refer to each model terminal assignment)

• R7HL-PA4E

e-CON connector

Recommended cable connector: 37104-()-000FL (3M Company)

(The cable connector is not included in the package.)

Specify wire size instead of (); refer to the specifications of the product.)

• R7HL-DAC16ES

Tension clamp terminal block

Cable connector: FMC1,5/16-ST-3,5 (Phoenix Contact)

(The cable connector is included in the package.)

Applicable wire size: 0.2 – 1.5 mm²; stripped length 10 mm

Recommended solderless terminal

- AI0,25–10YE 0.25 mm² (Phoenix Contact)

- AI0,34–10TQ 0.34 mm² (Phoenix Contact)

- AI0,5–10WH 0.5 mm² (Phoenix Contact)

- AI0,75–10GY 0.75 mm² (Phoenix Contact)

- A1–10 1.0 mm² (Phoenix Contact)

- A1,5–10 1.5 mm² (Phoenix Contact)

• R7HL-PA2Sx

Tension clamp terminal block

Cable connector: FMC1,5/18-ST-3,5 (Phoenix Contact)

(The cable connector is included in the package.)

Applicable wire size: 0.2 – 1.5 mm²; stripped length 10 mm

Recommended solderless terminal

- AI0,25–10YE 0.25 mm² (Phoenix Contact)

- AI0,34–10TQ 0.34 mm² (Phoenix Contact)

- AI0,5–10WH 0.5 mm² (Phoenix Contact)

- AI0,75–10GY 0.75 mm² (Phoenix Contact)

- A1–10 1.0 mm² (Phoenix Contact)

- A1,5–10 1.5 mm² (Phoenix Contact)

• Except R7HL-DAC16ES, R7HL-PA4E and R7HL-PA2Sx

M3 separable screw terminals (torque 0.5 N·m)

Screw terminal material: Nickel-plated steel

Recommended solderless terminal:

Applicable wire size: 0.25 to 1.65 mm² (AWG 22 to 16)

Recommended manufacturer: Japan Solderless Terminal MFG.Co.Ltd, Nichifu Co.,Ltd

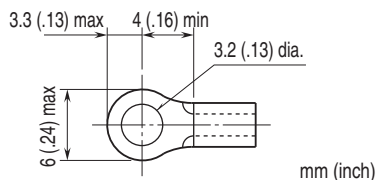

■ POWER SUPPLY (R7HL-DAC16ES)

Tension clamp terminal block

Cable connector: FMC1,5/16-ST-3,5 (Phoenix Contact)

(The cable connector is included in the package.)

Applicable wire size: 0.2 – 1.5 mm²; stripped length 10 mm

Recommended solderless terminal

- AI0,25–10YE 0.25 mm² (Phoenix Contact)
- AI0,34–10TQ 0.34 mm² (Phoenix Contact)
- AI0,5–10WH 0.5 mm² (Phoenix Contact)
- AI0,75–10GY 0.75 mm² (Phoenix Contact)
- A1–10 1.0 mm² (Phoenix Contact)
- A1,5–10 1.5 mm² (Phoenix Contact)

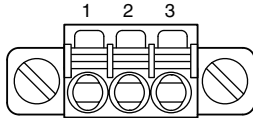

NO.	ID	FUNCTION, NOTES
1	+24V	Power input (24V DC)
2	0V	Power input (0V)
3	FG	FG

■ POWER SUPPLY, SENSOR EXCITATION (R7HL-PA4E)

Recommended cable connector: 38104-00x-000FL*² (3M)

(not included in the package)

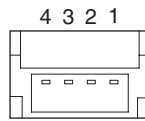

No.	ID (Power Supply)	ID (Sensor Excitation)
4	0V	GND
3	0V	GND
2	24 V DC	+24 V
1	24 V DC	+24 V

*2 'x' shows wire size. Refer to the manufacturer's catalog.

■ POWER SUPPLY, NETWORK (Except R7HL-DAC16ES and R7HL-PA4E)

M3 separable screw terminals (torque 0.5 N·m)

Screw terminal material: Nickel-plated steel

Recommended solderless terminal

• Communication cables

Applicable wire size: 0.2 to 0.5 mm² (AWG 26 to 22)

Recommended manufacturer: Japan Solderless Terminal MFG.Co.Ltd

• Power supply

Applicable wire size: 0.25 to 1.65 mm² (AWG 22 to 16)

Recommended manufacturer: Japan Solderless Terminal MFG. Co., Ltd. or Nichifu Co., Ltd.

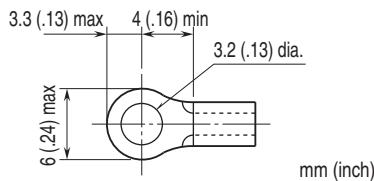

• Full-duplex communication

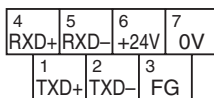

NO.	ID	FUNCTION, NOTES
1	TXD+	Network (slave, transmission +)
2	TXD-	Network (slave, transmission -)
3	FG	FG
4	RXD+	Network (master, transmission +)
5	RXD-	Network (master, transmission -)
6	+24V	Power input (24V DC)
7	0V	Power input (0V)

• Half-duplex communication

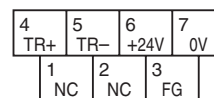

NO.	ID	FUNCTION, NOTES
1	NC	No connection
2	NC	No connection
3	FG	FG
4	TR+	Network
5	TR-	Network
6	+24V	Power input (24V DC)
7	0V	Power input (0V)

■ NETWORK

• R7HL-DAC16ES

Cable connector: FMC1,5/16-ST-3,5 (Phoenix Contact)

(The cable connector is included in the package.)

Applicable wire size: 0.2 – 1.5 mm²; stripped length 10 mm

Recommended solderless terminal

For ZHY262PS ZHT262PS and ZHY262PBA: TUB-0.5 (Japan solderless Terminal MFG. Co., Ltd.)

For ZHY221PS AI0,5-10WH (Phoenix Contact)

• Full-duplex communication

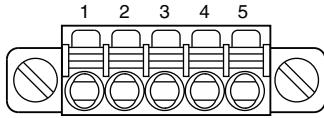

NO.	ID	FUNCTION, NOTES
1	RXD-	Network (master , transmission -)
2	RXD+	Network (master , transmission +)
3	TXD-	Network (slave , transmission -)
4	TXD+	Network (slave , transmission +)
5	SLD	Shield

• Half-duplex communication

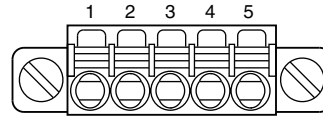

NO.	ID	FUNCTION, NOTES
1	NC	Unused
2	NC	Unused
3	TR-	Network
4	TR+	Network
5	SLD	Shield

• R7HL-PA4E

Cable connector: TFKC2,5/5-STF-5,08AU (Phoenix Contact) (included in the package)

Applicable wire size: 0.2 – 2.5 mm² stripped length 10mm

Recommended solderless terminal

For ZHY262PS, ZHT262PS and ZHY262PBA: TUB-0.5 (Japan Solderless Terminal MFG. Co., Ltd.)

For ZHY221PS: AI0,5-10WH (Phoenix Contact)

No.	ID (Full-duplex)	ID (Half-duplex)
5	RXD-	NC
4	RXD+	NC
3	TXD-	TR-
2	TXD+	TR+
1	SHIELD	SHIELD

■ MASTER CONNECTION

• Full-duplex communication

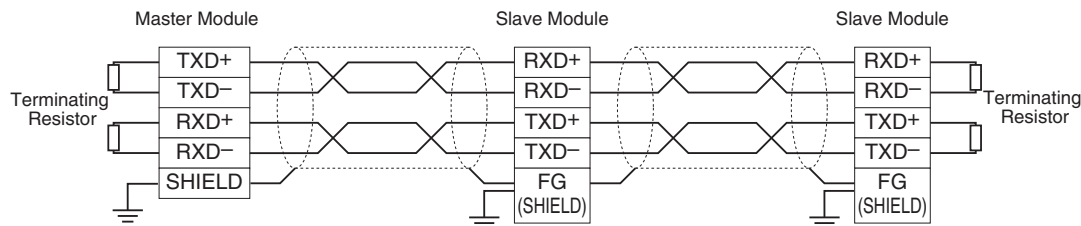

• Half-duplex communication

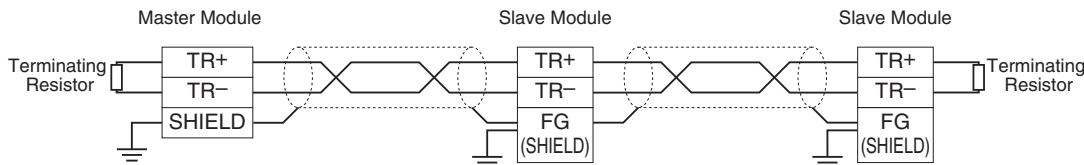

Note: Be sure to turn ON the switch of the terminating resistor located at both ends of the modules.

DATA CONVERSION

1. 0 - 100% DATA CONVERSION (R7HL-SV4, R7HL-SVF4, R7HL-YV2, R7HL-YS2)

Analog input data is converted into digital representations of 0 – 100% proportional to each scaled range. The converted % values are multiplied by 100 and expressed in 16 bits.

Overrange input is possible from -15 to +115% of the nominal range. When the signal exceeds the limit, the data is fixed at -15% or +115% respectively. Negative value is represented in 2's complements.

• Input Range 0 – 5 V DC

Input Value	Input %	Converted Data, Decimal	Converted Data, Hex
≤ -0.75 V	-15%	-1500	FA24
0 V	0%	0	0
5 V	100%	10000	2710
≥ 5.75 V	115%	11500	2CEC

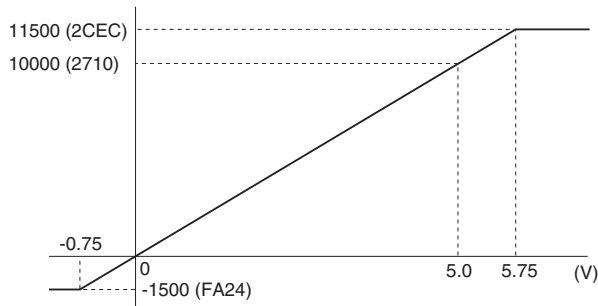

Analog output is converted in the reverse order of the input data. The output range 0 – 5 V DC is expressed as 10000 at 5.0 V (100%) and 0 at 0 V (0%).

2. 12 BITS DATA CONVERSION (R7HL-SVF8NL, R7HL-YV4L)

The analog data for input is converted to 12 bits digital value (0 to 4095) by each input range.

Input range refers range of the input, when input exceeds this range it is fixed to 0 or 4095.

For analog output, it is converted in reverse of input.

When output range is 0 to 5 V DC, output is 5.0 V (100%) for '4095'; 0 V (0%) for '0'.

3. ENGINEERING UNIT CONVERSION (R7HL-TS4, R7HL-RS4)

Engineering unit value °C or K is multiplied by 10 and expressed in 16 bits. °F data is represented in engineering unit value, without multiplication. Negative value is represented in 2's complements.

• Input TYPE K Thermocouple

Input Value	Converted Data, Decimal	Converted Data, Hex
≤ -272°C	-2720	F560
-150°C	-1500	FA24
1370°C	13700	3584
≥ 1472°C	14720	3980

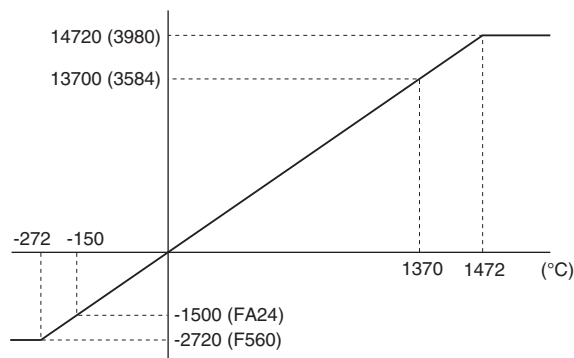

4. ENCODER INPUT

Encoder input data is converted into digital representations of 0 – 100% proportional to each scaled range. The converted % values are multiplied by 100 and expressed in 16 bits. Overrange input is possible from -15 to +115% of the nominal range. When the signal exceeds the limit, the data is fixed at -15% or +115% respectively.

Input Range 0 – 100 kHz

Input Value	Input %	Converted Data, Decimal	Converted Data, Hex
-130kHz	-15%	-1500	FA24
-100kHz	0%	0	0
0kHz	50%	5000	1388
100kHz	100%	10000	2710
130kHz	115%	11500	2CEC

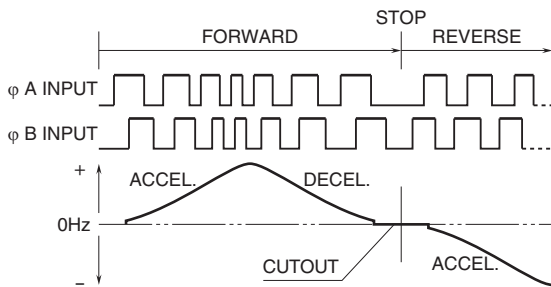
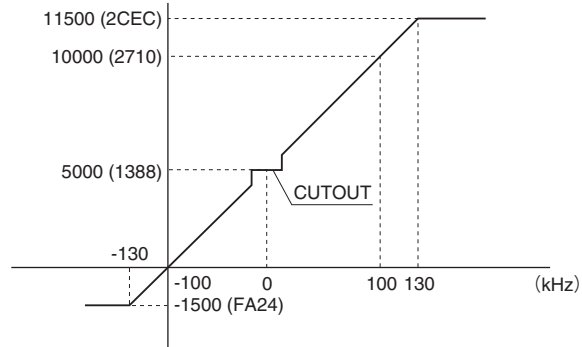

I/O DATA DESCRIPTIONS

Scaling of analog input, analog output and encoder input (speed) is configurable with the configurator software (model: R7CON). Refer to the software manual for details.

ANALOG INPUT (EXCEPT R7HL-SVF8NL) *1

• Di

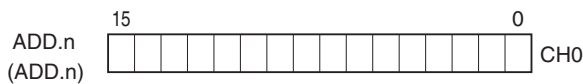

• Do

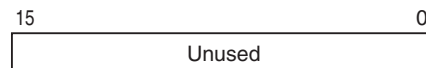
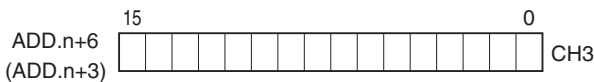
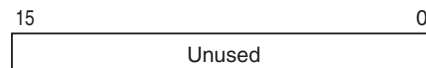
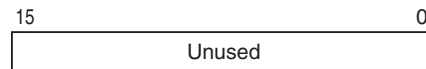
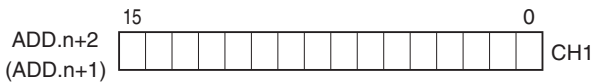
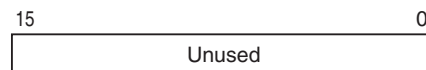

The data is 16-bit binary.

Negative value is represented in 2's complements.

Address in parentheses are for half-duplex mode.

*1. Scaling is available with Configurator Software (model: R7CON).

Refer to the Configurator Software users manual for detail.

■ ANALOG INPUT (R7HL-SVF8NL)

• Di

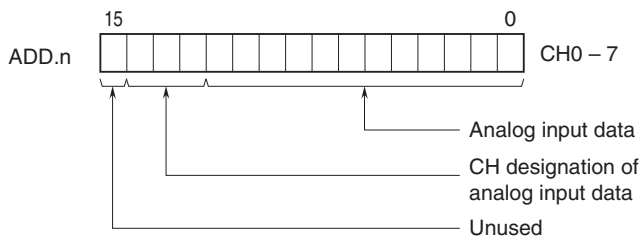

• Do

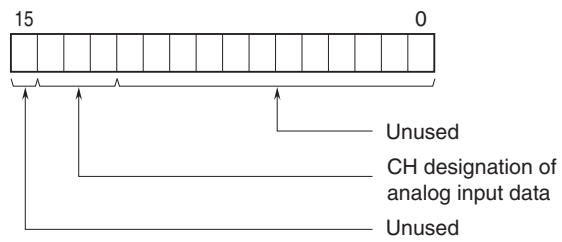

The data is 12-bit binary.

Divided by 8 times scan, 8 points input data is transferred by using CH designation bit.

■ ANALOG OUTPUT (EXCEPT R7HL-YV4L) *1

• Di

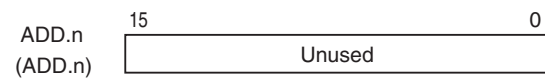

• Do

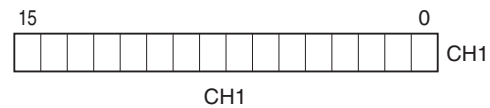
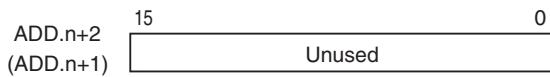

The data is 16-bit binary.

Negative value is represented in 2's complements.

Address in parentheses are for half-duplex mode.

*1. Scaling is available with Configurator Software (model: R7CON).

Refer to the Configurator Software users manual for detail.

■ ANALOG OUTPUT (R7HL-YV4L)

• Di

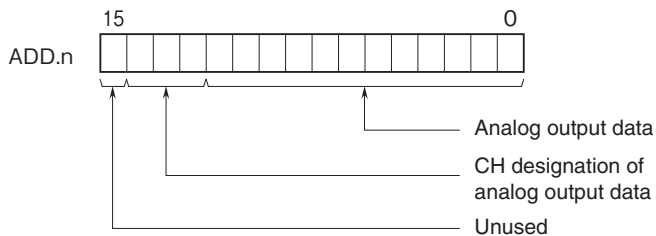

• Do

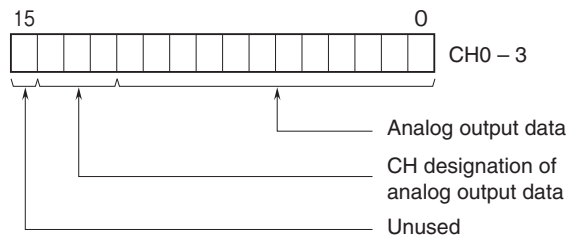

The data is 12-bit binary.

Divided by 4 times scan, 4 points output data is transferred by using CH designation bit.

For Di, the data written to Do is echoed back.

■ DISCRETE INPUT

• Di

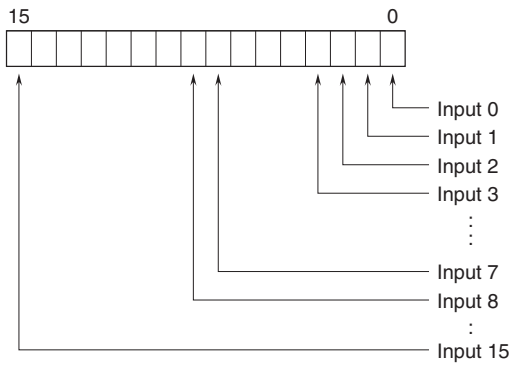

• Do

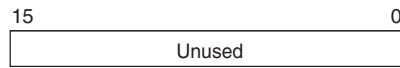

■ DISCRETE OUTPUT

• Di

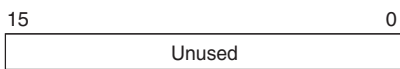

• Do

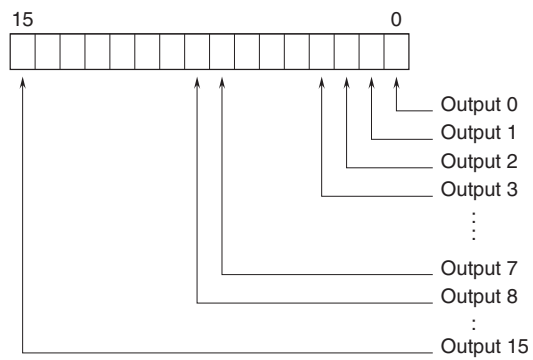

■ DISCRETE I/O (16 points)

• Di

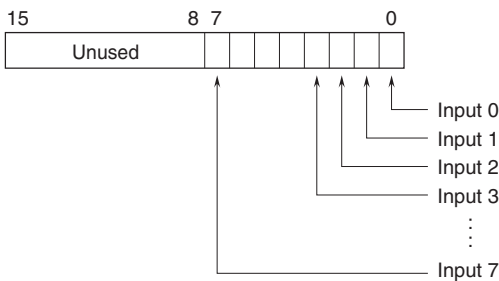

• Do

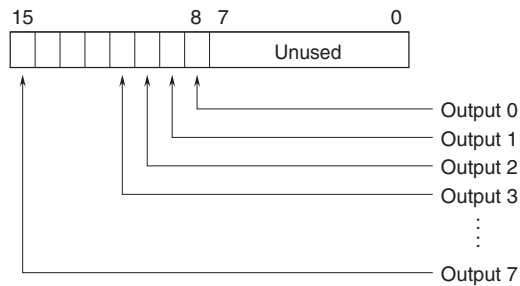

■ DISCRETE I/O (32 points)

• Di

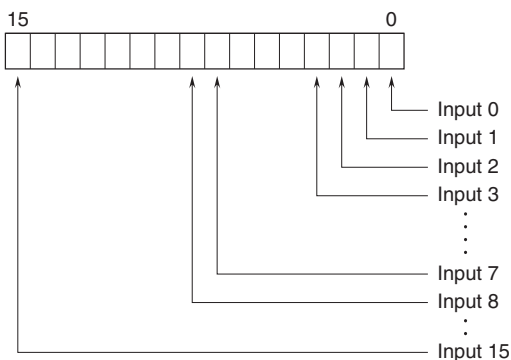

• Do

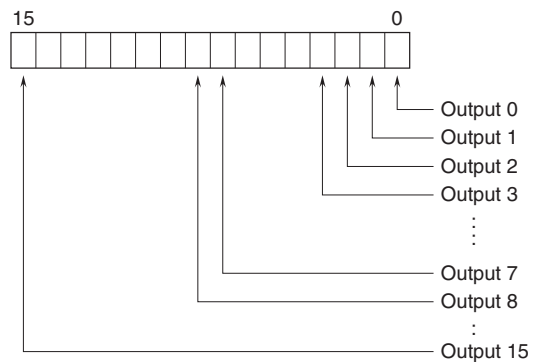

0: OFF
1: ON

■ RELAY CONTACT OUTPUT

• Di

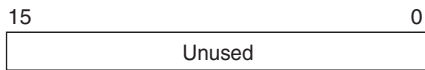

0: OFF
1: ON

• Do

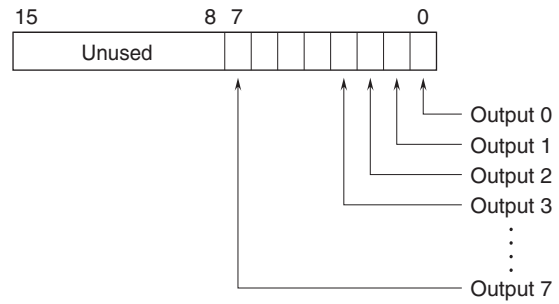

■ TOTALIZED PULSE INPUT (R7HL-PA4E)

• Di

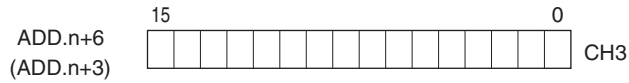
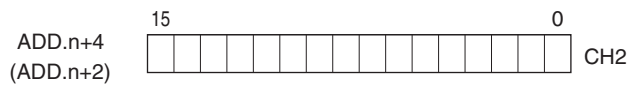
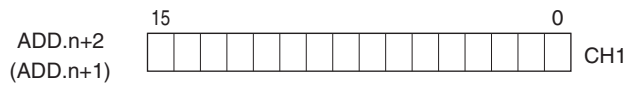
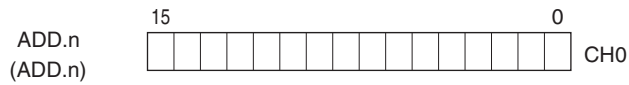

• Do

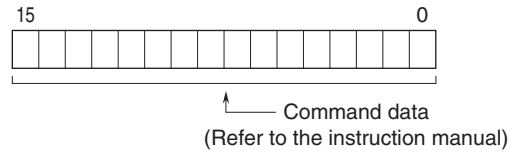
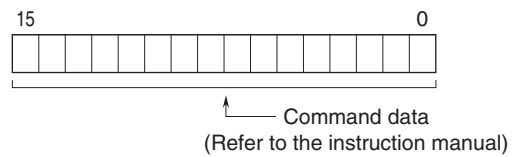
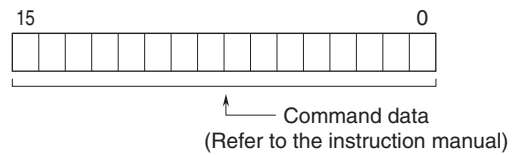
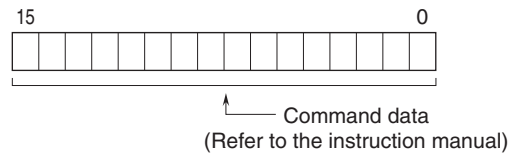

The data is 16-bit binary.
Addresses in parentheses are for half-duplex mode.

■ POSITION DATA (Data allocation: 2 for each channel, total 4) (R7HL-PA2Sx)

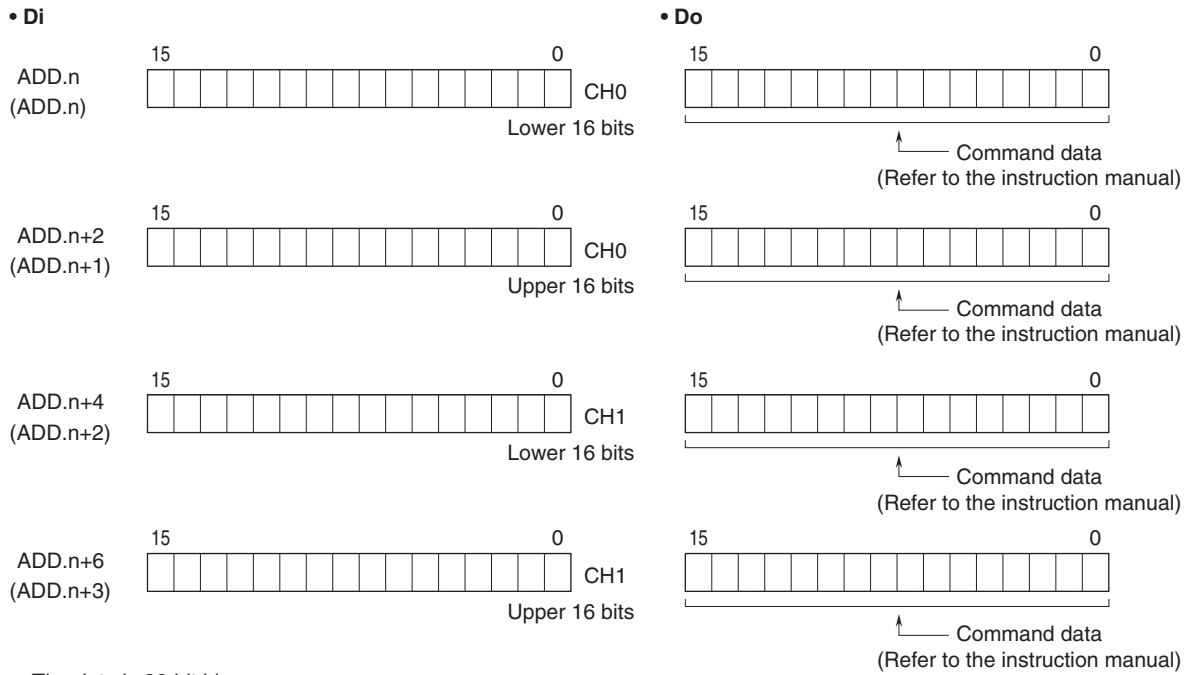

The data is 32-bit binary.
Addresses in parentheses are for half-duplex mode.

■ SPEED DATA (Data allocation: 1 for each channel, total 2) (R7HL-PA2Sx)

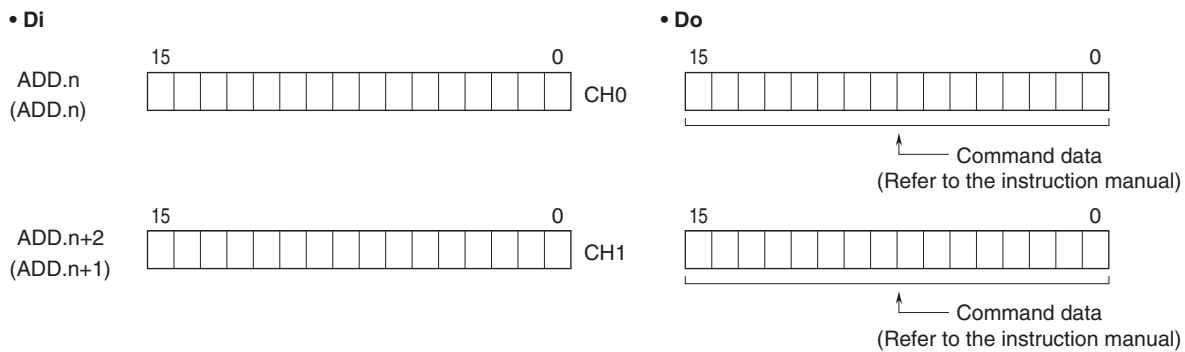

Speed data is described in 16-bit binary, which express the frequency range specified with SW1-2 to 1-4 as 10000.
Addresses for half-duplex are in parentheses.

■ STRAIN GAUGE INPUT

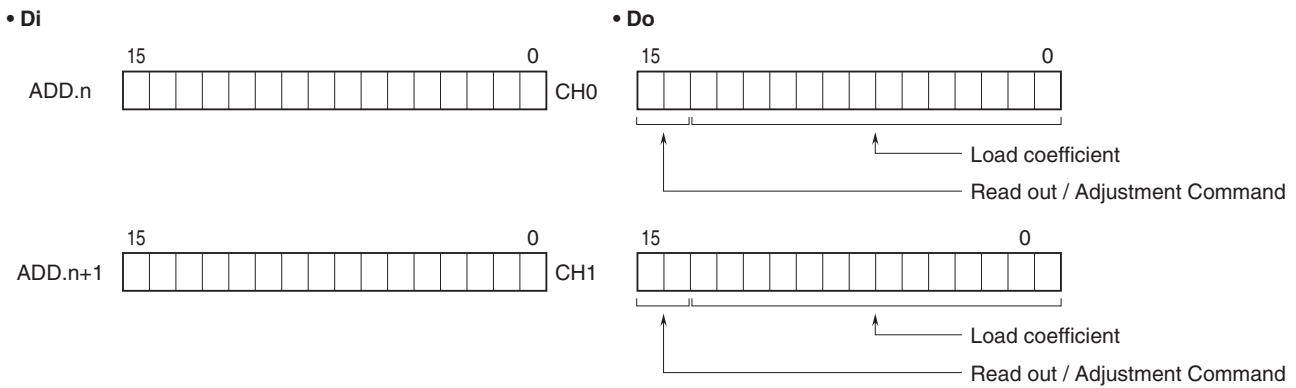

The value in the input range corresponding to -10000 to $+10000$ is represented in 16 bits binary data. Address allocation for full-duplex and half-duplex communication is same.

■ LOAD COEFFICIENT

It is available to configure the load coefficient to 0 or the range of 1000 (10.00%) to 10000 (100.00%). The load coefficient: 0 is equivalent to 100.00%.

■ READ OUT / ADJUSTMENT COMMAND

Read out command and adjustment command for data are allocated to bit 14 and 15. The details of the commands are shown in the table below.

COMMAND	BIT 15	BIT 14
Read out data	0	0
Auto zero adjustment	0	1
Zero adjustment	1	0
Span adjustment	1	1

EXTERNAL DIMENSIONS unit: mm [inch]

■ DISCRETE I/O MODULE (Except R7HL-DAC16ES), ANALOG INPUT MODULE

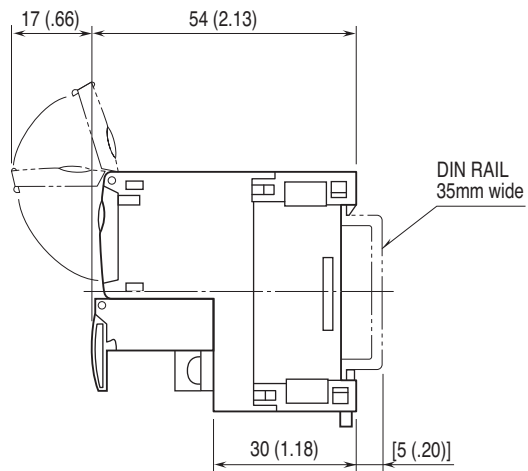
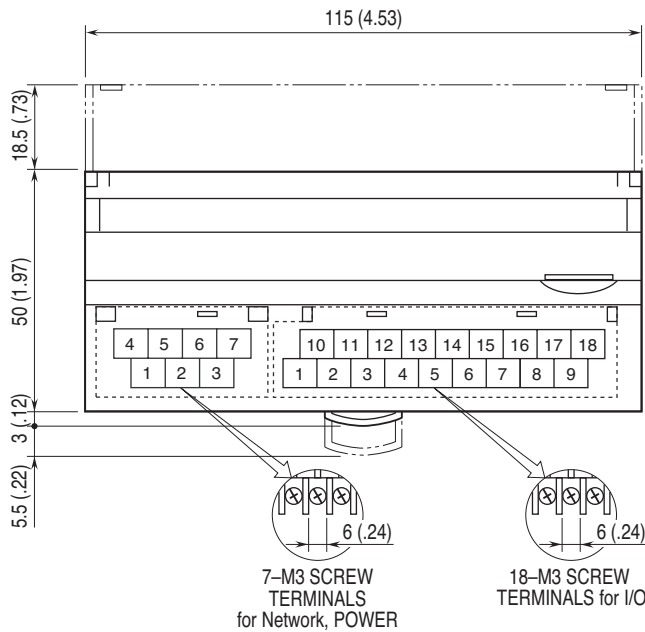

• For R7HL-TS4

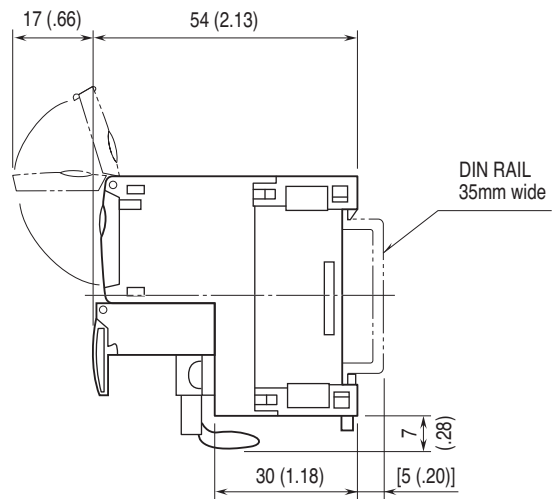

■ DISCRETE I/O MODULE (R7HL-DAC16ES)

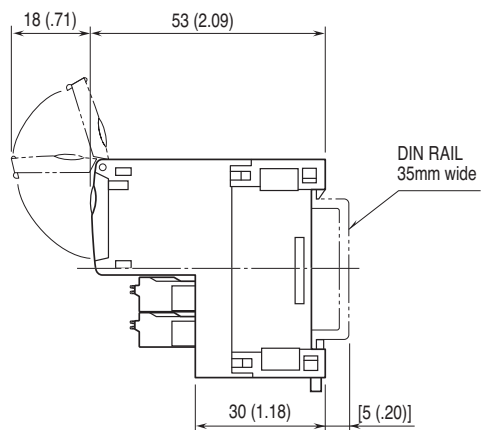
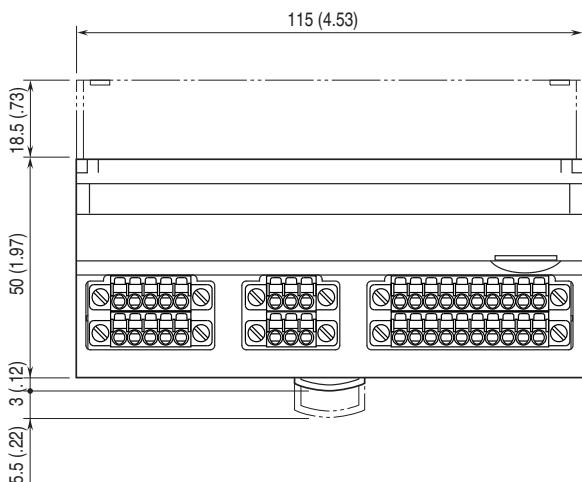

■ ANALOG OUTPUT MODULE

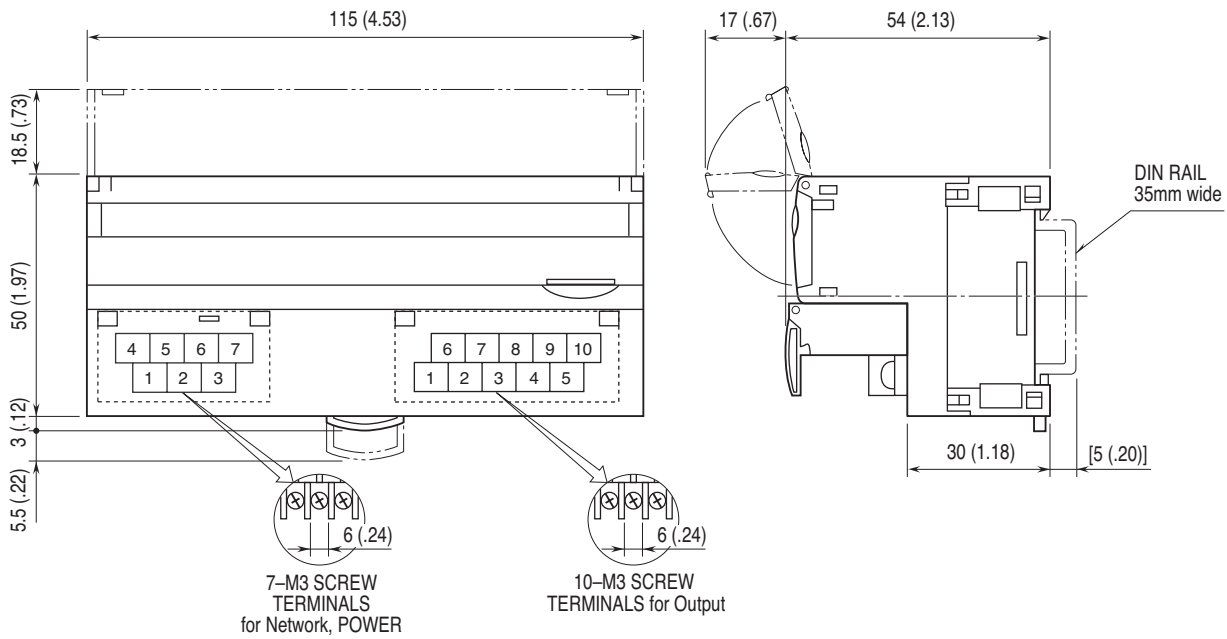

■ TOTALIZED PULSE INPUT MODULE

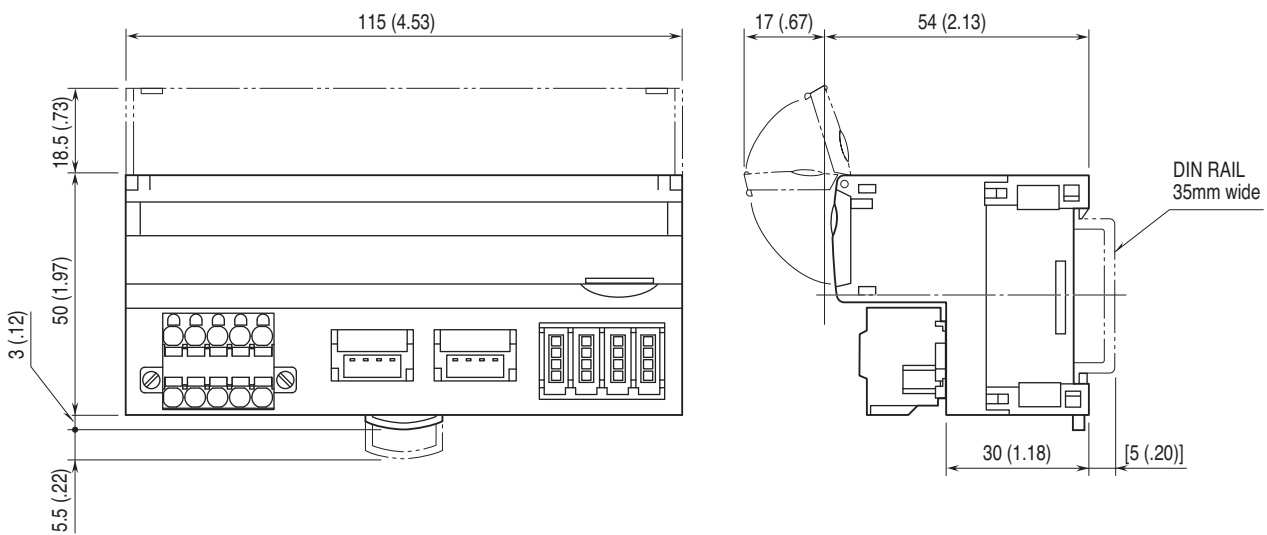

■ ENCODER INPUT MODULE

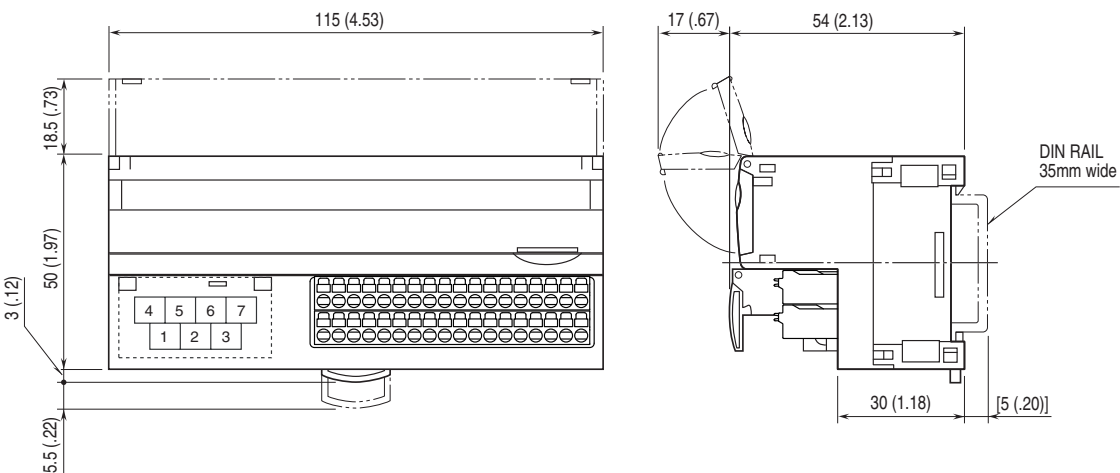

DISCRETE INPUT MODULE, 16 points

MODEL: R7HL-DA16

SPECIFICATIONS

Common: Positive or negative common (NPN/PNP) per 16 points
Number of I/O: Input, 16 points
Maximum inputs applicable at once: No limit (at 24 V DC)
Input status indicator: LED turns ON with contact ON
Isolation: Input to HLS to power input to FG
Data allocation: 1
Rated input voltage: 24 V DC $\pm 10\%$; ripple 5 %p-p max.
ON voltage / current: ≥ 15 V DC (input - COM) / ≥ 3.5 mA
OFF voltage / current: ≤ 5 V DC (input - COM) / ≤ 1 mA
Input current: ≤ 5.5 mA per point at 24 V DC
Input resistance: Approx. 4.4 k Ω
ON delay: ≤ 0.5 msec.
OFF delay: ≤ 0.5 msec.

OPERATING MODE SETTING

(*) Factory setting
 Caution ! - SW1-1 through 1-7 are unused. Be sure to turn off unused ones.

• Transfer Rate (SW1-8)

SW1-8	Transfer rate
OFF	12Mbps (*)
ON	6Mbps

TERMINAL ASSIGNMENTS

10	11	12	13	14	15	16	17	18
COM	X1	X3	X5	X7	X9	XB	XD	XF
1	2	3	4	5	6	7	8	9
COM	X0	X2	X4	X6	X8	XA	XC	XE

NO.	ID	FUNCTION	NO.	ID	FUNCTION
1	COM	Common	10	COM	Common
2	X0	Input 0	11	X1	Input 1
3	X2	Input 2	12	X3	Input 3
4	X4	Input 4	13	X5	Input 5
5	X6	Input 6	14	X7	Input 7
6	X8	Input 8	15	X9	Input 9
7	XA	Input 10	16	XB	Input 11
8	XC	Input 12	17	XD	Input 13
9	XE	Input 14	18	XF	Input 15

CIRCUIT DIAGRAM

Note: In order to improve EMC performance, bond the FG terminal to ground.

Caution: FG terminal is NOT a protective conductor terminal.

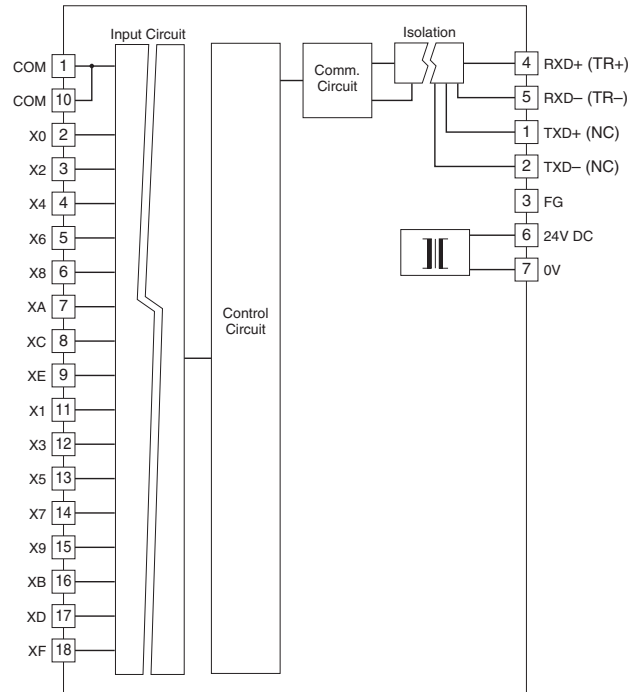

Note: Terminal numbers in parentheses are for half-duplex communication model.

■ Input Circuit

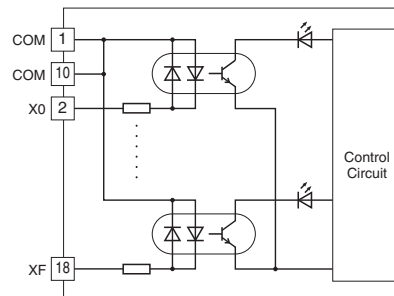

■ Input Connection Examples

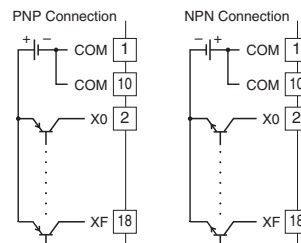

NPN TRANSISTOR OUTPUT MODULE, 16 points

MODEL: R7HL-DC16A

SPECIFICATIONS

Common: Negative common (NPN) per 16 points
Number of I/O: Output, 16 points
Maximum outputs applicable at once: No limit (at 24 V DC)
Output status indicator: LED turns ON with contact ON
Isolation: Output to HLS to power input to FG
Data allocation: 1
Rated load voltage: 10.8 – 26.4 V DC
Rated output current: 0.25 A per point, 2.0 A per common
Residual voltage: ≤ 1.2 V
Leakage current: ≤ 0.1 mA
ON delay: ≤ 0.2 msec.
OFF delay: ≤ 0.5 msec.
 (When driving an inductive load, connect a diode in parallel with the load.)

OPERATING MODE SETTING

(*) Factory setting

Caution ! - SW1-1 through 1-6 are unused. Be sure to turn off unused ones.

• Output at the Loss of Communication (SW1-7)

SW1-7	Output at the loss of communication
OFF	Hold the output (*) (maintains the last data received normally)
ON	Reset the output (turned off)

• Transfer Rate (SW1-8)

SW1-8	Transfer rate
OFF	12Mbps (*)
ON	6Mbps

TERMINAL ASSIGNMENTS

10	11	12	13	14	15	16	17	18
+24V	Y1	Y3	Y5	Y7	Y9	YB	YD	YF
1	2	3	4	5	6	7	8	9
0V	Y0	Y2	Y4	Y6	Y8	YA	YC	YE

NO.	ID	FUNCTION	NO.	ID	FUNCTION
1	0 V	0 V (common)	10	+24 V	24 V DC
2	Y0	Output 0	11	Y1	Output 1
3	Y2	Output 2	12	Y3	Output 3
4	Y4	Output 4	13	Y5	Output 5
5	Y6	Output 6	14	Y7	Output 7
6	Y8	Output 8	15	Y9	Output 9
7	YA	Output 10	16	YB	Output 11
8	YC	Output 12	17	YD	Output 13
9	YE	Output 14	18	YF	Output 15

CIRCUIT DIAGRAM

Note: In order to improve EMC performance, bond the FG terminal to ground.

Caution: FG terminal is NOT a protective conductor terminal.

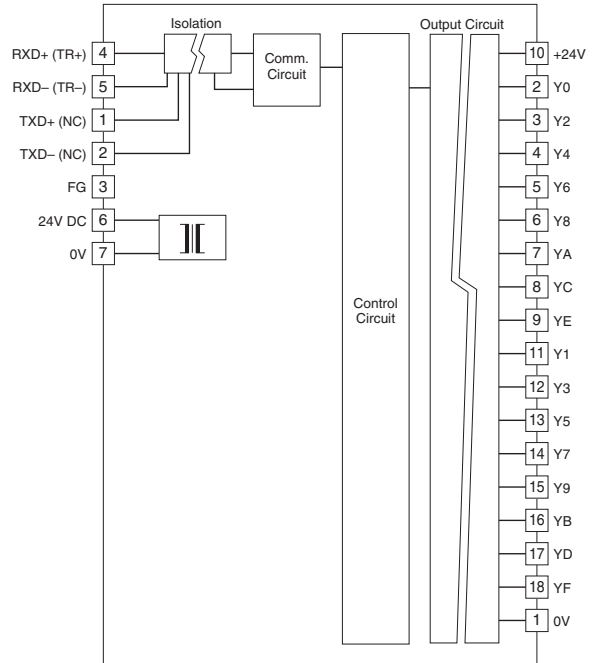

Note: Terminal numbers in parentheses are for half-duplex communication model.

■ Output Circuit

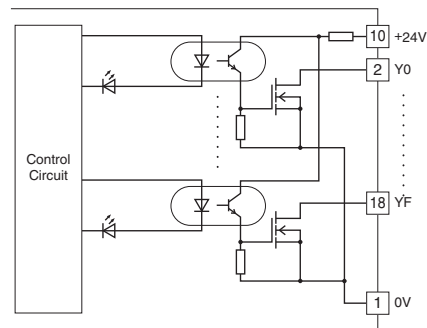

■ Output Connection Example

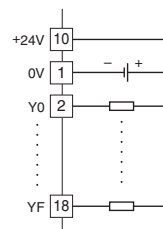

PNP TRANSISTOR OUTPUT MODULE, 16 points

MODEL: R7HL-DC16B

SPECIFICATIONS

Common: Positive common (PNP) per 16 points
Number of I/O: Output, 16 points
Maximum outputs applicable at once: No limit (at 24 V DC)
Output status indicator: LED turns ON with contact ON
Isolation: Output to HLS to power input to FG
Data allocation: 1
Rated load voltage: 24 V DC $\pm 10\%$
Rated output current: 0.25 A per point, 2.0 A per common
Residual voltage: ≤ 1.2 V
Leakage current: ≤ 0.1 mA
ON delay: ≤ 0.2 msec.
OFF delay: ≤ 0.5 msec.
 (When driving an inductive load, connect a diode in parallel with the load.)

OPERATING MODE SETTING

(*) Factory setting

Caution ! - SW1-1 through 1-6 are unused. Be sure to turn off unused ones.

• Output at the Loss of Communication (SW1-7)

SW1-7	Output at the loss of communication
OFF	Hold the output (*) (maintains the last data received normally)
ON	Reset the output (turned off)

• Transfer Rate (SW1-8)

SW1-8	Transfer rate
OFF	12Mbps (*)
ON	6Mbps

TERMINAL ASSIGNMENTS

10	11	12	13	14	15	16	17	18
+24V	Y1	Y3	Y5	Y7	Y9	YB	YD	YF
1	2	3	4	5	6	7	8	9
0V	Y0	Y2	Y4	Y6	Y8	YA	YC	YE

NO.	ID	FUNCTION	NO.	ID	FUNCTION
1	0 V	0 V	10	+24 V	24 V DC (common)
2	Y0	Output 0	11	Y1	Output 1
3	Y2	Output 2	12	Y3	Output 3
4	Y4	Output 4	13	Y5	Output 5
5	Y6	Output 6	14	Y7	Output 7
6	Y8	Output 8	15	Y9	Output 9
7	YA	Output 10	16	YB	Output 11
8	YC	Output 12	17	YD	Output 13
9	YE	Output 14	18	YF	Output 15

CIRCUIT DIAGRAM

Note: In order to improve EMC performance, bond the FG terminal to ground.

Caution: FG terminal is NOT a protective conductor terminal.

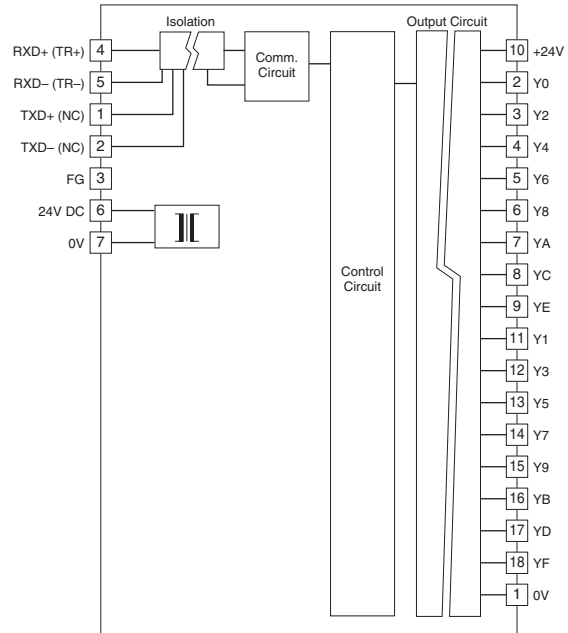

Note: Terminal numbers in parentheses are for half-duplex communication model.

■ Output Circuit

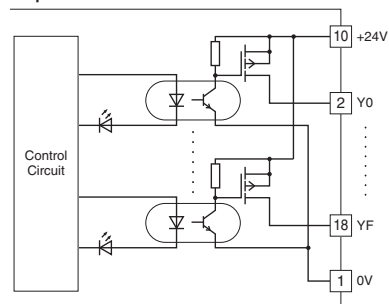

■ Output Connection Example

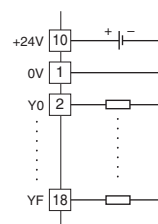

DISCRETE INPUT, 8 points & NPN TRANSISTOR OUTPUT, 7 points MODULE

(independent I/O common)

MODEL: R7HL-DAC15E

SPECIFICATIONS

COMMON SPECIFICATIONS

Input common: Positive or negative (NPN/PNP) per 8 points

Output common: Negative common (NPN) per 7 points

Number of I/O: Input, 8 points; Output, 7 points

Maximum I/O applicable at once: No limit (at 24 V DC)

I/O status indicator: LED turns ON with contact ON

Isolation: Input to output to HLS to power input to FG

Data allocation: 1

INPUT

Rated input voltage: 24 V DC $\pm 10\%$; ripple 5 %p-p max.

ON voltage/current: ≥ 15 V DC (input-COM) / ≥ 3.5 mA

OFF voltage/current: ≤ 5 V DC (input-COM) / ≤ 1 mA

Input current: ≤ 5.5 mA per point at 24 V DC

Input resistance: Approx. 4.4 k Ω

ON delay: ≤ 0.5 msec.

OFF delay: ≤ 0.5 msec.

OUTPUT

Rated load voltage: 24 V DC $\pm 10\%$

Rated output current: 0.25 A per point, 1.75 A per common

Residual voltage: ≤ 1.2 V

Leakage current: ≤ 0.1 mA

ON delay: ≤ 0.2 msec.

OFF delay: ≤ 0.5 msec.

(When driving an inductive load, connect a diode in parallel with the load.)

OPERATING MODE SETTING

(*) Factory setting

Caution ! - SW1-1 through 1-6 are unused. Be sure to turn off unused ones.

Output at the Loss of Communication (SW1-7)

SW1-7	Output at the loss of communication
OFF	Hold the output (*) (maintains the last data received normally)
ON	Reset the output (turned off)

Transfer Rate (SW1-8)

SW1-8	Transfer rate
OFF	12Mbps (*)
ON	6Mbps

TERMINAL ASSIGNMENTS

10	11	12	13	14	15	16	17	18
X0	X2	X4	X6	+24V	Y0	Y2	Y4	Y6
1	2	3	4	5	6	7	8	9
COM	X1	X3	X5	X7	0V	Y1	Y3	Y5

NO.	ID	FUNCTION	NO.	ID	FUNCTION
1	COM	Common	10	X0	Input 0
2	X1	Input 1	11	X2	Input 2
3	X3	Input 3	12	X4	Input 4
4	X5	Input 5	13	X6	Input 6
5	X7	Input 7	14	+24V	24V DC
6	0V	0V (Output common)	15	Y0	Output 0
7	Y1	Output 1	16	Y2	Output 2
8	Y3	Output 3	17	Y4	Output 4
9	Y5	Output 5	18	Y6	Output 6

CIRCUIT DIAGRAM

Note: In order to improve EMC performance, bond the FG terminal to ground.

Caution: FG terminal is NOT a protective conductor terminal.

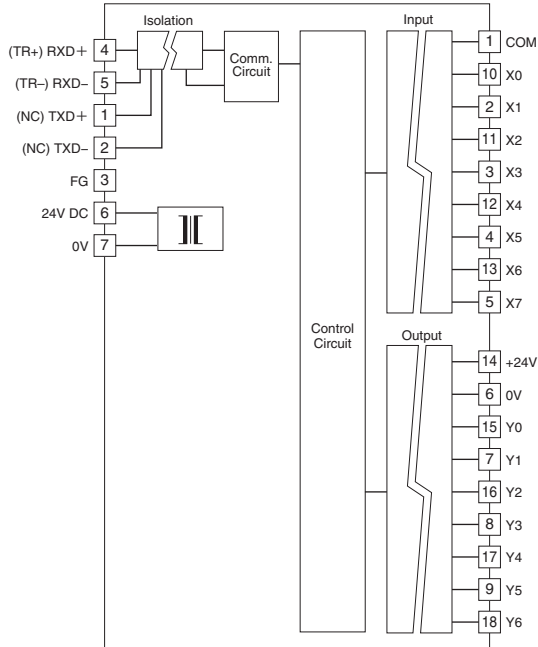

Note: Terminal numbers in parentheses are for half-duplex communication model.

Input Circuit

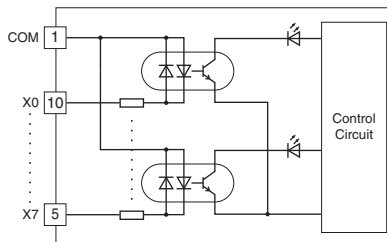

Output Circuit

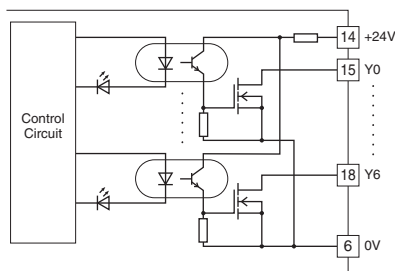

I/O Connection Example

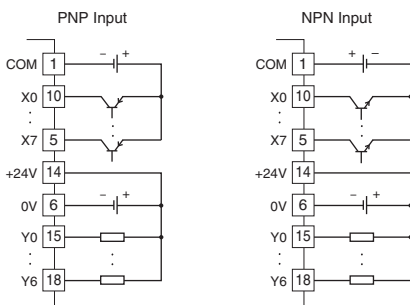

**PNP DISCRETE INPUT &
NPN TRANSISTOR OUTPUT MODULE, 8 points each**

MODEL: R7HL-DAC16A

TERMINAL ASSIGNMENTS

10 +24V	11 X1	12 X3	13 X5	14 X7	15 Y1	16 Y3	17 Y5	18 Y7
1 COM	2 X0	3 X2	4 X4	5 X6	6 Y0	7 Y2	8 Y4	9 Y6

SPECIFICATIONS

COMMON SPECIFICATIONS

Common: Negative common per 16 points
Number of I/O: Input, 8 points; Output, 8 points
Maximum I/O applicable at once: No limit (at 24 V DC)
I/O status indicator: LED turns ON with contact ON
Isolation: Input or output to HLS to power input to FG
Data allocation: 1

INPUT

Rated input voltage: 24 V DC $\pm 10\%$; ripple 5 %p-p max.
ON voltage/current: ≥ 15 V DC (input-COM) / ≥ 3.5 mA
OFF voltage/current: ≤ 5 V DC (input-COM) / ≤ 1 mA
Input current: ≤ 5.5 mA per point at 24 V DC
Input resistance: Approx. 4.4 k Ω
ON delay: ≤ 0.5 msec.
OFF delay: ≤ 0.5 msec.

OUTPUT

Rated load voltage: 24 V DC $\pm 10\%$
Rated output current: 0.25 A per point, 2.0 A per common
Residual voltage: ≤ 1.2 V
Leakage current: ≤ 0.1 mA
ON delay: ≤ 0.2 msec.
OFF delay: ≤ 0.5 msec.
 (When driving an inductive load, connect a diode in parallel with the load.)

NO.	ID	FUNCTION	NO.	ID	FUNCTION
1	COM	Common	10	+24V	24V DC
2	X0	Input 0	11	X1	Input 1
3	X2	Input 2	12	X3	Input 3
4	X4	Input 4	13	X5	Input 5
5	X6	Input 6	14	X7	Input 7
6	Y0	Output 0	15	Y1	Output 1
7	Y2	Output 2	16	Y3	Output 3
8	Y4	Output 4	17	Y5	Output 5
9	Y6	Output 6	18	Y7	Output 7

OPERATING MODE SETTING

(*) Factory setting

Caution ! - SW1-1 through 1-6 are unused. Be sure to turn off unused ones.

Output at the Loss of Communication (SW1-7)

SW1-7	Output at the loss of communication
OFF	Hold the output (*) (maintains the last data received normally)
ON	Reset the output (turned off)

Transfer Rate (SW1-8)

SW1-8	Transfer rate
OFF	12Mbps (*)
ON	6Mbps

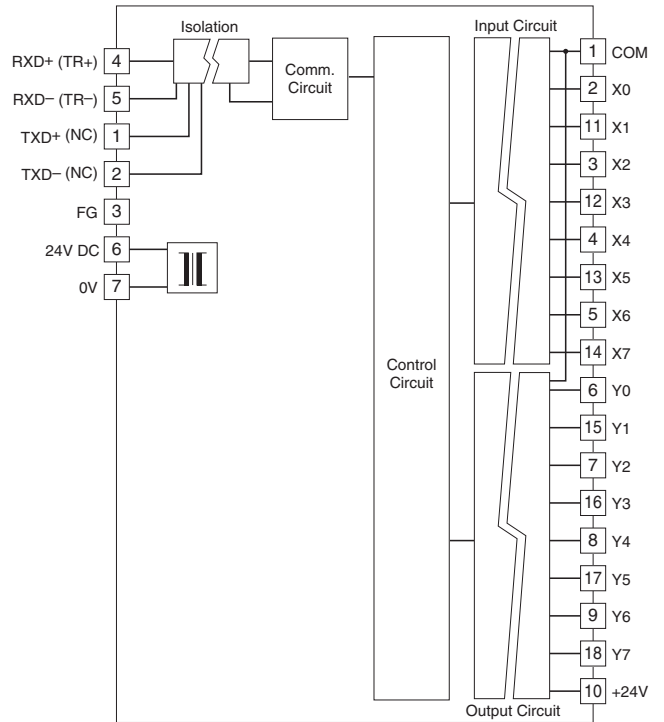

Note: Terminal numbers in parentheses are for half-duplex communication model.

CIRCUIT DIAGRAM

Note: In order to improve EMC performance, bond the FG terminal to ground.

Caution: FG terminal is NOT a protective conductor terminal.

Input Circuit

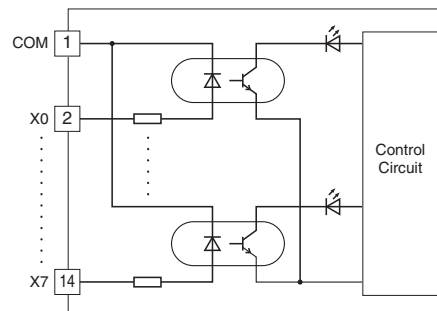

Output Circuit

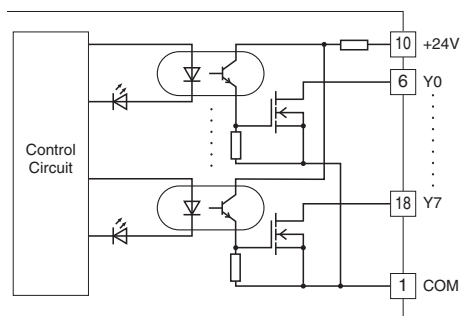

I/O Connection Example

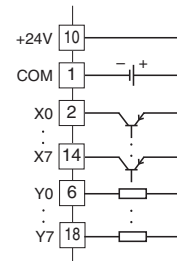

**NPN DISCRETE INPUT &
PNP TRANSISTOR OUTPUT MODULE, 8 points each**

MODEL: R7HL-DAC16B

TERMINAL ASSIGNMENTS

10 +24V	11 X1	12 X3	13 X5	14 X7	15 Y1	16 Y3	17 Y5	18 Y7
1 COM	2 X0	3 X2	4 X4	5 X6	6 Y0	7 Y2	8 Y4	9 Y6

SPECIFICATIONS

■ COMMON SPECIFICATIONS

Common: Positive common per 16 points
Number of I/O: Input, 8 points; Output, 8 points
Maximum I/O applicable at once: No limit (at 24 V DC)
I/O status indicator: LED turns ON with contact ON
Isolation: Input or output to HLS to power input to FG
Data allocation: 1

■ INPUT

Rated input voltage: 24 V DC $\pm 10\%$; ripple 5 %p-p max.
ON voltage/current: ≥ 15 V DC (input-COM) / ≥ 3.5 mA
OFF voltage/current: ≤ 5 V DC (input-COM) / ≤ 1 mA
Input current: ≤ 5.5 mA per point at 24 V DC
Input resistance: Approx. 4.4 k Ω
ON delay: ≤ 0.5 msec.
OFF delay: ≤ 0.5 msec.

■ OUTPUT

Rated load voltage: 24 V DC $\pm 10\%$
Rated output current: 0.25 A per point, 2.0 A per common
Residual voltage: ≤ 1.2 V
Leakage current: ≤ 0.1 mA
ON delay: ≤ 0.2 msec.
OFF delay: ≤ 0.5 msec.
 (When driving an inductive load, connect a diode in parallel with the load.)

NO.	ID	FUNCTION	NO.	ID	FUNCTION
1	COM	Common	10	+24V	24V DC
2	X0	Input 0	11	X1	Input 1
3	X2	Input 2	12	X3	Input 3
4	X4	Input 4	13	X5	Input 5
5	X6	Input 6	14	X7	Input 7
6	Y0	Output 0	15	Y1	Output 1
7	Y2	Output 2	16	Y3	Output 3
8	Y4	Output 4	17	Y5	Output 5
9	Y6	Output 6	18	Y7	Output 7

OPERATING MODE SETTING

(*) Factory setting
 Caution ! - SW1-1 through 1-6 are unused. Be sure to turn off unused ones.

• Output at the Loss of Communication (SW1-7)

SW1-7	Output at the loss of communication
OFF	Hold the output (*) (maintains the last data received normally)
ON	Reset the output (turned off)

• Transfer Rate (SW1-8)

SW1-8	Transfer rate
OFF	12Mbps (*)
ON	6Mbps

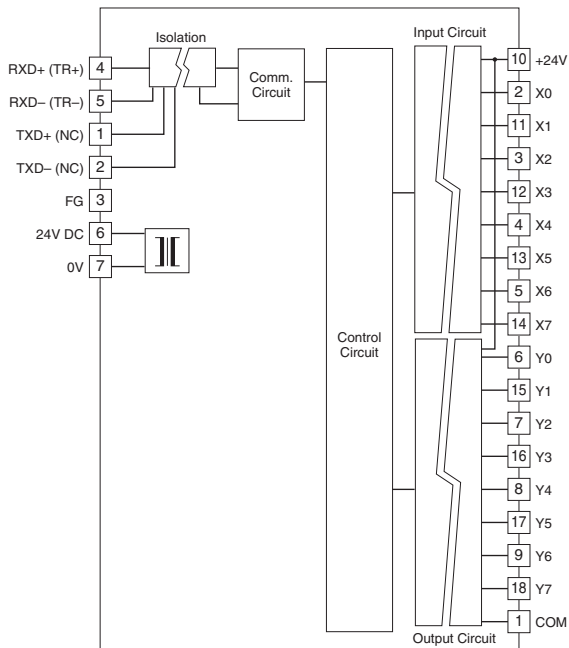

Note: Terminal numbers in parentheses are for half-duplex communication model.

CIRCUIT DIAGRAM

Note: In order to improve EMC performance, bond the FG terminal to ground.

Caution: FG terminal is NOT a protective conductor terminal.

Input Circuit

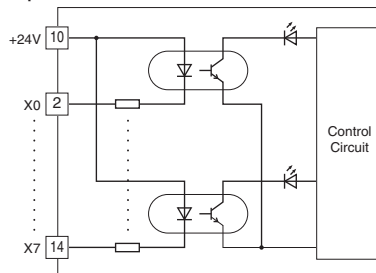

Output Circuit

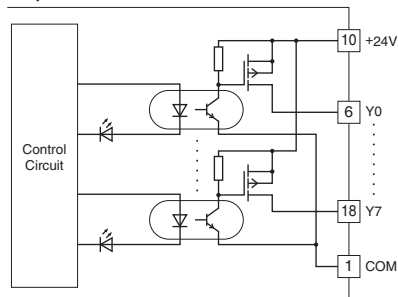

I/O Connection Example

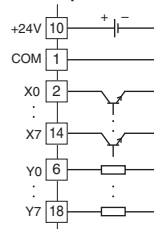

NPN DISCRETE INPUT & NPN TRANSISTOR OUTPUT MODULE, 8 points each

MODEL: R7HL-DAC16C

TERMINAL ASSIGNMENTS

10 +24V	11 X1	12 X3	13 X5	14 X7	15 Y1	16 Y3	17 Y5	18 Y7
1 COM	2 X0	3 X2	4 X4	5 X6	6 Y0	7 Y2	8 Y4	9 Y6

NO.	ID	FUNCTION	NO.	ID	FUNCTION
1	COM	Common	10	+24V	24V DC
2	X0	Input 0	11	X1	Input 1
3	X2	Input 2	12	X3	Input 3
4	X4	Input 4	13	X5	Input 5
5	X6	Input 6	14	X7	Input 7
6	Y0	Output 0	15	Y1	Output 1
7	Y2	Output 2	16	Y3	Output 3
8	Y4	Output 4	17	Y5	Output 5
9	Y6	Output 6	18	Y7	Output 7

SPECIFICATIONS

COMMON SPECIFICATIONS

Input common: Positive common (NPN) per 8 points
Output common: Negative common (NPN) per 8 points
Number of I/O: Input, 8 points; Output, 8 points
Maximum I/O applicable at once: No limit (at 24 V DC)
I/O status indicator: LED turns ON with contact ON
Isolation: Input or output to HLS to power input to FG
Data allocation: 1

INPUT

Rated input voltage: 24 V DC $\pm 10\%$; ripple 5 %p-p max.
ON voltage / current: ≥ 15 V DC (I/O's X0 through X7 to +24 V) / ≥ 3.5 mA
OFF voltage / current: ≤ 5 V DC (I/O's X0 through X7 to +24 V) / ≤ 1 mA
Input current: ≤ 5.5 mA per point at 24 V DC
Input resistance: Approx. 4.4 k Ω
ON delay: ≤ 0.5 msec.
OFF delay: ≤ 0.5 msec.

OUTPUT

Rated load voltage: 24 V DC $\pm 10\%$
Rated output current: 0.25 A per point, 2.0 A per common
Residual voltage: ≤ 1.2 V
Leakage current: ≤ 0.1 mA
ON delay: ≤ 0.2 msec.
OFF delay: ≤ 0.5 msec.
 (When driving an inductive load, connect a diode in parallel with the load.)

OPERATING MODE SETTING

(*) Factory setting

Caution ! - SW1-1 through 1-6 are unused. Be sure to turn off unused ones.

Output at the Loss of Communication (SW1-7)

SW1-7	Output at the loss of communication
OFF	Hold the output (*) (maintains the last data received normally)
ON	Reset the output (turned off)

Transfer Rate (SW1-8)

SW1-8	Transfer rate
OFF	12Mbps (*)
ON	6Mbps

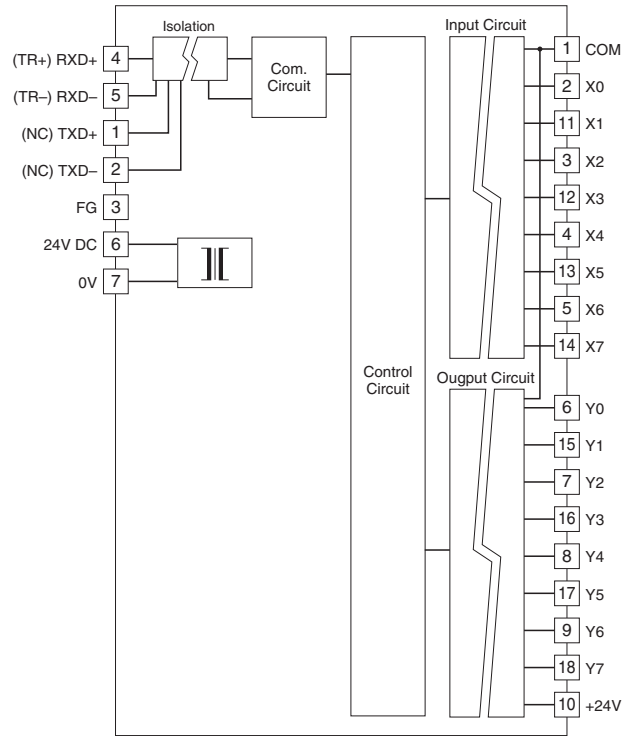

Note: Terminal numbers in parentheses are for half-duplex communication model.

CIRCUIT DIAGRAM

Note: In order to improve EMC performance, bond the FG terminal to ground.

Caution: FG terminal is NOT a protective conductor terminal.

Input Circuit

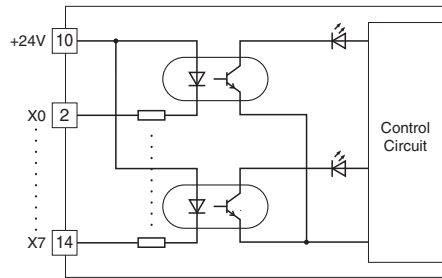

Output Circuit

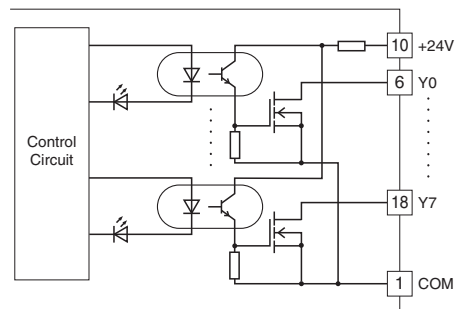

I/O Connection Example

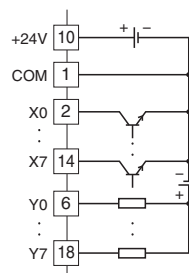

DISCRETE INPUT & NPN TRANSISTOR OUTPUT MODULE, 8 points each

(independent I/O common)

MODEL: R7HL-DAC16ES

SPECIFICATIONS

COMMON SPECIFICATIONS

Input common: Positive or negative (NPN/PNP) per 8 points

Output common: Negative common (NPN) per 8 points

Number of I/O: Input, 8 points; Output, 8 points

Maximum I/O applicable at once: No limit (at 24 V DC)

I/O status indicator: LED turns ON with contact ON

Isolation: Input to output to HLS to power input to FG

Data allocation: 1

INPUT

Rated input voltage: 24 V DC $\pm 10\%$; ripple 5 %p-p max.

ON voltage/current: ≥ 15 V DC (input-COM) / ≥ 3.5 mA

OFF voltage/current: ≤ 5 V DC (input-COM) / ≤ 1 mA

Input current: ≤ 5.5 mA per point at 24 V DC

Input resistance: Approx. 4.4 k Ω

ON delay: ≤ 0.5 msec.

OFF delay: ≤ 0.5 msec.

OUTPUT

Rated load voltage: 24 V DC $\pm 10\%$

Rated output current: 0.25 A per point, 2.0 A per common

Residual voltage: ≤ 1.2 V

Leakage current: ≤ 0.1 mA

ON delay: ≤ 0.2 msec.

OFF delay: ≤ 0.5 msec.

(When driving an inductive load, connect a diode in parallel with the load.)

OPERATING MODE SETTING

(*) Factory setting

Caution ! - SW1-1 through 1-6 are unused. Be sure to turn off unused ones.

Output at the Loss of Communication (SW1-7)

SW1-7	Output at the loss of communication
OFF	Hold the output (*) (maintains the last data received normally)
ON	Reset the output (turned off)

Transfer Rate (SW1-8)

SW1-8	Transfer rate
OFF	12Mbps (*)
ON	6Mbps

TERMINAL ASSIGNMENTS

11	12	13	14	15	16	17	18	19	20
COM	X1	X3	X5	X7	Y1	Y3	Y5	Y7	+24V
1	2	3	4	5	6	7	8	9	10
COM	X0	X2	X4	X6	Y0	Y2	Y4	Y6	0V

NO.	ID	FUNCTION	NO.	ID	FUNCTION
1	COM	Input common	11	COM	Input common
2	X0	Input 0	12	X1	Input 1
3	X2	Input 2	13	X3	Input 3
4	X4	Input 4	14	X5	Input 5
5	X6	Input 6	15	X7	Input 7
6	Y0	Output 0	16	Y1	Output 1
7	Y2	Output 2	17	Y3	Output 3
8	Y4	Output 4	18	Y5	Output 5
9	Y6	Output 6	19	Y7	Output 7
10	0V	0V (Output common)	20	+24V	24VDC

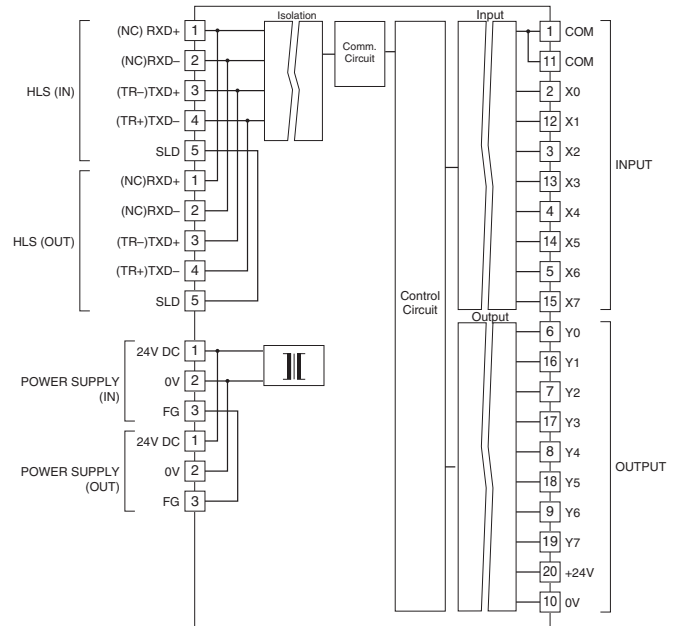

Note: Terminal numbers in parentheses are for half-duplex communication model.

■ Input Circuit

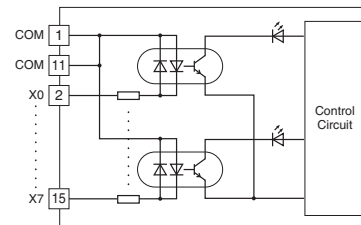

■ Output Circuit

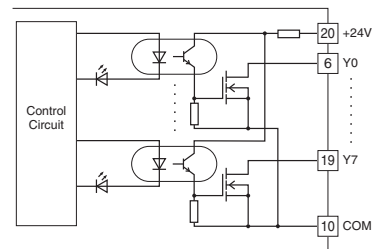

■ I/O Connection Example

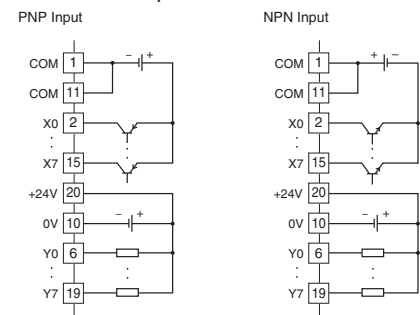

CIRCUIT DIAGRAM

Note: In order to improve EMC performance, bond the FG terminal to ground.

Caution: FG terminal is NOT a protective conductor terminal.

RELAY CONTACT OUTPUT MODULE, 8 points

MODEL: R7HL-DC8C

SPECIFICATIONS

- Common:** 1 common per 4 points (4 terminals)
- Maximum current load:** 1.0 A per point
- Common current:** Max. 4 A per common
- Number of I/O:** Relay contact output, 8 points
- Maximum outputs applicable at once:** No limit (at 24 V DC)
- Output status indicator:** LED turns ON with contact ON
- Isolation:** Output to HLS to power input to FG
- Data allocation:** 1
- Relay driving power:** 24 V DC $\pm 10\%$, ≥ 60 mA
- Rated load:** 250 V AC @ 1 A ($\cos \phi = 1$)
30 V DC @ 1 A (resistive load)
- Maximum switching voltage:** 250 V AC or 30 V DC
- Maximum switching power:** 250 VA or 30 W
- Minimum load:** 24 V DC @ 5 mA
- Mechanical life:** 2×10^7 cycles (rate 300/min.)
- When driving an inductive load, external contact protection and noise quenching are recommended.
- ON delay:** ≤ 10 msec.
- OFF delay:** ≤ 10 msec.

OPERATING MODE SETTING

(*) Factory setting

Caution ! - SW1-1 through 1-6 are unused. Be sure to turn off unused ones.

• Output at the Loss of Communication (SW1-7)

SW1-7	Output at the loss of communication
OFF	Hold the output (*) (maintains the last data received normally)
ON	Reset the output (turned off)

• Transfer Rate (SW1-8)

SW1-8	Transfer rate
OFF	12Mbps (*)
ON	6Mbps

TERMINAL ASSIGNMENTS

10	11	12	13	14	15	16	17	18
+24V	Y0	Y1	Y2	Y3	Y4	Y5	Y6	Y7
1	2	3	4	5	6	7	8	9
0V	COM0	COM0	COM0	COM0	COM1	COM1	COM1	COM1

NO.	ID	FUNCTION	NO.	ID	FUNCTION
1	0 V	0 V	10	+24 V	24 V DC
2	COM0	Common 0	11	Y0	Output 0
3	COM0	Common 0	12	Y1	Output 1
4	COM0	Common 0	13	Y2	Output 2
5	COM0	Common 0	14	Y3	Output 3
6	COM1	Common 1	15	Y4	Output 4
7	COM1	Common 1	16	Y5	Output 5
8	COM1	Common 1	17	Y6	Output 6
9	COM1	Common 1	18	Y7	Output 7

CIRCUIT DIAGRAM

Note: In order to improve EMC performance, bond the FG terminal to ground.

Caution: FG terminal is NOT a protective conductor terminal.

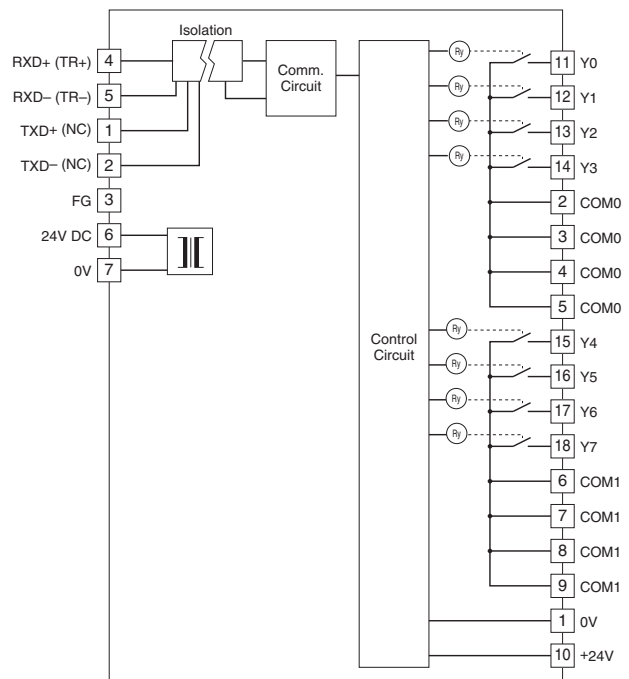

Note: Terminal numbers in parentheses are for half-duplex communication model.

■ Output Connection Example

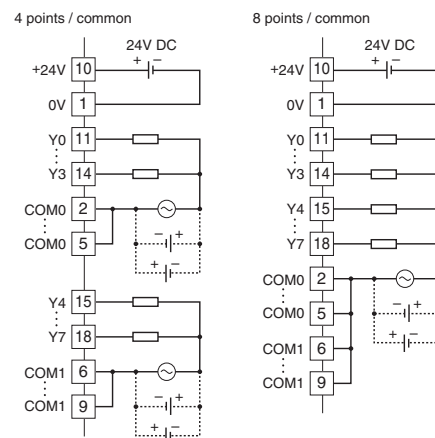

DC VOLTAGE/CURRENT INPUT MODULE, 4 points

MODEL: R7HL-SV4

SPECIFICATIONS

Isolation: Input 0 to input 1 to input 2 to input 3 to power input to HLS to FG

Data allocation: 4

Converted data range: 0 - 10000 of the input range

• **Input range**

Wide span voltage: -10 - +10 V DC, -5 - +5 V DC, 0 - 10 V DC, 0 - 5 V DC, 1 - 5 V DC

Narrow span voltage: -1 - +1 V DC, 0 - 1 V DC, -0.5 - +0.5 V DC

Current range: -20 - +20 mA DC, 0 - 20 mA DC, 4 - 20 mA DC

• **Input resistance**

Wide span voltage: $\geq 1 \text{ M}\Omega$

Narrow span voltage: $\geq 100 \text{ k}\Omega$

Current range: 70Ω

Conversion rate / conversion accuracy:

10 msec./ $\pm 0.8 \%$, 20 msec./ $\pm 0.4 \%$, 40 msec./ $\pm 0.2 \%$,

80 msec./ $\pm 0.1 \%$

Response time: Conversion rate $\times 2 + 50$ msec. (0 - 90 %)

Temperature coefficient: $\pm 0.015 \%/^{\circ}\text{C}$ ($\pm 0.008 \%/^{\circ}\text{F}$)

OPERATING MODE SETTING

(*) Factory setting

Caution ! - SW1-1, SW1-2 and SW1-7 are unused. Be sure to turn off unused ones.

• **Input Range (SW1-3, 1-4, 1-5, 1-6)**

SW1-3	SW1-4	SW1-5	SW1-6	Input range
OFF	OFF	OFF	OFF	-10 - +10V DC (*)
ON	OFF	OFF	OFF	-5 - +5V DC
OFF	ON	OFF	OFF	-1 - +1V DC
ON	ON	OFF	OFF	0 - 10V DC
OFF	OFF	ON	OFF	0 - 5V DC
ON	OFF	ON	OFF	1 - 5V DC
OFF	ON	ON	OFF	0 - 1V DC
ON	ON	ON	OFF	-0.5 - +0.5V DC
ON	OFF	OFF	ON	-20 - +20mA DC
OFF	ON	OFF	ON	4 - 20mA DC
ON	ON	OFF	ON	0 - 20mA DC
ON	ON	ON	ON	PC Configurator setting

• **Transfer Rate (SW1-8)**

SW1-8	Transfer rate
OFF	12Mbps (*)
ON	6Mbps

TERMINAL ASSIGNMENTS

10	11	12	13	14	15	16	17	18
VL0	I0	VL1	I1	NC	VL2	I2	VL3	I3
1	2	3	4	5	6	7	8	9
VH0	COM0	VH1	COM1	NC	VH2	COM2	VH3	COM3

NO.	ID	FUNCTION	NO.	ID	FUNCTION
1	VH0	Wide span volt. 0	10	VL0	Narrow span volt. 0
2	COM0	Common 0	11	I0	Current range 0
3	VH1	Wide span volt. 1	12	VL1	Narrow span volt. 1
4	COM1	Common 1	13	I1	Current range 1
5	NC	No connection	14	NC	No connection
6	VH2	Wide span volt. 2	15	VL2	Narrow span volt. 2
7	COM2	Common 2	16	I2	Current range 2
8	VH3	Wide span volt. 3	17	VL3	Narrow span volt. 3
9	COM3	Common 3	18	I3	Current range 3

CIRCUIT DIAGRAM

Note: In order to improve EMC performance, bond the FG terminal to ground.

Caution: FG terminal is NOT a protective conductor terminal.

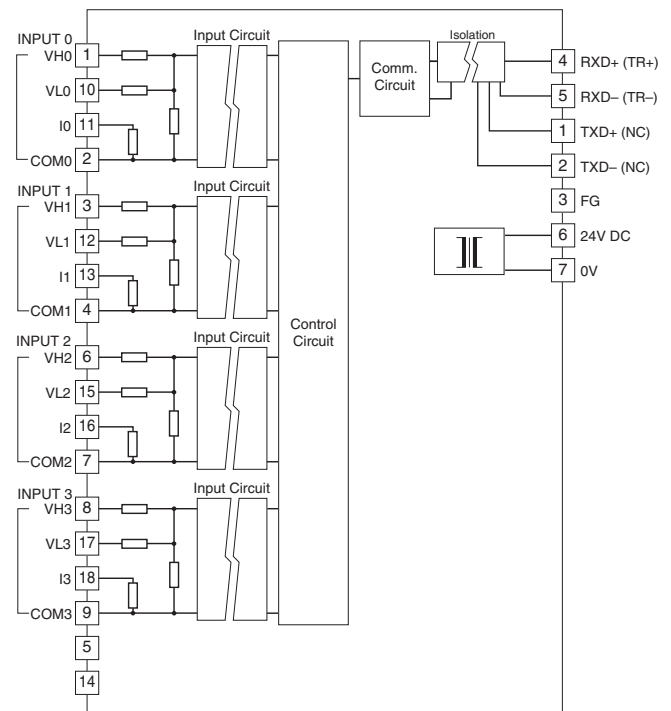

Note: Terminal numbers in parentheses are for half-duplex communication model.

■ **Input Connection Examples**

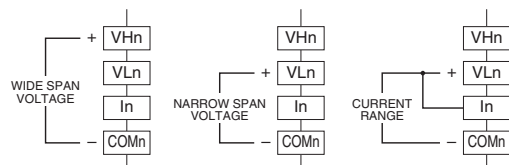

Be sure to close across VLn and In terminals for a current input.

DC VOLTAGE/CURRENT INPUT MODULE, 4 points

(high speed, non-isolated)

MODEL: R7HL-SVF4

SPECIFICATIONS

Isolation: Input to HLS to power input to FG

Data allocation: 4

Converted data range: 0 - 10000 of the input range

• **Input range**

Wide span voltage: -10 - +10 V DC, -5 - +5 V DC,

0 - 10 V DC, 0 - 5 V DC, 1 - 5 V DC

Narrow span voltage: -1 - +1 V DC, 0 - 1 V DC,

-0.5 - +0.5 V DC

Current range: -20 - +20 mA DC, 0 - 20 mA DC,

4 - 20 mA DC

• **Input resistance**

Wide span voltage: > 1 MΩ

Narrow span voltage: > 100 kΩ

Current range: 50 Ω

Conversion rate/conversion accuracy: 2 msec./±0.1 %

Response time: Conversion rate × 2 + scan time (0 - 90 %)

Scan time depends on the Final Satellite (FS) value of

Center IC (master) configuration and transfer rate (T_{BPS}).

It is calculated with the following formula.

Scan time = 182 × FS × T_{BPS} (sec.)

E.g) When "Final satellite value" = 63, transfer rate = 12

Mbps, scan time is = 182 × 63 × 1/12 M = 0.9555 msec.

Temperature coefficient: ±0.015 %/°C (±0.008 %/°F)

OPERATING MODE SETTING

(*) Factory setting

Caution ! - SW1-1, SW1-2 and SW1-7 are unused. Be sure to turn off unused ones.

• **Input Range (SW1-3, 1-4, 1-5, 1-6)**

SW1-3	SW1-4	SW1-5	SW1-6	Input range
OFF	OFF	OFF	OFF	-10 - +10V DC (*)
ON	OFF	OFF	OFF	-5 - +5V DC
OFF	ON	OFF	OFF	-1 - +1V DC
ON	ON	OFF	OFF	0 - 10V DC
OFF	OFF	ON	OFF	0 - 5V DC
ON	OFF	ON	OFF	1 - 5V DC
OFF	ON	ON	OFF	0 - 1V DC
ON	ON	ON	OFF	-0.5 - +0.5V DC
ON	OFF	OFF	ON	-20 - +20mA DC
OFF	ON	OFF	ON	4 - 20mA DC
ON	ON	OFF	ON	0 - 20mA DC
ON	ON	ON	ON	PC Configurator setting

• **Transfer Rate (SW1-8)**

SW1-8	Transfer rate
OFF	12Mbps (*)
ON	6Mbps

TERMINAL ASSIGNMENTS

10	11	12	13	14	15	16	17	18
VL0	I0	VL1	I1	NC	VL2	I2	VL3	I3
1	2	3	4	5	6	7	8	9
VH0	COM0	VH1	COM1	NC	VH2	COM2	VH3	COM3

NO.	ID	FUNCTION	NO.	ID	FUNCTION
1	VH0	Wide span volt. 0	10	VL0	Narrow span volt. 0
2	COM0	Common 0	11	I0	Current range 0
3	VH1	Wide span volt. 1	12	VL1	Narrow span volt. 1
4	COM1	Common 1	13	I1	Current range 1
5	NC	No connection	14	NC	No connection
6	VH2	Wide span volt. 2	15	VL2	Narrow span volt. 2
7	COM2	Common 2	16	I2	Current range 2
8	VH3	Wide span volt. 3	17	VL3	Narrow span volt. 3
9	COM3	Common 3	18	I3	Current range 3

CIRCUIT DIAGRAM

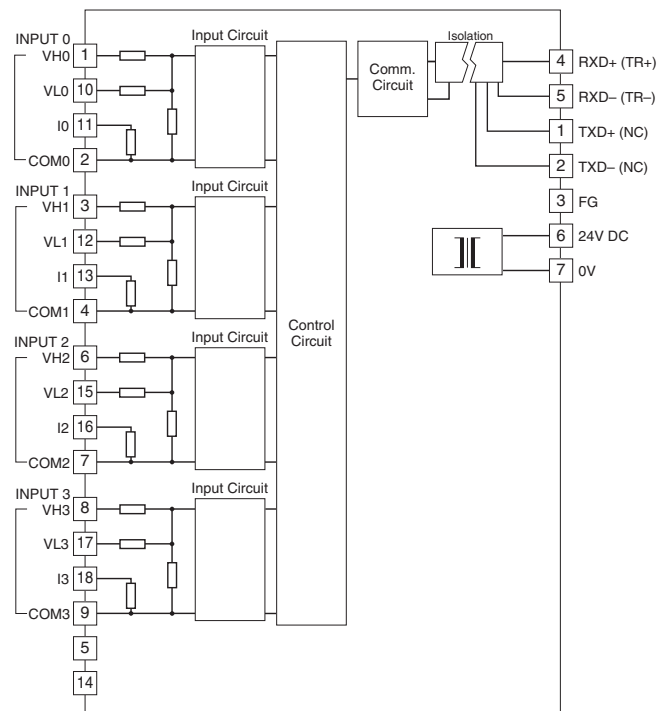

Note: Terminal numbers in parentheses are for half-duplex communication model.

■ **Input Connection Examples**

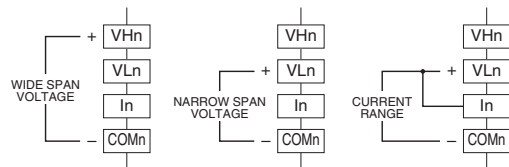

Be sure to close across VLn and In terminals for a current input.

THERMOCOUPLE INPUT MODULE, 4 points

MODEL: R7HL-TS4

SPECIFICATIONS

Isolation: Input 0 to input 1 to input 2 to input 3 to power input to HLS to FG

Data allocation: 4

Converted data range: Engineering unit value (°C, K) × 10 (integer); No multiplication for °F

Linearization: Standard

Thermocouple: K, E, J, T, B, R, S, C, N, U, L, P, PR

Cold junction compensation: CJC sensor attached to the input terminals

Input resistance: ≥ 30 kΩ

Burnout sensing: ≤ 0.1 μA

Conversion accuracy: ±1°C (±1.8°F);

±2.0°C (±3.6°F) for B, R, S, C, PR

Conversion rate: 250 msec. or 500 msec.

Response time: Conversion rate × 2 + 50 msec. (0 - 90 %)

Temperature coefficient: ±0.015 %/°C (±0.008 %/°F) of max. span

CJC error: ±1.0°C at 25°C ±10°C

(±1.8°F at 77°F ±18°F)

±1.5°C (±2.7°F) for R, S, PR

T/C	BURNOUT INDICATION (°C)		CONFORMANCE RANGE (°C)
	Downscale	Upscale	
K (CA)	-272	+1472	-150 to +1370
E (CRC)	-272	+1120	-170 to +1000
J (IC)	-260	+1300	-180 to +1200
T (CC)	-272	+ 500	-170 to + 400
B (RH)	24	1920	1000 to 1760
R	-100	+1860	380 to 1760
S	-100	+1860	400 to 1760
C (WRe 5-26)	-52	+2416	100 to 2315
N	-272	+1400	-130 to +1300
U	-252	+ 700	-200 to +600
L	-252	+1000	-200 to +900
P (Platinel II)	-52	+1496	0 to 1395
(PR)	-52	+1860	300 to 1760

T/C	BURNOUT INDICATION (°F)		CONFORMANCE RANGE (°F)
	Downscale	Upscale	
K (CA)	-458	+2682	-238 to +2498
E (CRC)	-458	+2048	-274 to +1832
J (IC)	-436	+2372	-292 to +2192
T (CC)	-458	+932	-274 to +752
B (RH)	75	3488	1832 to 3200
R	-148	+3380	716 to 3200
S	-148	+3380	752 to 3200
C (WRe 5-26)	-62	+4381	212 to 4199
N	-458	+2552	-202 to +2372
U	-422	+1292	-328 to +1112
L	-422	+1832	-328 to +1652
P (Platinel II)	-62	+2725	32 to 2543
(PR)	-62	+3380	572 to 3200

OPERATING MODE SETTING

(*) Factory setting

Caution ! - SW1-1 and SW1-7 are unused. Be sure to turn off unused ones.

• Thermocouple Type (SW1-3, 1-4, 1-5, 1-6)

SW1-3	SW1-4	SW1-5	SW1-6	Thermocouple type
OFF	OFF	OFF	OFF	K (CA) (*)
ON	OFF	OFF	OFF	E (CRC)
OFF	ON	OFF	OFF	J (IC)
ON	ON	OFF	OFF	T (CC)
OFF	OFF	ON	OFF	B (RH)
ON	OFF	ON	OFF	R
OFF	ON	ON	OFF	S
ON	ON	ON	OFF	C (WRe 5-26)
OFF	OFF	OFF	ON	N
ON	OFF	OFF	ON	U
OFF	ON	OFF	ON	L
ON	ON	OFF	ON	P (Platine II)
OFF	OFF	ON	ON	(PR)
ON	ON	ON	ON	PC Configurator setting

• Burnout (SW1-2)

SW1-2	Burnout
OFF	Upscale (*)
ON	Downscale

• Transfer Rate (SW1-8)

SW1-8	Transfer rate
OFF	12Mbps (*)
ON	6Mbps

TERMINAL ASSIGNMENTS

10	11	12	13	14	15	16	17	18
+IN0	-IN0	+IN1	-IN1	NC	+IN2	-IN2	+IN3	-IN3
+CJ0	-CJ0	+CJ1	-CJ1	NC	+CJ2	-CJ2	+CJ3	-CJ3

NO.	ID	FUNCTION	NO.	ID	FUNCTION
1	+CJ0	CJC + 0	10	+IN0	T/C + 0
2	-CJ0	CJC - 0	11	-IN0	T/C - 0
3	+CJ1	CJC + 1	12	+IN1	T/C + 1
4	-CJ1	CJC - 1	13	-IN1	T/C - 1
5	NC	No connection	14	NC	No connection
6	+CJ2	CJC + 2	15	+IN2	T/C + 2
7	-CJ2	CJC - 2	16	-IN2	T/C - 2
8	+CJ3	CJC + 3	17	+IN3	T/C + 3
9	-CJ3	CJC - 3	18	-IN3	T/C - 3

CIRCUIT DIAGRAM

Note: In order to improve EMC performance, bond the FG terminal to ground.

Caution: FG terminal is NOT a protective conductor terminal.

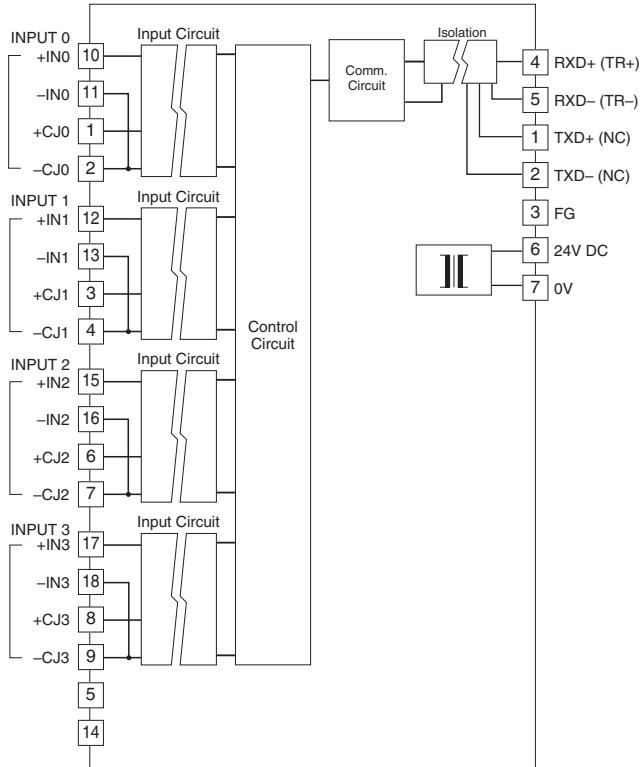

Note: Terminal numbers in parentheses are for half-duplex communication model.

Input Connection Example

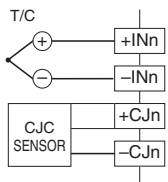

RTD INPUT MODULE, 4 points

MODEL: R7HL-RS4

SPECIFICATIONS

Isolation: Input 0 to input 1 to input 2 to input 3 to power input to HLS to FG

Data allocation: 4

Converted data range: Engineering unit value (°C, K) × 10 (integer); No multiplication for °F

Linearization: Standard

RTD: Pt 100 (JIS '97, IEC), Pt 100 (JIS '89), JPt 100 (JIS '89), Pt 50 Ω (JIS '81), Ni 100, Cu 10, Cu 50

Sensing current: ≤ 1 mA

Input resistance: ≥ 1 MΩ

Maximum leadwire resistance: 100 Ω per wire

Conversion accuracy: ±1°C (±1.8°F); ±3°C (±5.4°F) for Cu 10

Conversion rate: 250 msec. or 500 msec.

Response time: Conversion rate × 2 + 50 msec. (0 - 90 %)

Temperature coefficient: ±0.015 %/°C (±0.008 %/°F) of max. span

RTD	BURNOUT INDICATION (°C)		CONFORMANCE RANGE (°C)
	Downscale	Upscale	
Pt 100 (JIS '97, IEC)	-240	+900	-200 to +850
Pt 100 (JIS '89)	-240	+900	-200 to +660
JPt 100 (JIS '89)	-236	+560	-200 to +510
Pt 50 Ω (JIS '81)	-236	+700	-200 to +649
Ni 100	-100	+252	-80 to +250
Cu 10 @ 25°C	-212	+312	-50 to +250
Cu 50	-100	+200	-50 to +150

RTD	BURNOUT INDICATION (°F)		CONFORMANCE RANGE (°F)
	Downscale	Upscale	
Pt 100 (JIS '97, IEC)	-400	+1652	-328 to +1562
Pt 100 (JIS '89)	-400	+1652	-328 to +1220
JPt 100 (JIS '89)	-393	+1040	-328 to +950
Pt 50 Ω (JIS '81)	-393	+1292	-328 to +1200
Ni 100	-148	+486	-112 to +482
Cu 10 @ 25°C	-350	+594	-58 to +482
Cu 50	-148	+392	-58 to +302

OPERATING MODE SETTING

(*) Factory setting

Caution ! - SW1-1 and SW1-7 are unused. Be sure to turn off unused ones.

• RTD Type (SW1-3, 1-4, 1-5, 1-6)

SW1-3	SW1-4	SW1-5	SW1-6	RTD Type
OFF	OFF	OFF	OFF	Pt 100 (JIS '97, IEC) (*)
ON	OFF	OFF	OFF	Pt 100 (JIS '89)
OFF	ON	OFF	OFF	JPt 100 (JIS '89)
ON	ON	OFF	OFF	Pt 50Ω (JIS '81)
OFF	OFF	ON	OFF	Ni 100
ON	OFF	ON	OFF	Cu 10 @ 25°C
OFF	OFF	OFF	ON	Cu 50
ON	ON	ON	ON	PC Configurator setting

• Burnout (SW1-2)

SW1-2	Burnout
OFF	Upscale (*)
ON	Downscale

• Transfer Rate (SW1-8)

SW1-8	Transfer rate
OFF	12Mbps (*)
ON	6Mbps

TERMINAL ASSIGNMENTS

10 INA0	11 INb0	12 INA1	13 INb1	14 NC	15 INA2	16 INb2	17 INA3	18 INb3
1 NC	2 INB0	3 NC	4 INB1	5 NC	6 NC	7 INB2	8 NC	9 INB3

NO.	ID	FUNCTION	NO.	ID	FUNCTION
1	NC	No connection	10	INA0	RTD 0-A
2	INB0	RTD 0-B	11	INb0	RTD 0-b
3	NC	No connection	12	INA1	RTD 1-A
4	INB1	RTD 1-B	13	INb1	RTD 1-b
5	NC	No connection	14	NC	No connection
6	NC	No connection	15	INA2	RTD 2-A
7	INB2	RTD 2-B	16	INb2	RTD 2-b
8	NC	No connection	17	INA3	RTD 3-A
9	INB3	RTD 3-B	18	INb3	RTD 3-b

CIRCUIT DIAGRAM

Note: In order to improve EMC performance, bond the FG terminal to ground.

Caution: FG terminal is NOT a protective conductor terminal.

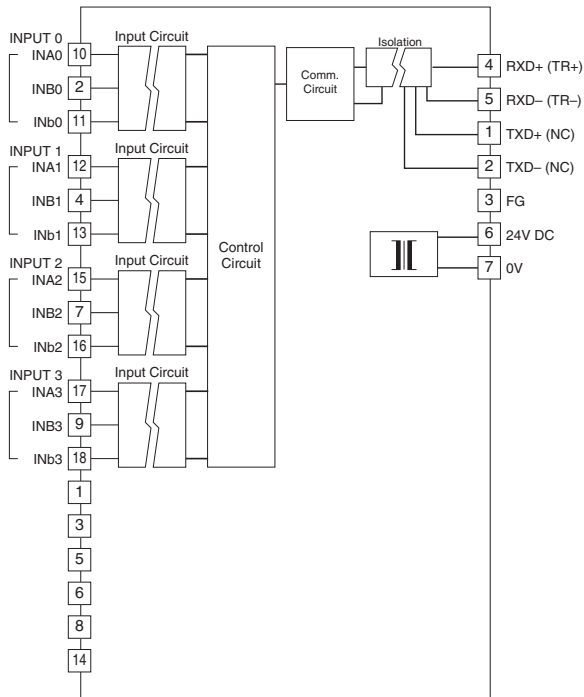

Note: Terminal numbers in parentheses are for half-duplex communication model.

■ Input Connection Example

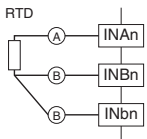

STRAIN GAUGE INPUT MODULE

(with monitor output, 2 points)

MODEL: R7HL-LC2**SPECIFICATIONS****Isolation:** Input 0 or output 0 to Input 1 or output 1 to HLS to power input to FG**Data allocation:** 2**INPUT****Excitation:** 5 V $\pm 10\%$ or 2.5 V $\pm 10\%$

(Input range doubled in the case of 2.5 V excitation)

Changeable with switch

Maximum current: max. 60 mA (Up to 4 strain gauges of 350 Ω can be connected in parallel-adding connection at 5 V excitation)

max. 100 mA (at 2.5 V excitation)

Input range:

Option code /R20

-2 - +2 mV/V (at 5 V excitation)

-4 - +4 mV/V (at 2.5 V excitation)

Option code /R10

-1 - +1 mV/V (at 5 V excitation)

-2 - +2 mV/V (at 2.5 V excitation)

Option code /R05

-0.5 - +0.5 mV/V (at 5 V excitation)

-1 - +1 mV/V (at 2.5 V excitation)

Max. Input range:

Option code /R20

-3 - +3 mV/V (at 5 V excitation)

-6 - +6 mV/V (at 2.5 V excitation)

Option code /R10

-1.5 - +1.5 mV/V (at 5 V excitation)

- 3 - +3 mV/V (at 2.5 V excitation)

Option code /R05

-0.75 - +0.75 mV/V (at 5 V excitation)

-1.5 - +1.5 mV/V (at 2.5 V excitation)

Zero adjustment:

Option code /R20

-1 - +1 mV/V (at 5 V excitation)

-2 - +2 mV/V (at 2.5 V excitation)

Option code /R10

-0.5 - +0.5 mV/V (at 5 V excitation)

-1 - +1 mV/V (at 2.5 V excitation)

Option code /R05

-0.25 - +0.25 mV/V (at 5 V excitation)

-0.5 - +0.5 mV/V (at 2.5 V excitation)

Accuracy:

Option code except /R05

 $\pm 0.04\%$ (Averaging 128 samples or more) $\pm 0.05\%$ (Averaging 64 samples) $\pm 0.10\%$ (Averaging 8, 16, 32 samples) $\pm 0.15\%$ (Averaging 4 samples) $\pm 0.20\%$ (Averaging 2 samples)

Option code /R05

 $\pm 0.05\%$ (Averaging 512 samples or more) $\pm 0.10\%$ (Averaging 64, 128, 256 samples) $\pm 0.20\%$ (Averaging 16, 32 samples) $\pm 0.30\%$ (Averaging 2, 4, 8 samples)**Lowpass filter:**

Approx. 2 kHz or approx. 2 Hz (option code /F2K)

Approx. 1 Hz or approx. 2 Hz (option code /F1)

Input delay time:

Lowpass filter 2 kHz max. 20 msec. (0 - 90%)

Lowpass filter 2 Hz max. 200 msec. (0 - 90%)

Lowpass filter 1 Hz max. 400 msec. (0 - 90%)

Conversion rate: min. 2000 samples/sec.**Resolution:** 1/10000**Converted data range:**

Input 0 / input 1: 0 - 10000 of the range from zero to span

Total input data: Sum of input 0 and input 1

Load coefficient: 10.00 - 100.00 (%)**Averaging:** 2, 4, 8, 16, 32, 64, 128, 256, 512, 1024 samples**Temperature coefficient:** $\pm 0.015\%/^{\circ}\text{C}$ ($\pm 0.008\%/^{\circ}\text{F}$)**Input status indicator LED:** 0 - F

(Refer to the instruction manual)

OUTPUT**Output range:** -10 - +10 V DC (of -10000 - +10000 (% $\times 100$))**Operational range:** -115 - +115 %**Load resistance:** $\geq 100\text{ k}\Omega$ **Conversion accuracy:** $\pm 0.1\%$ **Response time:** 250 msec. (0 - 90 %)**Temperature coefficient:** $\pm 0.015\%/^{\circ}\text{C}$ ($\pm 0.008\%/^{\circ}\text{F}$)

OPERATING MODE SETTING

(*) Factory setting

Caution ! - SW1-1 is unused. Be sure to turn off unused one.

• **Excitation (SW1-2)**

SW1-2	Excitation
OFF	5 V (*)
ON	2.5 V

• **Lowpass Filter (SW1-3)**

SW1-3	Lowpass filter
OFF	2 kHz (/F2K) / 1 Hz (/F1) (*)
ON	2 Hz

• **Averaging (SW1-4, 1-5, 1-6, 1-7)**

SW1-4	SW1-5	SW1-6	SW1-7	Averaging
OFF	OFF	OFF	OFF	2 samples (*)
ON	OFF	OFF	OFF	4 samples
OFF	ON	OFF	OFF	8 samples
ON	ON	OFF	OFF	16 samples
OFF	OFF	ON	OFF	32 samples
ON	OFF	ON	OFF	64 samples
OFF	ON	ON	OFF	128 samples
ON	ON	ON	OFF	256 samples
OFF	OFF	OFF	ON	512 samples
ON	OFF	OFF	ON	1024 samples

• **Transfer Rate (SW1-8)**

SW1-8	Transfer rate
OFF	12Mbps (*)
ON	6Mbps

TERMINAL ASSIGNMENTS

10	11	12	13	14	15	16	17	18
NC	+EXC0	+IN0	NC	V0	+EXC1	+IN1	NC	V1
1	2	3	4	5	6	7	8	9
NC	-EXC0	-IN0	SLD0	C0	-EXC1	-IN1	SLD1	C1

NO.	ID	FUNCTION	NO.	ID	FUNCTION
1	NC	No connection	10	NC	No connection
2	-EXC0	Excitation 0-	11	+EXC0	Excitation 0+
3	-IN0	Input 0-	12	+IN0	Input 0+
4	SLD0	Shield 0	13	NC	No connection
5	C0	Voltage output 0-	14	V0	Voltage output 0+
6	-EXC1	Excitation 1-	15	+EXC1	Excitation 1+
7	-IN1	Input 1-	16	+IN1	Input 1+
8	SLD1	Shield 1	17	NC	No connection
9	C1	Voltage output 1-	18	V1	Voltage output 1+

SCHEMATIC CIRCUITRY

Note: In order to improve EMC performance, bond the FG terminal to ground.

Caution: FG terminal is NOT a protective conductor terminal.

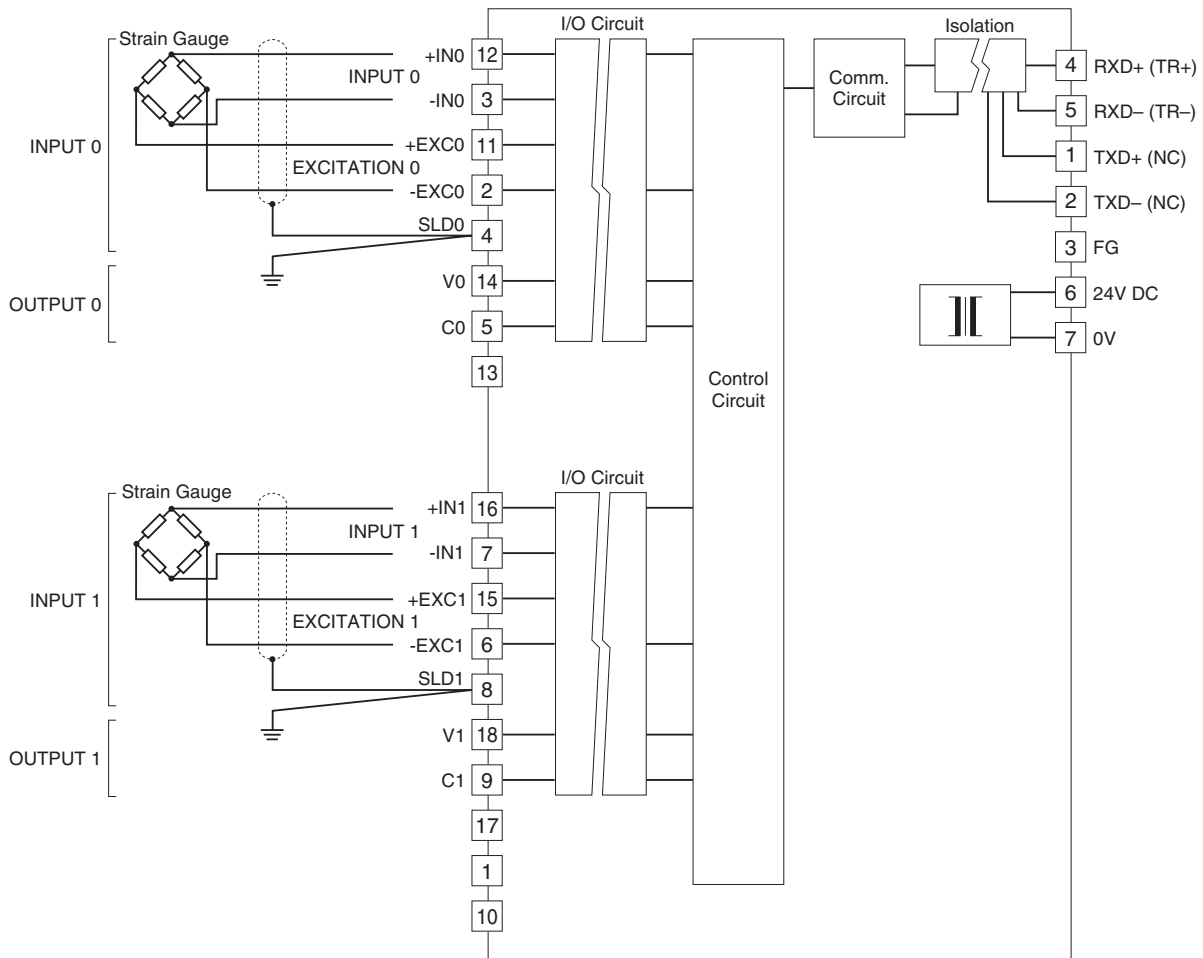

Note: Terminal numbers in parentheses are for half-duplex communication model.

TOTALIZED PULSE INPUT MODULE

(4 points, non-isolated)

MODEL: R7HL-PA4E

SPECIFICATIONS

Common: Positive common (NPN) per 4 points

I/O status indicator: Red LED turns on with contact on (Lo between GND and IN0 through IN3)

Isolation: Input or sensor excitation to HLS to power input

Data allocation: 4

Rated input voltage: 24 V DC $\pm 10\%$; ripple 5 %p-p max.

ON voltage / current: ≥ 16 V (input – “+24 V”) / ≥ 7.2 mA

OFF voltage / current: ≤ 6 V (input – “+24 V”) / ≤ 2.5 mA

Input current: 11.2 mA per point at 24 V DC

Input resistance: Approx. 2 k Ω

Max. Frequency: 10 kHz

Min. pulse width requirement: 20 μ sec. for both ON and OFF

• Counter

Number of channels: 4

Count range: 0000H to FFFFH (16 bits)

Operating mode: Ring up counter

Max. ring value: FFFFH

Pulse detection: Sink (the output of sensor turns on)

Count reset: LSB of Do area (set per channel)

0: Count up

1: Reset

• Sensor Excitation (External)

Supply voltage: 24 V DC $\pm 10\%$ (ripple 5 %p-p max.)

Supply current: 0.4 A per point, 1.6 A per common

OPERATING MODE SETTING

(*) Factory setting

Caution ! - SW1-1 through 1-7 are unused. Be sure to turn off unused ones.

• Transfer Rate (SW1-8)

SW1-8	Transfer rate
OFF	12Mbps (*)
ON	6Mbps

TERMINAL ASSIGNMENTS

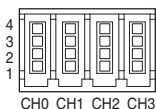

No.	ID	FUNCTION
4	IN0 through IN3	Input 0 through 3
3	GND	GND
2	NC	No connection
1	+24V	Sensor excitation

CIRCUIT DIAGRAM

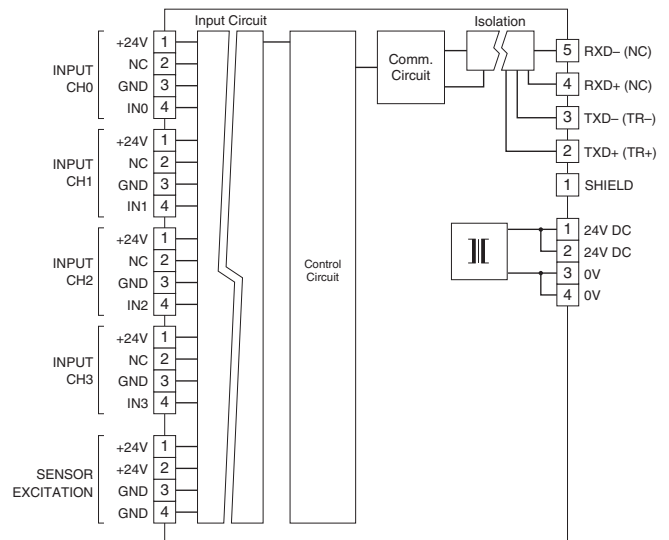

Note: Terminal numbers in parentheses are for half-duplex communication model.

Input Circuit

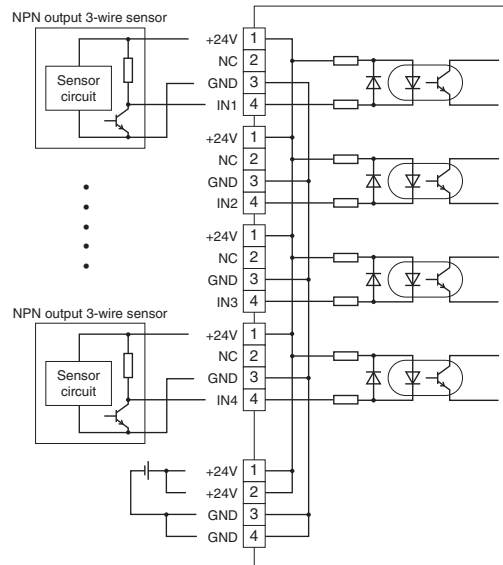

2-Wire Sensor

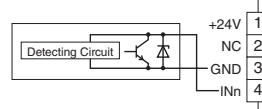

ENCODER INPUT MODULE

(2 points, non-isolated)

MODEL:**R7HL-PA2SJ****R7HL-PA2SA1****R7HL-PA2SA4****R7HL-PA2SA7****SPECIFICATIONS****Isolation**

External sensor excitation type: Input or output or sensor excitation input or encoder excitation input (for R7HL-PA2SAx) to HLS to power input to FG

Sensor excitation available type: Input or output or encoder excitation input (for R7HL-PA2SAx) or power input to HLS to FG

Counter: Linear counter

Speed conversion accuracy: $\pm 0.1\%$

Converted data range

Speed: 0 - 10000 of the input range

Position: -2 100 000 000 to +2 100 000 000

Sensor Excitation* (External):

24 V DC $\pm 10\%$, ripple 5 %p-p max., 20 mA to 1 A

* Must be supplied since the input circuit also works with it.

Not required when option /C is selected.

When Latch or Reset turns on, its current is added.

Encoder excitation (External source; only for PA2SAx)

PA2SA1: 5 V DC $\pm 5\%$, 1 A max.

PA2SA4: 12 V DC $\pm 5\%$, 1 A max.

PA2SA7: 24 V DC $\pm 5\%$, 1 A max.

Data allocation

Speed data: 4

Position data: 2

Low-end cutout (speed): Programmable within 0.1 - 50 %

Encoder pulse input

Input: 2 points

Input pulse

•PA2SJ (RS-422)

Receiver: Conforms to RS-422

•PA2SA1 (5 V open collector)

Sensing: Approx. 4 V DC @ 4.4 mA

ON/OFF level: $\geq 3\text{ k}\Omega / 3.3\text{ V}$ for OFF, $\leq 300\ \Omega / 1\text{ V}$ for ON

•PA2SA4 (12 V open collector)

Sensing: Approx. 10 V DC @ 5.7 mA

ON/OFF level: $\geq 3\text{ k}\Omega / 6.5\text{ V}$ for OFF, $\leq 400\ \Omega / 1.8\text{ V}$ for ON

•PA2SA7 (24 V open collector)

Sensing: Approx. 22 V DC @ 7.8 mA

ON/OFF level: $\geq 3\text{ k}\Omega / 11.5\text{ V}$ for OFF, $\leq 300\ \Omega / 2\text{ V}$ for ON

Pulse phase: A, B and Z

A and B phases are necessary to work.

Maximum input frequency

•PA2SJ (RS-422)

Position data: 4 MHz (quad multiplication)

Speed data: 100 kHz

•PA2SAx (Open collector)

Position data: 400 kHz (quad multiplication)

Speed data: 100 kHz

Minimum pulse width (ON and OFF)

•Phase A/B

•PA2SJ (RS-422)

Position data: $\geq 0.5\ \mu\text{sec}$.

Speed data: $\geq 5\ \mu\text{sec}$.

•PA2SAx (Open collector)

Position data: $\geq 5\ \mu\text{sec}$.

Speed data: $\geq 5\ \mu\text{sec}$.

•Phase Z $\geq 1\text{ msec}$

■ **Reset input:** discrete input

Number of input: 1 for each channel (2 points)

Common: Positive common

Detecting voltage: Supplied sensor excitation voltage

Detecting current: 5.5 mA per channel (@24 V DC)

Detecting levels:

$\geq 15\text{ V DC}$ (between +24V and RST), $\geq 3.5\text{ mA}$ for ON

$\leq 5\text{ V DC}$ (between +24V and RST), $\leq 1\text{ mA}$ for OFF

Input resistance: Approx. 4.4 k Ω

ON delay time: $\leq 50\ \mu\text{sec}$.

OFF delay time: $\leq 500\ \mu\text{sec}$.

Pulse width: $\geq 50\text{ msec}$.

■ **Latch input:** discrete input

Number of input: 1 for each channel (2 points)

Common: Positive common

Detecting voltage: Supplied sensor excitation voltage

Detecting current: 5.5 mA per channel (@24 V DC)

Detecting levels:

$\geq 15\text{ V DC}$ (between +24V and LCH), $\geq 3.5\text{ mA}$ for ON

$\leq 5\text{ V DC}$ (between +24V and LCH), $\leq 1\text{ mA}$ for OFF

Input resistance: Approx. 4.4 k Ω

ON delay time: $\leq 10\ \mu\text{sec}$.

OFF delay time: $\leq 10\ \mu\text{sec}$.

■ **Alarm Output:** Open collector

Number of output: 2 for each channel (4 points)

Common: Negative common

Rated load voltage: 24 V DC $\pm 10\%$

Max. load current: 0.1 A per point

Voltage drop at ON: $\leq 1.2\text{ V}$

Leakage current at OFF: $\leq 1\text{ mA}$

ON delay: $\leq 50\ \mu\text{sec}$.

OFF delay: $\leq 500\ \mu\text{sec}$.

Command

Data type, Preset, Reset, Latch, Reset data clear, Latch data clear and Alarm output

(For details refer to the instruction manual.)

OPERATING MODE SETTING

(¹) Factory setting

Caution ! - SW1-7 is unused. Be sure to turn it off.

• Conversion Data (SW1-1)

SW1-1	Conversion data
OFF	Position data ([*])
ON	Speed data

• Input Range (speed) (SW1-2, 1-3, 1-4)

SW1-2	SW1-3	SW1-4	Input range
OFF	OFF	OFF	0 – 100kHz ([*])
ON	OFF	OFF	0 – 10kHz
OFF	ON	OFF	0 – 1kHz
ON	ON	OFF	0 – 100Hz
OFF	OFF	ON	0 – 10Hz
ON	OFF	ON	0 – 1Hz
OFF	ON	ON	0 – 0.1Hz

• Position Count Mode

SW1-5	SW1-6	Count mode
OFF	OFF	Quad multiplication (Mode 3) ([*])
ON	OFF	Double multiplication (Mode 2)
OFF	ON	Non-multiplication (Mode 1)
ON	ON	Non-multiplication (Mode 0)

• Transfer Rate (SW1-8)

SW1-8	Transfer rate
OFF	12Mbps ([*])
ON	6Mbps

TERMINAL ASSIGNMENTS

■ R7HL-PA2SJ

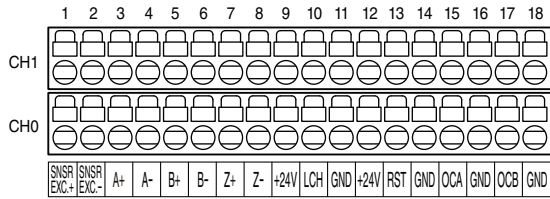

No.	ID	FUNCTION	No.	ID	FUNCTION
CH0	1	SNSR EXC.+	1	SNSR EXC.+	Sensor excitation input +
	2	SNSR EXC.-	2	SNSR EXC.-	Sensor excitation input -
	3	A+	3	A+	CH0 Phase A+
	4	A-	4	A-	CH0 Phase A-
	5	B+	5	B+	CH0 Phase B+
	6	B-	6	B-	CH0 Phase B-
	7	Z+	7	Z+	CH0 Phase Z+
	8	Z-	8	Z-	CH0 Phase Z-
	9	+24V	9	+24V	24V DC
	10	LCH	10	LCH	CH0 Latch input
	11	GND	11	GND	0V
	12	+24V	12	+24V	24V DC
	13	RST	13	RST	CH0 Reset input
	14	GND	14	GND	0V
	15	OCA	15	OCA	CH0 Open collector output A
	16	GND	16	GND	0V
	17	OCB	17	OCB	CH0 Open collector output B
	18	GND	18	GND	0V

■ R7HL-PA2SAx

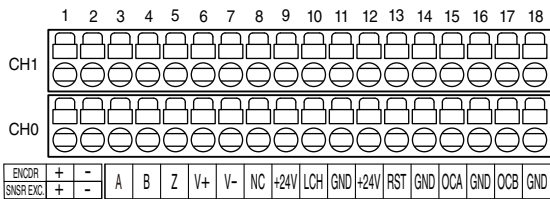

No.	ID	FUNCTION	No.	ID	FUNCTION		
CH0	1	SNSR EXC.+	Sensor excitation input +	CH1	1	SNSR EXC.+	Encoder excitation input +
	2	SNSR EXC.-	Sensor excitation input -		2	SNSR EXC.-	Encoder excitation input -
	3	A	CH0 Phase A		3	A	CH1 Phase A
	4	B	CH0 Phase B		4	B	CH1 Phase B
	5	Z	CH0 Phase Z		5	Z	CH1 Phase Z
	6	V+	Encoder excitation output +		6	V+	Encoder excitation output +
	7	V-	Encoder excitation output -		7	V-	Encoder excitation output -
	8	NC	Not used		8	NC	Not used
	9	+24V	24V DC		9	+24V	24V DC
	10	LCH	CH0 Latch input		10	LCH	CH1 Latch input
	11	GND	0V		11	GND	0V
	12	+24V	24V DC		12	+24V	24V DC
	13	RST	CH0 Reset input		13	RST	CH1 Reset input
	14	GND	0V		14	GND	0V
	15	OCA	CH0 Open collector output A		15	OCA	CH1 Open collector output A
	16	GND	0V		16	GND	0V
	17	OCB	CH0 Open collector output B		17	OCB	CH1 Open collector output B
	18	GND	0V		18	GND	0V

■ R7HL-PA2SJ/C

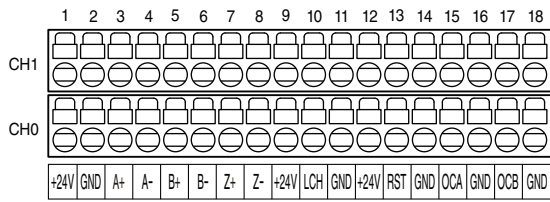

No.	ID	FUNCTION	No.	ID	FUNCTION		
CH0	1	+24V	Encoder excitation output +	CH1	1	+24V	Encoder excitation output +
	2	GND	Encoder excitation output -		2	GND	Encoder excitation output -
	3	A+	CH0 Phase A+		3	A+	CH1 Phase A+
	4	A-	CH0 Phase A-		4	A-	CH1 Phase A-
	5	B+	CH0 Phase B+		5	B+	CH1 Phase B+
	6	B-	CH0 Phase B-		6	B-	CH1 Phase B-
	7	Z+	CH0 Phase Z+		7	Z+	CH1 Phase Z+
	8	Z-	CH0 Phase Z-		8	Z-	CH1 Phase Z-
	9	+24V	24V DC		9	+24V	24V DC
	10	LCH	CH0 Latch input		10	LCH	CH1 Latch input
	11	GND	0V		11	GND	0V
	12	+24V	24V DC		12	+24V	24V DC
	13	RST	CH0 Reset input		13	RST	CH1 Reset input
	14	GND	0V		14	GND	0V
	15	OCA	CH0 Open collector output A		15	OCA	CH1 Open collector output A
	16	GND	0V		16	GND	0V
	17	OCB	CH0 Open collector output B		17	OCB	CH1 Open collector output B
	18	GND	0V		18	GND	0V

■ R7HL-PA2SAx/C

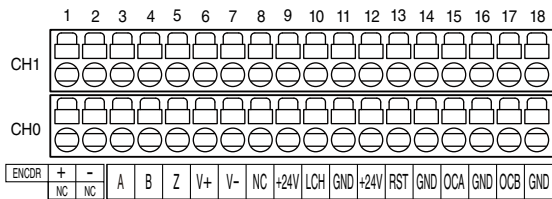

No.	ID	FUNCTION	No.	ID	FUNCTION		
CH0	1	NC	Not used	CH1	1	ENCDR+	Encoder excitation input +
	2	NC	Not used		2	ENCDR-	Encoder excitation input -
	3	A	CH0 Phase A		3	A	CH1 Phase A
	4	B	CH0 Phase B		4	B	CH1 Phase B
	5	Z	CH0 Phase Z		5	Z	CH1 Phase Z
	6	V+	Encoder excitation output +		6	V+	Encoder excitation output +
	7	V-	Encoder excitation output -		7	V-	Encoder excitation output -
	8	NC	Not used		8	NC	Not used
	9	+24V	24V DC		9	+24V	24V DC
	10	LCH	CH0 Latch input		10	LCH	CH1 Latch input
	11	GND	0V		11	GND	0V
	12	+24V	24V DC		12	+24V	24V DC
	13	RST	CH0 Reset input		13	RST	CH1 Reset input
	14	GND	0V		14	GND	0V
	15	OCA	CH0 Open collector output A		15	OCA	CH1 Open collector output A
	16	GND	0V		16	GND	0V
	17	OCB	CH0 Open collector output B		17	OCB	CH1 Open collector output B
	18	GND	0V		18	GND	0V

SCHEMATIC CIRCUITRY

Note: In order to improve EMC performance, bond the FG terminal to ground.

Caution: FG terminal is NOT a protective conductor terminal.

■ R7HL-PA2SJ (RS-422 input, external sensor excitation)

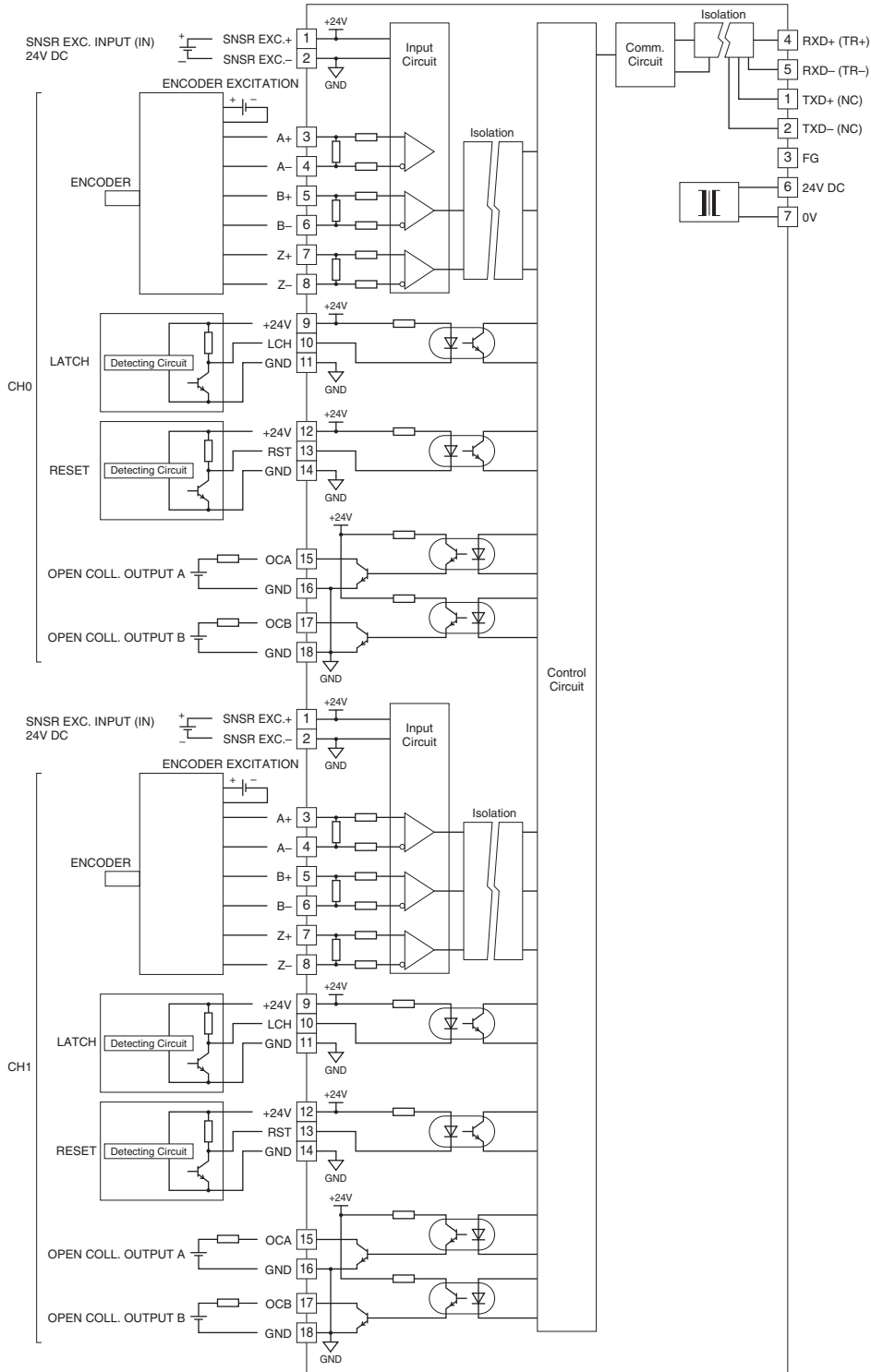

Note 1: Terminal numbers in parentheses are for half-duplex communication model.
 Note 2: For encoder input, use shielded twisted pair cable and the shield line must be grounded.

■ 2-Wire Sensor (LATCH/RESET)

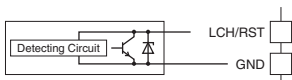

■ R7HL-PA2SA (open collector input, external sensor excitation)

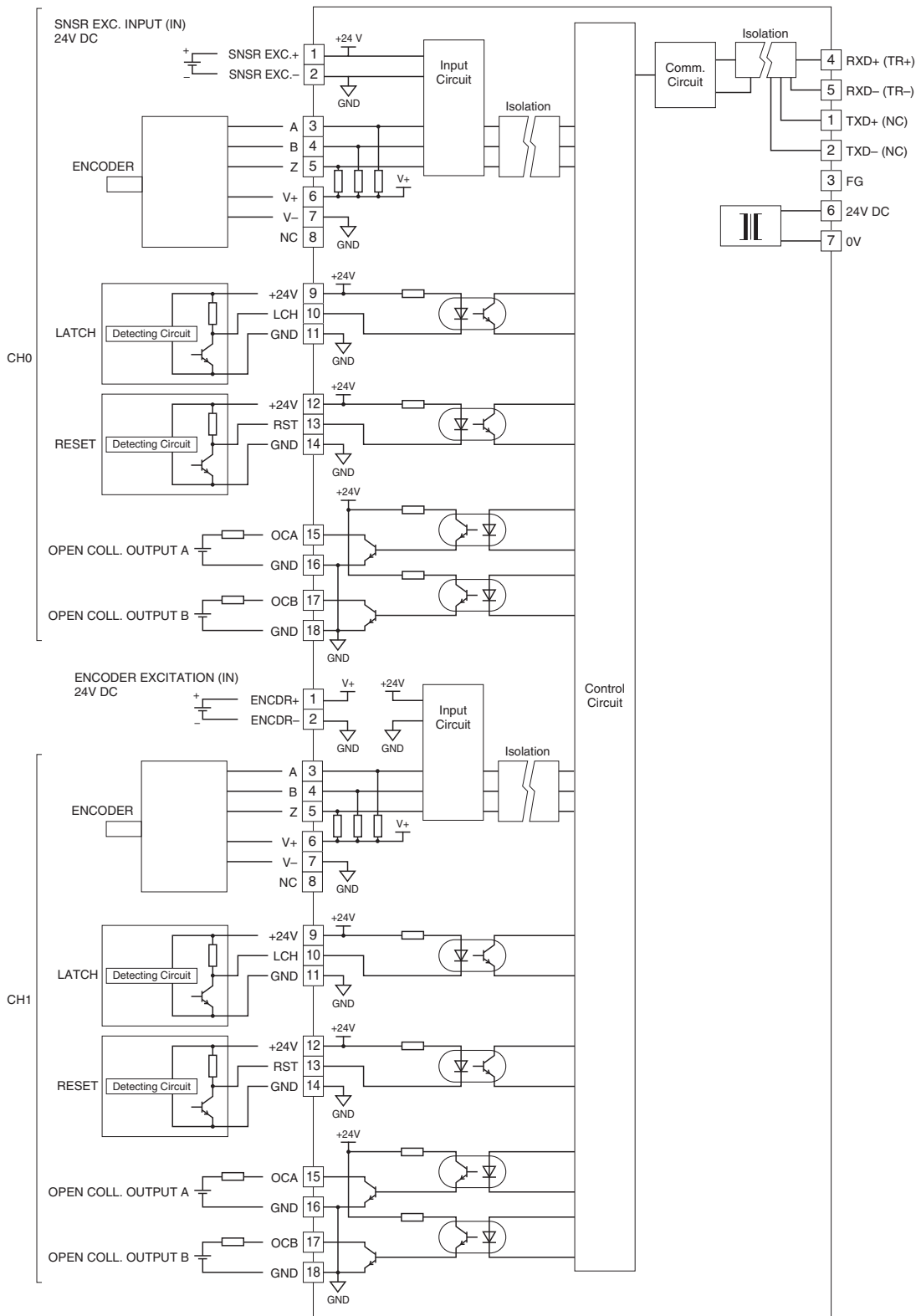

Note 1: Terminal numbers in parentheses are for half-duplex communication model.
 Note 2: For encoder input, use shielded twisted pair cable and the shield line must be grounded.

■ 2-Wire Sensor (LATCH/RESET)

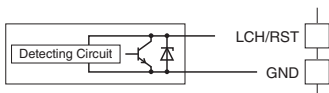

■ R7HL-PA2SJ/C (RS-422 input, sensor excitation available)

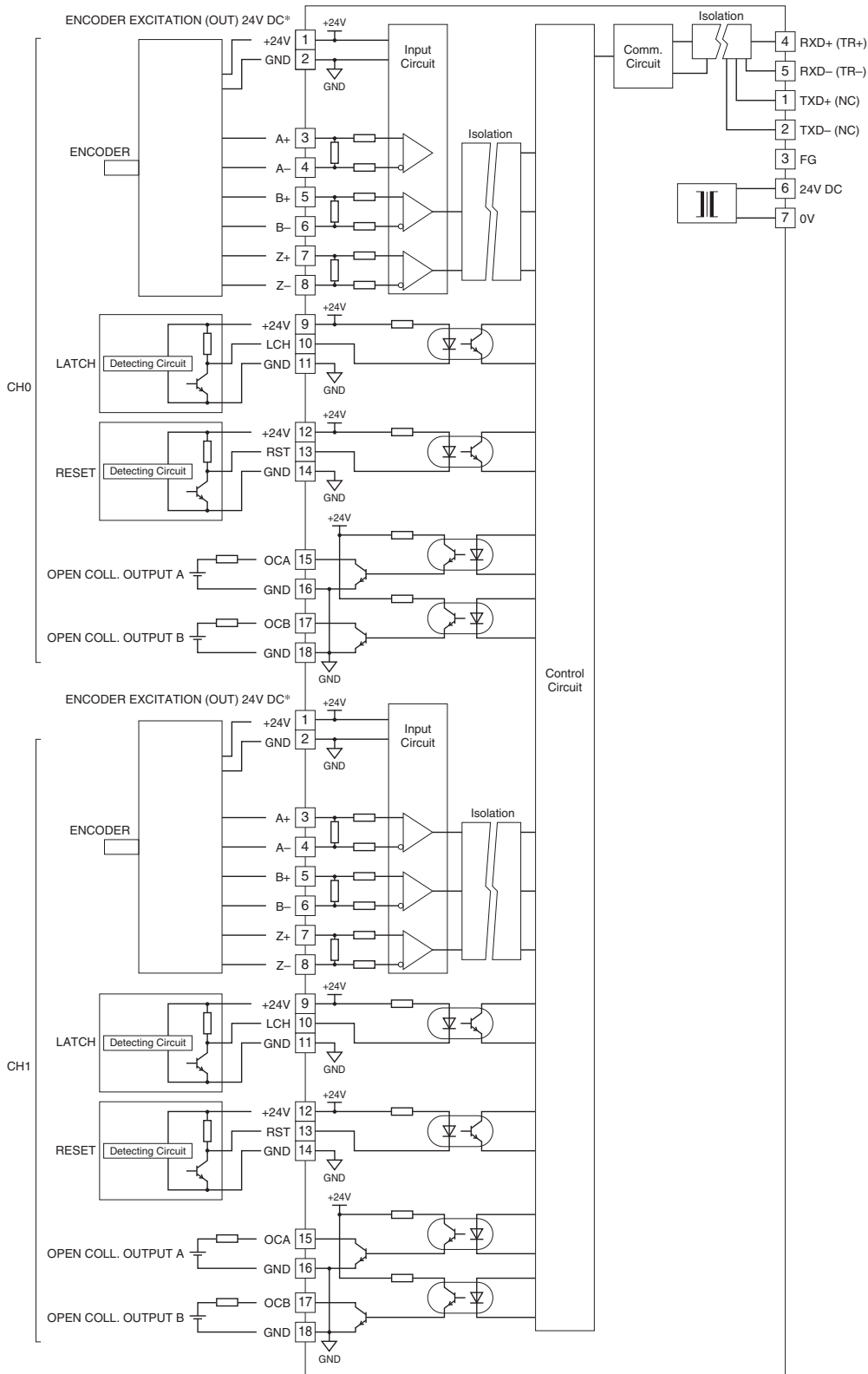

*In case that the encoder's excitation is not 24V DC, prepare an applicable voltage power supply unit.
 Note 1: Terminal numbers in parentheses are for half-duplex communication model.
 Note 2: For encoder input, use shielded twisted pair cable and the shield line must be grounded.

■ 2-Wire Sensor (LATCH/RESET)

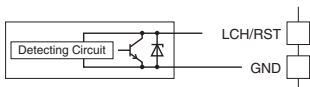

■ R7HL-PA2SA/C (RS-422 input, sensor excitation available)

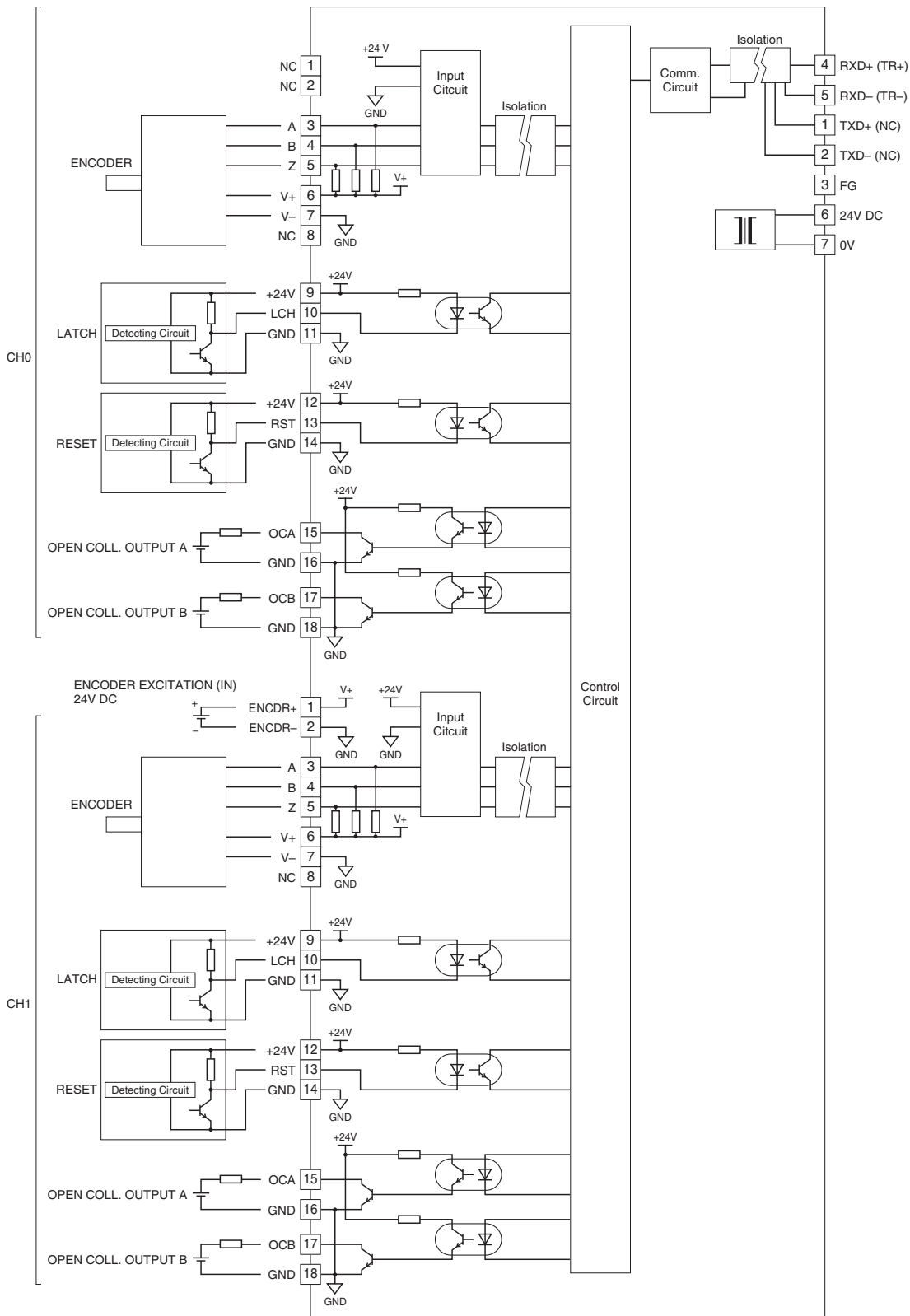

Note 1: Terminal numbers in parentheses are for half-duplex communication model.
 Note 2: For encoder input, use shielded twisted pair cable and the shield line must be grounded.

■ 2-Wire Sensor (LATCH/RESET)

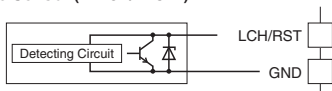

DC VOLTAGE OUTPUT MODULE, 2 points

MODEL: R7HL-YV2

SPECIFICATIONS

Isolation: Output 0 to output 1 to power input to HLS to FG

Data allocation: 2

Converted data range: 0 - 10000 of the output range

Output range

Wide span voltage: -10 - +10 V DC, -5 - +5 V DC,
0 - 10 V DC, 0 - 5 V DC, 1 - 5 V DC

Narrow span voltage: -1 - +1 V DC, 0 - 1 V DC,
-0.5 - +0.5 V DC

Operational range: -15 - +115 % of the output range
(except -10 - +10 V DC);

approx. -11.5 - +11.5 V DC (-10 - +10 V DC)

Load resistance: $\geq 100 \text{ k}\Omega$

Conversion accuracy: $\pm 0.1 \%$

Response time: 250 msec. (0 - 90 %)

Temperature coefficient: $\pm 0.015 \%/^{\circ}\text{C}$ ($\pm 0.008 \%/^{\circ}\text{F}$)

OPERATING MODE SETTING

(*) Factory setting

Caution ! - SW1-1 and SW1-2 are unused. Be sure to turn off unused ones.

• Output Range (SW1-3, 1-4, 1-5, 1-6)

SW1-3	SW1-4	SW1-5	SW1-6	Output range
OFF	OFF	OFF	OFF	-10 - +10V DC (*)
ON	OFF	OFF	OFF	-5 - +5V DC
OFF	ON	OFF	OFF	-1 - +1V DC
ON	ON	OFF	OFF	0 - 10V DC
OFF	OFF	ON	OFF	0 - 5V DC
ON	OFF	ON	OFF	1 - 5V DC
OFF	ON	ON	OFF	0 - 1V DC
ON	ON	ON	OFF	-0.5 - +0.5V DC
ON	ON	ON	ON	PC Configurator setting

• Output at the Loss of Communication (SW1-7)

SW1-7	Output at the loss of communication
OFF	Hold the output (*) (maintains the last data received normally)
ON	Reset the output (to -15% or approx. -11.5 V DC)

• Transfer Rate (SW1-8)

SW1-8	Transfer rate
OFF	12Mbps (*)
ON	6Mbps

TERMINAL ASSIGNMENTS

6	7	8	9	10
NC	VH0	VL0	VH1	VL1
1	2	3	4	5
NC	COM0	COM0	COM1	COM1

NO.	ID	FUNCTION	NO.	ID	FUNCTION
1	NC	No connection	6	NC	No connection
2	COM0	Common 0	7	VH0	Wide span volt. 0
3	COM0	Common 0	8	VL0	Narrow span volt. 0
4	COM1	Common 1	9	VH1	Wide span volt. 1
5	COM1	Common 1	10	VL1	Narrow span volt. 1

CIRCUIT DIAGRAM

Note: In order to improve EMC performance, bond the FG terminal to ground.

Caution: FG terminal is NOT a protective conductor terminal.

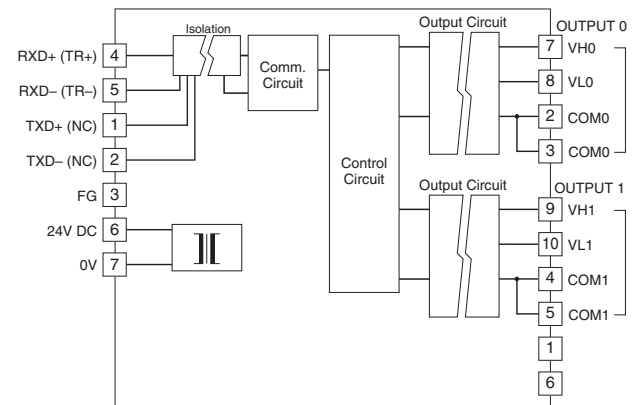

Note: Terminal numbers in parentheses are for half-duplex communication model.

■ Output Connection Examples



DC CURRENT OUTPUT MODULE, 2 points

MODEL: R7HL-YS2

SPECIFICATIONS

Isolation: Output 0 to output 1 to power input to HLS to FG
Data allocation: 2
Converted data range: 0 - 10000 of the output range
Output range: 4 - 20 mA DC
Load resistance: $\leq 600\Omega$
Conversion accuracy: $\pm 0.1\%$
Response time: 250 msec. (0 - 90 %)
Temperature coefficient: $\pm 0.015\%/^{\circ}\text{C}$ ($\pm 0.008\%/^{\circ}\text{F}$)

OPERATING MODE SETTING

(*) Factory setting

Caution ! - SW1-1 through 1-6 are unused. Be sure to turn off unused ones.

• Output at the Loss of Communication (SW1-7)

SW1-7	Output at the loss of communication
OFF	Hold the output (*) (maintains the last data received normally)
ON	Reset the output (to -15%)

• Transfer Rate (SW1-8)

SW1-8	Transfer rate
OFF	12Mbps (*)
ON	6Mbps

TERMINAL ASSIGNMENTS

6	7	8	9	10
NC	I0	NC	I1	NC
1	2	3	4	5
NC	COM0	NC	COM1	NC

NO.	ID	FUNCTION	NO.	ID	FUNCTION
1	NC	No connection	6	NC	No connection
2	COM0	Common 0	7	I0	Current 0
3	NC	No connection	8	NC	No connection
4	COM1	Common 1	9	I1	Current 1
5	NC	No connection	10	NC	No connection

CIRCUIT DIAGRAM

Note: In order to improve EMC performance, bond the FG terminal to ground.

Caution: FG terminal is NOT a protective conductor terminal.

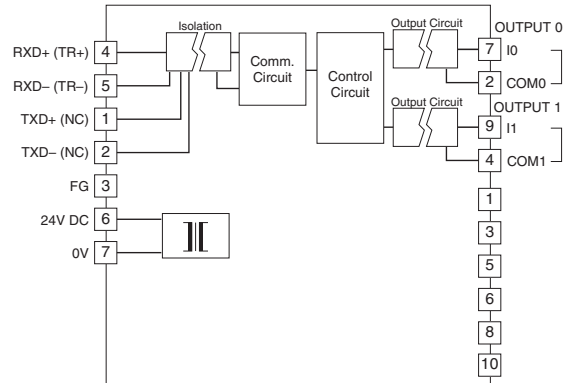

Note: Terminal numbers in parentheses are for half-duplex communication model.

DC VOLTAGE INPUT MODULE

(high speed, 8 points, non-isolated, 12 bits data)

MODEL: R7HL-SVF8NL

SPECIFICATIONS

Isolation: Input to HLS to power input to FG

Data allocation: 1

Converted data range: 0 - 4095 of the input range

Input range: -10 - +10 V DC, -5 - +5 V DC,
0 - 10 V DC, 0 - 5 V DC, 1 - 5 V DC

Input resistance: $\geq 1 \text{ M}\Omega$

Conversion accuracy: $\pm 0.1 \%$

Conversion rate: 2.5 msec. / channel

Response time: Conversion rate \times 8 msec. (0 - 90 %)

Temperature coefficient: $\pm 0.015 \%/^{\circ}\text{C}$ ($\pm 0.008 \%/^{\circ}\text{F}$)

OPERATING MODE SETTING

(*) Factory setting

Caution ! - SW1-1, SW1-2 and SW1-7 are unused. Be sure to turn off unused ones.

• Input Range (SW1-3, 1-4, 1-5, 1-6)

SW1-3	SW1-4	SW1-5	SW1-6	Input range
OFF	OFF	OFF	OFF	-10 - +10V DC (*)
ON	OFF	OFF	OFF	-5 - +5V DC
ON	ON	OFF	OFF	0 - 10V DC
OFF	OFF	ON	OFF	0 - 5V DC
ON	OFF	ON	OFF	1 - 5V DC
ON	ON	ON	ON	PC Configurator setting

• Transfer Rate (SW1-8)

SW1-8	Transfer rate	
	Option code: NONE	Option code: /3
OFF	12 Mbps (*)	3 Mbps
ON	6 Mbps	Unused

TERMINAL ASSIGNMENTS

10	11	12	13	14	15	16	17	18
V0	V1	V2	V3	NC	V4	V5	V6	V7
1	2	3	4	5	6	7	8	9
COM0	COM1	COM2	COM3	NC	COM4	COM5	COM6	COM7

NO.	ID	FUNCTION	NO.	ID	FUNCTION
1	COM0	Common 0	10	V0	Voltage Input 0
2	COM1	Common 1	11	V1	Voltage Input 1
3	COM2	Common 2	12	V2	Voltage Input 2
4	COM3	Common 3	13	V3	Voltage Input 3
5	NC	No connection	14	NC	No connection
6	COM4	Common 4	15	V4	Voltage Input 4
7	COM5	Common 5	16	V5	Voltage Input 5
8	COM6	Common 6	17	V6	Voltage Input 6
9	COM7	Common 7	18	V7	Voltage Input 7

CIRCUIT DIAGRAM

Note: In order to improve EMC performance, bond the FG terminal to ground.

Caution: FG terminal is NOT a protective conductor terminal.

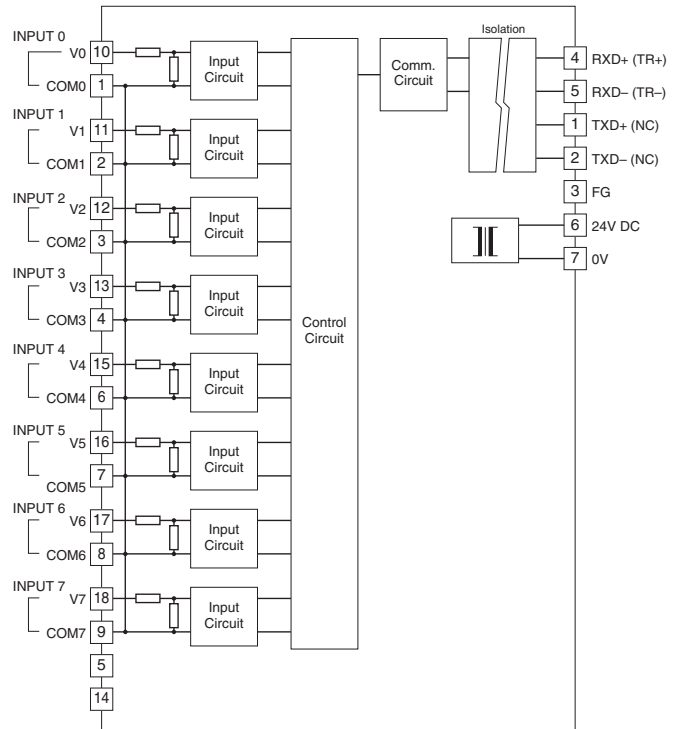

Note: Terminal numbers in parentheses are for half-duplex communication model.

DC VOLTAGE OUTPUT MODULE

(4 points, isolated, 12 bits data)

MODEL: R7HL-YV4L

SPECIFICATIONS

Isolation: Output 0 to output 1 to output 2 to output 3 to HLS to power input to FG

Data allocation: 1

Converted data range: 0 - 4095 of the output range

Output rang: -10 - +10V DC, -5 - +5V DC, 0 - 10V DC, 0 - 5V DC, 1 - 5V DC

Operational range: 0 - 100 % of the output range

Load resistance: $\geq 100 \text{ k}\Omega$

Conversion accuracy: $\pm 0.1 \%$

Response time: 250 msec. (0 - 90 %)

Temperature coefficient: $\pm 0.015 \%/^{\circ}\text{C}$ ($\pm 0.008 \%/^{\circ}\text{F}$)

OPERATING MODE SETTING

(*) Factory setting

Caution ! - SW1-1 and SW1-2 are unused. Be sure to turn off unused ones.

• Output Range (SW1-3, 1-4, 1-5, 1-6)

SW1-3	SW1-4	SW1-5	SW1-6	Output range
OFF	OFF	OFF	OFF	-10 – +10V DC (*)
ON	OFF	OFF	OFF	-5 – +5V DC
ON	ON	OFF	OFF	0 – 10V DC
OFF	OFF	ON	OFF	0 – 5V DC
ON	OFF	ON	OFF	1 – 5V DC
ON	ON	ON	ON	PC Configurator setting

• Output at the Loss of Communication (SW1-7)

SW1-7	Output at the loss of communication
OFF	Hold the output (*) (maintains the last data received normally)
ON	Reset the output (fixed to 0%)

• Transfer Rate (SW1-8)

SW1-8	Transfer rate	
	Option code: NONE	Option code: /3
OFF	12 Mbps (*)	3 Mbps
ON	6 Mbps	Unused

TERMINAL ASSIGNMENTS

6	7	8	9	10
NC	V0	V1	V2	V3
1	2	3	4	5
NC	COM0	COM1	COM2	COM3

NO.	ID	FUNCTION	NO.	ID	FUNCTION
1	NC	No connection	6	NC	No connection
2	COM0	Common 0	7	V0	Voltage Output 0
3	COM1	Common 1	8	V1	Voltage Output 1
4	COM2	Common 2	9	V2	Voltage Output 2
5	COM3	Common 3	10	V3	Voltage Output 3

CIRCUIT DIAGRAM

Note: In order to improve EMC performance, bond the FG terminal to ground.

Caution: FG terminal is NOT a protective conductor terminal.

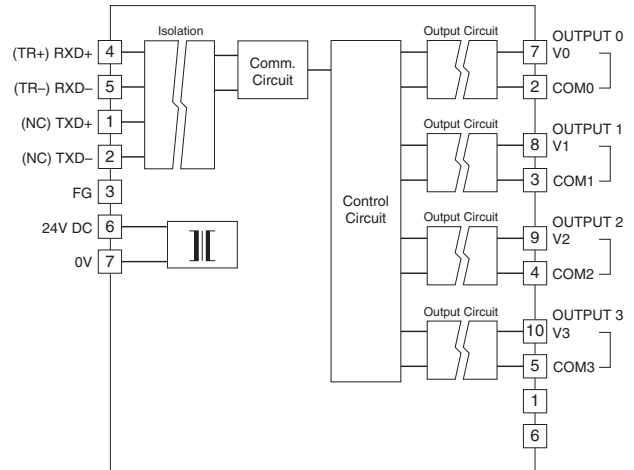

Note: Terminal numbers in parentheses are for half-duplex communication model.



Specifications are subject to change without notice.