

## Remote I/O R7 Series

### FLEX NETWORK I/O MODULE

(Thermocouple input, 4 points, isolated)

#### Functions & Features

- 4 points thermocouple input module for FLEX NETWORK
- Input sensor can be selected with the front DIP switches for all channels.
- Easy parameter setting of individual channels with M-System's configurator software

FLEX NETWORK is registered trademark of Digital Electronics Corporation in Japan.

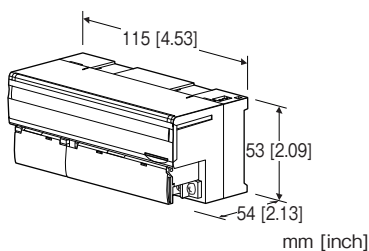

### MODEL: R7FN-TS4-R[1]

#### ORDERING INFORMATION

- Code number: R7FN-TS4-R[1]  
Specify a code from below for [1].  
(e.g. R7FN-TS4-R/Q)
- Specify the specification for option code /Q  
(e.g. /C01/SET)

#### I/O TYPE

**TS4:** Thermocouple input, 4 points

#### POWER INPUT

##### DC Power

R: 24 V DC

(Operational voltage range 24 V  $\pm$ 10 %, ripple 10 %p-p max.)

#### [1] OPTIONS

blank: none

/Q: Options other than the above (specify the specification)

#### SPECIFICATIONS OF OPTION: Q (multiple selections)

**COATING (For the detail, refer to M-System's web site.)**

/C01: Silicone coating

/C02: Polyurethane coating

/C03: Rubber coating

#### EX-FACTORY SETTING

/SET: Preset according to the Ordering Information Sheet  
(No. ESU-7808-TS4)

#### RELATED PRODUCTS

- PC configurator software (model: R7CON)

The configurator software is downloadable at M-System's web site.

A dedicated cable is required to connect the module to the PC. Please refer to the internet software download site or the users manual for the PC configurator for applicable cable types.

- Screen editor software (model: GP-Pro EX)

Screen editor software GP-Pro EX (Ver.2.70 or higher) is available.

For versions between 2.60 and 2.70, the driver must be installed. The driver is downloadable at Digital Electronics Corporation's web site. <http://www.proface.co.jp/>

#### GENERAL SPECIFICATIONS

**Connection:** M3 separable screw terminal (torque 0.5 N·m)

**Solderless terminal:** Refer to the drawing at the end of the section.

- **Communication cable**

**Recommended manufacture:** Japan Solderless Terminal MFG.Co.Ltd

**Applicable wire size:** 0.2 to 0.5 mm<sup>2</sup> (AWG 26 to 22)

- **Others**

**Recommended manufacture:** Japan solderless terminal MFG.Co.Ltd, Nichifu Co.,Ltd

**Applicable wire size:** 0.25 to 1.65 mm<sup>2</sup> (AWG 22 to 16)

**Screw terminal:** Nickel-plated steel

**Housing material:** Flame-resistant resin (gray)

**Isolation:** Input 0 to input 1 to input 2 to input 3 to FLEX NETWORK to power to FG

**Zero adjustments:** Configurable via R7CON

**Span adjustments:** Configurable via R7CON

**Conversion rate:** Configurable via R7CON

**Thermocouple setting:** Configurable via the front DIP switch or R7CON

**Burnout setting:** Selectable between upscale (\*) and downscale with the front DIP switch

(\*) Factory default setting

**Linearization:** Standard

**Cold junction compensation:** CJC sensor attached to the input terminals

**Status indicator LED:** PWR, RUN

(Refer to the instruction manual)

## Recommended solderless terminal

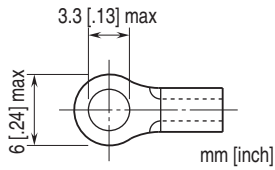

## FLEX NETWORK COMMUNICATION

**Communication configuration:** 1: N

**Connection method:** Multi-drop Connection

**Communication method:** Cyclic Time Division, half-duplex

**Communication I/F:** Differential, pulse transfer isolation

**Error Check:** Format, bit, CRC-12 verification

**Max. Number of Nodes:** 63 (1008 I/O points)

**Required node:** 4

**Network cable:** Pro-face's following cable

FN-CABLE2010-31-MS (10 m)

FN-CABLE2050-31-MS (50 m)

FN-CABLE2200-31-MS (200 m)

**Transmission distance:** 12 Mbps: 100 meters (328 ft)(\*)

6 Mbps: 200 meters (656 ft)

(\*) Factory default setting

**Station address:** Rotary switch

(Refer to the instruction manual)

**Terminating resistor:** Built-in

## INPUT SPECIFICATIONS

**Input resistance:** 30 kΩ min.

**Burnout sensing:** 0.1 μA

T/C	BURNOUT INDICATION (°C)		CONFORMANCE RANGE (°C)
	Downscale	Upscale	
K (CA)	-272	+1472	-150 to +1370
E (CRC)	-272	+1120	-170 to +1000
J (IC)	-260	+1300	-180 to +1200
T (CC)	-272	+ 500	-170 to + 400
B (RH)	24	1920	400 to 1760
R	-100	+1860	200 to 1760
S	-100	+1860	0 to 1760
C (WRe 5-26)	-52	+2416	0 to 2315
N	-272	+1400	-130 to +1300
U	-252	+ 700	-200 to +600
L	-252	+1000	-200 to +900
P (Platinel II)	-52	+1496	0 to 1395
(PR)	-52	+1860	0 to 1760

T/C	BURNOUT INDICATION (°F)		CONFORMANCE RANGE (°F)
	Downscale	Upscale	
K (CA)	-458	+2682	-238 to +2498
E (CRC)	-458	+2048	-274 to +1832
J (IC)	-436	+2372	-292 to +2192
T (CC)	-458	+932	-274 to +752
B (RH)	75	3488	752 to 3200
R	-148	+3380	392 to 3200
S	-148	+3380	32 to 3200
C (WRe 5-26)	-62	+4381	32 to 4199
N	-458	+2552	-202 to +2372
U	-422	+1292	-328 to +1112
L	-422	+1832	-328 to +1652
P (Platinel II)	-62	+2725	32 to 2543
(PR)	-62	+3380	32 to 3200

## INSTALLATION

**Current consumption**

•DC: Approx. 90 mA

**Operating temperature:** -10 to +55°C (14 to 131°F)

**Storage temperature:** -20 to +65°C (-4 to +149°F)

**Operating humidity:** 30 to 90 %RH (non-condensing)

**Atmosphere:** No corrosive gas or heavy dust

**Mounting:** DIN rail (35 mm rail)

**Weight:** 200 g (0.44 lb)

## PERFORMANCE

**Conversion accuracy:** ±1°C (±1.8°F) except ±2°C (±3.6°F) for B, R, S, C, PR

**Conversion rate:** 250 msec. (\*) or 500 msec. selectable  
(\*) Factory default setting

**Converted data range:**

- Engineering unit value (°C, K) × 10 (integer)
- Engineering unit value (°F)

**Cold junction compensation error:**

±1°C max. (at 25°C ±10°C)  
 ±1.8°F max. (at 77°F ±18°F)  
 (±1.5°C or ±2.7°F for R, S, PR)  
**Temp. coefficient:** ±0.015 %/°C (±0.008 %/°F) of max. span  
**Response time:** Conversion rate × 2 + 50 msec. (0 - 90 %)  
**Insulation resistance:** ≥ 100 MΩ with 500 V DC  
**Dielectric strength:** 1500 V AC @ 1 minute (input 0 to input 1 to input 2 to input 3 to FLEX NETWORK to power to FG)

## STANDARDS & APPROVALS

**EU conformity:**  
 EMC Directive  
 EMI EN 61000-6-4  
 EMS EN 61000-6-2  
 RoHS Directive

## EXTERNAL VIEW

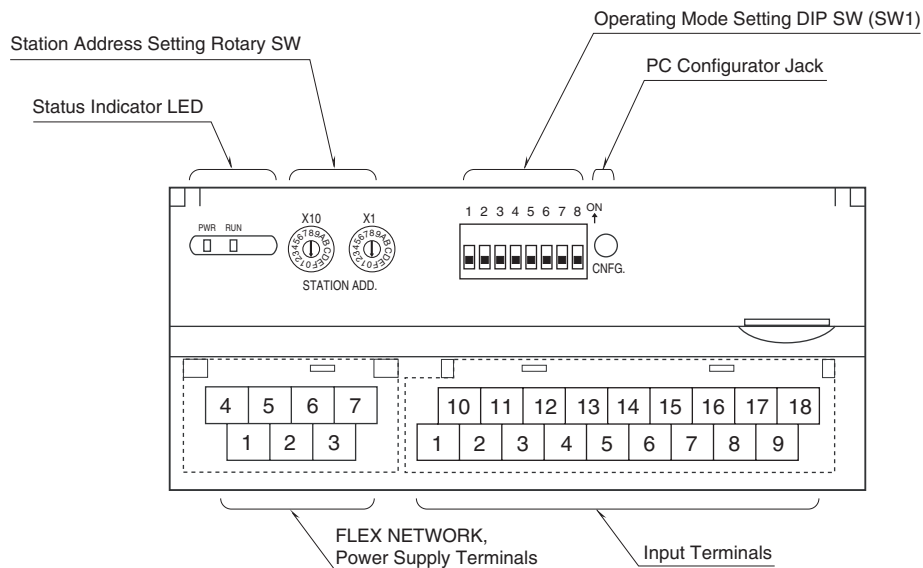

## CONNECTION DIAGRAMS

### ■ MASTER CONNECTION

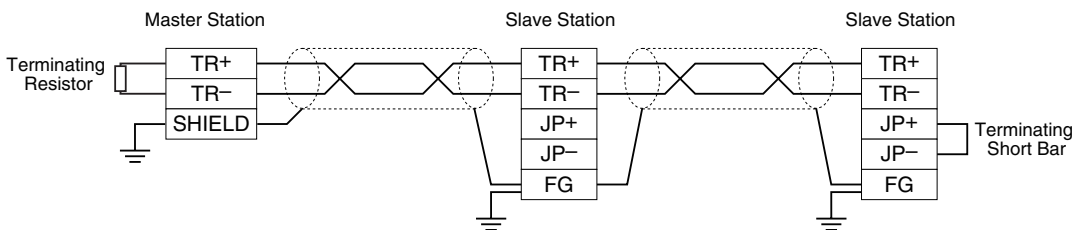

Note: Be sure to use the terminator(s) located at both ends of the modules.

## TERMINAL ASSIGNMENTS

### ■ INPUT TERMINAL ASSIGNMENT

10	11	12	13	14	15	16	17	18
+IN0	-IN0	+IN1	-IN1	NC	+IN2	-IN2	+IN3	-IN3
1	2	3	4	5	6	7	8	9
+CJ0	-CJ0	+CJ1	-CJ1	NC	+CJ2	-CJ2	+CJ3	-CJ3

NO.	ID	FUNCTION	NO.	ID	FUNCTION
1	+CJ0	CJC + 0	10	+IN0	T/C + 0
2	-CJ0	CJC - 0	11	-IN0	T/C - 0
3	+CJ1	CJC + 1	12	+IN1	T/C + 1
4	-CJ1	CJC - 1	13	-IN1	T/C - 1
5	NC	No connection	14	NC	No connection
6	+CJ2	CJC + 2	15	+IN2	T/C + 2
7	-CJ2	CJC - 2	16	-IN2	T/C - 2
8	+CJ3	CJC + 3	17	+IN3	T/C + 3
9	-CJ3	CJC - 3	18	-IN3	T/C - 3

### ■ NETWORK, POWER SUPPLY TERMINAL ASSIGNMENT

4	5	6	7
TR+	TR-	+24V	0V
1	2	3	
JP+	JP-	FG	

NO.	ID	FUNCTION, NOTES
1	JP+	Terminating resistor
2	JP-	Terminating resistor
3	FG	FG
4	TR+	Network
5	TR-	Network
6	+24V	Power input (24V DC)
7	0V	Power input (0V)

## DATA CONVERSION

### ■ INPUT RANGE AND DATA CONVERSION (FACTORY DEFAULT SETTING)

Engineering unit value °C or K is multiplied by 10 and expressed in 16 bits. °F data is represented in engineering unit value, without multiplication. Negative value is represented in 2's complements.

• Input TYPE K Thermocouple		
Input Value	Converted Data, Decimal	Converted Data, Hex
≤ -272°C	-2720	F560
-150°C	-1500	FA24
1370°C	13700	3584
≥ 1472°C	14720	3980

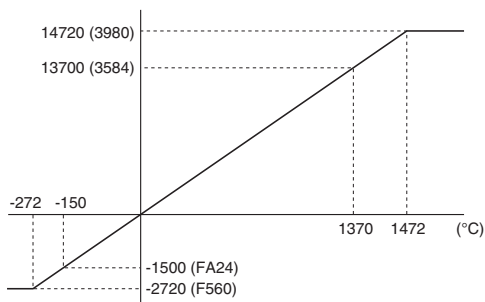

## I/O DATA DESCRIPTIONS

### ■ ANALOG INPUT

#### • Di



#### • Do

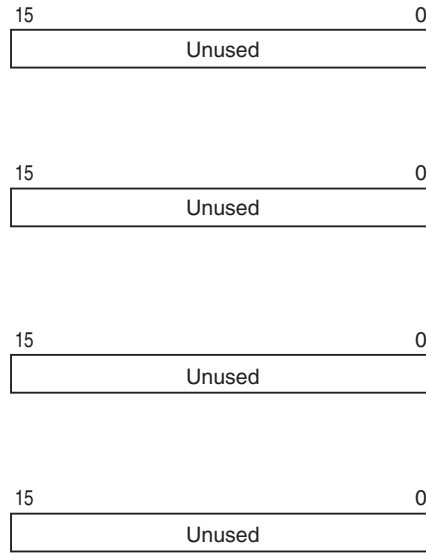

The data is 16-bit binary.  
Negative value is represented in 2's complements.

## EXTERNAL DIMENSIONS & TERMINAL ASSIGNMENTS unit: mm [inch]

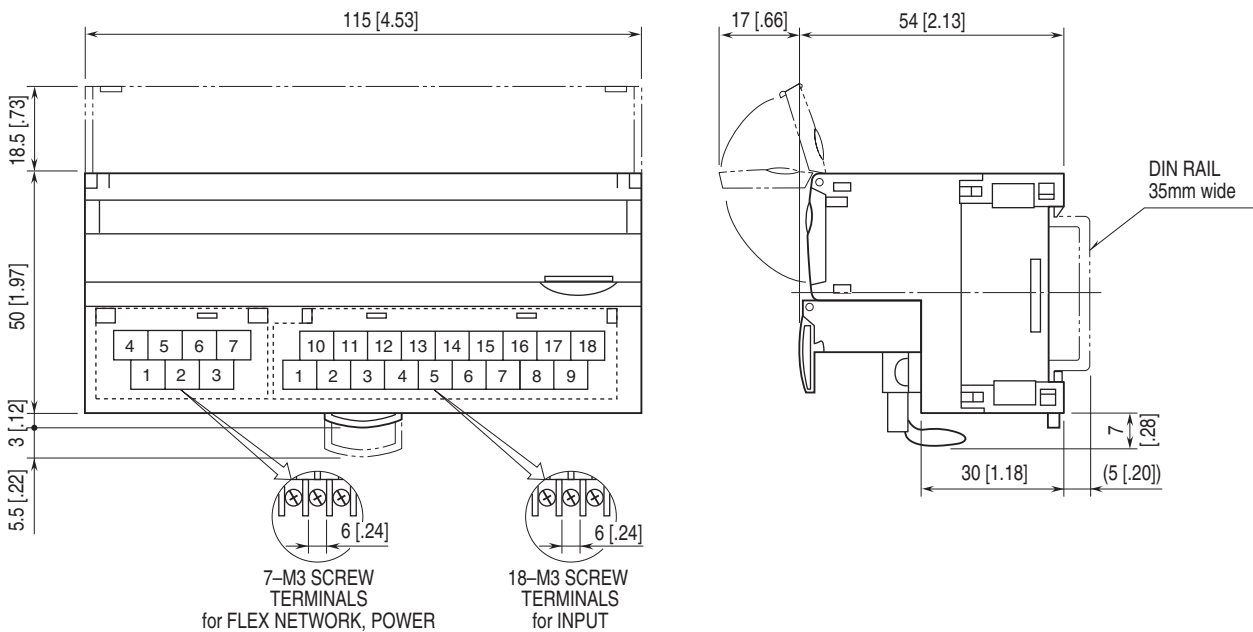

## SCHEMATIC CIRCUITRY & CONNECTION DIAGRAM

Note: In order to improve EMC performance, bond the FG terminal to ground.

Caution: FG terminal is NOT a protective conductor terminal.

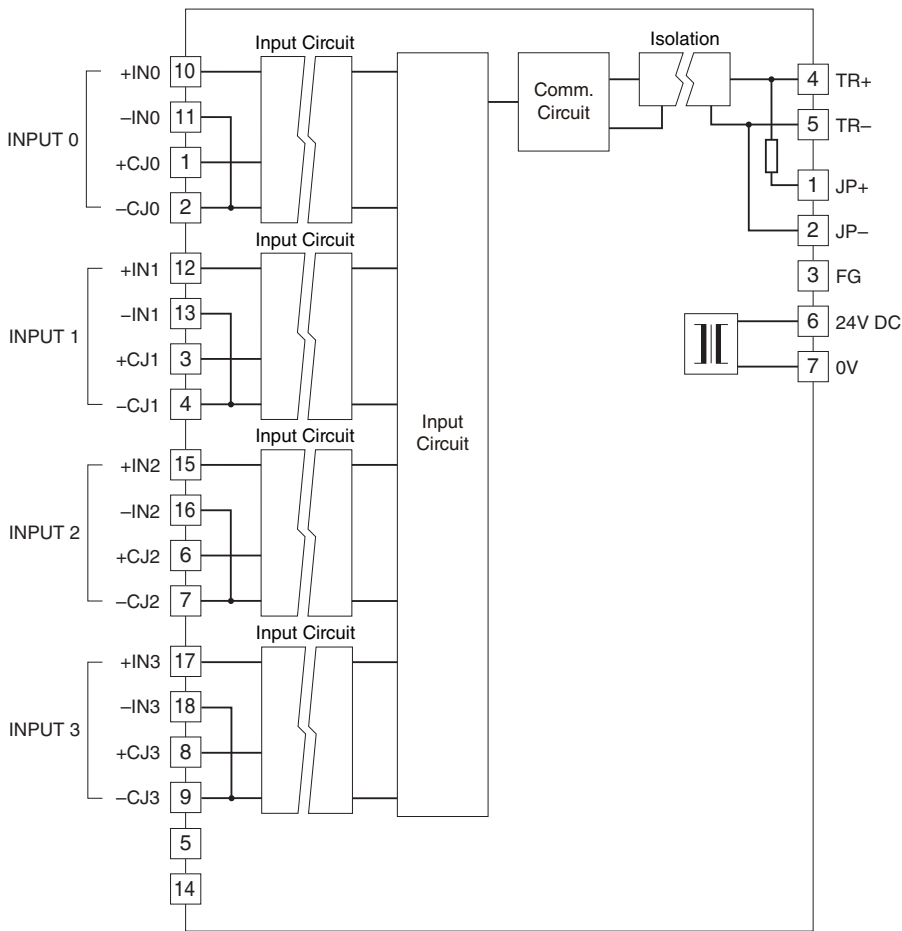

### Input Connection Example

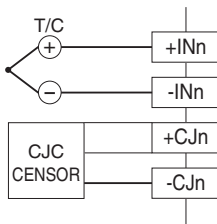

Specifications are subject to change without notice.