

Remote I/O R7 Series

FLEX NETWORK I/O MODULE

(16 points NPN transistor output)

Functions & Features

- 16 points NPN transistor output module for FLEX NETWORK

FLEX NETWORK is registered trademark of Digital Electronics Corporation in Japan.

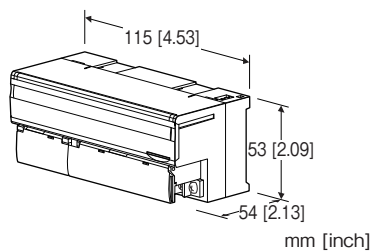

MODEL:R7FN-DC16A-R[1]

ORDERING INFORMATION

- Code number: R7FN-DC16A-R[1]
Specify a code from below for [1].
(e.g. R7FN-DC16A-R/Q)
- Specify the specification for option code /Q
(e.g. /C01/SET)

I/O TYPE

DC16A: NPN transistor output, 16 points

POWER INPUT

DC Power

R: 24 V DC

(Operational voltage range 24 V \pm 10 %, ripple 10 %p-p max.)

[1] OPTIONS

blank: none

/Q: Options other than the above (specify the specification)

SPECIFICATIONS OF OPTION: Q (multiple selections)

COATING (For the detail, refer to M-System's web site.)

/C01: Silicone coating

/C02: Polyurethane coating

/C03: Rubber coating

EX-FACTORY SETTING

/SET: Preset according to the Ordering Information Sheet

(No. ESU-7808-DC16)

GENERAL SPECIFICATIONS

Connection: M3 separable screw terminal (torque 0.5 N·m)
Solderless terminal: Refer to the drawing at the end of the section.

• Communication cable

Recommended manufacture: Japan Solderless Terminal MFG.Co.Ltd

Applicable wire size: 0.2 to 0.5 mm² (AWG 26 to 22)

• Others

Recommended manufacture: Japan solderless terminal MFG.Co.Ltd, Nichifu Co.,Ltd

Applicable wire size: 0.25 to 1.65 mm² (AWG 22 to 16)

Screw terminal: Nickel-plated steel

Housing material: Flame-resistant resin (gray)

Isolation: Output to FLEX NETWORK to power to FG

Output at the loss of communication:

Output hold (*), Output clear

Selectable with the front DIP SW

(*) factory default setting

Status indicator LED: PWR, RUN

(Refer to the instruction manual)

Discrete output status indicator LED: LED turns on with output ON

■ Recommended solderless terminal

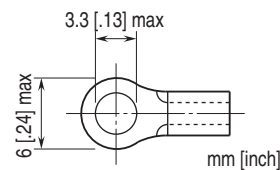

FLEX NETWORK COMMUNICATION

Communication configuration: 1: N

Connection method: Multi-drop Connection

Communication method: Cyclic Time Division, half-duplex

Communication I/F: Differential, pulse transfer isolation

Error Check: Format, bit, CRC-12 verification

Max. Number of Nodes: 63 (1008 I/O points)

Required node: 1

Network cable: Pro-face's following cable

FN-CABLE2010-31-MS (10 m)

FN-CABLE2050-31-MS (50 m)

FN-CABLE2200-31-MS (200 m)

Transmission distance: 12 Mbps: 100 meters (328 ft) (*)

6 Mbps: 200 meters (656 ft)

(*) Factory default setting

Station address: Rotary switch

(Refer to the instruction manual)

Terminating resistor: Built-in

OUTPUT SPECIFICATIONS

Common: Negative common (NPN) per 16 points
Maximum outputs applicable at once: No limit (at 24 V DC)
Rated load voltage: 24 V DC $\pm 10\%$
Rated output current: 0.25 A per point, 2.0 A per common
Residual voltage: ≤ 1.2 V
Leakage current: ≤ 0.1 mA
ON delay: ≤ 0.5 msec.
OFF delay: ≤ 1.5 msec.
 (When driving an inductive load, connect a diode in parallel with the load.)

INSTALLATION

Current consumption
 •DC: Approx. 50 mA
Operating temperature: -10 to +55°C (14 to 131°F)
Storage temperature: -20 to +65°C (-4 to +149°F)
Operating humidity: 30 to 90 %RH (non-condensing)
Atmosphere: No corrosive gas or heavy dust
Mounting: DIN rail (35 mm rail)
Weight: 200 g (0.44 lb)

PERFORMANCE

Insulation resistance: ≥ 100 M Ω with 500 V DC
Dielectric strength: 1500 V AC @ 1 minute (output to FLEX NETWORK to power to FG)

STANDARDS & APPROVALS

EU conformity:
 EMC Directive
 EMI EN 61000-6-4
 EMS EN 61000-6-2
 RoHS Directive

EXTERNAL VIEW

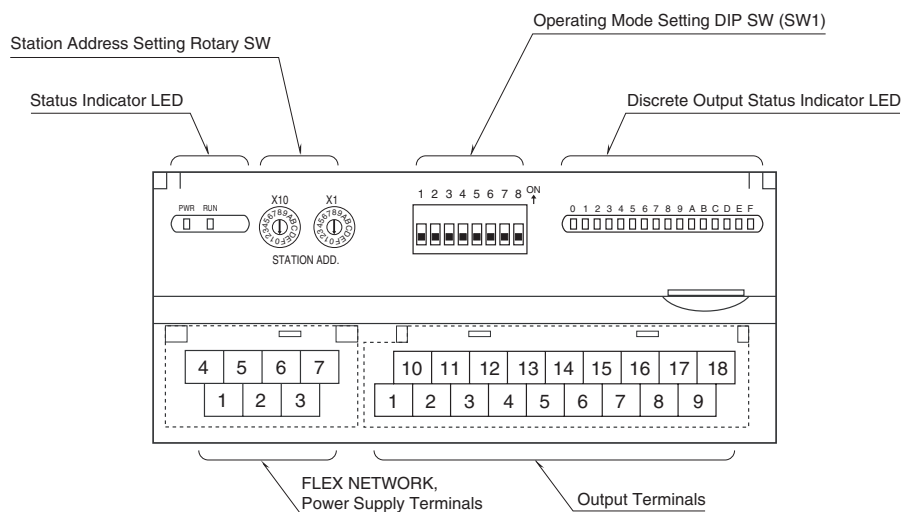

CONNECTION DIAGRAMS

■ MASTER CONNECTION

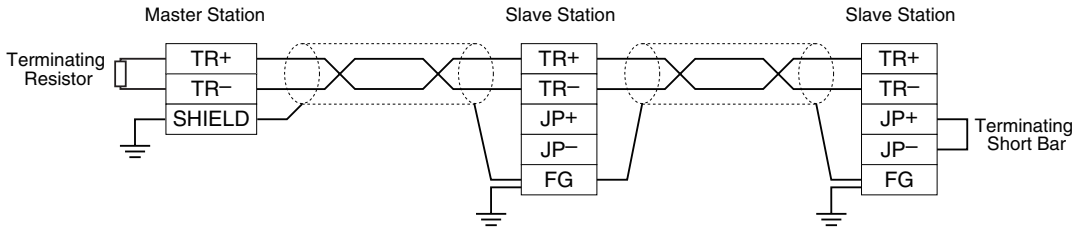

Note: Be sure to use the terminator(s) located at both ends of the modules.

TERMINAL ASSIGNMENTS

■ OUTPUT TERMINAL ASSIGNMENT

10	11	12	13	14	15	16	17	18
+24V	Y1	Y3	Y5	Y7	Y9	YB	YD	YF
1	2	3	4	5	6	7	8	9
0V	Y0	Y2	Y4	Y6	Y8	YA	YC	YE

NO.	ID	FUNCTION	NO.	ID	FUNCTION
1	0 V	0 V (common)	10	+24 V	24 V DC
2	Y0	Output 0	11	Y1	Output 1
3	Y2	Output 2	12	Y3	Output 3
4	Y4	Output 4	13	Y5	Output 5
5	Y6	Output 6	14	Y7	Output 7
6	Y8	Output 8	15	Y9	Output 9
7	YA	Output 10	16	YB	Output 11
8	YC	Output 12	17	YD	Output 13
9	YE	Output 14	18	YF	Output 15

■ NETWORK, POWER SUPPLY TERMINAL ASSIGNMENT

4	5	6	7
TR+	TR-	+24V	0V
1	2	3	
JP+	JP-	FG	

NO.	ID	FUNCTION, NOTES
1	JP+	Terminating resistor
2	JP-	Terminating resistor
3	FG	FG
4	TR+	Network
5	TR-	Network
6	+24V	Power input (24V DC)
7	0V	Power input (0V)

I/O DATA DESCRIPTIONS

■ DISCRETE OUTPUT

• Di

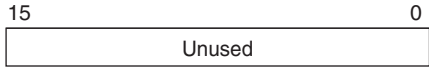

• Do

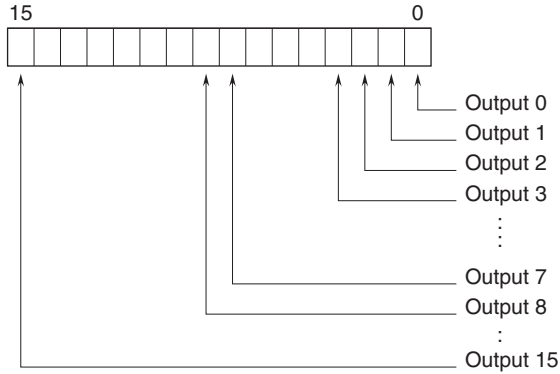

0: OFF
1: ON

EXTERNAL DIMENSIONS & TERMINAL ASSIGNMENTS unit: mm [inch]

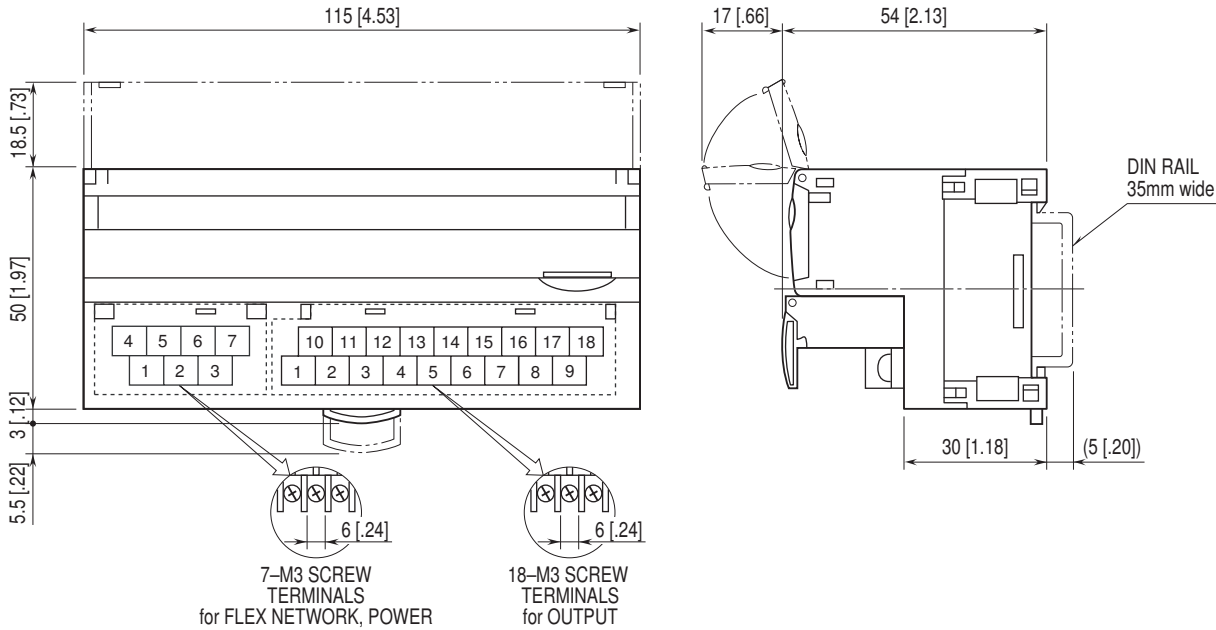

SCHEMATIC CIRCUITRY & CONNECTION DIAGRAM

Note: In order to improve EMC performance, bond the FG terminal to ground.
 Caution: FG terminal is NOT a protective conductor terminal.

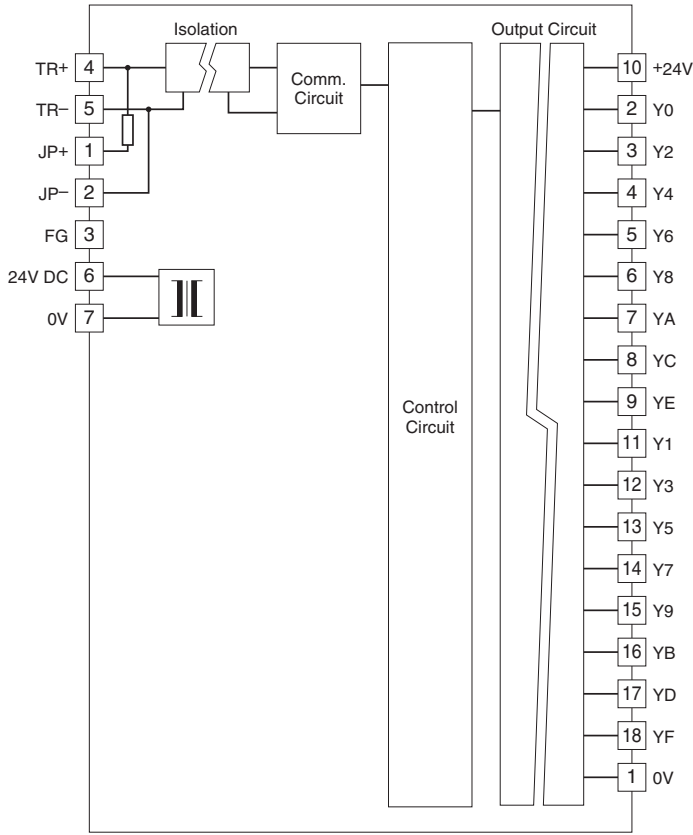

Output Circuit

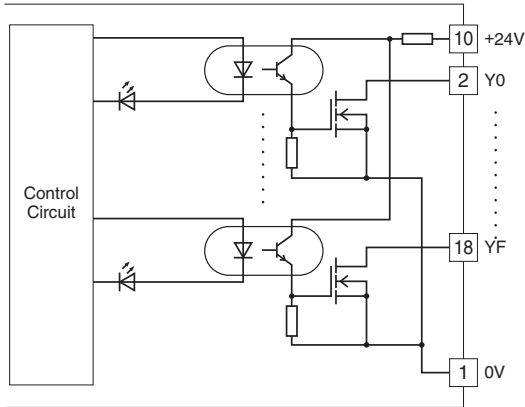

Output Connection Example

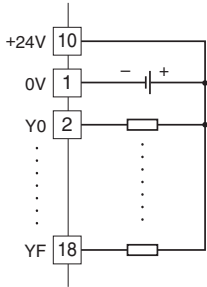



Specifications are subject to change without notice.