

Final Control Elements

SERVO-TOP II ELECTRONIC ACTUATOR

(rotary type; max. torque 600 N·m)

Functions & Features

- Control valve actuator drive
- Friendly user interface
- High resolution stepping motor
- With manual hand wheel (which does not rotate during operation)

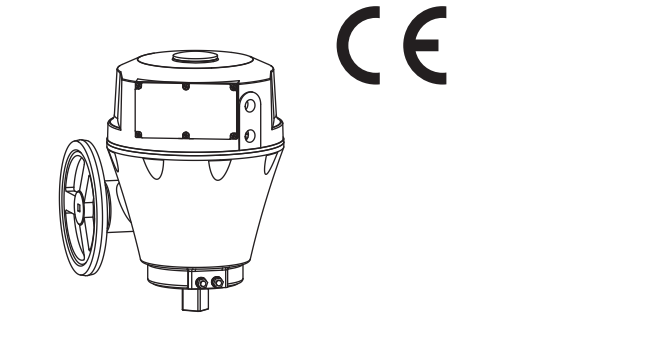

MODEL: PRP-2-[1][2]-[3]

ORDERING INFORMATION

- Code number: PRP-2-[1][2]-[3]
- Specify a code from below for each of [1] through [3].
(e.g. PRP-2-1A-K3)
- Use Ordering Information Sheet (No. ESU-4875). Factory setting (table below) will be used if not otherwise specified.

STANDARD FACTORY SETTING

PARAMETER	FACTORY SETTING
Action	Reverse
Operation at input failure	Hold position at input failure
Output stem position at full-closed	0°
Output stem position at full-open	90°
Ex-factory stem position	90°
Full-closed (0°) signal position	ON at 2° or less
Full-open (90°) signal position	ON at 88° or more
Restart limiting timer	2 sec.
Resolution	1/300 [output stem operational angle: 0.3°]

[1] TORQUE, OPERATION TIME

- 1: 600 Nm, 50 sec./90°
- 2: 600 Nm, 34 sec./90°
- 3: 600 Nm, specified time (refer to the instruction manual)

[2] INPUT

Current

A: 4 - 20 mA DC (Input resistance 250 Ω)

Voltage

6: 1 - 5 V DC (Input resistance 20 kΩ min.)

[3] POWER SUPPLY VOLTAGE

AC Power

K3: 100 - 120 V AC

(Operational voltage range 90 - 132 V, 47 - 66 Hz)
(Not selectable for CE)

L3: 200 - 240 V AC

(Operational voltage range 180 - 264 V, 47 - 66 Hz)

RELATED PRODUCTS (Products sold separately)

- Programming Unit (model: PU-2x)

GENERAL SPECIFICATIONS

Degree of protection: IP66

Action: Reverse or direct (In "reverse" action, the output stem turns counterclockwise (seen from the indicator) with an input signal increase.)

Field selectable with DIP switches

Operation at input failure: Stem stop at full-open, full-close or hold position at input failure; field selectable with DIP switches

Minimum input signal

Current input: ≥ 2.0 mA DC

Voltage input: ≥ 0.5 V DC

Wiring conduits: G 1/2 female thread (two)

Terminal block: 8.4 mm pitch; M3.5 screw terminals (torque 0.7 to 1.1 N·m)

Housing material: Aluminum alloy (type: ADC12)

Coating: Baked acrylic resin

Drive: Stepping motor

Insulation class: E

Position detection: Potentiometer (conductive plastic type)

Full-open and full-closed positions: -5 to +95°; minimum span 45°; field adjustable with control buttons

Full-closed signal adj.: -5 to +20°

Full-open signal adj.: 70 to 95°

Linearity resolution adj.: 1/300 to 1/1000

Restart limiting timer adj.: 0 to 30 sec.

Isolation: Signals to power to sequential signals to metallic housing

Fuse: 3 A (replaceable)

Manual operation: Available (manual handle stem: approx. 15 turns plus 90°/output stem: 90° action)

User-configurable items:

Configurable with Programming unit (model: PU-2x)

- Full-closed/full-open signal position

- Opening/closing speed
- Restart limiting timer
- Closed/open side limiter
- Resolution

INPUT SIGNAL SPECIFICATIONS

- **DC Current:** Input resistor incorporated (not removable)
- **Forced Operation:** External contact signal input terminals provided for compulsory opening or closing operation
- Rating:** 5 V DC @ 2.5 mA

OUTPUT SIGNAL SPECIFICATIONS

- **Position Signal:** 4 - 20 mA DC
- Load resistance:** $\leq 300 \Omega$
- **Sequential Control Signal:** "Full-open", "full-closed" and "alarm"
- Open collector:** 30 V DC @ 100 mA max.
- Saturation voltage:** 1 V DC

INSTALLATION

- Power consumption:** 180 VA
- Stand-by consumption:** 45 VA
- Operating temperature:** -20 to +55°C (-4 to +131°F)
- Operating humidity:** 30 to 85 %RH (non-condensing)
- Vibration:** Passed test condition below
 - Fixed frequency endurance test
 - Acceleration: 2 G (19.6 m/s²)
 - Frequency: at resonant frequency
 - Endurance: 30 min.
 - Direction: X, Y, Z
 - Sweep endurance test
 - Acceleration: 2 G (19.6 m/s²)
 - Frequency: 10 to 1000 Hz
 - Cycle: 20 cycles
 - Rate: 1 oct./min.
 - Endurance: approx. 4 hr. 30 min.
 - Direction: X, Y, Z
- Mounting position:** All directions
- Prevent water from accumulating around the output stem.
- Weight:** Approx. 26.5 kg (58.42 lb)

PERFORMANCE

- Insulation resistance:** $\geq 100 \text{ M}\Omega$ with 500 V DC (signals to power supply voltage to sequential signals to metallic housing)
- Dielectric strength:**
 - 2000 V AC @ 1 minute
 - signals or metallic housing* to power supply voltage
 - power supply voltage to sequential signals
 - signals or metallic housing* to sequential signals

- 500 V AC @ 1 minute
- signals to metallic housing
- * Short between signals and metallic housing

STANDARDS & APPROVALS

- **EU conformity (CE marking)**
- EMC Directive
 - EMI EN 61000-6-4
 - EMS EN 61000-6-2
- Low Voltage Directive
 - EN 61010-1
 - Installation Category II (300V)
 - Reinforced insulation:
 - Power voltage to I/O signal or seq. signals
 - Power voltage to metallic housing
 - Pollution Degree 2
- RoHS Directive
 - EN IEC 63000

FUNCTIONS

- **Error Detection**

When the position signal is deviated from the input signal but the output stem is stuck due to overload or certain malfunction, the PRP repeats starting the motor at the maximum torque for several times.

If the stem is still stuck after that, the PRP outputs an alarm signal (LED turned ON) and stops power supply to the motor.

In order to reset the PRP, apply several times 0% and 100% input signals in turn, or turn off and on the power supply.
- **Abnormal Temperature Increase Protection**

When the incorporated temperature sensor detects an abnormal temperature increase in the motor, the alarm LED blinks (repeating 0.5-sec. ON - 0.5-sec. OFF) and the power supply to the final control element motor is stopped until the temperature decreases to an acceptable level. The PRP is designed to resume automatically power supply to the motor. It takes longer to resume normal operation when ambient temperature is higher.
- **Restart Limiting Timer**

This unit is equipped with a timer protecting the motor from overheating. The timer prevents the motor from restarting for a certain interval once the motor has been stopped within deadband.

When the high temperature protection is activated in a high temperature ambient, adjust the timer to a longer interval.
- **Motor Preheat Function**

When this unit detects a temperature lower than 0°C or 32°F (approximate) on the surface of its motor, this unit supplies current to the motor in order to warm up and maintain its surface temperature at 5°C or 41°F

(approximate).

Maintain the power-supply voltage ON when this unit is used in the ambient temperature below 0°C or 32°F.

- **Resolution**

The ratio that the stem of the unit rotates according to input signal.

E.g. Resolution is 1/300 for the specification that input signal is 4 to 20 mA, output stem 90°, direct or reverse action. As the span of input signal is 16 mA (20 - 4 = 16 mA), when input signal is changed by 0.053 mA step (16 mA / 300 = 0.053 mA), the output stem rotates 0.3° (90° / 300 = 0.3°).

(Even for output stem 60° setting, resolution is 1/300 = 0.3°/step)

It is not true that input signal = output signal.

(Not input signal 4.00 mA DC = output signal 4.00 mA DC, there is difference around ±0.012 mA DC.)

EXTERNAL DIMENSIONS unit: mm [inch]

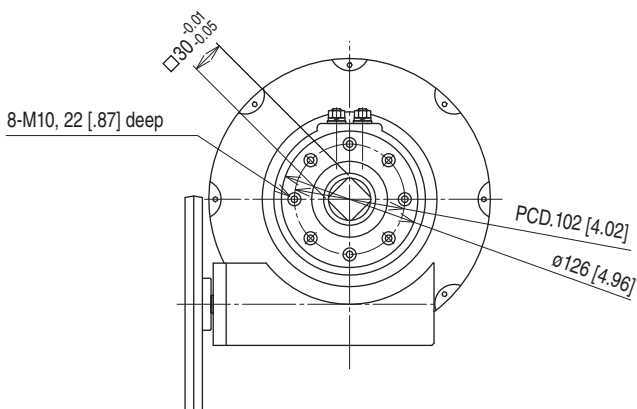
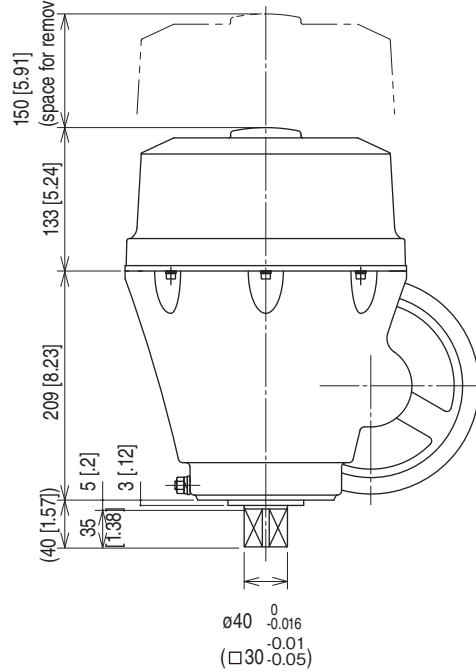
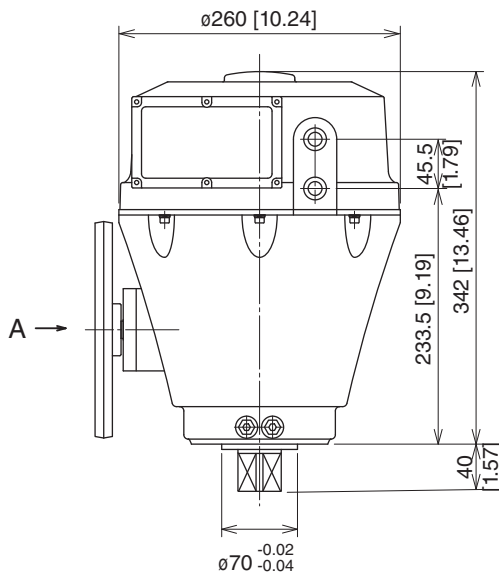
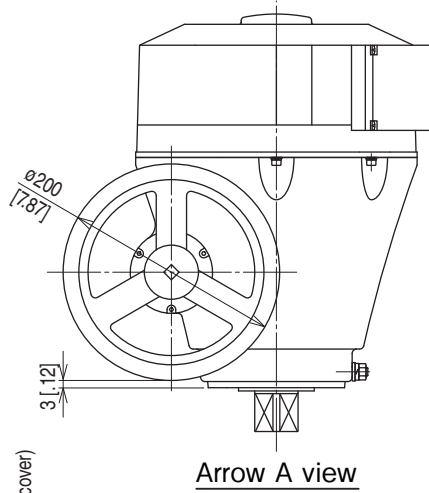
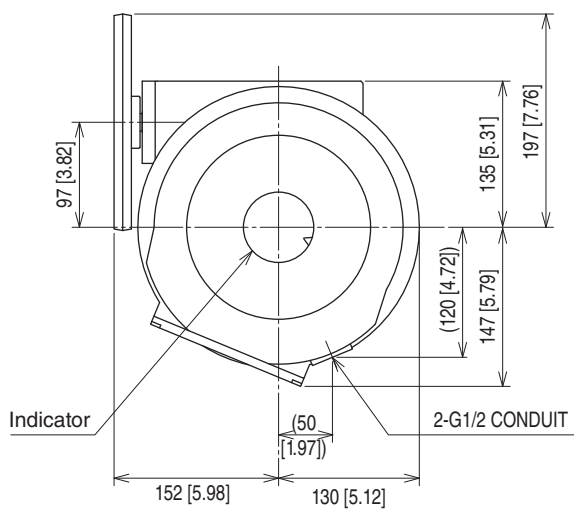

SCHEMATIC CIRCUITRY

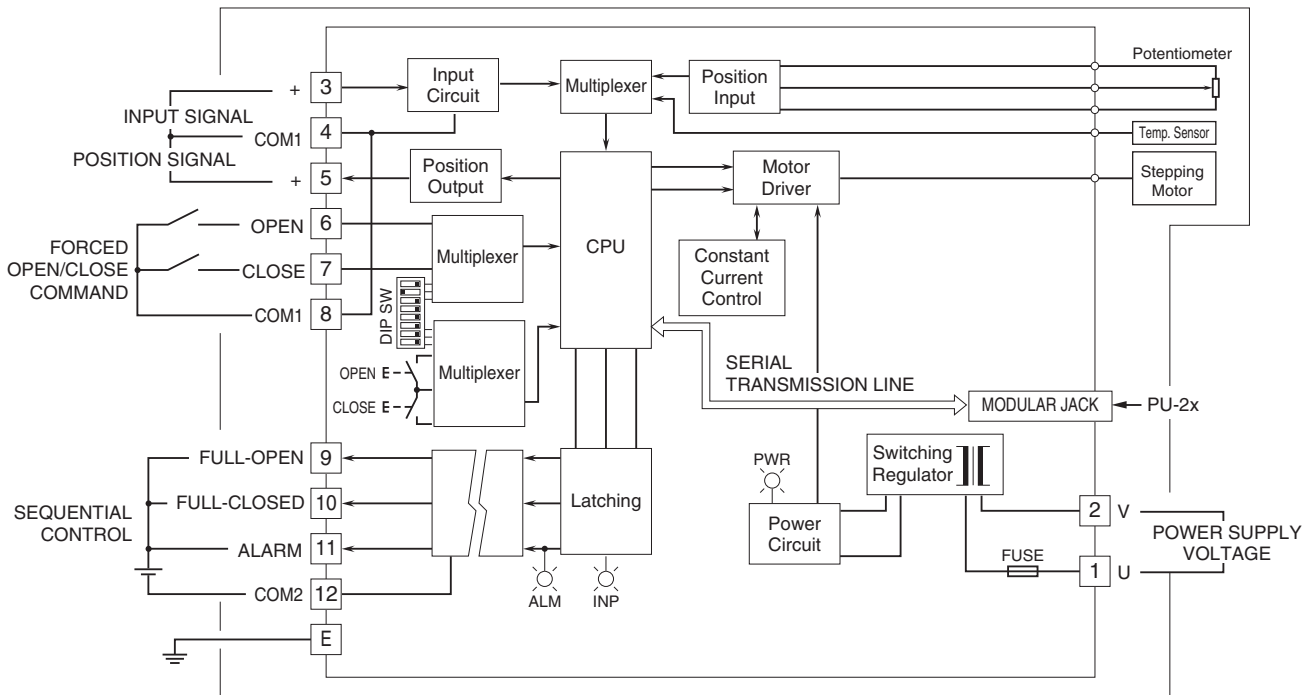

Specifications are subject to change without notice.