

Final Control Elements

SERVO-TOP II ELECTRONIC ACTUATOR

(rotary type; max. torque 200 N·m)

Functions & Features

- Control valve actuator
- User-friendly interface
- High resolution stepping motor
- Failsafe (safety operation) function optional
- Actuator mounting: compliant with ISO 5211 (Table 1, 2 F07) (PRP-1x only)
- Lloyd's Resister approved type available (Environmental categories ENV3)

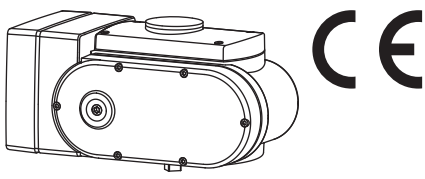

MODEL: PRP-[1][2]-[3][4]

ORDERING INFORMATION

- Code number: PRP-[1][2]-[3][4]

Specify a code from below for each of [1] through [4].
(e.g. PRP-01A-L3/E)

Use Ordering Information Sheet (No. ESU-4823).

Factory setting (table below) will be used if not otherwise specified.

PARAMETER	FACTORY SETTING
Action	Reverse
Operation at input failure	Hold position at input failure
Output stem position at full-closed	0°
Output stem position at full-open	90°
Ex-factory stem position	Without failsafe function: 90° With failsafe function: 0°
Closed side limiter	0%
Open side limiter	100%
Full-closed signal	3.6%
Full-open signal	96.4%
Split range	Without
Split range type	LO
Split point	50%
Opening/closing speed	01: 100 N·m, 12 sec./90° 03: 100 N·m, 24 sec./90° 11: 200 N·m, 16 sec./90° 13: 200 N·m, 24 sec./90°
Deadband	0.5%
Restart limiting timer	2 sec.
Failsafe opening/closing speed*	01: 100 N·m, 12 sec./90° 03: 100 N·m, 24 sec./90° 11: 200 N·m, 16 sec./90° 13: 200 N·m, 24 sec./90°
Failsafe target position*	0°
Resolution	1/200

*Option/E

[1] TORQUE, OPERATION TIME

01: 100 N·m, 12 sec./90°

03: 100 N·m, 24 sec./90°

00: Refer to the torque explanation on the manual.
Use specified operation time.

11: 200 N·m, 16 sec./90°

13: 200 N·m, 24 sec./90°

10: Refer to the torque explanation on the manual.
Use specified operation time.

[2] INPUT

Current

A: 4 - 20 mA DC (Input resistance 250 Ω)

Voltage

6: 1 - 5 V DC (Input resistance 1 MΩ min.)

[3] POWER INPUT

AC Power

K3: 100 - 120 V AC

(Operational voltage range 90 - 132 V, 47 - 66 Hz)
(Not selectable for CE)

L3: 200 - 240 V AC

(Operational voltage range 180 - 264 V, 47 - 66 Hz)

[4] OPTIONS

Failsafe Function (emergency use)

blank: Without

/E: With

RELATED PRODUCTS (Products sold separately)

- Programming Unit (model: PU-2x)
- Backup battery (model: PSN-BAT)

GENERAL SPECIFICATIONS

Degree of protection: IP66

Action: Reverse or direct (In "reverse" action, the output stem turns counterclockwise (seen from the indicator) with an input signal increase.)

Field selectable with DIP switches

Operation at input failure: Stem stop at full-open, full-close or hold position at input failure; field selectable with DIP switches

Minimum input signal

Current input: ≥ 2.0 mA DC

Voltage input: ≥ 0.5 V DC

Wiring conduits: G 1/2 female thread (two)

Terminal block: 7.62 mm pitch; M3 screw terminals (torque 0.8 N·m)

Housing material: Diecast aluminum

Coating: Baked acrylic resin

Drive: Stepping motor
Insulation class: E
Power control element: Power MOS-FET
Position detection: Potentiometer
Full-open and full-closed positions: -5 to +95°; minimum span 45°; field adjustable with control buttons
Full-closed signal adj.: 0 - 25 %
Full-open signal adj.: 75 - 100 %
Close side limiter adjustment: -5 - +25 %
Open side limiter adjustment: 75 - 105 %
Deadband adjustment: 0.1 - 5.0 % (Deadband width affects the resolution. See Resolution in Performance section.)
Restart limiting timer adjustment: 0 - 30 sec.
Opening/closing speed adjustment
 • PRP-0: 8.5 to 125 sec./90°
 • PRP-1: 16 to 125 sec./90°
Isolation: Signals to power to sequential signals to battery status (Option /E) to metallic housing
Fuse: 3 A (replaceable)
Protective functions: Error detection, abnormal temperature increase protection, motor preheat
Power indicator: Green LED turns on with power supplied.
Input indicator: Green LED turns on with normal input
Alarm indicator: Red LED turns on in error; blinks in 1-sec. intervals when abnormal temperature increase is detected.
Manual operation: Available (10 turns/90°)
User-configurable items:
 Configurable with Programming unit (model: PU-2x)
 • Output stem position at full-closed/open
 • Opening/closing speed
 • Closed/open side limiter
 • Full-closed/open signal
 • Split range and point
 • Deadband
 • Restart limiting timer
 • Failsafe opening/closing speed (option /E)
 • Failsafe target position (option /E)
■ BATTERY (failsafe function option)
Battery chemistry: Nickel-cadmium
Battery life: Rechargeable up to 500 times; or 3 years, whichever is shorter, depending upon conditions of use
Drive capacity: Once
Charge method: Trickle charge after full rapid charge
Charge time: 180 minutes (completely discharged)
Power indicator: Red LED turns ON with the power supplied
Battery status indicator: Red LED turns ON with full charge; OFF with the power removed.
Charge indicator: Red LED turns ON during rapid charge

provided for compulsory opening or closing operation
Rating: 5 V DC @ 2.5 mA
■ Split Range: Specify split range type and split point.
Split range type: LO or HI
Split point: 30 - 70 %

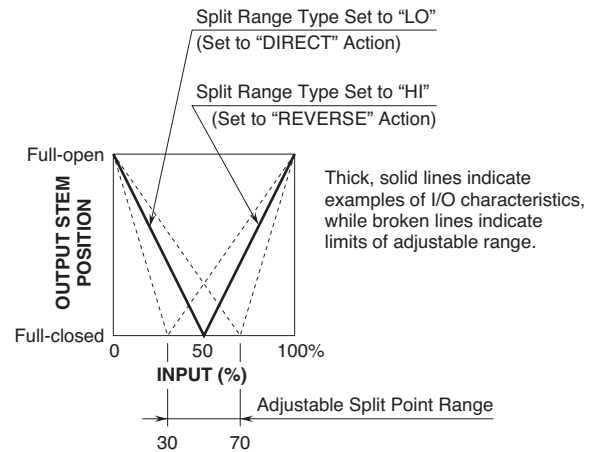

OUTPUT SPECIFICATIONS

■ Position Signal: 4 - 20 mA DC
Load resistance: ≤ 300 Ω
 • **Sequential Control Signal:** "Full-open", "full-closed" and "alarm"
Open collector: 30 V DC @ 100 mA max.
Saturation voltage: 1 V DC
■ Failsafe Function (optional)
Battery status output: Outputs a signal in synchronization with the battery status indicator; ON with full charge and OFF with the power removed.
Open collector: 30 V DC @ 100 mA
Saturation voltage: 1 V DC
 • **Speed & torque**

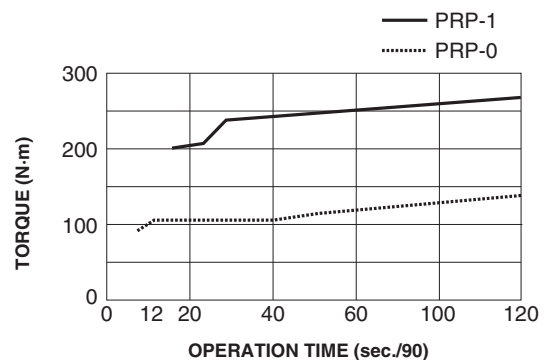

Note: Operational torque for PRP-0 is 100 N-m.
 Operational torque for PRP-1 is 200 N-m.

INPUT SPECIFICATIONS

■ DC Current: Resistor (2 W) incorporated
■ Forced Operation: External contact signal input terminals

INSTALLATION

Power consumption: Approx. 180 VA

Stand-by consumption: Approx. 18 VA

Operating temperature: -20 to +55°C (-4 to +131°F)

Charge: 0 to 55°C (32 to 131°F)

When the ambient temperature is less than 0°C (32°F), the battery is not charged.

However, the ambient temperature reaches within 0 to 55°C (32 to 131°F), the battery is automatically charged.

Operating humidity: 30 to 85 %RH (non-condensing)

Vibration: Passed test condition below

• **Fixed frequency endurance test**

Acceleration: 2 G (19.6 m/s²)

Frequency: at resonant frequency

Endurance: 30 min.

Direction: X, Y, Z

• **Sweep endurance test**

Acceleration: 2 G (19.6 m/s²)

Frequency: 10 to 1000 Hz

Cycle: 20 cycles

Rate: 1 Oct./min.

Endurance: approx. 4 hr. 30 min.

Direction: X, Y, Z

Mounting position: All directions

Do not mount the actuator with its output stem on the upside if the actuator is to be exposed to dripping water and rain.

Weight: Approx. 10.8 kg (23.8 lb)

Approx. 12.1 kg (26.7 lb) with Option /E

PERFORMANCE

Resolution: 1/200 with 0.5 % deadband (factory setting);
1/1000 with 0.1 % deadband

Insulation resistance: ≥ 100 MΩ with 500 V DC (signal to power to sequential signals to battery status (Option /E) to metallic housing)

Dielectric strength: 2000 V AC @ 1 minute
(signal or metallic housing to power to battery status (Option /E) to sequential signals)

500 V AC @ 1 minute (signal to metallic housing)

STANDARDS & APPROVALS

■ **EU conformity (CE marking)**

• EMC Directive

EMI EN 61000-6-4

EMS EN 61000-6-2

• Low Voltage Directive

• EN 61010-1

• Installation Category II (300V)

• Reinforced insulation:

Power voltage to signal or seq. signals

Power voltage to battery status (with failsafe function only)

Power voltage to metallic housing

• Pollution Degree 2

• RoHS Directive

EN IEC 63000

FUNCTIONS

• **Error Detection**

When the position signal is deviated from the input signal but the output stem is stuck due to overload or certain malfunction, the PRP repeats starting the motor at the maximum torque for several times.

If the stem is still stuck after that, the PRP outputs an alarm signal (LED turned ON) and stops power supply to the motor.

In order to reset the PRP, apply several times 0% and 100% input signals in turn, or turn off and on the power supply.

• **Abnormal Temperature Increase Protection**

When the incorporated temperature sensor detects an abnormal temperature increase in the motor, the alarm LED blinks (repeating 0.5-sec. ON - 0.5-sec. OFF) and the power supply to the final control element motor is stopped until the temperature decreases to an acceptable level. The PRP is designed to resume automatically power supply to the motor. It takes longer to resume normal operation when ambient temperature is higher.

• **Restart Limiting Timer**

This unit is equipped with a timer protecting the motor from overheating. The timer prevents the motor from restarting for a certain interval once the motor has been stopped within deadband.

When the high temperature protection is activated in a high temperature ambient, adjust the timer to a longer interval.

• **Motor Preheating Function**

When the internal temperature sensor detects a temperature lower than 0°C / 32°F (approximate) on the surface of the motor, the unit supplies current to the motor to warm up the motor to 0°C / 32°F.

Maintain the power supply ON when this unit is used in the ambient temperature below 0°C or 32°F.

• **Resolution**

The ratio that the stem of the unit rotates according to input signal.

E.g. Resolution is 1/200 for the specification that input signal is 4 to 20 mA, output stem 90°, direct or reverse action. As the span of input signal is 16 mA (20 - 4 = 16 mA), when input signal is changed by 0.08 mA step (16 mA / 200 = 0.08 mA), the output stem rotates 0.45° (90° / 200 = 0.45°).

(Even for output stem 45° setting, resolution is 1/200 =

0.45°step)

It is not true that input signal = output signal.

(Not input signal 4.00 mA DC = output signal 4.00 mA DC,
there is difference around 0.04 mA DC.)

REFERENCE DATA

Below data is based on the test results and serves as a reference only. Actual values may differ depending on the unit.

- Fixed frequency endurance test

Acceleration: 5.1 G (50 m/s²)

Frequency: at resonant frequency

Amplitude (Maximum displacement): 0.35 mm

Endurance: 30 min.

Direction: X, Y, Z

- Sweep endurance test according to IEC 61298-3

Acceleration: 6 G (58.8 m/s²)

Frequency: 10 to 1000 Hz

Amplitude (Maximum displacement): 0.15 mm

Cycle: 20 cycles

Rate: 1 Oct./min.

Endurance: approx. 4 hr. 30 min.

Direction: X, Y, Z

EXTERNAL DIMENSIONS unit: mm [inch]

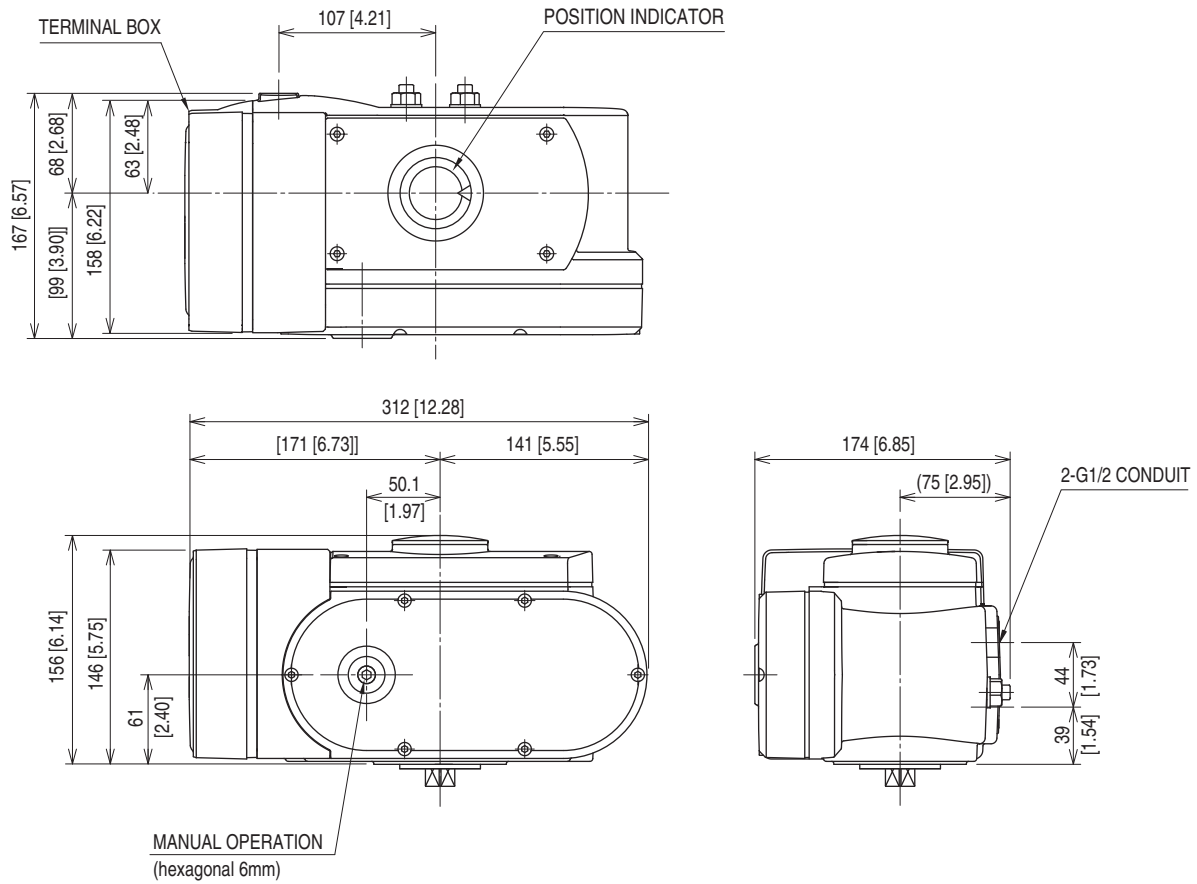

OUTPUT STEM DETAIL

• PRP-0

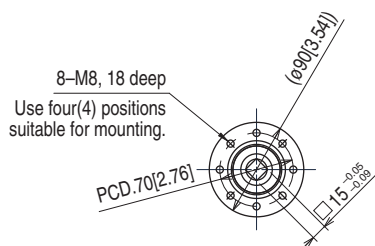
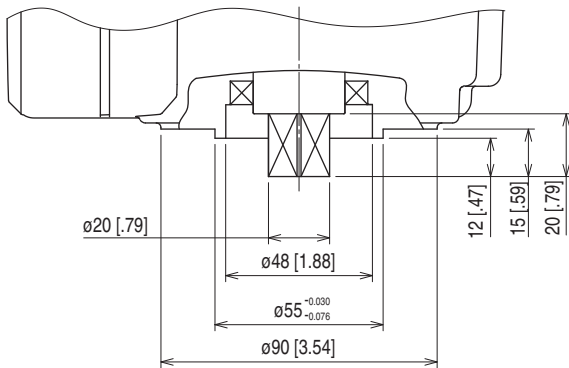

• PRP-1 [Compliant with ISO 5211 Table 1, 2 F07]

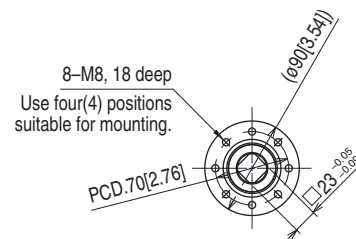
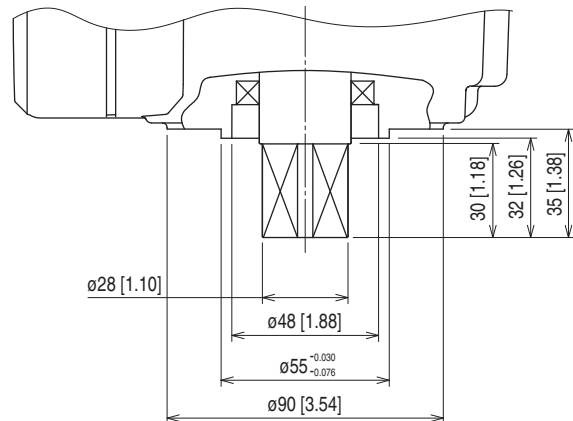

■ OPTION /E, FAILSAFE FUNCTION

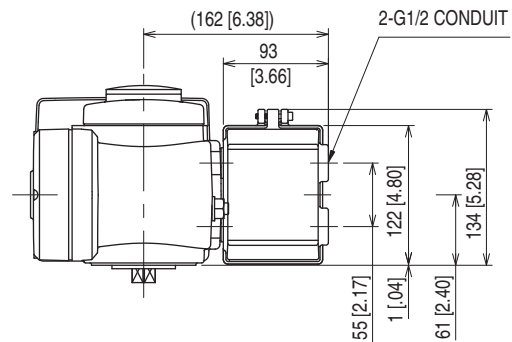
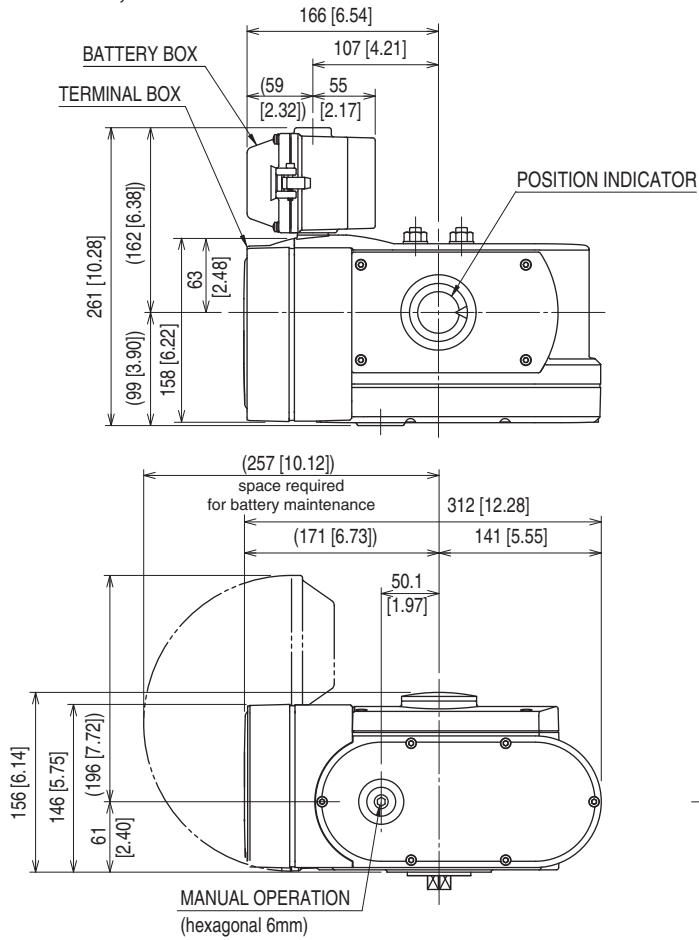

■ OUTPUT STEM DETAIL

• PRP-0

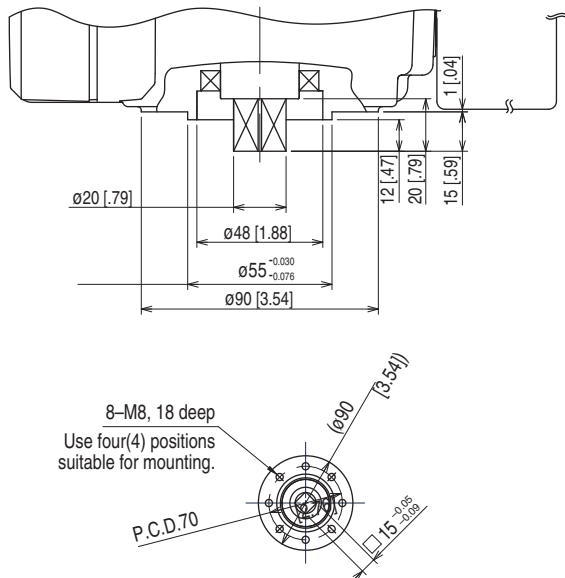

• PRP-1 [Compliant with ISO 5211 Table 1, 2 F07]

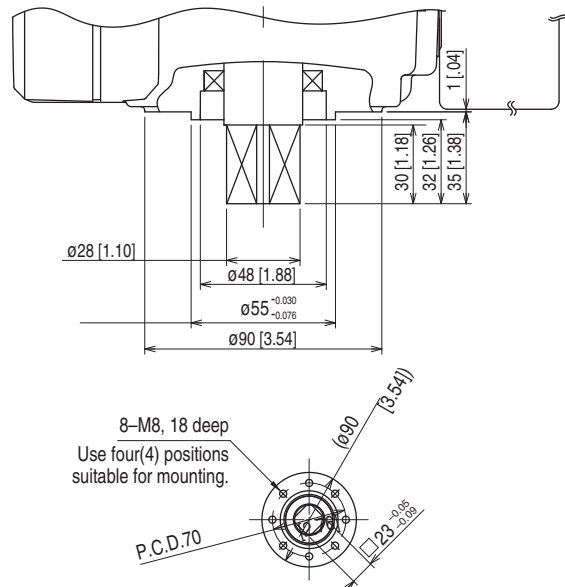

SCHEMATIC CIRCUITRY

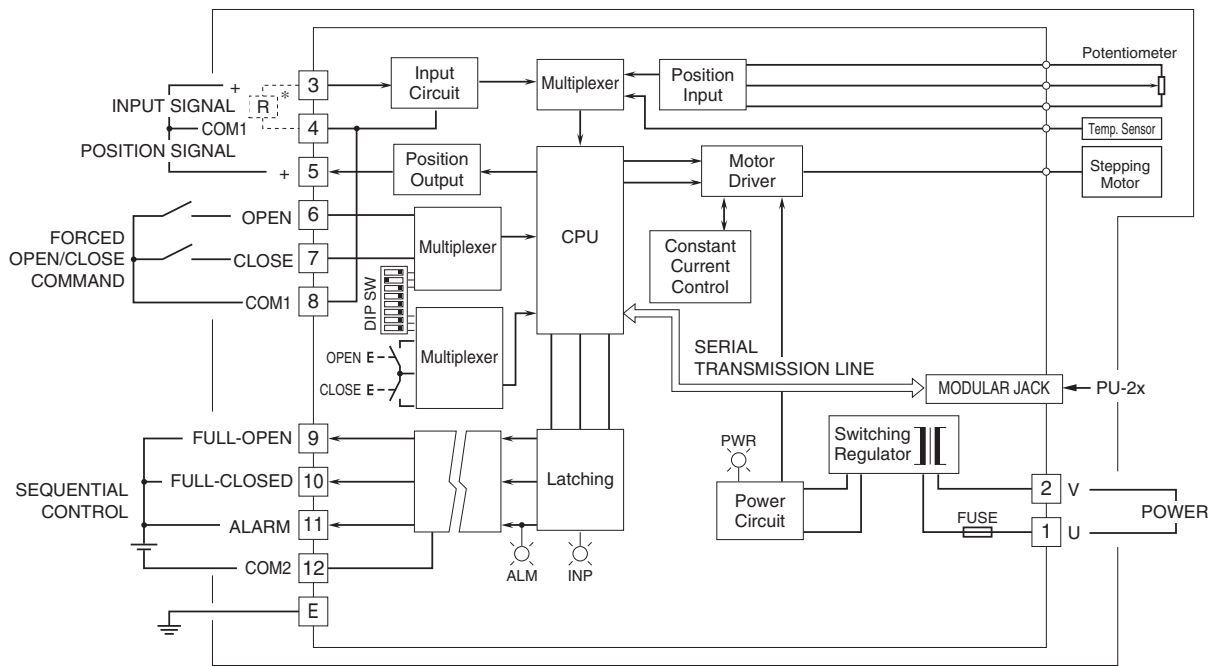

*Input resistor attached for a current input.

■ OPTION /E, FAILSAFE FUNCTION

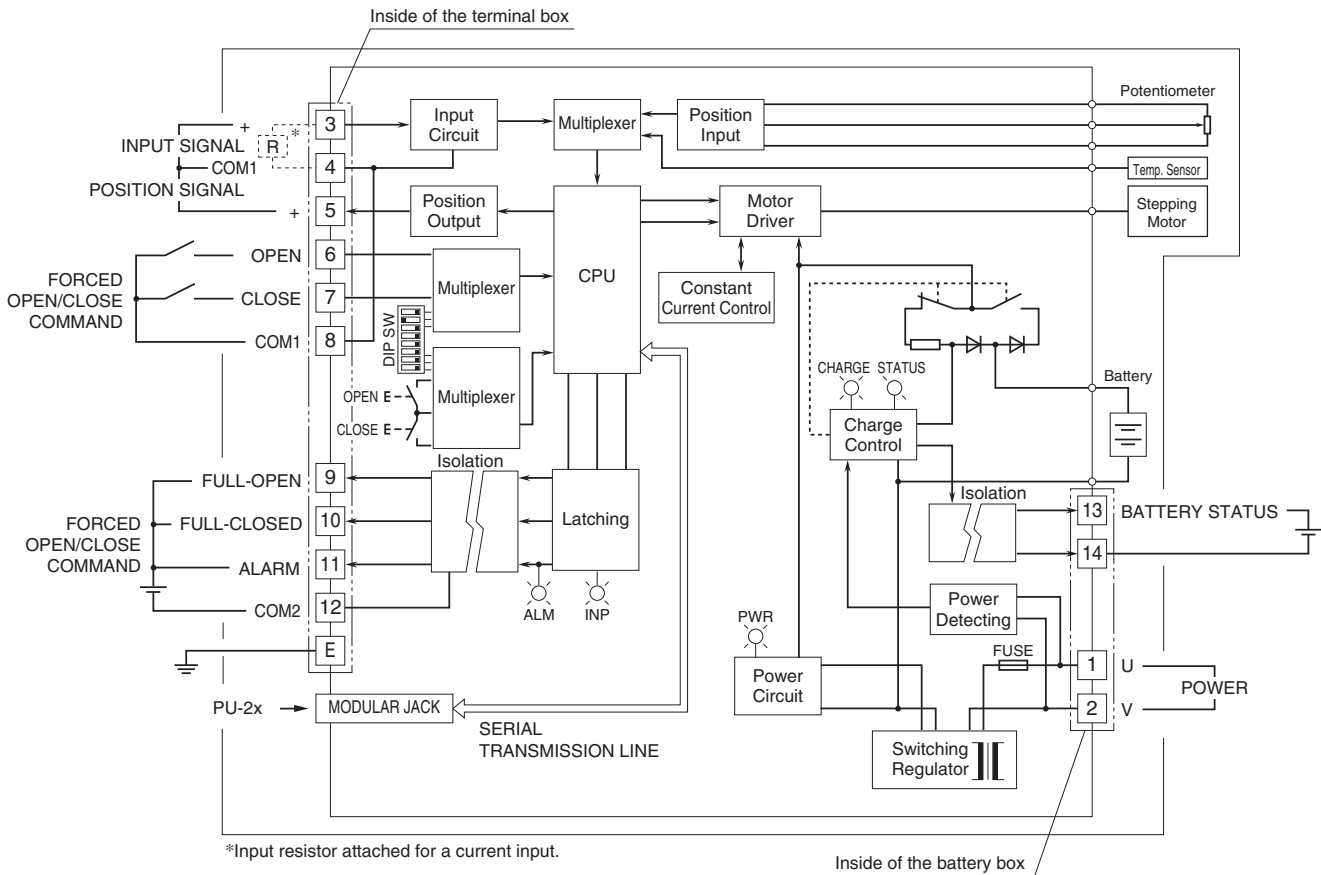

*Input resistor attached for a current input.

Inside of the battery box



Specifications are subject to change without notice.