

Lightning Surge Protectors for Electronics Equipment M-RESTER

LIGHTNING SURGE PROTECTOR FOR CC-Link

Functions & Features

- For CC-Link communication
- Designed specifically for the network
- Available with CC-Link Ver.1.10/2.00
- DIN rail mounting

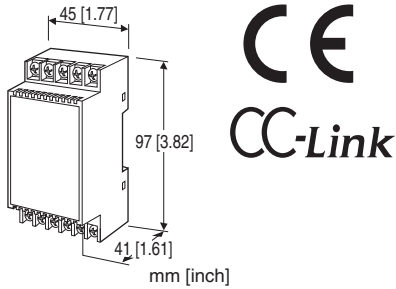

MODEL: MDW5-CC

ORDERING INFORMATION

- Code number: MDW5-CC

APPLICABLE NETWORK

CC-Link Ver.1.10/2.00

GENERAL SPECIFICATIONS

Construction: Terminal block

Connection

Surge side: M3.5 screw terminals (torque 0.8 N·m)

Protected device side: M3 screw terminals (torque 0.8 N·m)

Screw terminal: Nickel-plated steel

Housing material: Flame-resistant resin (black)

INSTALLATION

Operating temperature: -5 to +55°C (23 to 131°F)

Operating humidity: 30 to 90 %RH (non-condensing)

Mounting: DIN rail

Weight: 100 g (0.22 lb)

PERFORMANCE

Max. continuous operating voltage (Uc):

Line to line (DA - DB): ±5 V

Line to earth (DA or DB - DG): ±5 V

Line to shield or earth (DG - SLD or FG): ±50 V

Voltage protection level (Up):

@ 4 kV (1.2/50 μsec.)

Line to line (DA-DB): ±20 V

Line to earth (DA or DB to DG): +20 V, -10 V

Line to shield or earth (DG - SLD or FG): ±300 V

Response time:

Line to line (DA-DB): ≤ 4 nsec.

Line to line (DA or DB - DG): ≤ 4 nsec.

Line or shield to earth (DG - SLD or FG): ≤ 20 nsec.

Leakage current (@ max. continuous operating voltage)

Line to line (DA - DB): 0.2 mA

Line to line (DA or DB to DG): 0.2 mA

Line to shield or earth (DG to SLD or FG): 1 mA

Maximum discharge current: 10 kA (8/20 μsec.)

Max. load current: 100 mA

Internal series resistance: Approx. 2 Ω (per wire)

Capacitance @ 1 MHz:

Line to line (DA to DB): approx. 30 pF

Line to Line (DA or DB to DG): approx. 60 pF

Line to earth (DG to SLD or FG): approx. 1000 pF

Surge protection: IEC 61643-21 Categories C1, C2, D1

STANDARDS & APPROVALS

EU conformity:

EMC Directive

EMS EN 61000-6-2

RoHS Directive

CONNECTION EXAMPLES

■ NETWORK CONFIGURATION

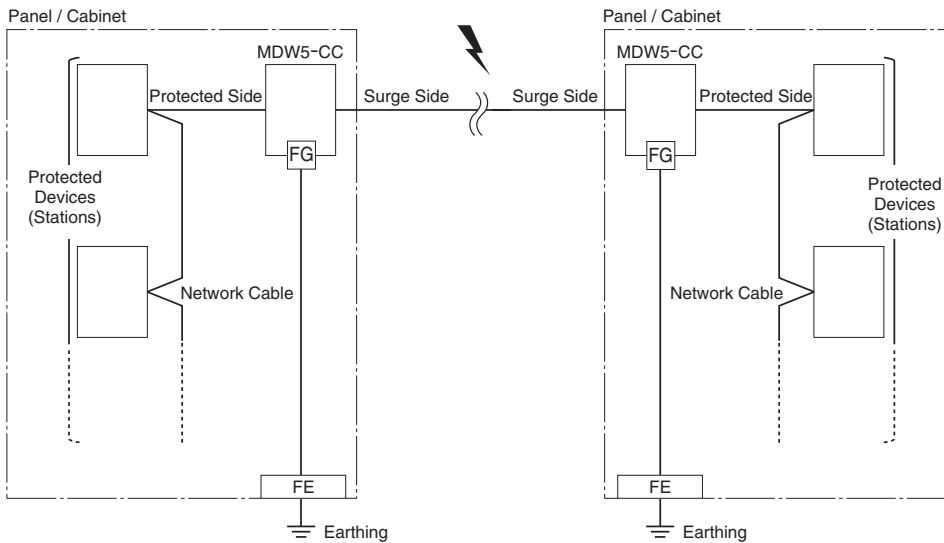

- Install the lightning surge protector in a place where it is considered lightning surge may enter (where the space between panels/cabinets are greatly separated, such as outdoor wiring).
- About total transmission speed, install 2 surge protectors as maximum per 1 network to use the maximum transmission distance.*1 Also, connecting the surge protector, serial resistance or the number of CC-Link devices capacitance, are added to the network, therefore, it is needed to reduce the maximum number of slave stations per number of surge protector's connections. Reduce until 5 the number of slave station connections per 1 surge protector. If you install 2 surge protectors, the maximum number of connections is 54.
- To keep good communication quality, leave a distance of at least 20 cm between units, and as short as possible length for the cable of the surge protector and protected devices.
- Irrespectively of transmission speed, T junction connection is not available.
- Make the wiring in concordance with Ver.1.1.0 specifications.
- Refer to "Cable Wiring Manual" issued by CC-Link Partner Association for CC-Link network details.

■ NETWORK WITH BRANCH

- When lightning surge may enter from cables more than one, use the repeater (T-Branch) units and make T-Branch network so that additional surge protectors can be installed.
- The maximum number of surge protectors for each branch is two (2).*1
- When 2 surge protectors are used on each of both trunk and branch networks (see below), 54 CC-Link devices can be installed on the each networks.
- In case of using repeater (T-Branch) unit, refer to "Cable Wiring Manual" issued by CC-Link Partner Association and manual of the unit.

*1. if the CC-Link devices used capacitance is low or transmission distance is short, there are cases that it is due to the slave stations are less than the number of the maximum connections, or to the arrester extension. In such a case, check all connection installation.

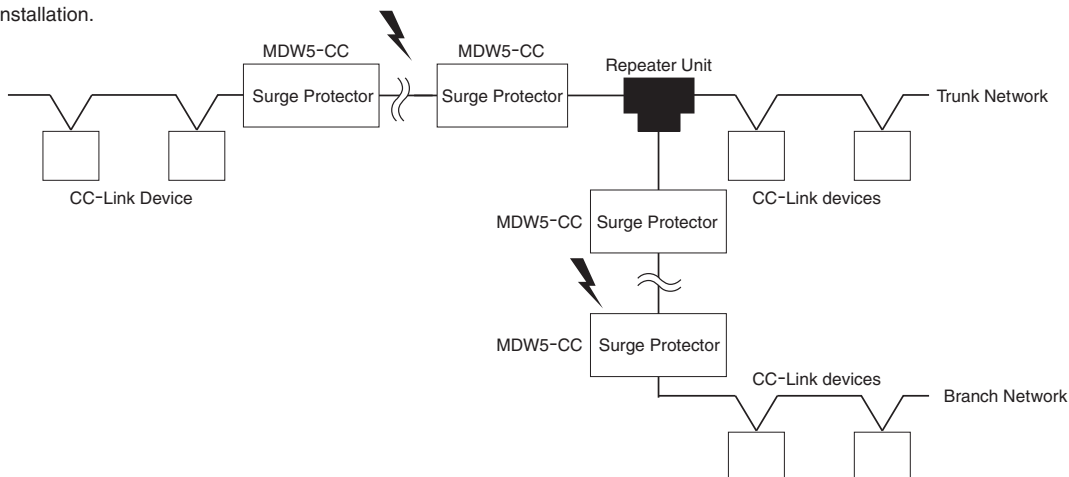

EXTERNAL DIMENSIONS & TERMINAL ASSIGNMENTS unit: mm [inch]

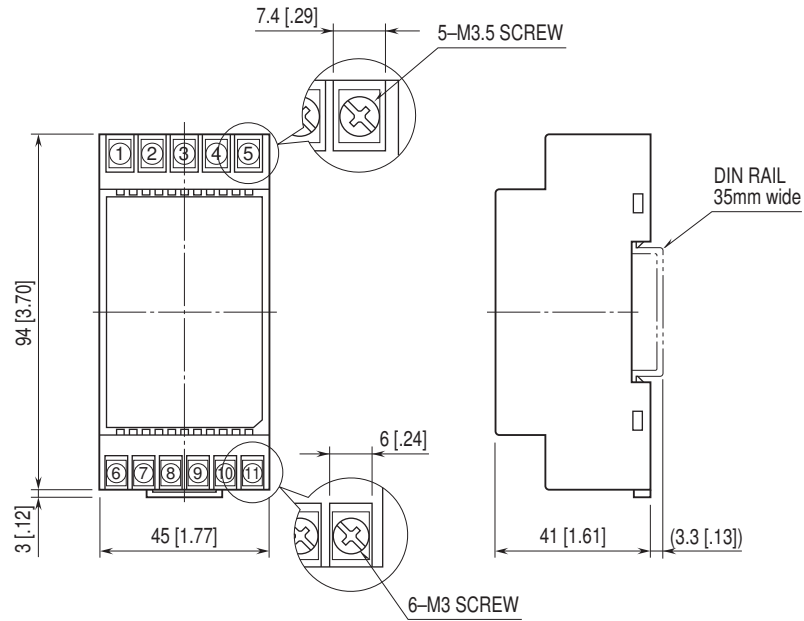

• When mounting, no extra space is needed between units.

SCHEMATIC CIRCUITRY

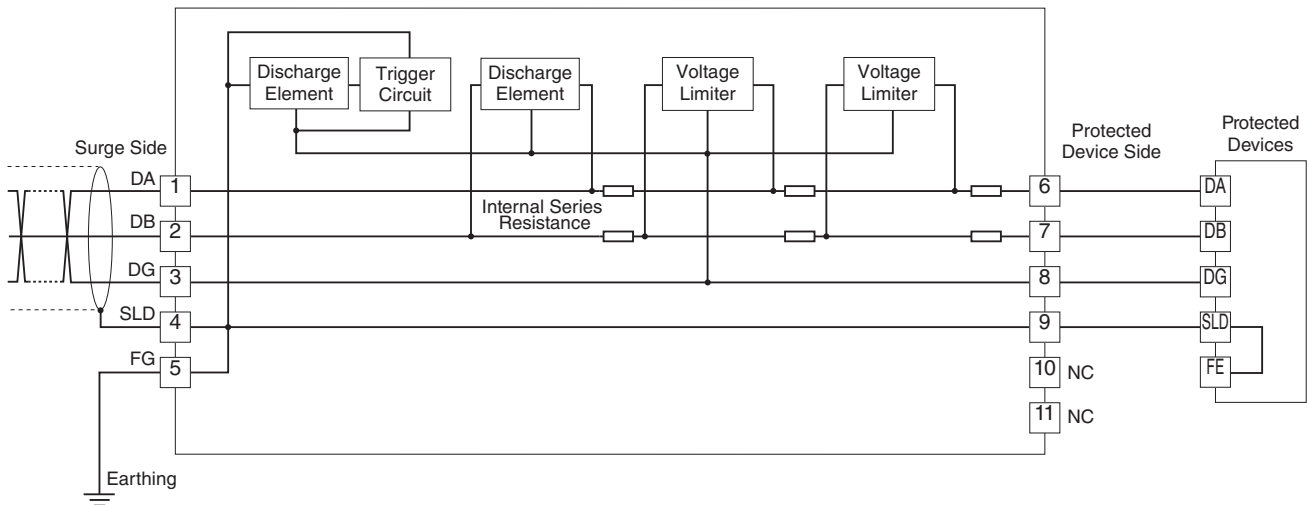

Specifications are subject to change without notice.