

## Lightning Surge Protectors for Electronics Equipment M-RESTER

### LIGHTNING SURGE PROTECTOR FOR RTD USE

#### Functions & Features

- Designed specifically for resistance temperature detector (RTD) circuits
- Protecting RTD and RTD transmitters from damage caused by surges on the RTD wiring
- Absorbs surges only without affecting instrumentation signal
- No interruption of signal by unplugging the protector element

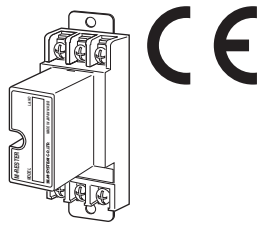

### MODEL: MDP-RB[1]

#### ORDERING INFORMATION

- Code number: MDP-RB[1]  
Specify a code from below for [1].  
(e.g. MDP-RB/A33/Q)
- Specify the specification for option code /Q  
(e.g. /C01)

#### [1] OPTIONS (multiple selections)

##### DIN Rail Mounting Adapter

blank: Without

/A33: With adapter (model A-33)

##### Other Options

blank: none

/Q: Option other than the above (specify the specification)

#### SPECIFICATIONS OF OPTION: Q

**COATING (For the detail, refer to M-System's web site.)**

/C01: Silicone coating

/C02: Polyurethane coating

/C03: Rubber coating

#### GENERAL SPECIFICATIONS

**Construction:** Plug-in

**Connection:** M4 screw terminals (torque 0.8 N·m)

**Screw terminal:** Nickel-plated steel

**Housing material:** Flame-resistant resin (black)

#### INSTALLATION

**Operating temperature:** -5 to +55°C (23 to 131°F)

**Operating humidity:** 30 to 90 %RH (non-condensing)

**Mounting:** Surface or DIN rail

**Weight:** 140 g (0.31 lb), standard

165 g (0.36 lb), with DIN rail mounting adapter

#### PERFORMANCE

**Max. continuous operating voltage (Uc):**

B to C: ±6 V

B or C to A: ±3 V

Line to earth: ±140 V

**Voltage protection level (Up):**

• @ 1 kV (100 A)

2 to 3: ±32 V

2 or 3 to 1: ±16 V

Line to earth: ±650 V

• @ 2 kV (1 kA)

2 to 3: ±40 V

2 or 3 to 1: ±25 V

Line to earth: ±800 V

**Response time:** ≤ 0.1 μsec.

**Leakage current:**

B to C: ≤ 2 μA @ ±6 V DC

B or C to A: ≤ 2 μA @ ±3 V DC

Line to earth: ≤ 2 μA @ ±140 V DC

**Max. discharge current (Imax):** 5000 A (8 / 20 μs)

**Nominal current (In):** 100 mA

**Internal series resistance:** 10 Ω ±0.1 %, 30 ppm/°C (17 ppm/°F)

**Capacitance @ 1 MHz:**

Line to line: ≤ 1000 pF

Line to earth: ≤ 100 pF

**Surge protection:** IEC 61643-21 Categories C1, C2, D1

#### STANDARDS & APPROVALS

**EU conformity:**

EMC Directive

EMI EN 61000-6-4

EMS EN 61000-6-2

RoHS Directive

## CONNECTION EXAMPLES

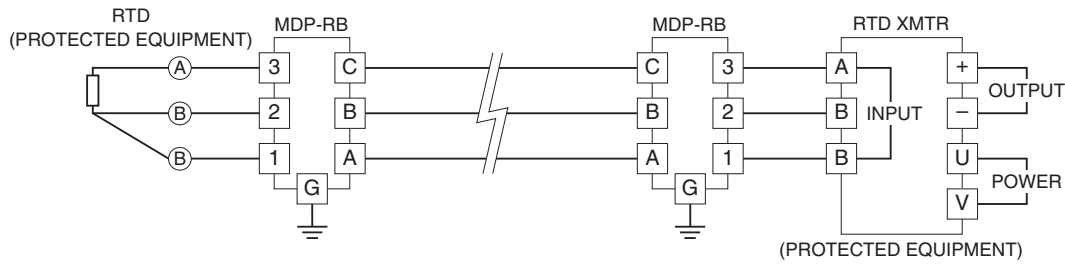

## GROUNDING

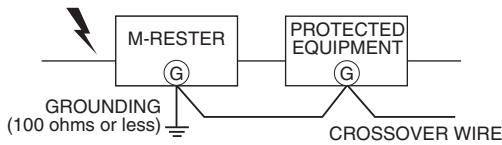

A crossover wire between M-RESTER ground and the ground or metallic housing of the equipment is required for protection. If the protected equipment has no ground terminal, ground the M-RESTER only. When the M-RESTER is mounted with DIN Rail Mounting Adapter, connect the grounding wire to the mounting screw of the M-RESTER.

## EXTERNAL DIMENSIONS & TERMINAL ASSIGNMENTS unit: mm [inch]

### ■ STANDARD

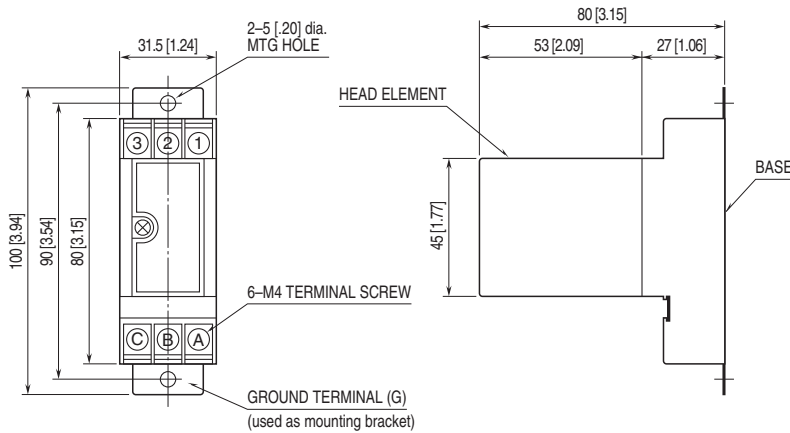

### ■ WITH DIN RAIL MOUNTING ADAPTER

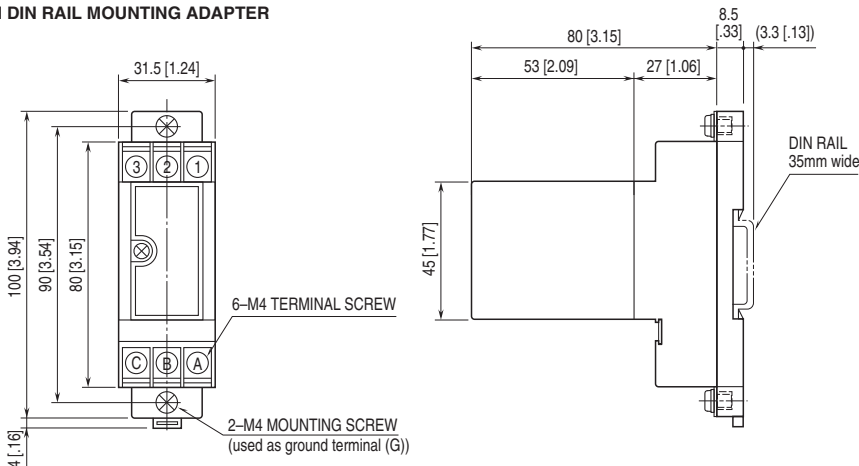

**MOUNTING REQUIREMENTS unit: mm [inch]**

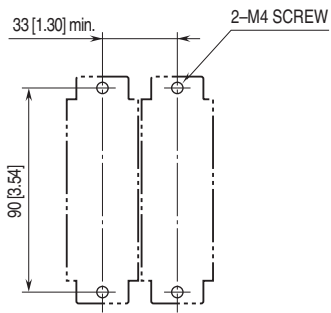

**SCHEMATIC CIRCUITRY & CONNECTION DIAGRAM**

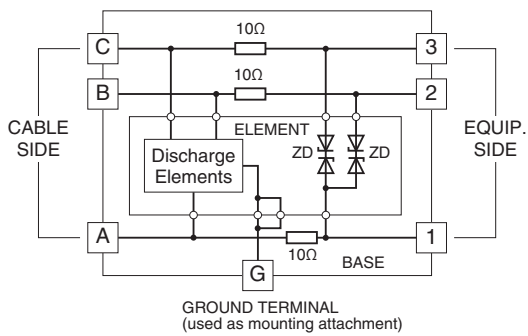

Specifications are subject to change without notice.