

Lightning Surge Protectors for Electronics Equipment M-RESTER

LIGHTNING SURGE PROTECTOR FOR STRAIN GAUGE

(ultra-slim)

Functions & Features

- High discharge current capacity 20 kA (8 / 20 μ s), 1 kA (10 / 350 μ s)
- Ultra-thin 7-mm-wide module can be mounted in high density
- Excellent protection employing multi-stage SPD circuits
- DIN rail mounting and grounding
- Shield terminal provided
- Protects strain gauges and transmitters

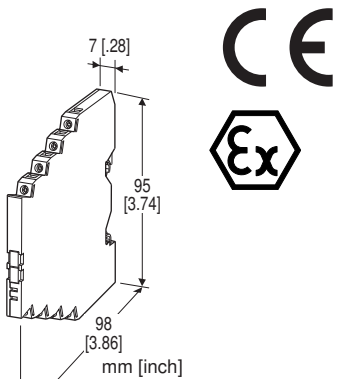

MODEL: MD7LC-[1][2][3]

ORDERING INFORMATION

- Code number: MD7LC-[1][2][3]

Specify a code from below for each of [1] through [3].
(e.g. MD7LC-10/Q)

For the safety approval code 2, specify the product's destination country using Ordering Information Sheet (No. ESU-8057).

- Specify the specification for option code /Q
(e.g. /C01)

[1] SERIES RESISTANCE

0: Without (No CE marking; ATEX approval not available)

1: With

[2] SAFETY APPROVAL

0: None

2: ATEX intrinsic safety

[3] OPTIONS

blank: none

/Q: With options (specify the specification)
(ATEX intrinsic safety not available)

SPECIFICATIONS OF OPTION: Q

COATING (For the detail, refer to M-System's web site.)

/C01: Silicone coating

/C02: Polyurethane coating

RELATED PRODUCTS

- Terminal block for grounding (model: MD7G)

GENERAL SPECIFICATIONS

Construction: Slim-sized front terminal structure

Degree of protection: IP20

Connection: Euro terminal block (torque 0.3 N·m)

Applicable wire size: 0.2 - 2.5 mm², stripped length 8 mm

Grounding: DIN Rail

Housing material: Flame-resistant resin (black)

INSTALLATION

Operating temperature: -25 to +85°C (-13 to +185°F)

(See Safety Parameters for use in a hazardous location.)

Operating humidity: 30 to 90 %RH (non-condensing)

Mounting: DIN Rail (TH35-7.5, 1-mm-thick)

Oxide film on the surface of an aluminium DIN rail may lower the electric conductivity between this module and the ground. Use a steel or copper rail.

Weight: 70 g (2.5 oz)

PERFORMANCE

MODEL NO.		MD7LC-0	MD7LC-1
Max. continuous operating voltage (Uc)	Output voltage	±0.2V	
	Excitation	15V	
	Line to Earth*1	±15V	
Voltage protection level (Up)	Output voltage	±15V @0.2kV (1.2 / 50 µs)	±40V @6kV (1.2 / 50 µs)
	Excitation	30V @0.2kV (1.2 / 50 µs)	50V @6kV (1.2 / 50 µs)
	Line to Earth*1	±30V @0.2kV (1.2 / 50 µs)	±50V @6kV (1.2 / 50 µs)
Leakage current @Uc	Output voltage	≤ 0.2µA	
	Excitation	≤ 2µA	
	Line to Earth*1	≤ 2µA	
Response time		≤ 4 nsec.	
Max. discharge current (Imax)		100A (8 / 20 µs)	20kA (8 / 20 µs), 1kA (10 / 350 µs)
Nominal current (In)		----	250mA
Internal series resistance		----	1.5Ω ±10% per line
Surge protection (applicable with series resistance only)		IEC 61643-21 Categories C1, C2, D1	

*1. Measured across the terminal 2 and DIN rail, the terminal 7 and DIN rail.

STANDARDS & APPROVALS

EU conformity:

ATEX Directive

Ex ia EN 60079-11

EMC Directive

EMI EN 61000-6-4

EMS EN 61000-6-2

RoHS Directive

Safety approval:

ATEX: Intrinsic safety

⊕ II 1G, Ex ia IIC; T4 and T5 Ga

EN 60079-0

EN 60079-11

SAFETY PARAMETERS

■ ATEX IS DATA

Ui (Vmax)	16V		
Ii (Imax)	any		
Ci	35 nF		
Li	0 µH		
Pi	Temp. Class	Range	Parameter
		T4	-25 to +40°C
	-25 to +60°C		1.2W
	-25 to +80°C		1.0W
	T5	-25 to +40°C	1.0W

CONNECTION EXAMPLES

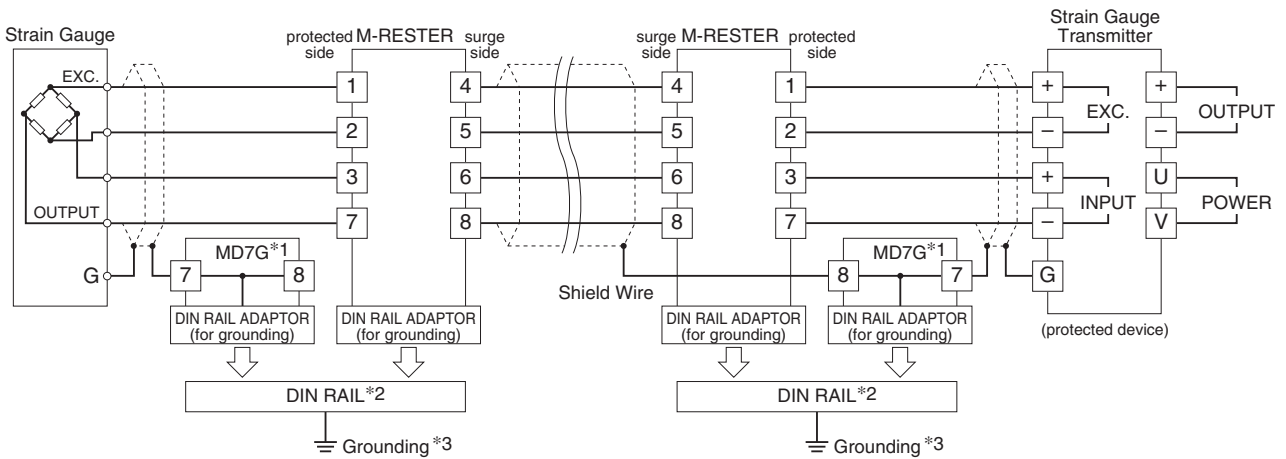

*1. Without the MD7G, cross-wire between the DIN rail and the metal housing of the protected device to equalize the earth potential.

*2. Oxide film on the surface of an aluminium rail may lower the electric conductivity between this module and the ground. Use a steel or copper rail.

*3. Be sure to ground the DIN rail. Recommended grounding resistance $\leq 100\Omega$.

EXTERNAL DIMENSIONS & TERMINAL ASSIGNMENTS unit: mm [inch]

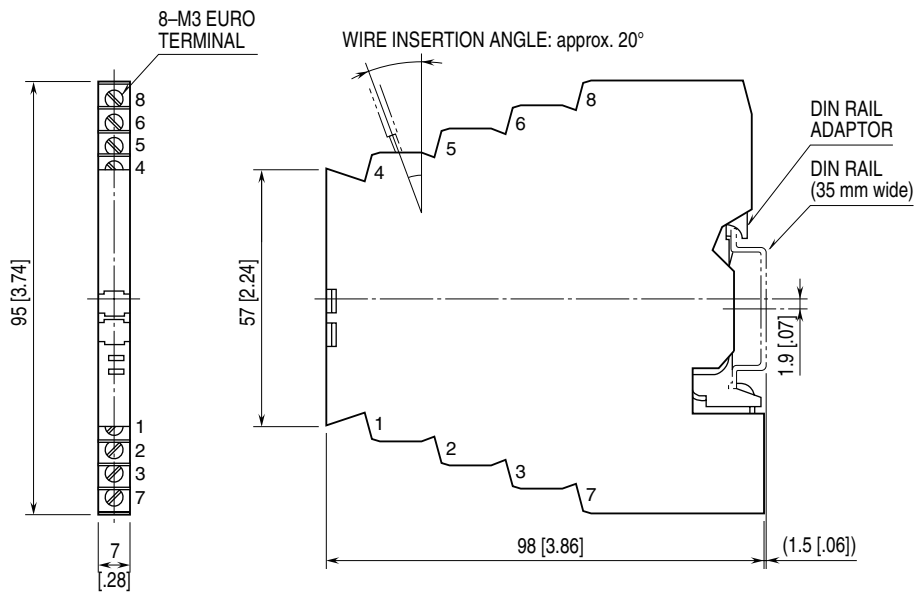

SCHEMATIC CIRCUITRY

■ MD7LC-0

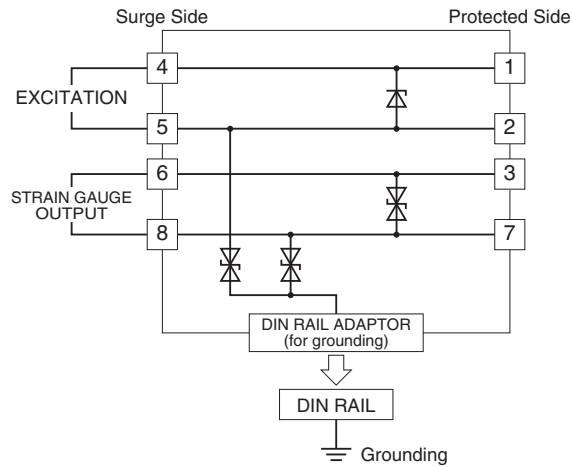

■ MD7LC-1

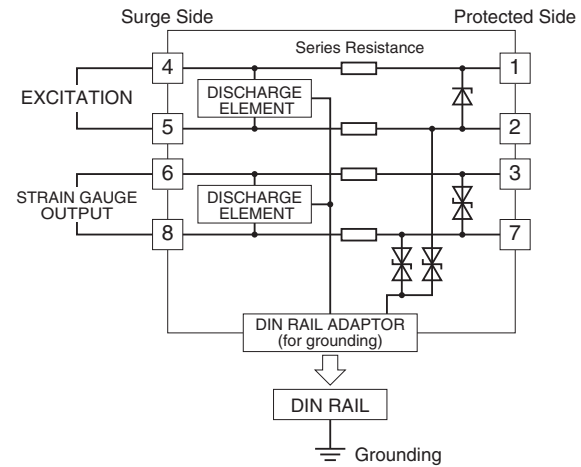

Specifications are subject to change without notice.