

Limit switches

OsiSense XC Special

For hoisting and material handling applications XCR

1

■ XCR

□ With head for rotary movement operators, spring return to off position

1 contact actuation position per direction

562248

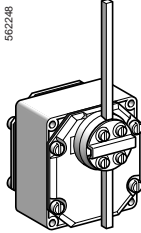

562249

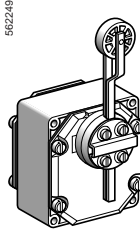

562250

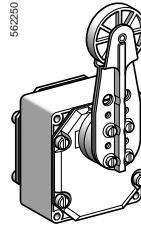

Page 1/178

□ With head for rotary movement operators, stay put

1 contact actuation position per direction

562251

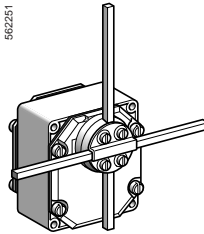

Page 1/178

Limit switches

OsiSense XC Special

For hoisting and material handling applications XCKMR and XCKVR

For conveyor belt shift monitoring applications XCRT

■ XCKMR (metal)

□ With head for rotary movement operators, stay put

4 mechanical actuation positions of 4 contacts
From 2 to 5 electrical positions depending on model

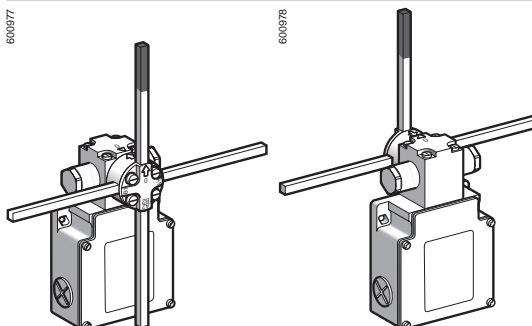

Page 1/196

■ XCKVR (plastic)

□ With head for rotary movement operators, stay put

4 mechanical actuation positions of 4 contacts
From 2 to 5 electrical positions depending on model

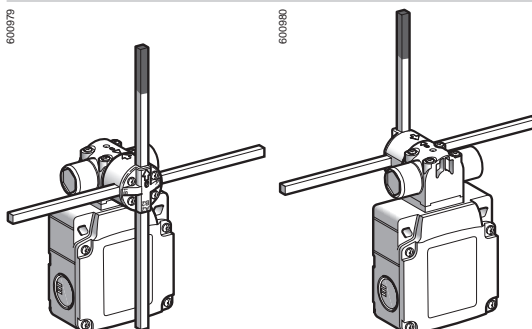

Page 1/196

■ XCRT

□ With head for rotary movement operators, spring return to off position

2 contact actuation positions per direction
1 contact actuated at 10°, other contact at 18°

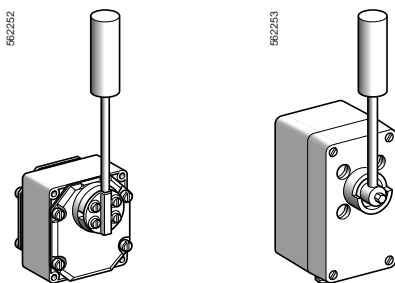

Page 1/192

Limit switches

OsiSense XC Special

For hoisting and material handling applications XCR, XCKMR and XCKVR

For conveyor belt shift monitoring applications XCRT

1

Environment characteristics				
Limit switches		XCR and XCRT	XCKMR (metal)	XCKVR (plastic)
Conformity to standards	Products	EN/IEC 60947-5-1, CSA C22-2 n° 14, CCC	EN/IEC 60947-5-1, CSA C22-2 n° 14, UL 508, CCC	
	Machine assemblies	EN/IEC 60204-1		
Product certifications		XCRA, B, E, F: CE, CSA, CCC, GOST; XCKMR (metal): CE, UL, CSA, CCC, GOST		
Protective treatment	Standard version	"TC"		
Ambient air temperature	For operation	- 25...+ 70 °C	- 25...+ 70 °C	- 25...+ 70 °C
	For storage	- 40...+ 70 °C	- 40...+ 85 °C	- 40...+ 70 °C
Vibration resistance	Conforming to EN/IEC 60068-2-6	9 gn (10...500 Hz)	25 gn (10...500 Hz)	25 gn (10...500 Hz)
Shock resistance	Conforming to EN/IEC 60068-2-27	XCRA, B, E, F: 68 gn, XCRT: 30 gn (18 ms)	50 gn	50 gn
Electric shock protection		Class I conforming to IEC 60536		Class II conforming to IEC 60536
Degree of protection	Conforming to EN/IEC 60529	XCRA, B, E, F: IP 65; XCRT: IP 65	IP 66	IP 65
Degree of protection against mechanical impacts	Conforming to EN 50102	IK 07	IK 07	IK 04
Materials	Enclosure	Metal (except XCRT315: polyester)	Zamak ZP3	(PBT + PC) - GF 30 FR (Valox)
	Cover	Metal (except XCRT315: polyester)	DC03 steel	(PBT + PC) - GF 30 FR (Valox)
	Head	Metal	Zamak ZP3	(PBT + PC) - GF 30 FR (Valox)
Cable entry		1 tapped entry for n°13 cable gland	3 tapped entries for n°13 cable gland or tapped M20 x 1.5	1 tapped entry M20 x 1.5. 2 breakout holes for ISO M20 cable gland

Contact block characteristics				
Rated operational characteristics	Conforming to EN/IEC 60947-5-1 Appendix A	<p>XCRA, B, E, F: ~ AC-15; A300 (Ue = 240 V, Ie = 3 A), Ithe = 10 A ∴ DC-13; Q300 (Ue = 250 V, Ie = 0.27 A)</p> <p>XCRT: ~ AC-15; B300 (Ue = 240 V, Ie = 1.5 A/ Ue = 120 V, Ie = 3 A) ∴ DC-13; R300 (Ue = 250 V, Ie = 0.1 A)</p>	~ AC-15; A300 (Ue = 240 V, Ie = 3 A), Ithe = 10 A ∴ DC-13; Q150 (Ue = 125 V, Ie = 0.55 A)	
Rated insulation voltage		Ui = 500 V degree of pollution 3 conforming to EN/IEC 60947-1 Ui = 300 V conforming to UL 508, CSA C22-2 n° 14		
Rated impulse withstand voltage		U imp = 6 kV conforming to EN/IEC 60947-1, IEC 60664		
Positive operation (depending on model)		NC contacts with positive opening operation conforming to EN/IEC 60947-5-1 Section 3 (except XCRT)	NC contacts with positive opening operation conforming to EN/IEC 60947-5-1 Section 3 (contacts 21-22)	
Resistance across terminals		≤ 25 m Ω conforming to NF C 93-050 method A or IEC 60255-7 category 3		
Short-circuit protection		10 A cartridge fuse type gG (gl)		
Connection	Screw clamp terminals	Clamping capacity	Clamping capacity	
		<p>XE2N P2151 ou XCRT: min: 1 x 0.5 mm², max: 2 x 2.5 mm²</p> <p>XE2S P2151: min: 1 x 0.34 mm², max: 2 x 1.5 mm²</p>	min: 1 x 0.5 mm ² max: 2 x 2.5 mm ²	

Limit switches

OsiSense XC Special

For hoisting and material handling applications XCR, XCKMR and XCKVR

For conveyor belt shift monitoring applications XCRT

Contact block characteristics (continued)

Electrical durability

- Conforming to EN/IEC 60947-5-1 Appendix C
- Utilisation categories AC-15 and DC-13
- Maximum operating rate: 3600 operating cycles/hour
- Load factor: 0.5

AC supply
~ 50/60 Hz
~ inductive circuit

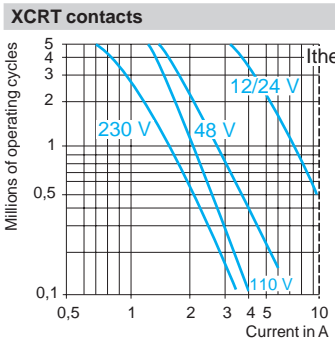
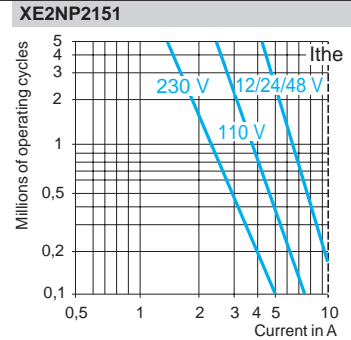
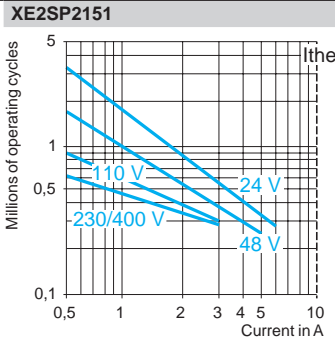

DC supply ---

	Voltage V	24	48	120
Power broken in W for	XE2S P2151	10	7	4
5 million operating cycles	XE2N P2151	13	9	7
W ~ inductive circuit	XCRT contacts	10	7	4

For XE2SP2151 on ~ or --- NC and NO contacts simultaneously loaded to the values shown with reverse polarity.

Limit switches

OsiSense XC Special

For hoisting and material handling applications XCR
Complete switches with 1 cable entry

Type of head	Rotary with spring return to off position	Stay put
Maximum displacement	55° in each direction	90° in each direction

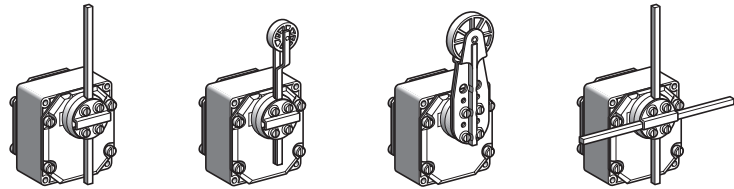

Type of operator	Metal rod, \varnothing 6 mm	Thermoplastic roller lever	Large thermoplastic roller lever	Metal rods, \varnothing 6 mm, crossed rods for XCRE●●, "T" rods for XCRF●●7
Rod length	1 rod of 200 mm	–	–	XCRE●●: 2 rods of 200 mm XCRF●●: 1 rod of 200 mm and 1 rod of 300 mm

References of complete switches (⊖ NC contact with positive opening operation)

<p>Two 2-pole NC + NO snap action XE2SP2151</p> <p>1st contact 2^e contact</p>	Both contacts operate in each direction	<p>XCRA11 ⊖ (3)</p>	<p>XCRA12 ⊖ (3)</p>	<p>XCRA15 ⊖ (3)</p>	<p>XCRE18 ⊖ (3)</p>
	1 contact operates in each direction	<p>XCRB11 ⊖ (3)</p>	<p>XCRB12 ⊖ (3)</p>	<p>XCRB15 ⊖ (3)</p>	<p>XCRF17 ⊖ (3)</p>
<p>Two 2-pole NC + NO break before make, slow break XE2NP2151</p> <p>1st contact 2^e contact</p>	Both contacts operate in each direction	<p>XCRA51 ⊖ (3)</p>	<p>XCRA52 ⊖ (3)</p>	<p>XCRA55 ⊖ (3)</p>	<p>XCRE58 ⊖ (3)</p>
	1 contact operates in each direction	<p>XCRB51 ⊖ (3)</p>	<p>XCRB52 ⊖ (3)</p>	<p>XCRB55 ⊖ (3)</p>	<p>XCRF57 ⊖ (3)</p>
Weight (kg)		1.110	1.145	1.155	1.135
Contact operation	<p>closed open</p>	<p>(P) = positive opening point (1) 1st contact (2) 2nd contact</p>			

Complementary characteristics

Lever maximum actuation speed	1.5 m/s	
Mechanical durability	10 million operating cycles	
Minimum torque	For tripping	0.45 N.m
	For positive opening	0.75 N.m
Cable entry	1 entry tapped for n° 13 cable gland conforming to NF C 68-300 (DIN Pg 13.5)	
	Clamping capacity 9 to 12 mm	

(3) For a limit switch with watertight reinforced seal (IP 65), add 1 to the end of the reference. Example: XCRF17 becomes XCRF171.

Limit switches

OsiSense XC Special

For hoisting and material handling applications XCR

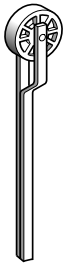

XCRZ02

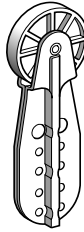

XCRZ05

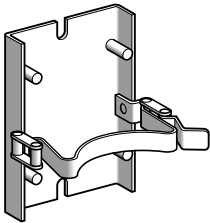

XCRZ09

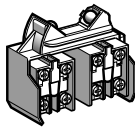

XCRZ12

Separate components

Description	For switches	Type	Reference	Weight kg
Rod, \varnothing 6 mm	XCRA XCRB XCRE XCRF	L = 200 mm	XCRZ03	0.020
	XCRF	L = 300 mm	XCRZ04	0.030
Roller lever thermoplastic roller	XCRA XCRB	–	XCRZ02	0.050
	XCRA XCRB	–	XCRZ05	0.090
Quick fixing/ release bracket	XCRA, XCRB XCRE, XCRF	–	XCRZ09	0.520
Contact block (2 contacts) with mounting plate	XCRA, XCRB XCRE, XCRF	2-pole NC + NO snap action	XCRZ12	0.135
		2-pole NC + NO break before make, snap action	XCRZ15	0.135
Description	Application	Sold in lots of	Unit reference	Weight kg
Adaptor	Pg 13.5 to ISO M20 x 1.5	5	DE9RP13520	0.032

Limit switches

OsiSense XC Special

For conveyor belt shift monitoring applications XCRT
Complete switches with 1 cable entry

1

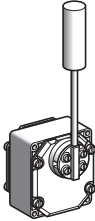
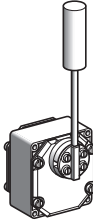
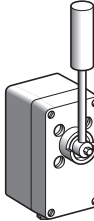
Type of switch	Standard	For corrosive atmospheres	
			
Features	Zinc alloy enclosure Colour: industrial blue Zinc plated steel lever, spring return to off position Cam angles: 10° and 18° Maximum displacement: 90°	Zinc alloy enclosure Colour: blue Stainless steel lever, spring return to off position Cam angles: 10° and 18° Maximum displacement: 90°	Glass reinforced polyester enclosure Colour: grey Stainless steel lever, spring return to off position Cam angles: 10° and 18° Maximum displacement: 70°

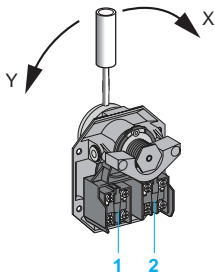
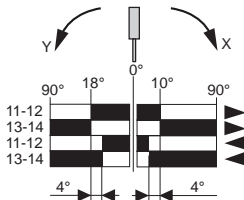
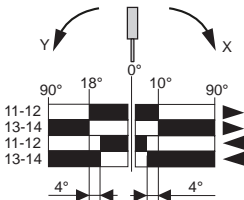
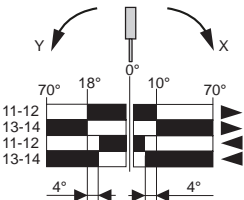
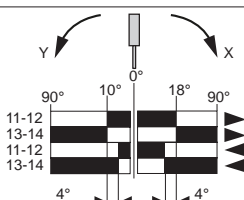
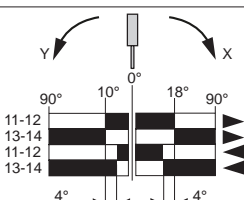
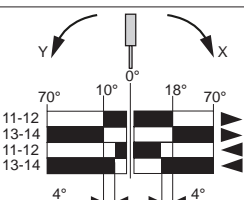
References of complete switches			
2 single-pole CO snap action	XCRT115	XCRT215	XCRT315
 <p>1: 1st contact</p> <p>2: 2nd contact</p>			
			
Weight (kg)	1.170	1.170	1.520

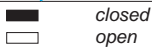
Contact operation 

Complementary characteristics	
Lever maximum actuation speed	1.5 m/s
Belt maximum speed	4 m/s
Machnical durability	0.3 million operating cycles
Minimum tripping torque	1.7 N.m
Cable entry	1 entry tapped for n° 13 cable gland conforming to NF C 68-300 (DIN Pg 13.5) Clamping capacity 9 to 12 mm

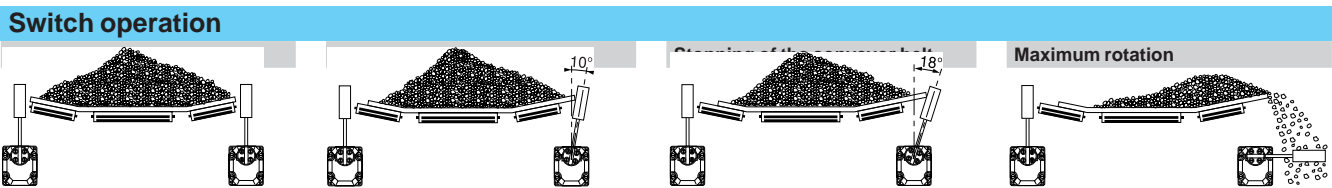

Limit switches

OsiSense XC Special

For conveyor belt shift monitoring applications XCRT

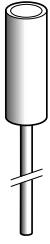

XCRZ9●●

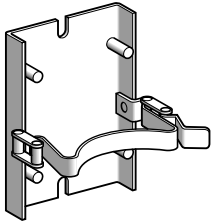

XCRZ09

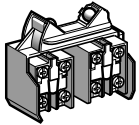

XCRZ42

Separate components

Description	Type	For switches	Reference	Weight kg
Roller with lever	Zinc plated steel	XCRT115 XCRT215	XCRZ901	0.230
	Stainless steel	XCRT115 XCRT215	XCRZ902	0.230
		XCRT315	XCRZ903	0.230
Quick fixing/release bracket	–	XCRT115 XCRT215	XCRZ09	0.520
Contact block (2 contacts) with mounting plate	Single-pole CO snap action	XCRT●15	XCRZ42	0.135
Description	Application	Sold in lots of	Unit reference	Weight kg
Adaptor	Pg 13.5 to ISO M20 x 1.5	5	DE9RP13520	0.032

Limit switches

OsiSense XC Special

For hoisting and material handling applications XCR

1

XCRA11, XCRB11, XCRA51, XCRB51

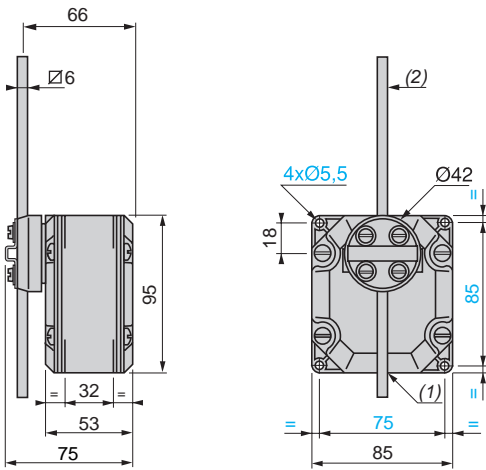

XCRA12, XCRB12, XCRA52, XCRB52

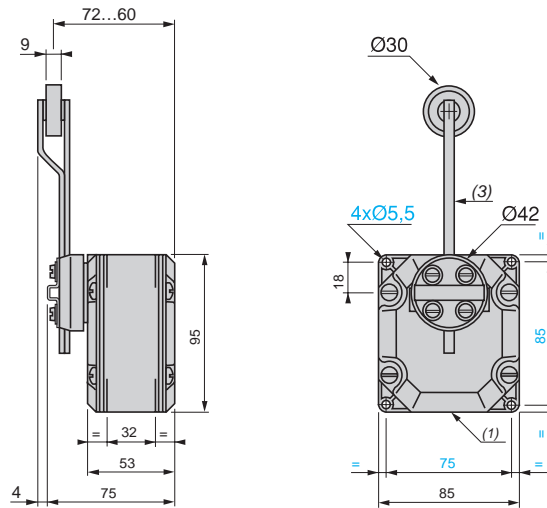

XCRA15, XCRB15, XCRA55, XCRB55

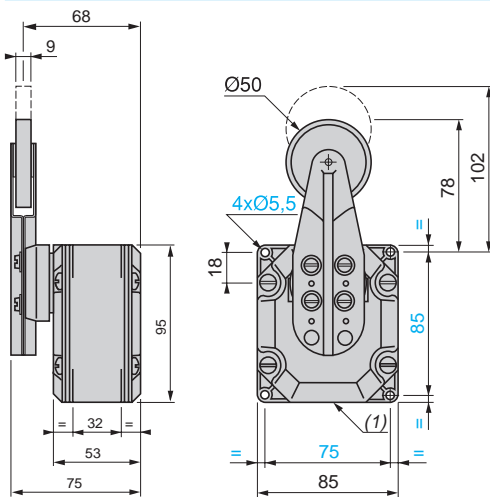

XCRE18, XCRE58, XCRF17, XCRF57

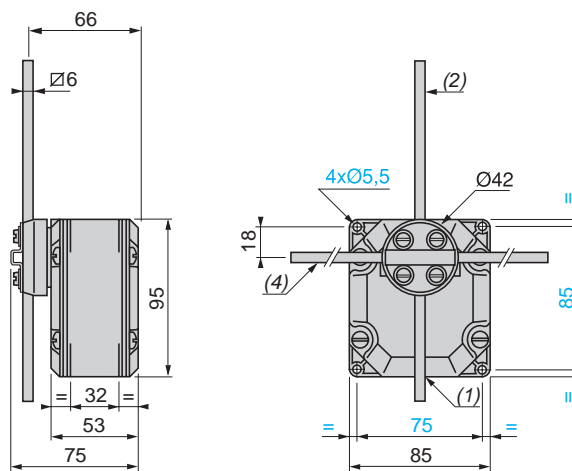

(1) 1 tapped entry for n° 13 cable gland.

(2) Rod length: 200 mm.

(3) Rod + roller length: 160 mm.

(4) Rod length: 300 mm for XCRF17 and XCRF57, 200 mm for XCRE18 and XCRE58.

Supplementary fixing using 2 adjustable lugs (included with switch)

Horizontally positioned

Vertically positioned

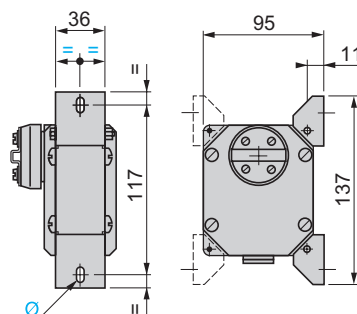
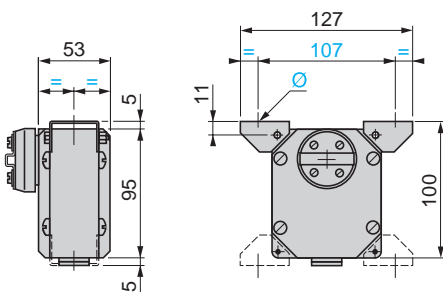

Quick fixing/release bracket XCRZ09

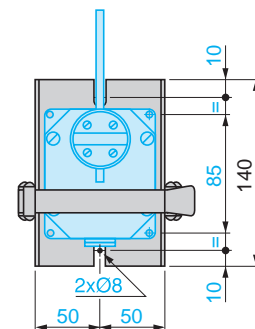

Ø: 1 elongated hole Ø 6 x 8.

Limit switches

OsiSense XC Special

For conveyor belt shift monitoring applications XCRT

XCRT115, XCRT215

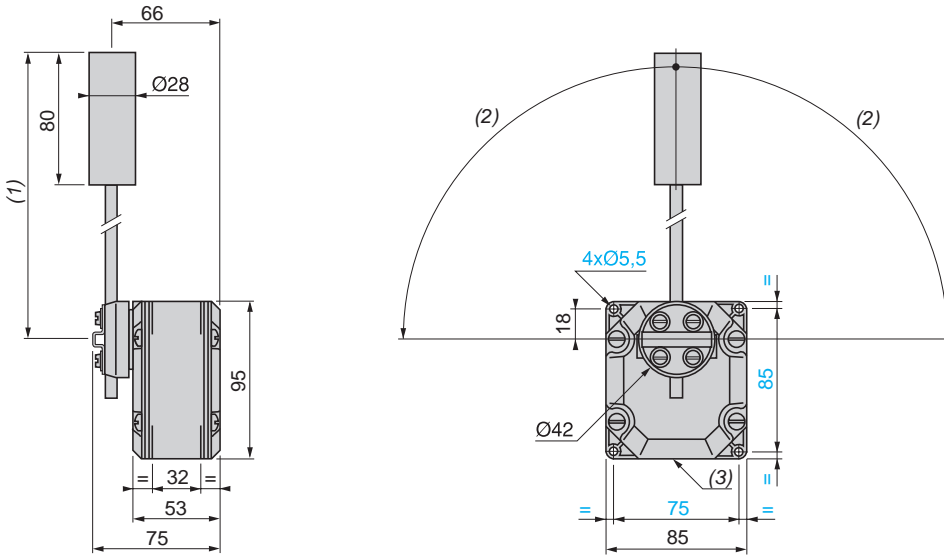

XCRT315

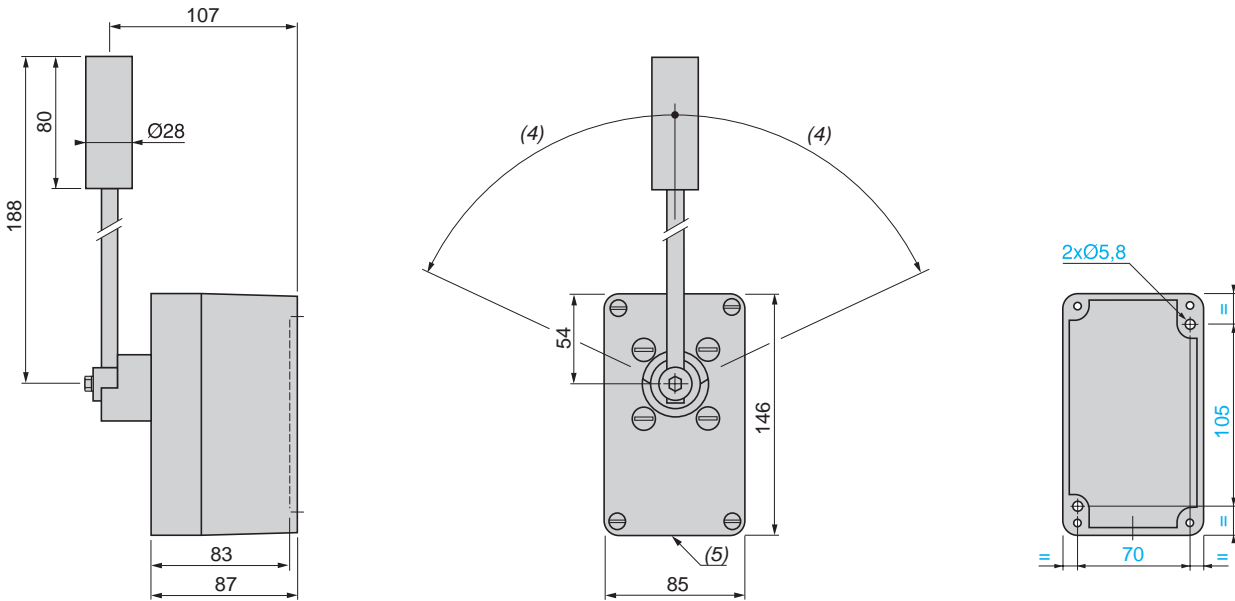

(1) 200 max., 104 min.

(2) 90° max.

(3) 1 tapped entry for n° 13 cable gland.

(4) 70° max.

(5) 1 plain entry for n° 13 cable gland.

Supplementary fixing using 2 adjustable lugs (included with XCRT115 and XCRT215)

Horizontally positioned

Vertically positioned

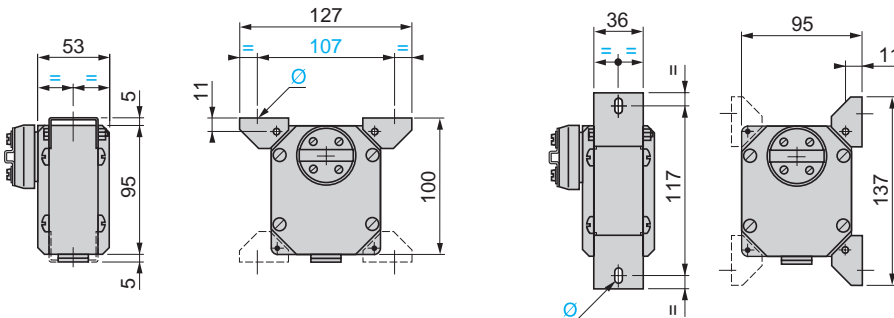

Quick fixing/release bracket XCRZ09

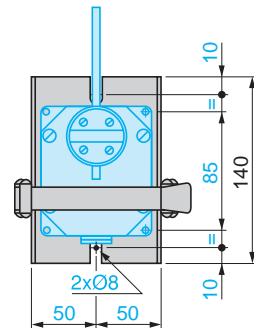

Ø: 1 elongated hole Ø 6 x 8.

Limit switches

OsiSense XC Special

For hoisting and material handling applications

XCKMR and XCKVR

Complete switches with 3 cable entries

1

Type of operating head	Rotary			

Material	Metal		Plastic	
Type of operator	With cruciform metal rods	With cruciform metal rods, reversed head	With cruciform metal rods	With cruciform metal rods, reversed head

References

"By pass" switches						
		2 x 2-pole NC+NO break before make, slow break (XE2NP2151)	XCKMR24SR1H29	–	XCKVR24SR1H29	–
"Single speed" switches						
		2 x 2-pole NC+NO break before make, slow break (XE2NP2151)	XCKMR44D1H29	XCKMR44D2H29	XCKVR44D1H29	XCKVR44D2H29
"Double speed" switches (⊖ NC contact with positive opening operation on contacts 21-22)						
		2 x 2-pole NC+NC break before make, slow break (non interchangeable contacts)	XCKMR54D1H29 (1)	XCKMR54D2H29 (1)	XCKVR54D1H29	XCKVR54D2H29
Weight (kg)			0.684	0.684	0.320	0.320

Complementary characteristics

Switch actuation	Horizontal	
Permissible actuation area on the rods	Between 65 and 95 mm from the axis of the fixing screws on the body	
Minimum actuation speed	0.1 m/mn	0.1 m/mn
Maximum actuation speed (2)	1.5 m/s	1.5 m/s
Minimum force or torque	For tripping	0.5 N.m
	For positive opening	0.75 N.m
Mechanical durability	2 million operating cycles	1 million operating cycles
Setting up	Rods included with the switch: for customer assembly	

References of separate components

	Description	Reference	Weight kg
	Rod ∅ 6 mm, L = 200 mm	XCRZ03	0.020
	Rod ∅ 6 mm, L = 200 mm with red mark	XCRZ03R	0.020
	Plastic cable gland ISO M20	DE9PEM20010	0.010

(1) For complete switches with entry for Pg 13.5 cable gland, delete H29 from the end of the reference. Example: XCKMR54D1H29 becomes XCKMR54D1.
 (2) For an actuation point on the rod between 65 and 95 mm from the axis of the fixing screws on the body.

Limit switches

OsiSense XC Special

For hoisting and material handling applications

XCKMR and XCKVR

Complete switches with 3 cable entries

Dimensions

Metal limit switches

XCKMR24SR1H29,
XCKMR44D1H29 and
XCKMR54D1H29

XCKMR44D2H29 and XCKMR54D2H29

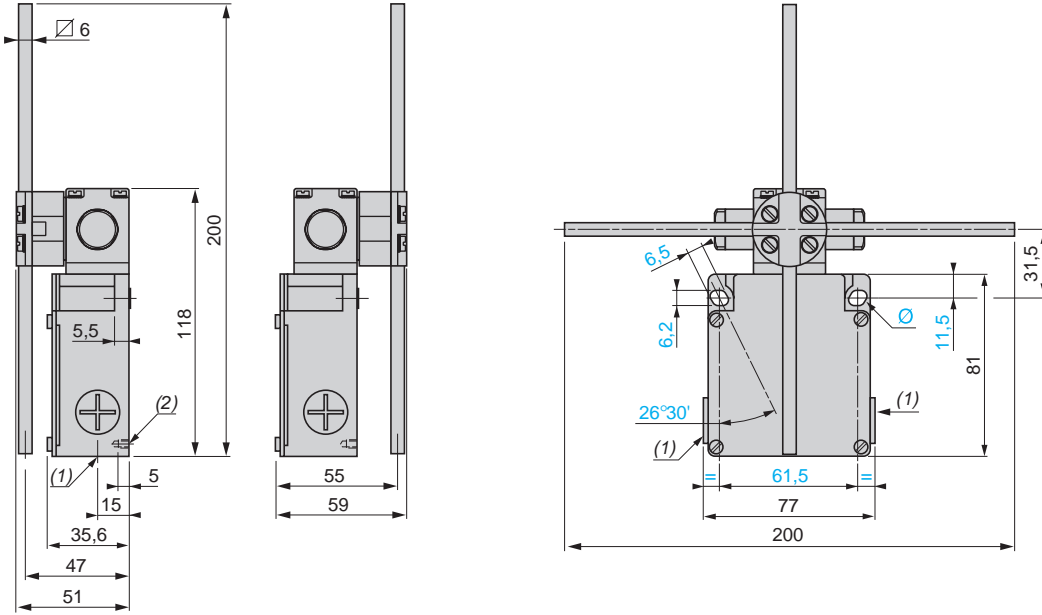

(1) XCKMR●●●H29 = 3 tapped entries ISO M20 x 1.5.

XCKMR●●● = 3 tapped entries for Pg 13.5 cable gland.

(2) 2 centring holes $\varnothing 3.9 \pm 0.2$, for cover fixing holes alignment.

\varnothing : 2 elongated holes 6.2 x 6.5, inclined at 26°30' to the vertical axis, for M5 screws.

Plastic limit switches

XCKVR24SR1H29,
XCKVR44D1H29 and
XCKVR54D1H29

XCKVR44D2H29 and XCKVR54D2H29

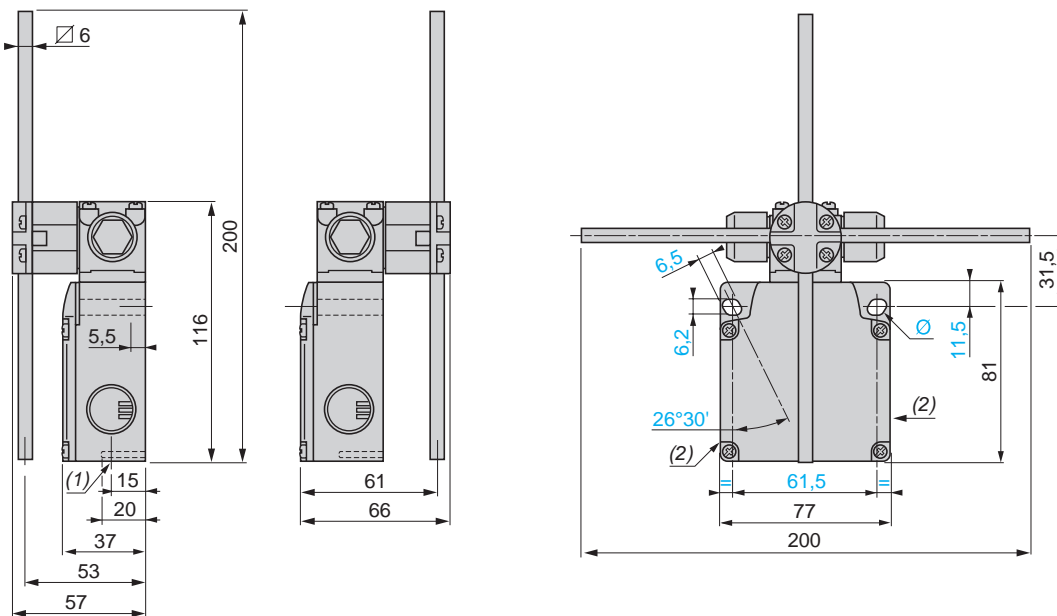

(1) 1 tapped entry ISO M20 x 1.5.

(2) 2 knock-out holes for ISO M20 cable gland (reference: DE9 PEM20010).

\varnothing : 2 elongated holes 6.2 x 6.5, inclined at 26°30' to the vertical axis, for M5 screws.

Limit switches

OsiSense XC Special

For hoisting and material handling applications

XCKMR and XCKVR

Complete switches with 3 cable entries

Operation (continued)

Limit switches XCK●R54D●●●●: "Double speed"

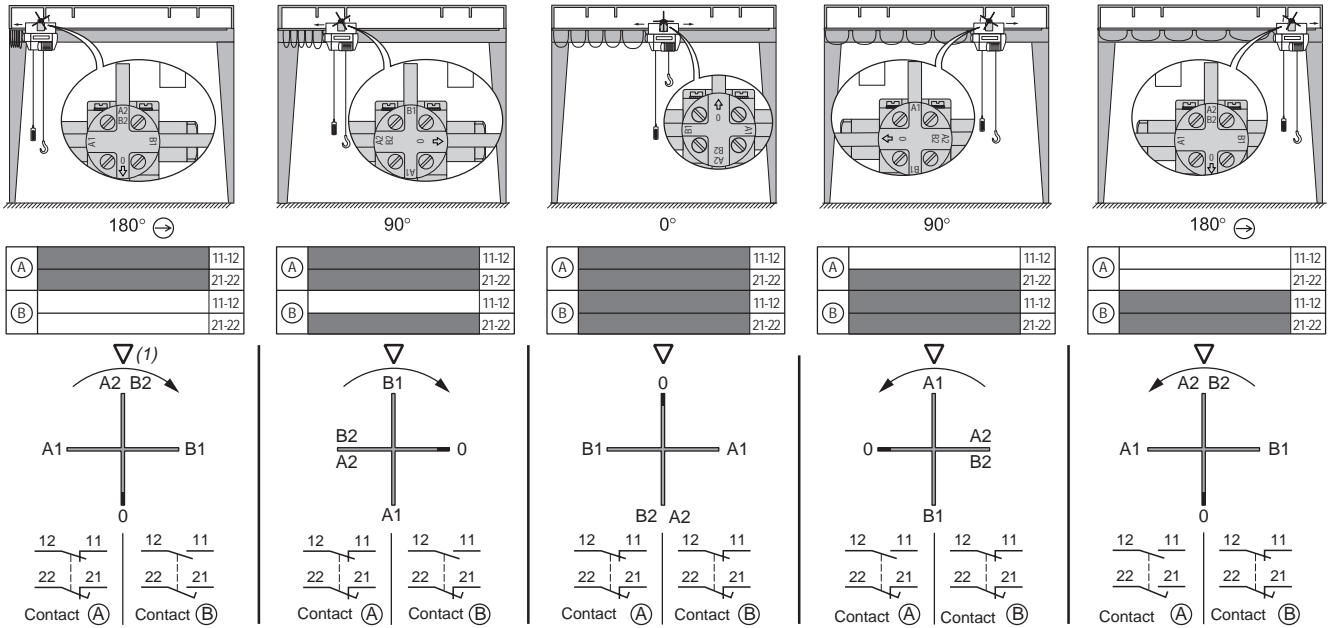

(1) Triangle symbol marked on top of head.

or → : direction of rotation.