

Limit switches

XC Standard range

Miniature design, metal, XCMV

for mobile equipment

The range of XCMV limit switches is an offer dedicated to mobile equipment:

- special connectors
- a metal body for robustness
- compact dimensions (among the smallest on the market)
- IP 69 degree of protection, for high-pressure cleaning
- for outdoor use at -25 °...+70 °C

Complete units
with Deutsch DT04-4P connector

□ With head for linear (plunger) and rotary (lever) movement



Page 53

Complete units
with AMP Superseal 1.5 connector

□ With head for linear (plunger) and rotary (lever) movement



Page 54

Complete units
with M12 connector

□ With head for linear (plunger) and rotary (lever) movement



Page 55

Limit switches

XC Standard range
Miniature design, metal, XCMV
for mobile equipment

Modular units

Body with Deutsch DT04-4P connector

□ With head for linear (plunger) and rotary (lever) movement



Pages 56 and 57

Modular units

Body with AMP Superseal 1.5 connector

□ With head for linear (plunger) and rotary (lever) movement



Pages 58 and 59

Modular units

Body with M12 connector

□ With head for linear (plunger) and rotary (lever) movement



Pages 60 and 61

Modular units

Pre-cabled body

□ With head for linear (plunger) and rotary (lever) movement



Pages 62 and 63

Limit switches

XC Standard range

Miniature design, metal, XCMV
for mobile equipment

Environmental characteristics		
Product certifications		CE, cURus
Conformity to standards	Products	EN/IEC 60947-5-1, UL 508, CSA C22-2 n°14, GB/T 14048.5
	Machine assemblies	EN/IEC 60204-1
Protective treatment		Standard version: "TC"
Ambient air temperature	For operation	- 25...+ 70 °C (- 40...+ 70 °C with ZCE106, ZCE026 and ZCE016 heads)
	For storage	- 40...+ 70 °C
Vibration resistance		± 1.76 mm (10...60 Hz), 25 gn (61...500 Hz) conforming to IEC 60068-2-6
Shock resistance		40 gn (11 ms) conforming to IEC 60068-2-27
Protection against electric shock		Class III conforming to IEC 61140, class 2 conforming to UL 508
Degree of protection	Switches with 4-pin M12 connector	IP 66, IP 67 and IP 69 conforming to EN/IEC 60529 ; IK 04 conforming to EN 62262
	Switches with 4-pin Deutsch DT04-4P or AMP Superseal 1.5 connector	IP 66, IP 67 and IP 69 conforming to EN/IEC 60529 ; IK 06 conforming to EN 62262
	Pre-cabled switches	IP 66 and IP 67 conforming to EN/IEC 60529
Materials		Body: Zamak, heads: Zamak, connectors: thermoplastic, cable: PvR
Repeat accuracy		0.1 mm on the tripping points, with 1 million operating cycles for head with end plunger

Contact block characteristics		
Rated operational characteristics	Switches with 4-pin M12 connector	~ AC-14; Ue = 24 V, Ie = 3 A, Ith = 4 A --- DC-13; Ue = 24 V, Ie = 1 A, conforming to IEC 60947-5-1, EN 60947-5-1
	Pre-cabled switches or switches with 4-pin Deutsch DT04-4P or AMP Superseal 1.5 connector	~ AC-14; Ue = 24 V, Ie = 3 A, Ith = 6 A --- DC-13; Ue = 24 V, Ie = 1 A, conforming to IEC 60947-5-1, EN 60947-5-1
Rated insulation voltage		Ui = 36 V degree of pollution 3 conforming to IEC 60947-5-1 Ui = 36 V conforming to UL 508, CSA C22-2 no. 14
Rated impulse withstand voltage		U imp = 0.8 kV conforming to IEC 60947-1, IEC 60664
Positive operation (depending on model)		NC contacts with positive opening operation conforming to IEC 60947-5-1
Resistance across terminals		≤ 25 mΩ conforming to IEC 60255-7 category 3
Short-circuit protection.		6 A cartridge fuse type gG (gl)
Minimum actuation speed (for head with end plunger)		Snap-action contact: 0.01 m/minute, slow-break contact: 6 m/minute
Electrical durability		<ul style="list-style-type: none"> ■ Conforming to IEC 60947-5-1 Appendix C ■ Utilisation categories AC-14 and DC-13 ■ Maximum operating rate: 3600 operating cycles/hour ■ Load factor: 0.5

AC supply
~ 50/60 Hz
m inductive circuit

XCMV snap-action (NC+NO contact)

XCMV slow-break (NC+NO contact)

Switches with M12 connector

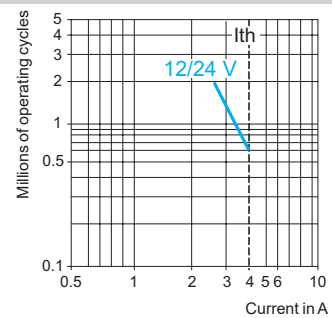
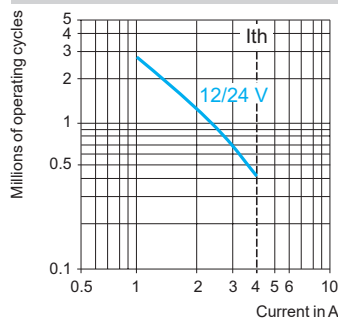

Pre-cabled switches or switches with Deutsch DT04-4P or AMP Superseal 1.5 connector

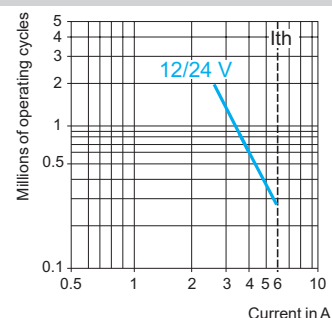
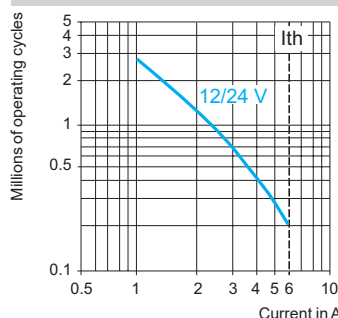

DC supply ---

Power broken in W for
0.1 million operating cycles

Voltage	V	24
m	A	2

Power broken in W for
1.3 million operating cycles

Voltage	V	24
m	A	0.5

Limit switches

XC Standard range
Miniature design, metal, XCMV
Complete units for mobile equipment

Type of head	Plunger (fixing by the body)	Rotary (fixing by the body)
--------------	------------------------------	-----------------------------



Form conforming to EN 50047	B	C	A
Type of operator	Metal end plunger	Steel roller plunger	Thermoplastic roller lever (1)
Positive operation			

References of complete units with male Deutsch DT04-4P connector

2-pole NC + NO snap action	XCMV2110D44 	XCMV2102D44 	XCMV2115D44
2-pole NC + NO break before make, slow break	XCMV2510D44 	XCMV2502D44 	XCMV2515D44
Weight (kg)	0.090	0.090	0.130

Contact operation closed open (A) = cam displacement (P) = positive opening point

Complementary characteristics not shown under general characteristics (see page 51)

Switch actuation	On end	By 30° cam	
Type of actuation			
Maximum actuation speed	0.5 m/s	0.5 m/s	1.5 m/s
Mechanical durability (in millions of operating cycles)	10		
Minimum force or torque	For tripping	8.5 N	7 N
	For positive opening	42.5 N	35 N
			0.1 N.m
			0.5 N.m

(1) Can be adjusted throughout 360° in 15° steps.

Limit switches

XC Standard range
Miniature design, metal, XCMV
Complete units for mobile equipment

Type of head	Plunger (fixing by the body)	Rotary (fixing by the body)
--------------	------------------------------	-----------------------------



Form conforming to EN 50047	B	C	A
Type of operator	Metal end plunger	Steel roller plunger	Thermoplastic roller lever (1)
Positive operation			

References of complete units with male AMP Superseal 1.5 connector

2-pole NC + NO snap action	XCMD2110AM4 	XCMD2102AM4 	XCMD2115AM4
2-pole NC + NO break before make, slow break	XCMD2510AM4 	XCMD2502AM4 	XCMD2515AM4
Weight (kg)	0.090	0.090	0.130
Contact operation			(A) = cam displacement (P) = positive opening point

Characteristics

Switch actuation	On end	By 30° cam	
Type of actuation			
Maximum actuation speed	0.5 m/s	0.5 m/s	1.5 m/s
Mechanical durability (in millions of operating cycles)	10		
Minimum force or torque	For tripping	8.5 N	7 N
	For positive opening	42.5 N	35 N
			0.1 N.m
			0.5 N.m

(1) Can be adjusted throughout 360° in 15° steps.

Limit switches

XC Standard range

Miniature design, metal, XCMV

Complete units for mobile equipment

Type of head	Plunger (fixing by the body)	Rotary (fixing by the body)
--------------	------------------------------	-----------------------------



Form conforming to EN 50047	B	C	A
Type of operator	Metal end plunger	Steel roller plunger	Thermoplastic roller lever (1)
Positive operation			

References of complete units with M12 connector

2-pole NC + NO snap action	XCMV2110M12 	XCMV2102M12 	XCMV2115M12
2-pole NC + NO break before make, slow break	XCMV2510M12 	XCMV2502M12 	XCMV2515M12
Weight (kg)	0.090	0.090	0.130

Contact operation		(A) = cam displacement (P) = positive opening point	
-------------------	--	--	--

Complementary characteristics not shown under general characteristics (see page 51)

Switch actuation	On end	By 30° cam	
Type of actuation			
Maximum actuation speed	0.5 m/s	0.5 m/s	1.5 m/s
Mechanical durability (in millions of operating cycles)	10		
Minimum force or torque	For tripping	8.5 N	7 N
	For positive opening	42.5 N	35 N
			0.1 N.m
			0.5 N.m

(1) Can be adjusted throughout 360° in 15° steps.

Limit switches

XC Standard range
Miniature design, metal, XCMV
Modular units for mobile equipment

Type of head	Plunger (fixing by the body)							Plunger (fixing by the head)	Rotary (fixing by the body)					Multi-directional	
Type of operator	Metal end plunger	Metal end plunger -40 °C (1)	Metal end plunger with elastomer boot (2)	Steel roller plunger	Steel roller plunger -40 °C (1)	Retractable steel roller lever plunger	M12 with metal end plunger	M16 with metal end plunger with elastomer boot	M12 with steel roller plunger	Thermoplastic roller lever	Thermoplastic roller lever -40 °C (1)	Steel roller lever	Roller lever with ball bearing mounted roller	Variable length thermoplastic roller lever	"Cat's whisker" (3)

References of modular units (body with male Deutsch DT04-4P connector and removable terminal block)															
2-pole NC + NO snap action	ZCMV21D44 + ZCE10	ZCMV21D44 + ZCE106	ZCMV21D44 + ZCE11	ZCMV21D44 + ZCE02	ZCMV21D44 + ZCE026	ZCMV21D44 + ZCE24	ZCMV21D44 + ZCEF0	ZCMV21D44 + ZCEG1	ZCMV21D44 + ZCEF2	ZCMV21D44 + ZCY15	ZCMV21D44 + ZCE016 + ZCY15	ZCMV21D44 + ZCE01 + ZCY16	ZCMV21D44 + ZCE01 + ZCY17	ZCMV21D44 + ZCE01 + ZCY45	ZCMV21D44 + ZCE06
		1.8 4.2(P)	1.8 4.2(P)	1.8 4.2(P)	3.1(A) 7(P)	3.1(A) 7(P)	11.2(A) 25(P)	1.8 4.2(P)	1.8 4.2(P)	3.1(A) 7(P)	25° 70°(P)	25° 70°(P)	25° 70°(P)	25° 70°(P)	25° 70°(P)
2-pole NC + NO break before make, slow break	ZCMV25D44 + ZCE10	ZCMV25D44 + ZCE106	ZCMV25D44 + ZCE11	ZCMV25D44 + ZCE02	ZCMV25D44 + ZCE026	ZCMV25D44 + ZCE24	ZCMV25D44 + ZCEF0	ZCMV25D44 + ZCEG1	ZCMV25D44 + ZCEF2	ZCMV25D44 + ZCY15	ZCMV25D44 + ZCE016 + ZCY15	ZCMV25D44 + ZCE01 + ZCY16	ZCMV25D44 + ZCE01 + ZCY17	ZCMV25D44 + ZCE01 + ZCY45	ZCMV25D44 + ZCE06
		1.8 3.1(P)	1.8 3.1(P)	1.8 3.1(P)	3.1(A) 5.6(P)	3.1(A) 5.6(P)	11.2(A) 19.5(P)	1.8 3.1(P)	1.8 3.1(P)	3.1(A) 5.6(P)	25° 45°(P)	25° 45°(P)	25° 45°(P)	25° 45°(P)	25° 45°(P)
2-pole NC + NC snap action	ZCMV29D44 + ZCE10	ZCMV29D44 + ZCE106	ZCMV29D44 + ZCE11	ZCMV29D44 + ZCE02	ZCMV29D44 + ZCE026	ZCMV29D44 + ZCE24	ZCMV29D44 + ZCEF0	ZCMV29D44 + ZCEG1	ZCMV29D44 + ZCEF2	ZCMV29D44 + ZCY15	ZCMV29D44 + ZCE016 + ZCY15	ZCMV29D44 + ZCE01 + ZCY16	ZCMV29D44 + ZCE01 + ZCY17	ZCMV29D44 + ZCE01 + ZCY45	ZCMV29D44 + ZCE06
		1.8 4.2(P)	1.8 4.2(P)	1.8 4.2(P)	3.1(A) 7(P)	3.1(A) 7(P)	11.2(A) 25(P)	1.8 4.2(P)	1.8 4.2(P)	3.1(A) 7(P)	25° 70°(P)	25° 70°(P)	25° 70°(P)	25° 70°(P)	25° 70°(P)
Contact operation	(A) = cam displacement (P) = positive opening point							(A) = cam displacement (P) = positive opening point							(A) = cam displacement (P) = positive opening point

Complementary characteristics not shown under general characteristics (see page 51)																			
Switch actuation	On end				By 30° cam				On end				By any moving part						
Type of actuation																			
Maximum actuation speed	0.5 m/s								0.5 m/s				1.5 m/s						
Mechanical durability	10 million operating cycles								10 million operating cycles				10 million						
Nominal force or torque	For tripping				7 N				2.5 N				8.5 N						
	For positive opening				42.5 N				35 N				12.5 N				42.5 N		
Connection	Deutsch DT04-4P connector																		

(1) For use at -40 °C.
(2) Nitrile for indoor use.
(3) Value taken with actuation by moving part at 100 mm from the fixing.

Limit switches

XC Standard range
Miniature design, metal, XCMV
Modular units for mobile equipment

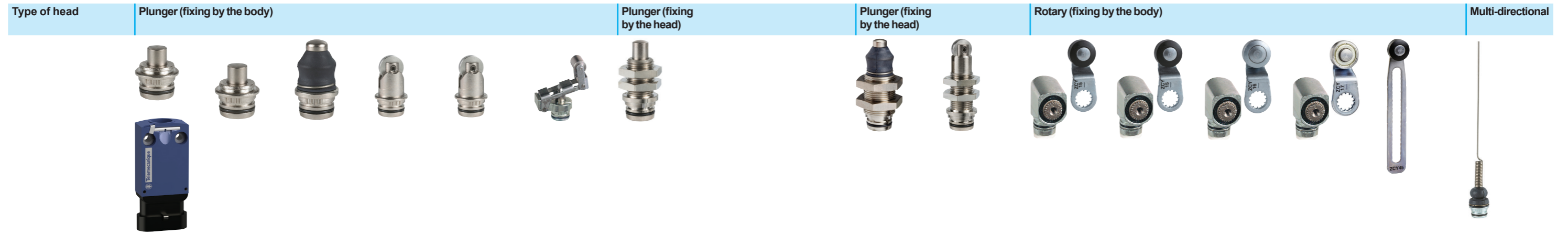

Type of head	Plunger (fixing by the body)							Plunger (fixing by the head)	Plunger (fixing by the head)	Rotary (fixing by the body)					Multi-directional
Type of operator	Metal end plunger	Metal end plunger -40 °C (1)	Metal end plunger with elastomer boot (2)	Steel roller plunger	Steel roller plunger -40 °C (1)	Retractable steel roller lever plunger	M12 with metal end plunger	M16 with metal end plunger with elastomer boot	M12 with steel roller plunger	Thermoplastic roller lever	Thermoplastic roller lever -40 °C (1)	Steel roller lever	Roller lever with ball bearing mounted roller	Variable length thermoplastic roller lever	"Cat's whisker" (3)

References of modular units (body with male AMP Superseal 1.5 connector and removable terminal block)

Type of operator	Plunger (fixing by the body)							Plunger (fixing by the head)	Plunger (fixing by the head)	Rotary (fixing by the body)					Multi-directional	
2-pole "NC + NO" snap action	ZCMD21AM4 + ZCE10	ZCMD21AM4 + ZCE106	ZCMD21AM4 + ZCE11	ZCMD21AM4 + ZCE02	ZCMD21AM4 + ZCE026	ZCMD21AM4 + ZCE24	ZCMD21AM4 + ZCEF0	ZCMD21AM4 + ZCEG1	ZCMD21AM4 + ZCEF2	ZCMD21AM4 + ZCE01 + ZCY15	ZCMD21AM4 + ZCE016 + ZCY15	ZCMD21AM4 + ZCE01 + ZCY16	ZCMD21AM4 + ZCE01 + ZCY17	ZCMD21AM4 + ZCE01 + ZCY45	ZCMD21AM4 + ZCE06	
2-pole NC + NO break before make, slow break	ZCMD25AM4 + ZCE10	ZCMD25AM4 + ZCE106	ZCMD25AM4 + ZCE11	ZCMD25AM4 + ZCE02	ZCMD25AM4 + ZCE026	ZCMD25AM4 + ZCE24	ZCMD25AM4 + ZCEF0	ZCMD25AM4 + ZCEG1	ZCMD25AM4 + ZCEF2	ZCMD25AM4 + ZCE01 + ZCY15	ZCMD25AM4 + ZCE016 + ZCY15	ZCMD25AM4 + ZCE01 + ZCY16	ZCMD25AM4 + ZCE01 + ZCY17	ZCMD25AM4 + ZCE01 + ZCY45	ZCMD25AM4 + ZCE06	
2-pole NC + NC snap action	ZCMD29AM4 + ZCE10	ZCMD29AM4 + ZCE106	ZCMD29AM4 + ZCE11	ZCMD29AM4 + ZCE02	ZCMD29AM4 + ZCE026	ZCMD29AM4 + ZCE24	ZCMD29AM4 + ZCEF0	ZCMD29AM4 + ZCEG1	ZCMD29AM4 + ZCEF2	ZCMD29AM4 + ZCE01 + ZCY15	ZCMD29AM4 + ZCE016 + ZCY15	ZCMD29AM4 + ZCE01 + ZCY16	ZCMD29AM4 + ZCE01 + ZCY17	ZCMD29AM4 + ZCE01 + ZCY45	ZCMD29AM4 + ZCE06	
Contact operation																
	(A) = cam displacement (P) = positive opening point							(A) = cam displacement (P) = positive opening point							(A) = cam displacement (P) = positive opening point	

Complementary characteristics not shown under general characteristics (see page 51)

Switch actuation	On end	By 30° cam	On end	On end	By 30° cam	By any moving part
Type of actuation						
Maximum actuation speed	0.5 m/s				0.1 m/s	1.5 m/s
Mechanical durability	10 million operating cycles					10 million
Nominal force or torque	For tripping: 8.5 N	7 N	2.5 N	8.5 N	7 N.m	0.1 N.m
	For positive opening: 42.5 N	35 N	12.5 N	42.5 N	0.1 N.m	0.1 N.m
Connection	Male AMP Superseal 1.5 connector					0.5 N.m

(1) For use at -40 °C.
(2) Nitrile for indoor use.
(3) Value taken with actuation by moving part at 100 mm from the fixing.

Limit switches

XC Standard range
Miniature design, metal, XCMV
Modular units for mobile equipment

Type of head	Plunger (fixing by the body)							Plunger (fixing by the head)	Plunger (fixing by the head)					Rotary (fixing by the body)				Multi-directional
Type of operator	Metal end plunger	Metal end plunger -40 °C (1)	Metal end plunger with elastomer boot (2)	Steel roller plunger	Steel roller plunger -40 °C (1)	Retractable steel roller lever plunger	M12 with metal end plunger	M16 with metal end plunger with elastomer boot	M12 with steel roller plunger	Thermoplastic roller lever	Thermoplastic roller lever -40 °C (1)	Steel roller lever	Roller lever with ball bearing mounted roller	Variable length thermoplastic roller lever	"Cat's whisker" (3)			

References of modular units (body with male M12 connector and removable terminal block)															
2-pole "NC + NO" snap action	ZCMV21M12 + ZCE10	ZCMV21M12 + ZCE106	ZCMV21M12 + ZCE11	ZCMV21M12 + ZCE02	ZCMV21M12 + ZCE026	ZCMV21M12 + ZCE24	ZCMV21M12 + ZCEF0	ZCMV21M12 + ZCEG1	ZCMV21v + ZCEF2	ZCMV21M12 + ZCE01 + ZCY15	ZCMV21M12 + ZCE016 + ZCY15	ZCMV21M12 + ZCE01 + ZCY16	ZCMV21M12 + ZCE01 + ZCY17	ZCMV21M12 + ZCE01 + ZCY45	ZCMV21M12 + ZCE06
2-pole NC + NO break before make, slow break	ZCMV25M12 + ZCE10	ZCMV25M12 + ZCE106	ZCMV25M12 + ZCE11	ZCMV25M12 + ZCE02	ZCMV25M12 + ZCE026	ZCMV25M12 + ZCE24	ZCMV25M12 + ZCEF0	ZCMV25M12 + ZCEG1	ZCMV25M12 + ZCEF2	ZCMV25M12 + ZCE01 + ZCY15	ZCMV25M12 + ZCE016 + ZCY15	ZCMV25M12 + ZCE01 + ZCY16	ZCMV25M12 + ZCE01 + ZCY17	ZCMV25M12 + ZCE01 + ZCY45	ZCMV25M12 + ZCE06
2-pole NC + NC snap action	ZCMV29M12 + ZCE10	ZCMV29M12 + ZCE106	ZCMV29M12 + ZCE11	ZCMV29M12 + ZCE02	ZCMV29M12 + ZCE026	ZCMV29M12 + ZCE24	ZCMV29M12 + ZCEF0	ZCMV29M12 + ZCEG1	ZCMV29M12 + ZCEF2	ZCMV29M12 + ZCE01 + ZCY15	ZCMV29M12 + ZCE016 + ZCY15	ZCMV29M12 + ZCE01 + ZCY16	ZCMV29M12 + ZCE01 + ZCY17	ZCMV29M12 + ZCE01 + ZCY45	ZCMV29M12 + ZCE06
Contact operation	closed open (A) = cam displacement (P) = positive opening point ⊕ NC contact with positive opening operation							closed open (A) = cam displacement (P) = positive opening point ⊕ NC contact with positive opening operation				closed open (A) = cam displacement (P) = positive opening point ⊕ NC contact with positive opening operation			

Complementary characteristics not shown under general characteristics (see page 51)																			
Switch actuation	On end				By 30° cam				On end				By any moving part						
Type of actuation																			
Maximum actuation speed	0.5 m/s								0.5 m/s				1.5 m/s						
Mechanical durability	10 million operating cycles								10 million operating cycles				10 million						
Nominal force or torque	For tripping				7 N				2.5 N				8.5 N						
	For positive opening				42.5 N				35 N				12.5 N				42.5 N		
Connection	M12 connector																		

(1) For use at -40 °C.
 (2) Nitrile for indoor use.
 (3) Value taken with actuation by moving part at 100 mm from the fixing.

Limit switches

XC Standard range
Miniature design, metal, XCMV
Modular units for mobile equipment

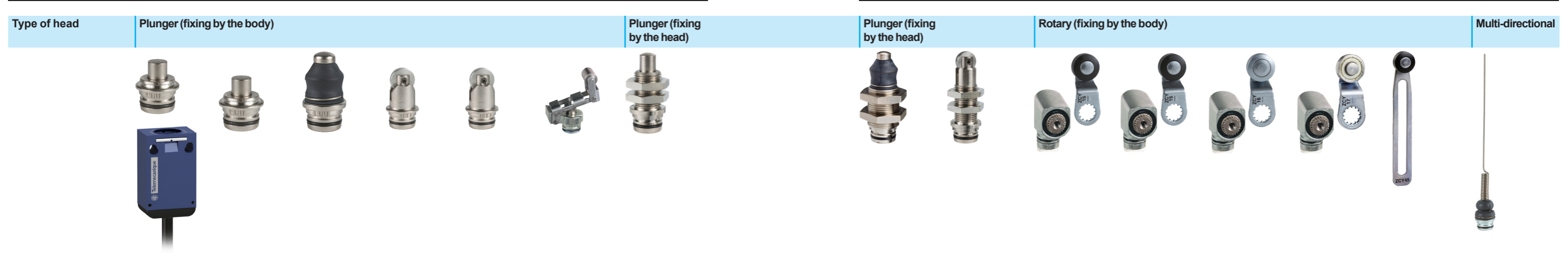

Type of head	Plunger (fixing by the body)							Plunger (fixing by the head)		Rotary (fixing by the body)					Multi-directional
Type of operator	Metal end plunger	Metal end plunger -40 °C (1)	Metal end plunger with elastomer boot (2)	Steel roller plunger	Steel roller plunger -40 °C (1)	Retractable steel roller plunger	M12 with metal end plunger	M16 with metal end plunger with elastomer boot	M12 with steel roller plunger	Thermoplastic roller lever	Thermoplastic roller lever -40 °C (1)	Steel roller lever	Roller lever with ball bearing mounted roller	Variable length thermoplastic roller lever	"Cat's whisker" (3)

References of modular units (pre-cabled body and removable terminal block)															
4-pole 2 NC + 2 NO snap action	ZCMV41L03 + ZCE10	ZCMV41L03 + ZCE106	ZCMV41L03 + ZCE11	ZCMV41L03 + ZCE02	ZCMV41L03 + ZCE026	ZCMV41L03 + ZCE24	ZCMV41L03 + ZCE00	ZCMV41L03 + ZCE01	ZCMV41L03 + ZCE02	ZCMV41L03 + ZCE01 + ZCY15	ZCMV41L03 + ZCE016 + ZCY15	ZCMV41L03 + ZCE01 + ZCY16	ZCMV41L03 + ZCE01 + ZCY17	ZCMV41L03 + ZCE01 + ZCY45	ZCMV41L03 + ZCE06
Contact operation	■ closed □ open		(A) = cam displacement (P) = positive opening point		⊖ NC contact with positive opening operation		■ closed □ open		(A) = cam displacement (P) = positive opening point		⊕ NC contact with positive opening operation				

Complementary characteristics not shown under general characteristics (see page 52)																
Switch actuation	On end				By 30° cam				On end			On end			By any moving part	
Type of actuation																
Maximum actuation speed	0.5 m/s				0.5 m/s				0.1 m/s			1.5 m/s			1.5 m/s	1 m/s
Mechanical durability	10 million operating cycles				10 million operating cycles				10 million operating cycles			10 million			5 million	
Nominal force or torque	For tripping				7 N				2.5 N			8.5 N			0.1 N.m	0.1 N.m
	For positive opening				35 N				12.5 N			42.5 N			0.5 N.m	-
Connection	PvR cable, length 30 cm															

(1) For use at -40 °C.
(2) Nitrile for indoor use.
(3) Value taken with actuation by moving part at 100 mm from the fixing.

Limit switches

XC Standard range

Miniature design, metal, XCMV

Complete units for mobile equipment

Dimensions

Switches with Deutsch DT04-4P connector

XCMV2115D44, XCMV2515D44

XCMV2110D44, XCMV2510D44

XCMV2102D44, XCMV2502D44

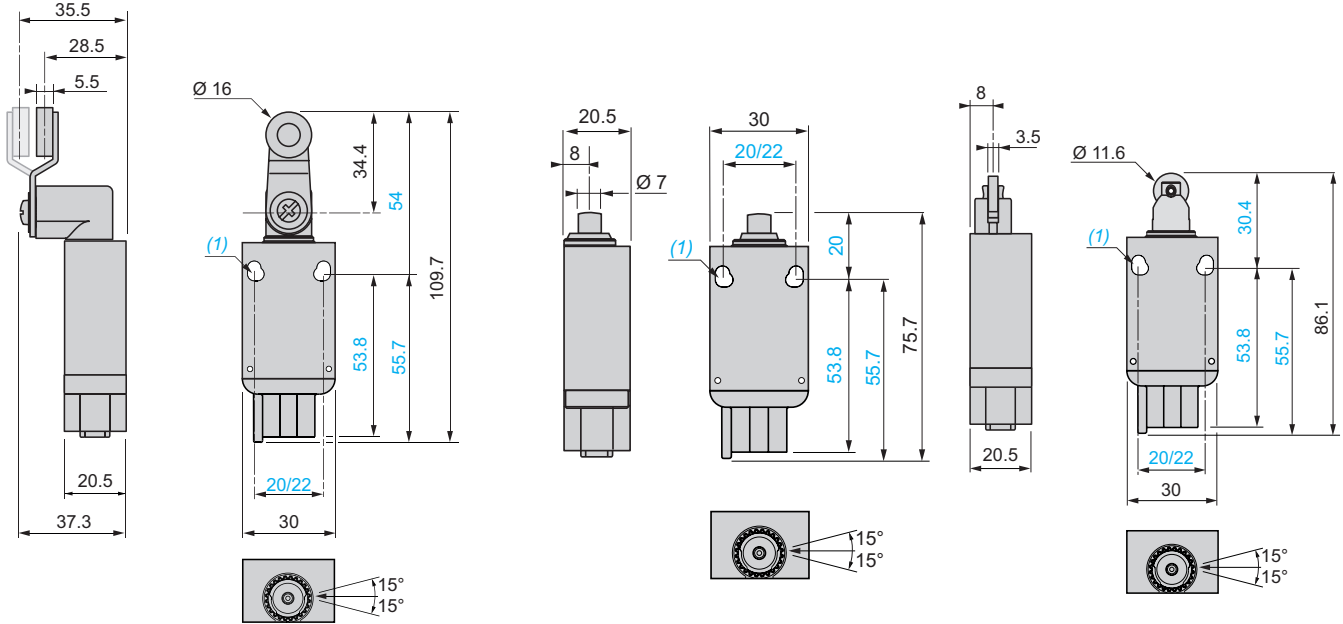

Switches with AMP Superseal 1.5 connector

XCMD2115AM4, XCMD2515AM4

XCMD2110AM4, XCMD2510AM4

XCMD2102AM4, XCMD2502AM4

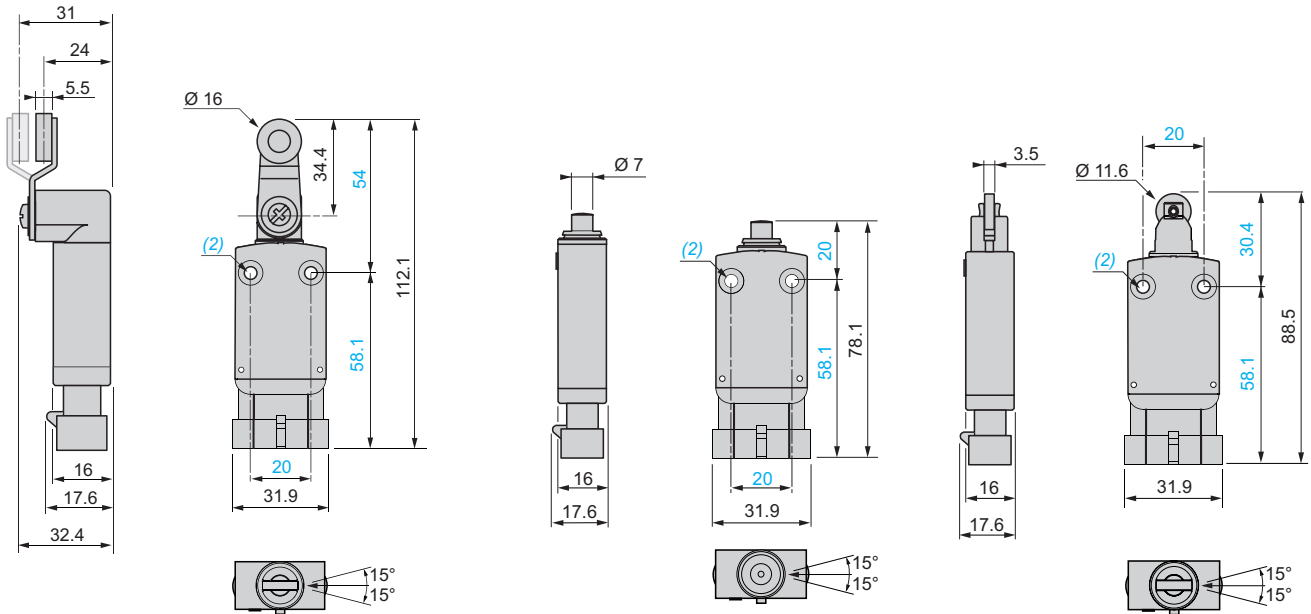

(1) 2 elongated fixing holes $\varnothing 4.3 \times 6.3$ mm on 22 mm centres, 2 elongated fixing holes $\varnothing 4.3$ on 20 mm centres.
 (2) 2 fixing holes $\varnothing 4.2$ mm, counterbored $\varnothing 8$ mm by 4 mm deep.

Dimensions (continued)

Switches with M12 connector

XCMV2115M12, XCMV2515M12

XCMV2110M12, XCMV2510M12

XCMV2102M12, XCMV2502M12

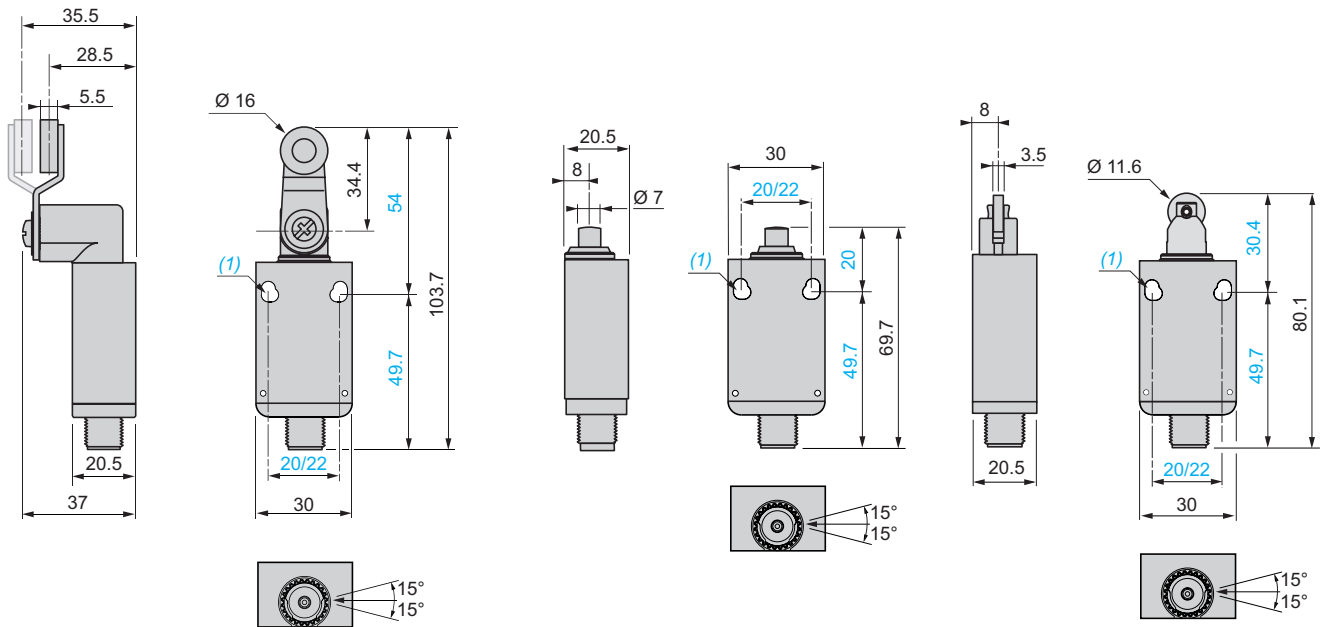

(1) 2 elongated fixing holes $\varnothing 4.3 \times 6.3$ mm on 22 mm centres, 2 elongated fixing holes $\varnothing 4.3$ on 20 mm centres.

Connections

Male AMP Superseal 1.5 connector

XCMV2●●●AM4



Male Deutsch DT04-4P connector

XCMV2●●●D44

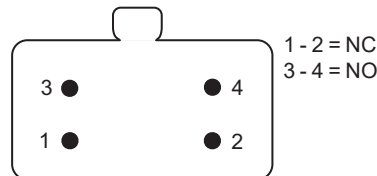

Male M12 connector

XCMV2●●●M12

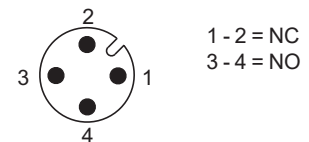

Limit switches

XC Standard range

Miniature design, metal, XCMV

Modular units for mobile equipment

Dimensions of bodies

ZCMV2•D44

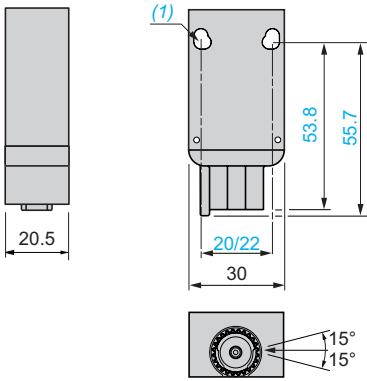

ZCMD2•AM4

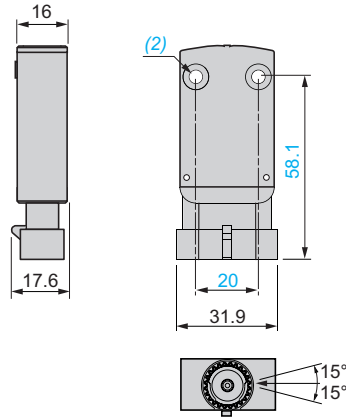

ZCMV2•M12

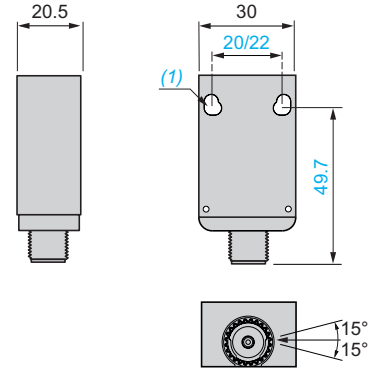

ZCMV41L03

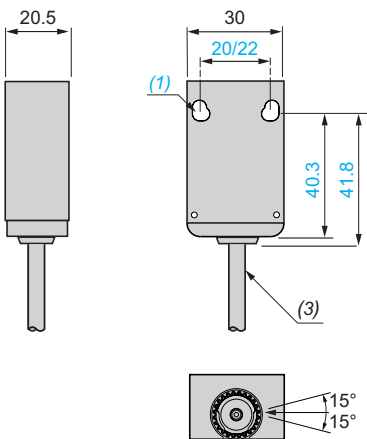

Mounting: distance required for connection

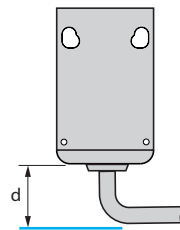

d: min. 20 mm

Dimensions of heads

ZCE106, ZCE10

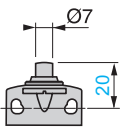

ZCE11

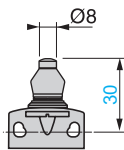

ZCE02, ZCE026

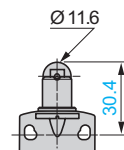

ZCE24

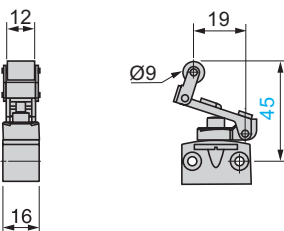

(1) 2 elongated fixing holes Ø 4.3 x 6.3 mm on 22 mm centres, 2 elongated fixing holes Ø 4.3 on 20 mm centres.

(2) 2 fixing holes Ø 4.2 mm, counterbored Ø 8 mm by 4 mm deep.

(3) External diameter of cable 6.4 mm.

Limit switches

XC Standard range

Miniature design, metal, XCMV

Modular units for mobile equipment

Dimensions of heads (continued)

ZCEF0

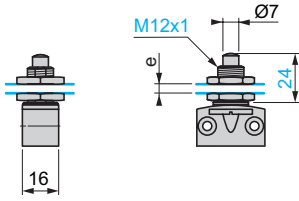

ZCEG1

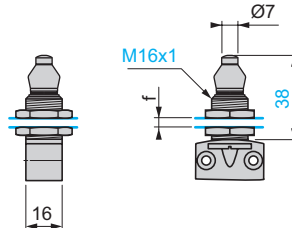

ZCEF2

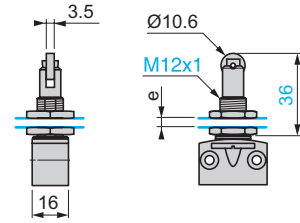

ZCE01 + ZCY15, ZCE01 + ZCY16
or ZCE01 + ZCY17

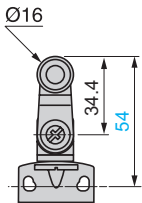

ZCE01 + ZCY45

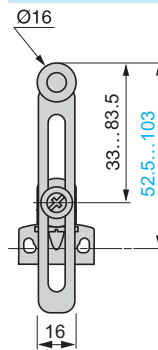

ZCE06

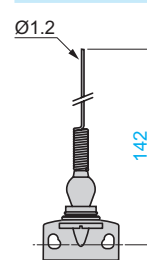

e: 8 mm max., panel cut-out Ø 12.5 mm, fixing nut thickness 3.5 mm.
f: 8 mm max., panel cut-out Ø 16.5 mm, fixing nut thickness 3.5 mm.