

Limit switches

XC Basic range

Miniature design, plastic, XCMH

Pre-cabled

Complete units pre-cabled

□ With head for linear movement (plunger), lateral or axial cable output



Pages 70 et 71

□ With head for rotary movement (lever), lateral or axial cable output



Page 71

□ With head for multi-directional movement, lateral cable output



Page 72

Environment characteristics		
Conformity to standards	Products	CE, IEC 60947-5-1, EN 60947-5-1, UL 508, CSA C22-2 n° 14
	Machine assemblies	IEC 60204-1, EN 60204-1
Product certifications		UL, cULus, UKCA
Protective treatment	Standard version	"TC"
Ambient air temperature	For operation	- 25...+ 70 °C
	For storage	- 40...+ 70 °C
Vibration resistance	Conforming to IEC 60068-2-6	5 gn (10...500 Hz)
Shock resistance	Conforming to IEC 60068-2-27	25 gn (18 ms)
Electric shock protection		Class II conforming to IEC 61140 and NF C 20-030
Degree of protection		IP 66, IP67 conforming to IEC 60529 IK 04 conforming to IEC 50102
Materials	Bodies	Plastic
	Heads	Zamak
Contact block characteristics		
Rated operational characteristics		~ AC-15 ; C300 (Ue = 240 V, Ie = 0.75 A) ; Ith = 3 A
		≡ DC-13 ; R300 (Ue = 250 V, Ie = 0.1 A), conforming to IEC 60947-5-1 Appendix C, EN 60947-5-1
Rated insulation voltage		Ui = 300 V degree of pollution 3 conforming to IEC 60947-1 Ui = 300 V conforming to UL 508, CSA C22-2 n° 14
Rated impulse withstand voltage		U imp = 4 kV conforming to IEC 60947-1, IEC 60664
Short-circuit protection		6 A cartridge fuse type gG (gl)

Limit switches

XC Basic range

Miniature design, plastic, XCMH

Pre-cabled

Type of head **Plunger (fixing by the body)**



Type of operator	Metal end plunger		Metal end plunger with silicone boot (1)	Steel roller plunger for lateral cam approach		Steel roller plunger for traverse cam approach	Thermoplastic roller lever plunger, horizontal actuation in 1 direction
Cable output	Lateral	Axial	Lateral	Lateral	Axial	Lateral	Lateral

References

<p>2-pole NC + NO snap action</p>	<p>XCMH2110L1</p> <p>XCMH2110L2</p> <p>XCMH2110L3</p>	<p>XCMH2110LA1</p>	<p>XCMH211AL05</p> <p>XCMH211AL1</p>	<p>XCMH2102L1</p> <p>XCMH2102L2</p> <p>XCMH2102L3</p> <p>XCMH2102L5</p> <p>XCMH2102L6</p> <p>XCMH2102L7</p> <p>XCMH2102L8</p> <p>XCMH2102L9</p>	<p>XCMH2102LA1</p>	<p>XCMH2103L1</p> <p>XCMH2103L2</p> <p>XCMH2103L3</p> <p>XCMH2103L5</p> <p>XCMH2103L8</p>	<p>XCMH2121L1</p> <p>XCMH2121L2</p> <p>XCMH2121L5</p>	
	<p>XCMH2910L1</p> <p>XCMH2910L2</p> <p>XCMH2910L3</p>	<p>XCMH2902L1</p> <p>XCMH2902L5</p>	<p>XCMH2903L1</p>					
Weight (kg)	0.5 m cable (L05)	0.064	0.064	0.055	0.070	0.070	0.070	0.077
1 m cable (L1)	0.064	0.064	0.069	0.070	0.070	0.070	0.070	0.077
2 m cable (L2)	0.092	0.092	0.092	0.099	0.099	0.099	0.099	0.106
3 m cable (L3)	0.120	0.120	0.120	0.127	0.127	0.127	0.127	0.134
5 m cable (L5)	0.184	0.184	0.184	0.184	0.184	0.184	0.184	0.191
6 m cable (L6)	0.212	0.212	0.212	0.212	0.212	0.212	0.212	0.219
7 m cable (L7)	0.240	0.240	0.240	0.240	0.240	0.240	0.240	0.247
8 m cable (L8)	0.269	0.269	0.269	0.269	0.269	0.269	0.269	0.276
9 m cable (L9)	0.297	0.297	0.297	0.297	0.297	0.297	0.297	0.304

Contact operation closed (A) = cam displacement NC contact with positive opening operation
 open (P) = positive opening point

Complementary characteristics not shown under general characteristics (see page 69)

Switch actuation	On end	By 30° cam
Type of actuation		
Maximum actuation speed	0.5 m/s	1.5 m/s
Mechanical durability	5 million operating cycles	
Minimum force or torque	For tripping	8.5 N.m
	For positive opening	42.5 N.m
Cabling	PvR cable, 4 x 0.34 mm ²	

(1) Silicone boot for outdoor use.

▲ Available 2nd semester 2023.

Limit switches

XC Basic range
Miniature design, plastic, XCMH
Pre-cabled

Type of head	Plunger (fixing by the body)	Plunger (fixing by the head)	Rotary (fixing by the body)			
--------------	------------------------------	------------------------------	-----------------------------	--	--	--



Type of operator	Thermoplastic roller lever plunger, horizontal actuation in 1 direction Head oriented at 270°	M12 with metal end plunger	M12 with steel roller plunger for lateral cam approach	Thermoplastic roller lever		Thermoplastic roller lever Head oriented at 180°
Cable output	Lateral	Lateral	Lateral	Lateral	Axial	Lateral

References

2-pole NC + NO snap action	XCMH2121L1R0	XCMH21F0L1	XCMH21F2L1	XCMH2115L1	XCMH2115LA1 ▲	XCMH2115L1L0
		⊖	⊖	⊖	⊖	⊖
		XCMH21F0L2	XCMH21F2L2	XCMH2115L2		XCMH2115L2L0
		⊖	⊖	⊖		⊖
				XCMH2115L3		XCMH2115L3L0
				⊖		⊖
				XCMH2115L8		
				⊖		
Weight (kg)	1 m cable (L1) 0.077 2 m cable (L2) – 3 m cable (L3) – 8 m cable (L8) –	0.081 0.110	0.091 0.120	0.106 0.134 0.163 0.304	0.106 – – –	0.106 0.134 0.163 –

Contact operation closed (A) = cam displacement NC contact with positive opening operation
 open (P) = positive opening point

Complementary characteristics not shown under general characteristics (see page 69)

Switch actuation	By 30° cam	On end	By 30° cam°		
Type of actuation					
Maximum actuation speed	0.5 m/s	0.5 m/s	0.1 m/s	0.1 m/s	1.5 m/s
Mechanical durability	5 million operating cycles				
Minimum force or torque	For tripping	2.5 N.m	8.5 N.m	7 N.m	0.1 N.m
	For positive opening	12.5 N.m	42.5 N.m	35 N.m	0.5 N.m
Cabling	PvR cable, 4 x 0.34 mm ²				





▲ Available 2nd semester 2023.

Limit switches

XC Basic range



Miniature design, plastic, XCMH

Pre-cabled

Type of head	Rotary (fixing by the body)	Multi-directional
		
		

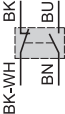
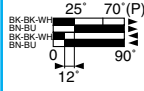
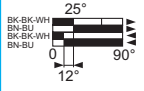
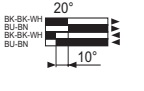
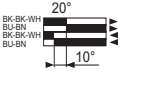
Type of operator	Variable length thermoplastic roller lever	Round thermoplastic rod lever, Ø 6 mm (1)	Spring lever with thermoplastic rod lever (1)	"Cat's whisker" (1)
Cable output	Lateral	Lateral	Lateral	Lateral

References					
	2-pole NC + NO snap action	XCMH2145L1	XCMH2159L1	XCMH2107L1	XCMH2106L1
		XCMH2145L2	XCMH2159L2	XCMH2107L2	XCMH2106L2
				XCMH2107L3	
					
Weight (kg)	1 m cable (L1)	0.115	0.070	0.079	0.068
	2 m cable (L2)	0.144	0.099	0.107	0.096
	3 m cable (L3)	–	–	0.136	–

Contact operation  closed  open (A) = cam displacement (P) = positive opening point ⊕ NC contact with positive opening operation

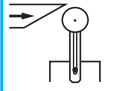
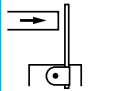
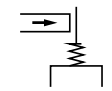
Complementary characteristics not shown under general characteristics (see page 69)				
Switch actuation		By 30° cam	By any moving part	
Type of actuation				
Maximum actuation speed		1.5 m/s	1 m/s	1 m/s (any direction)
Mechanical durability		5 million operating cycles		
Minimum force or torque	For tripping	0.1 N.m	0.1 N.m	0.1 N.m
	For positive opening	0.5 N.m	–	–
Cabling		PvR cable, 4 x 0.34 mm ²		

(1) Value taken with actuation by moving part at 100 mm from the fixing.

Limit switches

XC Basic range

Miniature design, plastic, XCMH

Pre-cabled

Dimensions

**XCMH2110L1, XCMH2110L2, XCMH2110L3,
XCMH2910L1, XCMH2910L2 and XCMH2910L3**

XCMH2110LA1

XCMH211AL05 and XCMH211AL1

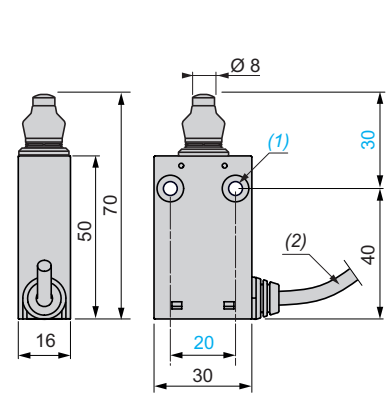
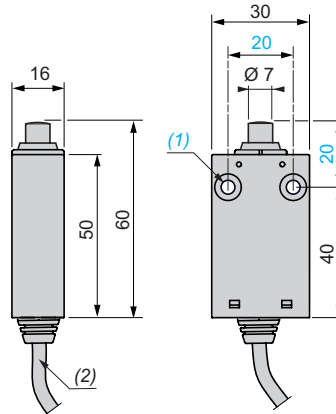
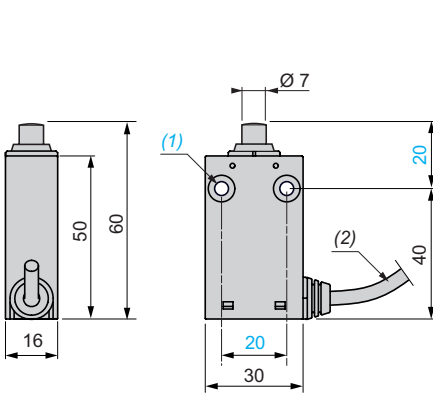

**XCMH2102L1, XCMH2102L2, XCMH2102L3,
XCMH2102L5, XCMH2102L6, XCMH2102L7,
XCMH2102L8, XCMH2102L9, XCMH2902L1
and XCMH2902L5**

XCMH2102LA1

**XCMH2103L1, XCMH2103L2,
XCMH2103L3, XCMH2103L5
and XCMH2103L8**

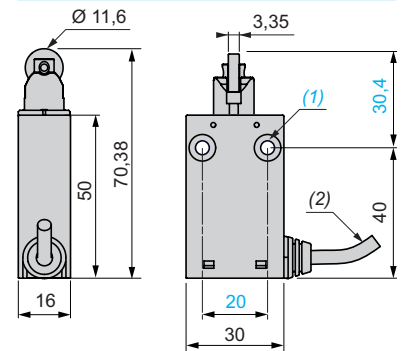
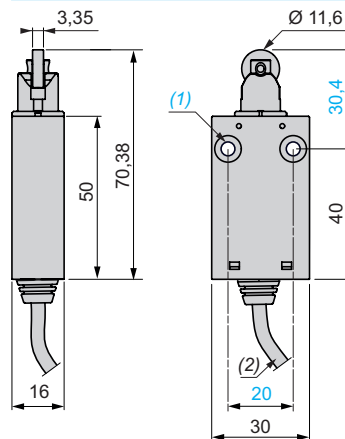
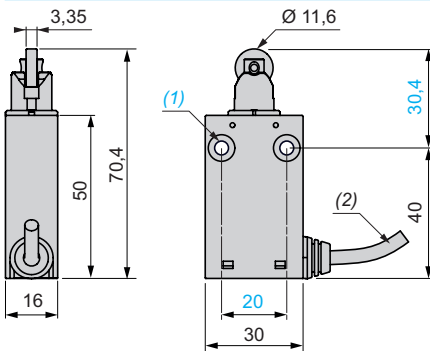

XCMH2121L1, XCMH2121L2 and XCMH2121L5

XCMH2121L1R0

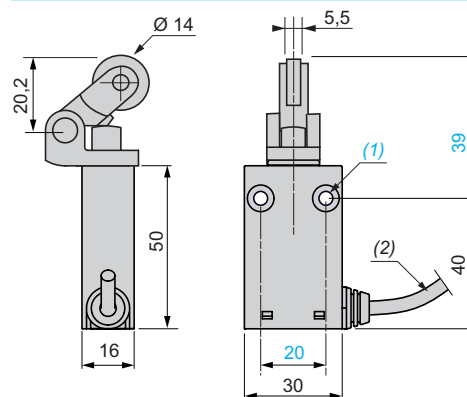
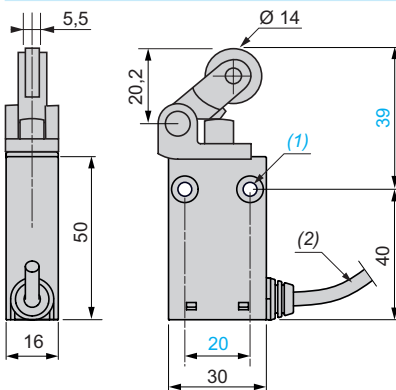

(1) 2 fixing holes Ø 4.2 mm, counterbored Ø 8 mm by 4 mm deep.

(2) External diameter 4.2 mm.

Limit switches

XC Basic range

Miniature design, plastic, XCMH

Pre-cabled

Dimensions (continued)

XCMH21F0L1 and XCMH21F0L2

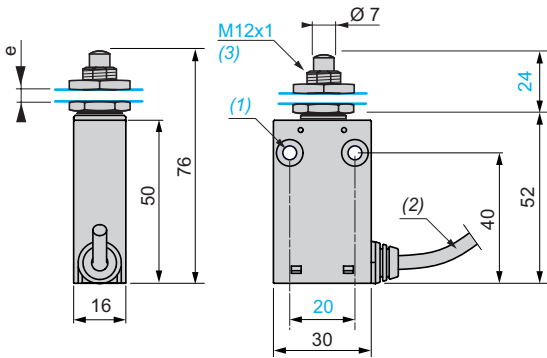

XCMH21F2L1 and XCMH21F2L2

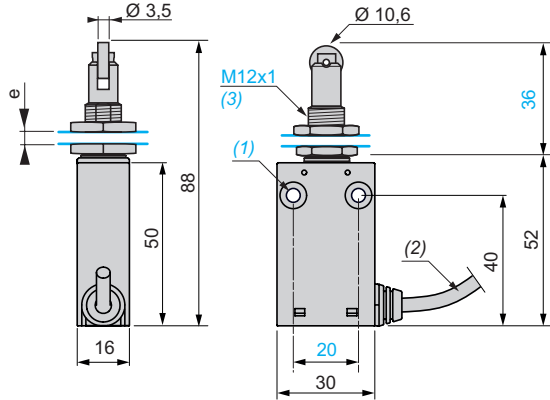

e: 8 mm max, panel cut-out Ø 12.5 mm. Fixing nut thickness 3.5 mm.

e: 8 mm max, panel cut-out Ø 12.5 mm. Fixing nut thickness 3.5 mm.

XCMH2115L1, XCMH2115L2, XCMH2115L5 and XCMH2115L8

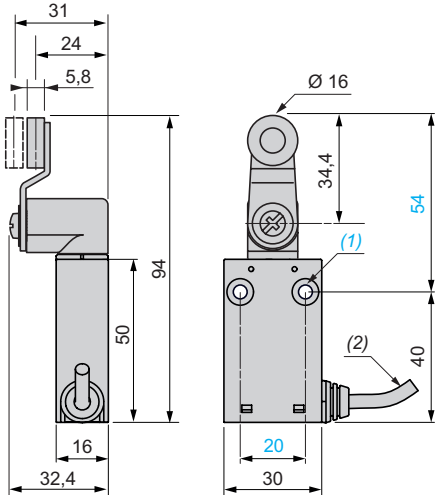

XCMH2115LA1

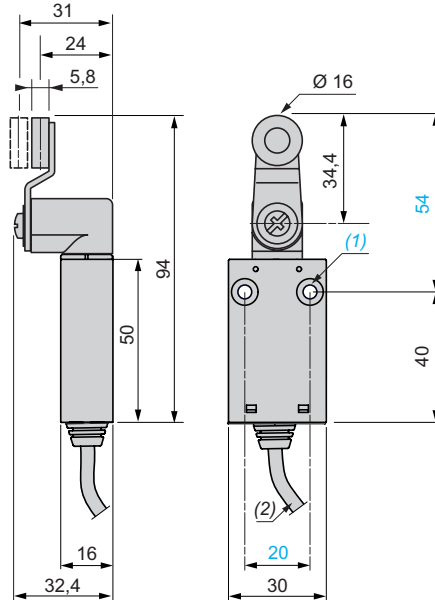

XCMH2115L1L0, XCMH2115L2L0 and XCMH2115L3L0

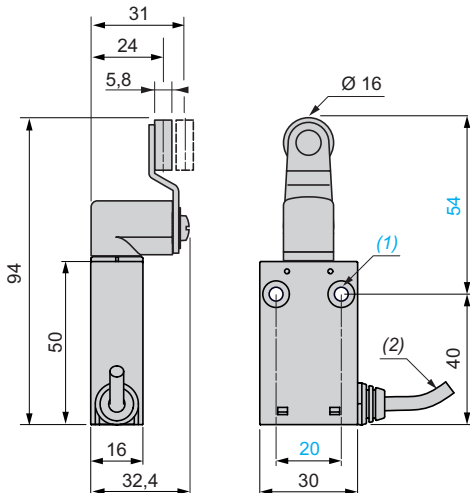

(1) 2 fixing holes Ø 4.2 mm, counterbored Ø 8 mm by 4 mm deep.

(2) External diameter 4.2 mm.

(3) Fixing nut thickness 3.5 mm.

Limit switches

XC Basic range

Miniature design, plastic, XCMH

Pre-cabled

Dimensions (continued)

XCMH2145L1 and XCMH2145L2

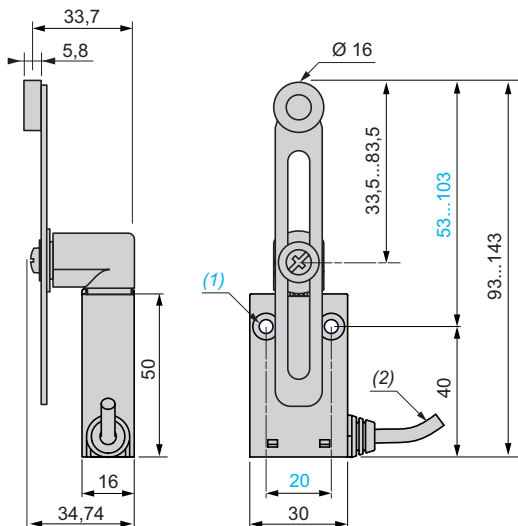

XCMH2159L1 and XCMH2159L2

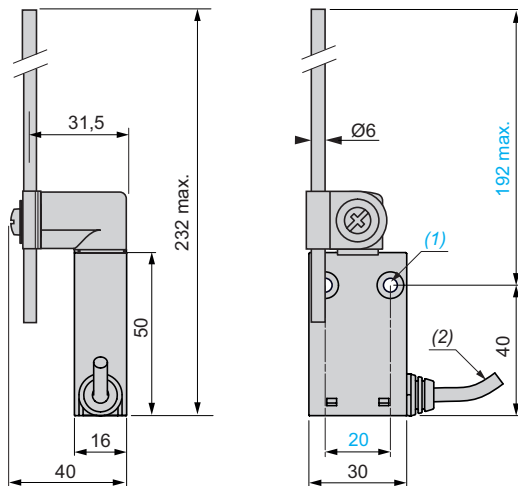

XCMH2107L1, XCMH2107L2 and XCMH2107L3

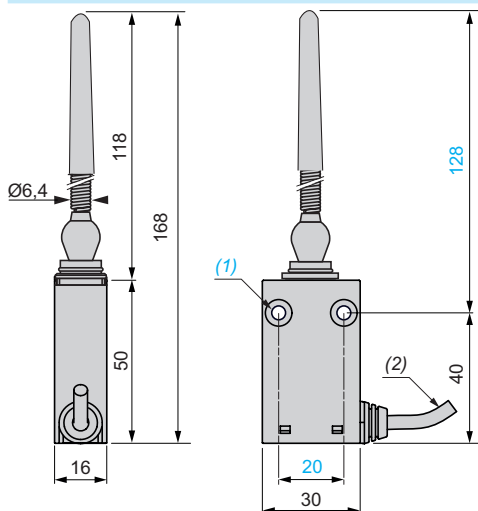

XCMH2106L1 and XCMH2106L2

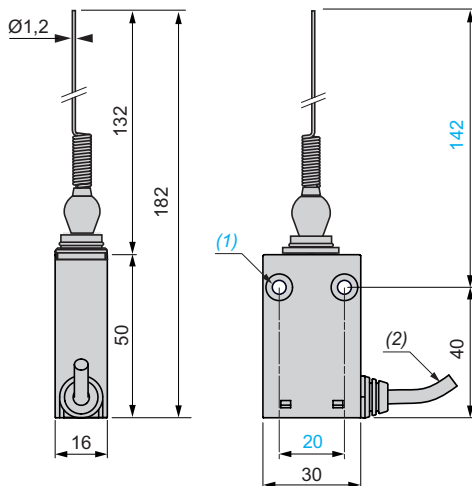

Mounting: distance required for connection

Limit switches with cable lateral output

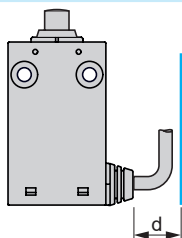

Limit switches with cable axial output

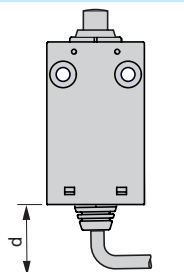

d: min. 15 mm.

(1) 2 fixing holes Ø 4.2 mm, counterbored Ø 8 mm by 4 mm deep.

(2) External diameter 4.2 mm.