

### Introduction

A3/2

### TeSys Hybrid motor starters

Type of product	Range		Page
<p><b>Ultra-compact starters IEC ratings</b> Standard starters, screw or spring terminals, direct-on-line or reverse</p> <p>Safety starters, screw or spring terminals, direct-on-line or reverse</p>	<p>Up to <b>3 kW</b> AC53a Up to <b>9 A</b> AC51</p>		A3/6
<p><b>Ultra-compact starters UL ratings</b> Standard starters, screw or spring terminals, direct-on-line or reverse</p> <p>Safety starters, screw or spring terminals, direct-on-line or reverse</p>	<p>Up to <b>3 hp</b> AC53a Up to <b>9 A</b> AC51</p>		A3/7
<p>TeSys Deca Circuit breakers for a group of starters Selection of magnetic motor circuit breakers TeSys GV2L – rotary knob TeSys GV2LE – rocker lever</p>	<p>Up to <b>32 A</b></p>		A3/8

Hybrid  
motor  
starters

### Technical Data for Designers

A3/11

# The most compact 3 KW / 400 V starter in the world

Hybrid motor starters



## Up to 75 % of space reduction

- Ultra-compact 22.5 mm starter
- Reversing starter in the same width
- Maximum space savings for group starter architecture

## Long electrical durability

- Suitable for high demanding application
- 30 000 000 of AC53a electrical cycles

> With printed QR code, referring directly to the product data sheet.

## Easy Design

- Wide range setting motor protection
- Automatic, manual or remote reset after thermal trip
- Wide range of control voltage

## Easy to integrate

- Direct mounting installation on DIN rail
- Control terminals on the upper side
- Power terminal on the lower side

## Standard version

- 2 ratings:
  - 2.4 A 400 V AC53a
  - 6.5 A 400 V AC53a
- 2 control voltages:
  - 24 V DC
  - 110 V / 230 V AC
- 2 terminal types:
  - Screw clamps
  - Spring
- Can provide up to 3 functions:
  - Forward running
  - Reverse running
  - Overload protection



Hybrid motor starters



## Safety version

- Safe Torque Off embedded:
  - SIL3 according to IEC61508-1
  - PlE according to ISO13849-1
- ATEX:
  - As associated devices for motor protection

> Hybrid motor starters are a solution dedicated to low footprint applications, in industries as food and beverage, logistics, and durable goods.



Hybrid motor starters

Conventional ..... OR ..... Hybrid Standard starter



Direct-on-line



Reverse



> How does the hybrid technology work ?

**Hybrid technology:**  
Each contact is coupled with a power semiconductor for switching  
  
> Higher number of on/off switches, extended durability.

> Closing

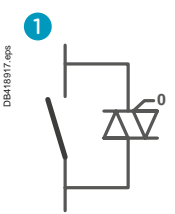

**Start:** conduction through the semiconductor.

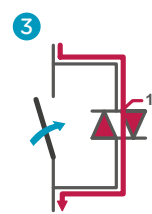

Contact closure under zero voltage. No electrical arc: the contact is preserved.

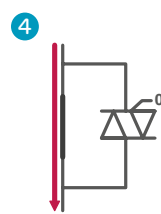

The semiconductor is non-conducting.

> Opening

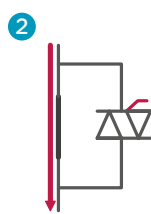
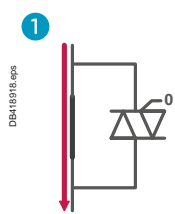

Before the opening of the contact the semiconductor is triggered.



Contact opening: - no arc: the contact is preserved.

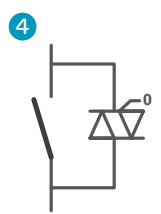

**Stop:** the semiconductor becomes non-conducting.

Conventional ..... OR ..... Hybrid Safety starter

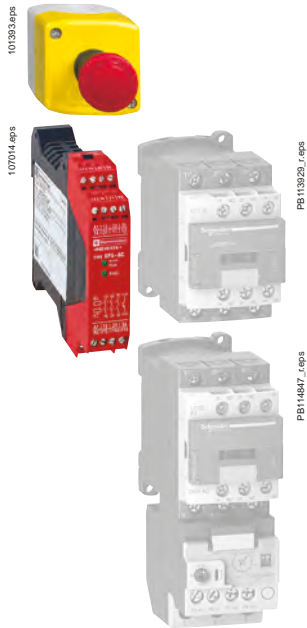

Direct-on-line



Hybrid motor starters

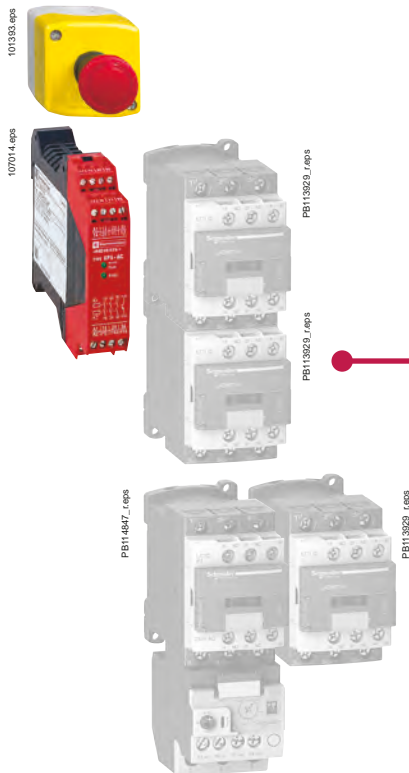

Reverse



Hybrid Safety starter

- Immediate respect of the highest safety standards
- Simplified design of your safety electrical architecture
- Quicker panel implementation

# TeSys Control

## DOL/Reverser, Standard/Safety Hybrid starters

### Product references (per IEC ratings)

PB114711.eps



LZ1H2X4BD

Hybrid motor starters

### Starters for asynchronous motors - AC53a utilization category:

#### Standard starters hybrid per IEC ratings

Starters	3- phases motor: max power (KW) for various voltage							Current range	Commercial references <sup>(1)</sup>
	220 V	230 V	380 V	400 V	415 V	440 V	500 V		
<b>Direct-on-line</b>									
Screw terminals	0.37	0.37	0.75	0.75	0.75	0.75	1.1	0.18...2.4	LZ1H2X4●●
	1.5	1.5	2.2	3	3	3	3	1.5...6.5	LZ1H6X5●●
Spring terminals	0.37	0.37	0.75	0.75	0.75	0.75	1.1	0.18...2.4	LZ1H2X43●●
	1.5	1.5	2.2	3	3	3	3	1.5...6.5	LZ1H6X53●●
<b>Reverse</b>									
Screw terminals	0.37	0.37	0.75	0.75	0.75	0.75	1.1	0.18...2.4	LZ2H2X4●●
	1.5	1.5	2.2	3	3	3	3	1.5...6.5	LZ2H6X5●●
Spring terminals	0.37	0.37	0.75	0.75	0.75	0.75	1.1	0.18...2.4	LZ2H2X43●●
	1.5	1.5	2.2	3	3	3	3	1.5...6.5	LZ2H6X53●●

(1) Replace the ●● in the reference by the bobine code: BD (24 V DC) or FU (110-230 V AC).

PB114715.eps



LZ7H2X4BD



#### Safety starters hybrid per IEC ratings

Starters	3- phases motor: max power (KW) for different tensions							Current range	Commercial references <sup>(1)</sup>
	220 V	230 V	380 V	400 V	415 V	440 V	500 V		
<b>Direct-on-line</b>									
Screw terminals	0.37	0.37	0.75	0.75	0.75	0.75	1.1	0.18...2.4	LZ7H2X4●●
	1.5	1.5	2.2	3	3	3	3	1.5...6.5	LZ7H6X5●●
Spring terminals	0.37	0.37	0.75	0.75	0.75	0.75	1.1	0.18...2.4	LZ7H2X43●●
	1.5	1.5	2.2	3	3	3	3	1.5...6.5	LZ7H6X53●●
<b>Reverse</b>									
Screw terminals	0.37	0.37	0.75	0.75	0.75	0.75	1.1	0.18...2.4	LZ8H2X4●●
	1.5	1.5	2.2	3	3	3	3	1.5...6.5	LZ8H6X5●●
Spring terminals	0.37	0.37	0.75	0.75	0.75	0.75	1.1	0.18...2.4	LZ8H2X43●●
	1.5	1.5	2.2	3	3	3	3	1.5...6.5	LZ8H6X53●●

(1) Replace the ●● in the reference by the bobine code: BD (24 V DC) or FU (110-230 V AC).

### Starters for resistive load AC51 utilization category:

Starters	Resistive load current A	Application	Commercial references <sup>(1)</sup>
		Safety	LZ7H2X4●●
	9	Standard	LZ1H6X5●●
		Safety	LZ7H6X5●●
Spring terminals	2.4	Standard	LZ1H2X43●●
		Safety	LZ7H2X43●●
	9	Standard	LZ1H6X53●●
		Safety	LZ7H6X53●●

(1) Replace the ●● in the reference by the bobine code: BD (24 V DC) or FU (110-230 V AC).

# TeSys Control

## DOL/Reverser, Standard/Safety Hybrid starters

Product references (per UL ratings)

PB114713.eps



LZ1H2X43BD

### Starters for asynchronous motors - AC53a utilization category:

#### Standard starters hybrid per UL ratings

Starters	3- phases motor in HP			Current range A	Commercial references <sup>(1)</sup>
	208 V	220 V - 240 V	440 V - 480 V		
<b>Direct-on-line</b>					
Screw terminals	1/2	1/2	1	0.18...2.4	LZ1H2X4●●
	1	1.5	3	1.5...6.5	LZ1H6X5●●
Spring terminals	1/2	1/2	1	0.18...2.4	LZ1H2X43●●
	1	1.5	3	1.5...6.5	LZ1H6X53●●
<b>Reverse</b>					
Screw terminals	1/2	1/2	1	0.18...2.4	LZ2H2X4●●
	1	1.5	3	1.5...6.5	LZ2H6X5●●
Spring terminals	1/2	1/2	1	0.18...2.4	LZ2H2X43●●
	1	1.5	3	1.5...6.5	LZ2H6X53●●

(1) Replace the ●● in the reference by the bobine code: BD (24 V DC) or FU (110-230 V AC).

Hybrid motor starters

PB114716.eps



LZ8H6X5BD

#### Safety starters hybrid per UL ratings

Starters	3- phases motor in HP			Current range A	Commercial references <sup>(1)</sup>
	208 V	220 V - 240 V	440 V - 480 V		
<b>Direct-on-line</b>					
Screw terminals	1/2	1/2	1	0.18...2.4	LZ7H2X4●●
	1	1.5	3	1.5...6.5	LZ7H6X5●●
Spring terminals	1/2	1/2	1	0.18...2.4	LZ7H2X43●●
	1	1.5	3	1.5...6.5	LZ7H6X53●●
<b>Reverse</b>					
Screw terminals	1/2	1/2	1	0.18...2.4	LZ8H2X4●●
	1	1.5	3	1.5...6.5	LZ8H6X5●●
Spring terminals	1/2	1/2	1	0.18...2.4	LZ8H2X43●●
	1	1.5	3	1.5...6.5	LZ8H6X53●●

(1) Replace the ●● in the reference by the bobine code: BD (24 V DC) or FU (110-230 V AC).



### Starters for resistive load AC51 utilization category:

Starters	Resistive load current	Application	Commercial references <sup>(1)</sup>
	A		
Screw terminals	2.4	Standard	LZ1H2X4●●
		Safety	LZ7H2X4●●
	9	Standard	LZ1H6X5●●
		Safety	LZ7H6X5●●
Spring terminals	2.4	Standard	LZ1H2X43●●
		Safety	LZ7H2X43●●
	9	Standard	LZ1H6X53●●
		Safety	LZ7H6X53●●

(1) Replace the ●● in the reference by the bobine code: BD (24 V DC) or FU (110-230 V AC).

# TeSys Control

## Deca Magnetic circuit breakers for group protection

### Selection table



GV2L + LZ2H2X4BD

- Magnetic motor circuit breakers:
- GV2L: rotary knob type - Ue = 500 V
  - GV2LE: rocker lever type - Ue = 415 V.

#### Selection of the circuit breaker Type 1 coordination according to IEC/EN 60947-4-2

Max A	Iq kA	Number of H		Reference Circuit breaker	
		2.4 A	6.5 A	Rotary	Rocker
0.4	50.0	1	–	GV2L03	GV2LE03
0.63	50.0	1	–	GV2L04	GV2LE04
1	50.0	1	1	GV2L05	GV2LE05
1.6	50.0	1	1	GV2L06	GV2LE06
2.5	35.0	1	1	GV2L07	GV2LE07
4	12.5	1	1	GV2L08	GV2LE08
6.3	8.0	2	1	GV2L10	GV2LE10
10	7.0	4	1	GV2L14	GV2LE14
14	5.0	5	2	GV2L16	GV2LE16
18	4.0	7	2	GV2L20	GV2LE20
25	4.0	10	3	GV2L22	GV2LE22
32	3.0	13	4	GV2L32	GV2LE32





# TeSys Control

## Hybrid motor starters

### Product references

LZ1H2X43BD	LZ7H2X43BD
LZ1H2X43FU	LZ7H2X43FU
LZ1H2X4BD	LZ7H2X4BD
LZ1H2X4FU	LZ7H2X4FU
LZ1H6X53BD	LZ7H6X53BD
LZ1H6X53FU	LZ7H6X53FU
LZ1H6X5BD	LZ7H6X5BD
LZ1H6X5FU	LZ7H6X5FU
LZ2H2X43BD	LZ8H2X43BD
LZ2H2X43FU	LZ8H2X43FU
LZ2H2X4BD	LZ8H2X4BD
LZ2H2X4FU	LZ8H2X4FU
LZ2H6X53BD	LZ8H6X53BD
LZ2H6X53FU	LZ8H6X53FU
LZ2H6X5BD	LZ8H6X5BD
LZ2H6X5FU	LZ8H6X5FU

Hybrid  
motor  
starters

This document is current.  Click on the product reference to get the most recent availability status (hyperlink to [se.com](https://www.se.com) product datasheet).  
If your product variant is no longer available, please consult your distributor or regional sales office.

# Technical Data for Designers

## Contents

Description .....	A3/12 to A3/13
Characteristics .....	A3/14 to A3/15
Curves .....	A3/16 to A3/17
Dimensions and schemes .....	A3/18

## Identification of terminals / Indicators / Setting means and procedure

### Setting procedure

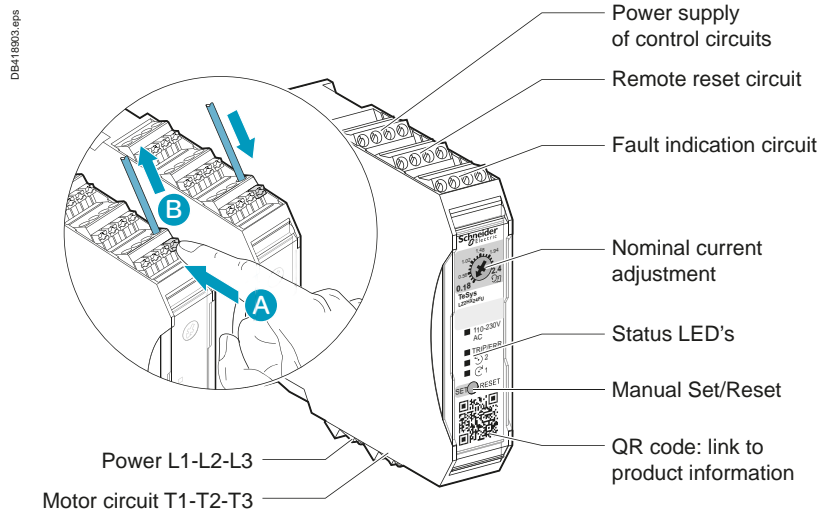

STEP	ACTION
1	Lift the cover on the front of the Hybrid motor starter to access the SET/RESET button.
2	Press and hold down the SET/RESET button for at least 6 seconds. After 6 seconds the 110-230 V AC or 24 V DC LED flashes once.
3	After the LED has flashed once, release the SET/RESET button.
4	Turn the potentiometer to select a nominal current, and then fine-tune the position until the LEDs indicate the exact nominal current.
5	Press the SET/RESET button to save the selected nominal current. The 110-230 V AC or 24 V DC LED comes on and the other LEDs go off.
6	Drop the cover back over the front of the Hybrid motor starter.

## Protection functions

### The protection of three - phase motors is ensured against potential faults

- Thermal overload: the motor currents exceed the set value.
- Phase unbalanced: the motor currents differ from each other by more than 33 %
- Phase loss: power missing on one or several phases
- Stall and jam: motor current exceeding 45 A for more that 2 s during starting or running phase - No motor is connected - Motor current is lower that the minimum configurable current for more than 2 seconds, on at least two phases.

For all this detected situations, the Hybrid motor starter will switch off, activate its TRP/ERR LED and fault signaling contact.

Please refer to the "Instruction sheet and User Guide" for more information.



# TeSys Control

## Hybrid motor starters

### Characteristics

Hybrid motor starters

- Ref.
- i
- 
- 
- 

Environment			
Rated insulation voltage (Ui)	Conforming to IEC/EN 60947-1, overvoltage category III, degree of pollution: 2	V	500
Rated impulse withstand voltage (Uimp)	Conforming to IEC/EN 60947-4-2	kV	6 (24 V DC control voltage); 4 (110 V - 230 V AC control voltage)
Conforming to standards			IEC / EN 60947-4-2
Product certifications			CE, CUL, ATEX ( for failsafe product), CCC, UKCA
Degree of protection	Conforming to IEC / EN 60947-1		IP20
Environment category	Conforming to IEC / EN 60947-1		E
Climatic withstand			Conforming to IEC/EN 60068-2-30
Ambient air temperature around the device	Storage	°C	-40...+80
	Operation (see derating curves)	°C	-25...+70
Maximum operating altitude	without derating	m	2000
	with derating	m	No
Operating positions (see derating curves)	Vertical axis (horizontal DIN rail)		Yes
	Horizontal axis (vertical DIN rail)		Not authorised
Shock resistance	Conforming to IEC/EN 60068-2-27	gn	30 Starter OFF
1/2 sine wave = 18 ms		gn	30 Starter ON
Vibration resistance	Conforming to IEC/EN 60068-2-6	gn	5 Starter OFF
10...150 Hz		gn	5 Starter ON
Resistance to electrostatic discharge	Conforming to IEC/EN 61000-4-2	kV	Air discharge: 8 kV
		kV	Contact discharge: 6 kV
Immunity to radiated high-frequency disturbance	Conforming to IEC/EN 61000-4-3		
	80 - 1 GHz	V/m	20
	1.0 - 6 GHz	V/m	10
Immunity to fast transient currents	Conforming to IEC/EN 61000-4-4	kV	3
Immunity to conducted high frequency disturbances	Conforming to IEC/EN 61000-4-6	V	10
Radiated emission and conducted	Conforming to CISPR 11 and EN 55011		Class A
Surge	Conforming to IEC/EN 61000-4-5	kV	1 symmetrical
		kV	2 asymmetrical
Control circuit characteristics			
Rated voltage	~ 50/60 Hz	V	110 - 230
	≡	V	24
Voltage limits	~ 50/60 Hz	V	85...253
	≡	V	19.2...30
Voltage dips		ms	3
Short time interruptions		ms	3
Power circuit characteristics			
			<b>LZ●2X4●●</b>
			<b>LZ●6X5●●</b>
Power dissipation for corresponding Rated Operating Current (see derating curve)		W	0.88 ... 4.1
Rated Operating Current	AC51 conforming to IEC/EN 60947-4-3	A	0.18 - 2.4
	AC53a conforming to IEC/EN 60947-4-2	A	0.18 - 2.4
Electrical life	AC51	Op	30 000 000 <sup>(1)</sup>
		Op	10 000 <sup>(2)</sup>
	AC53A	Op	30 000 000 <sup>(1)</sup>
		Op	10 000 <sup>(2)</sup>
Maximum Operating rate	AC51	Op/h	7200
	AC53A		See curves
Time to restart after overload trip	Manual or remote mode	mn	2
	Automatic	mn	20
Power and control terminal Characteristics			
	<b>Terminal type</b>		<b>Screw M3</b>
			<b>Push in</b>
Flexible cable without cable end	1 conductor	mm <sup>2</sup>	0.25...2.5
	2 conductors	mm <sup>2</sup>	0.25...0.75
Flexible cable with cable end	1 conductor	mm <sup>2</sup>	0.25...2.5
	2 conductors	mm <sup>2</sup>	0.25...1.5
Solid cable without cable end	1 conductor	mm <sup>2</sup>	0.25...2.5
	2 conductors	mm <sup>2</sup>	0.25...0.75
Screwdriver		mm	flat screwdriver: 3 mm
Tightening torque		N.m	0.5..0.6
<i>(1) With ON/OFF control through control inputs (I<sub>1</sub>, I<sub>2</sub> terminals) (2) With ON/OFF control through power supply (A<sub>1</sub>, A<sub>2</sub> terminals).</i>			
References: pages A3/6 and A3/7	Description: pages A3/12 and A3/13	Curves: pages A3/16 and A3/17	Dimensions, schemes: page A3/18

# TeSys Control

## Hybrid motor starters

### Characteristics

System conditons		
Database for failure rates		SN 29500
System type		Type B
Standard used		IEC 61508
Beta factor		1 %
Mean time to failure (MTTF) at an ambient temperature 40 °C		39.3 (LZ7H or LZ8H 24 V DC) 39.1 (LZ7H or LZ8H 110/230 V AC)

Safe torque-off			
		LZ7H or LZ8H 24 V DC	LZ7H or LZ8H 110/230 V AC
Ambient temperature	°C	40	40
Mean time to failure (MTTF)		517	289
Switch-off time		80	100
$\lambda_{sd}$ [FIT] safe, detectable		664	638
$\lambda_{su}$ [FIT] safe, undetectable		968	935
$\lambda_{dd}$ [FIT] dangerous, detectable		218	388
$\lambda_{du}$ [FIT] dangerous, undetectable		2.67	6.82
SFF [%] Safe failure fraction		99	99
DCS [%] Diagnostic coverage safe		40.7	40.6
DC [%] Diagnosctic coverage		98	98
PFH Probability of dangerous failure per hour		$2.67 \times 10^{-9}$	$6.82 \times 10^{-9}$
Safety level		IEC/CEI 61508-1: SIL 3 ISO 13849-1: Category 3 PL e EN 60954-1: Category 3	

Motor overload protection			
		LZ7H or LZ8H 24 V DC	LZ7H or LZ8H 110/230 V AC
Ambient temperature	°C	40	40
Mean time to failure (MTTF)		447	273
Time to trip		As for Class 10 A, IEC/CEI 60947-4-2	
$\lambda_{sd}$ [FIT] safe, detectable		637	636
$\lambda_{su}$ [FIT] safe, undetectable		870	841
$\lambda_{dd}$ [FIT] dangerous, detectable		239	402
$\lambda_{du}$ [FIT] dangerous, undetectable		17	17
SFF [%] Safe failure fraction		99	99
DCS [%] Diagnostic coverage safe		42.3	43.1
DC [%] Diagnosctic coverage		93	95
Safety level		IEC/CEI 61508-1: SIL 2	

#### Overload protection tripping curve at 20 °C

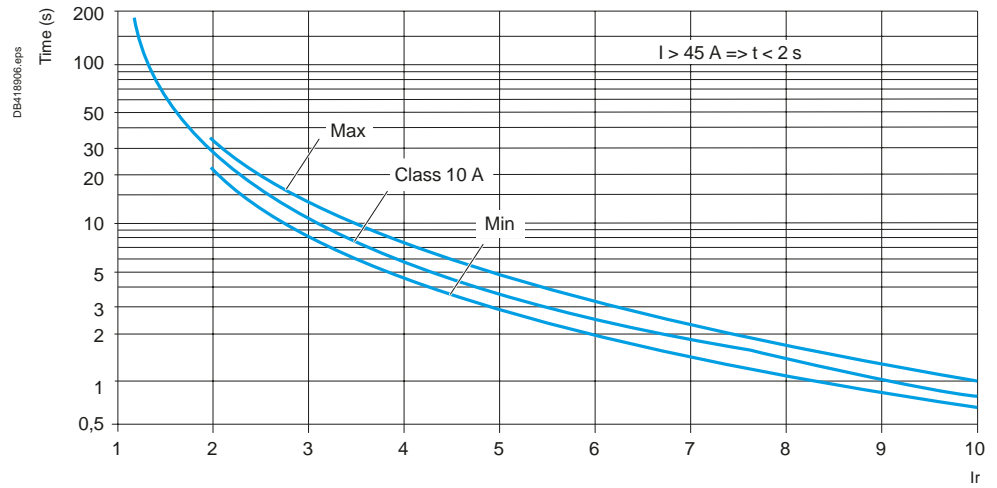

#### Derating curves: maximum load current (In)

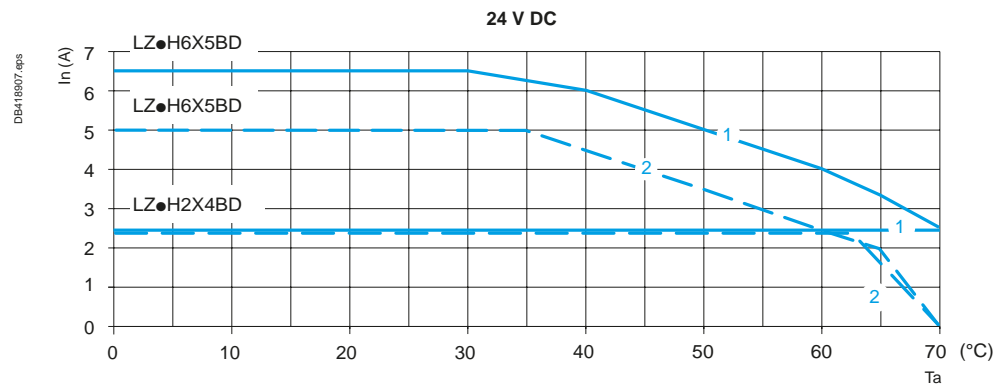

#### Derating according:

- motor starter control power supply
- ambient temperature ( $T_a$ )
- distance between devices **1**: 20 mm, with spacing  
**2**: without spacing.

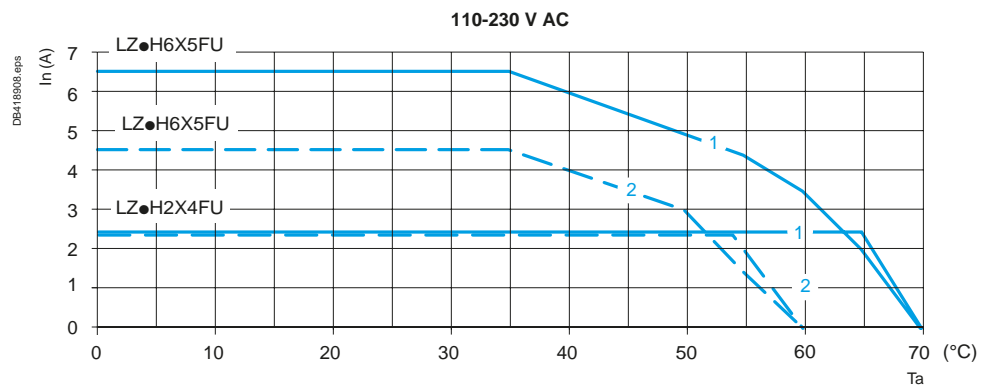



#### Minimum duty cycle $t/T$ (%) versus cycle duration $T$ (s)

Due to the effect of the peak current on the H monitoring circuit during the starting time, a stop/start sequence should not occur before a certain amount of time. The diagrams below show the minimum duty cycle according to the total period for 2 typical starting time values.

#### With a starting time = 100 ms

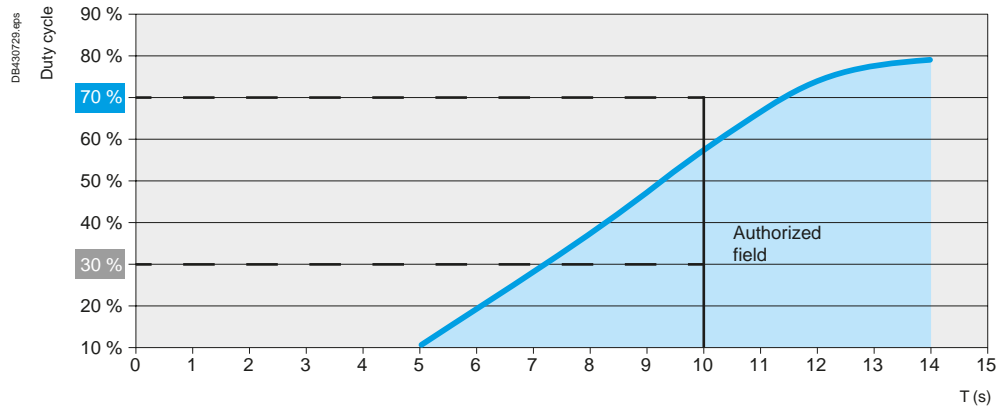

#### Example for starting time of 100 ms with period $T = 10$ s.

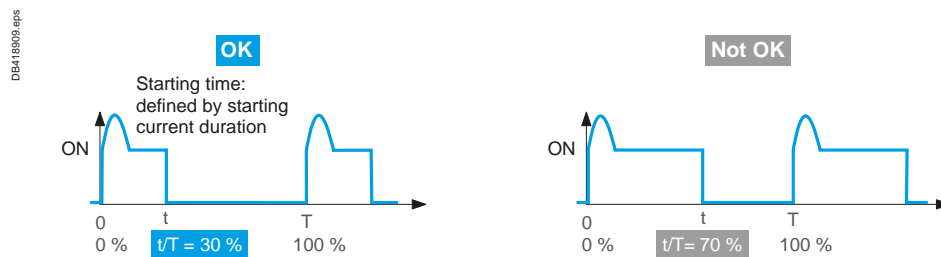

#### With a starting time = 150 ms

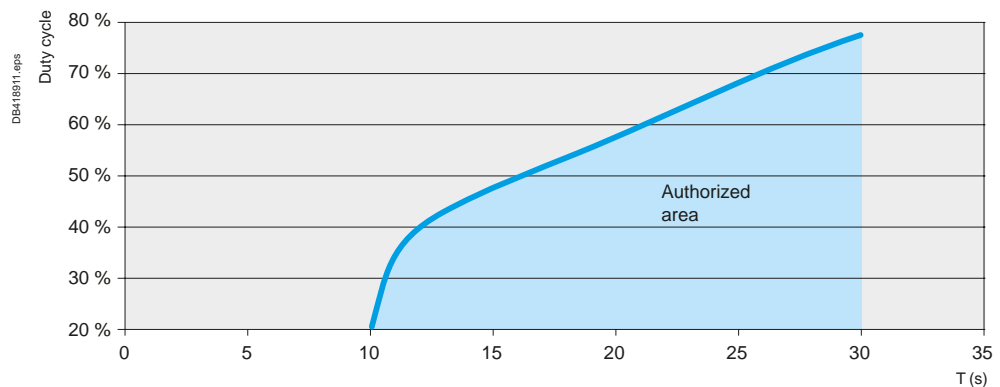

# TeSys Control

## Hybrid motor starters

### Dimensions, schemes

#### Dimensions mm

##### LZ●H●●●●●

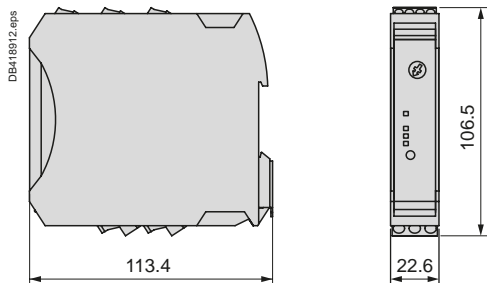

##### LZ●H●●●●3●●

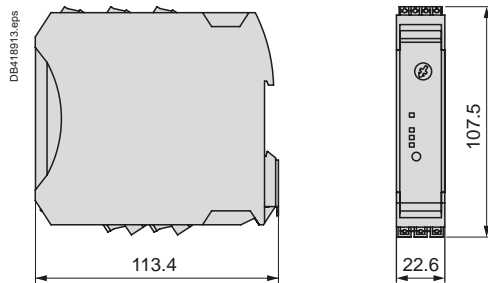

Hybrid motor starters

#### Wiring diagrams

##### Motor control by standard starter

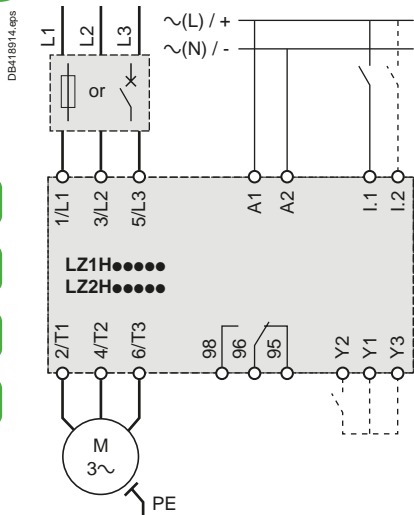

##### Motor control by safety starter

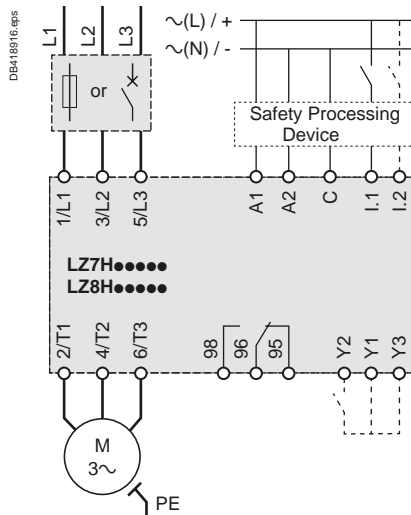

#### Power terminals

T1, T2, T3 Motor connection  
L1, L2, L3 Power inputs

#### Control terminals

A1, A2 Auxiliary power unit  
I.1 Control input, direction 1  
I.2 Control input, direction 2  
(LZ2H and LZ8H only)  
C Control inputs common point  
(LZ7H and LZ8H only)  
Y1 Reset mode, common point  
Y2 Reset mode, remote, manual  
Y3 Reset mode, automatic  
98, 96, 95 Trip or error signaling contact