

DATA SHEET

TM 210-R



Temperature transmitter



Possibility of a second remote probe on terminal block



**4 wires analogue outputs
0-5/10 V or 0/4-20 mA**



2 relay outputs



**ABS V0 IP65 housing,
with display**

Features

- Configurable ranges from 0 to 50°C (ambient model) and from -100 to 400°C (model with terminal block)
- 24 Vdc/Vac power supply
- Display of the minimum and maximum values and trend indicator
- "¼ turn" system mounting with wall-mount plate

Part number

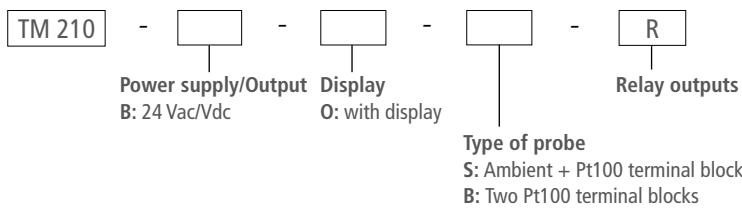

Example: TM210 – BOS – R
Temperature transmitter, ambient probe and relay outputs.

Technical specifications



Parameter	Accuracy ⁽¹⁾	Measuring range	Resolution	Response time
Channel 1 Pt100 temperature (°C, °F)	±0.3% of reading ±0.25°C According to probe	From -20 to +80°C (ambient model) From -100 to +400°C (remote model)	0.1°C	T ₉₀ = 0.9 second for V _{air} = 1 m/s
Channel 2 Pt100 temperature (°C, °F) or Wet temperature (°C _{tw} , °F _{tw})	According to probe	From -100 to +400°C From -50 to 100°C _{tw}	0.1°C 0.1°C _{tw}	
Relative humidity ⁽²⁾ (%RH)	-	From 0 to 100% RH	0.1% RH	
Dew point ⁽²⁾ (°C _{td} , °F _{td})	-	From -50 to +100°C _{td}	0.1°C _{td}	
Absolute humidity ⁽²⁾ (g/m ³)	-	From 0 to 600 g/m ³	0.1 g/m ³	
Enthalpy ⁽²⁾ (kJ/kg)	-	From 0 to 15 000 kJ/kg	From 0 to 9999.9: 0.1 kJ/kg From 10 000 to 15 000: 1 kJ/kg	
Combination ratio ⁽²⁾ (g/kg)	-	From 0 to 9999.9 g/kg	0.1 g/kg	

TM210 transmitter can measure up to two temperatures (temperature 1 and temperature 2). When two temperature probes are connected, the transmitter can display the difference between both measured temperatures. It can also calculate different parameters in psychrometry thanks to the KHP psychrometric probe available as option (only for models with two Pt100 terminal blocks).

⁽¹⁾All the accuracies indicated in this technical datasheet were stated in laboratory conditions, and can be guaranteed for measurements carried out in the same conditions, or carried out with calibration compensation.

⁽²⁾Calculated values.

General features

Power supply	24 Vac / Vdc $\pm 10\%$ Warning: risk of electric shock 
Output	2 x 4-20 mA or 2 x 0-20 mA or 2 x 0-5 V or 2 x 0-10 V (4 wires) Common mode voltage <30 Vac Maximum load: 500 Ohms (0/4-20 mA) / Minimum load: 1 K Ohms (0-5/10 V)
Relay outputs	2 changeover relays 3 A / 230 V. NO: 5A / NC: 3A / 240 Vac
Galvanic isolation	Appareil entièrement protégé par DOUBLE ISOLATION ou ISOLATION RENFORCÉE  Outputs
Consumption	6 VA
Electrical connection	Screw terminal block for cable 2.5 mm ² Carried out according to the code of good practice
Type of sensor	Pt100 1/3 as per DIN IEC751
Type of fluid	Air and neutral gases
PC communication	USB-Mini Din cable
Environment	Air and neutral gases
Conditions of use (°C/%RH/m)	From -10 to +50°C. In non-condensing condition. From 0 to 2000 m.
Storage temperature	From -10 to +70°C
Security	Protection class II; Pollution degree 2; Overvoltage category 2 (OVCI)
European directives	2014/30/UE CEM ; 2014/35/UE Basse Tension ; 2011/65/UE RoHS II ; 2012/19/UE DEEE

Features of the housing

Material	ABS V0 selon UL94
Protection	IP65
Display	75 x 40 mm, LCD 19 digits 2 lines. Height of digits: Values: 10 mm; Units: 5 mm
Cable gland	For cables Ø8 mm maximum
Weight	340 g

Technical features of probes

Different Pt100 temperature probes are available on the range from -100 à +400 °C.

Please contact us in order to define the type of probe that corresponds to your need.



Dimensions

All dimensions are in millimeters.

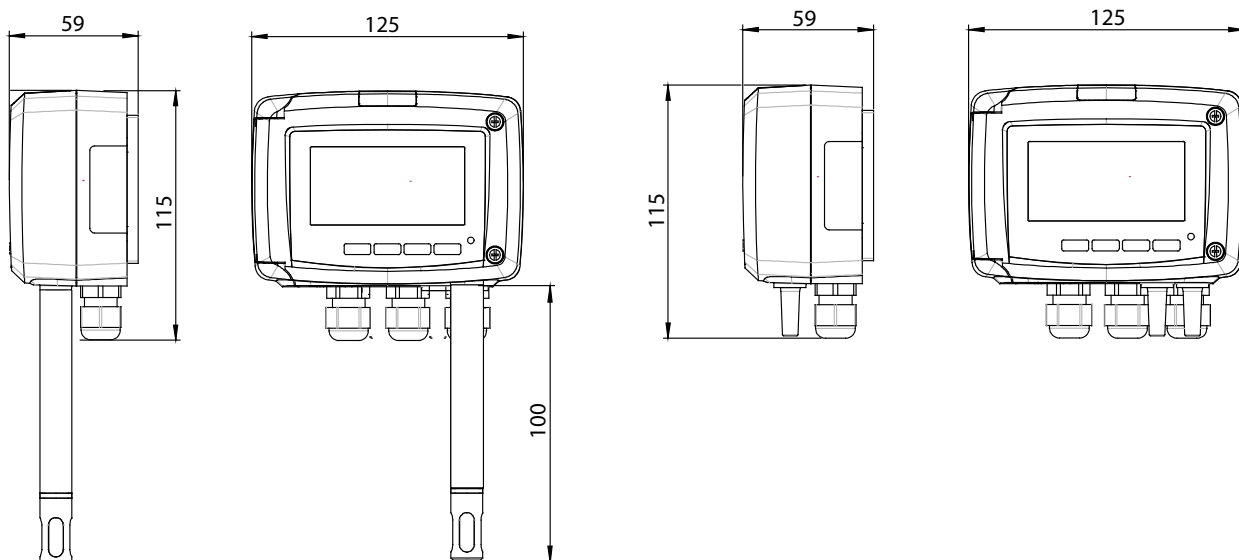

Ambient model

Remote model

Connectiques

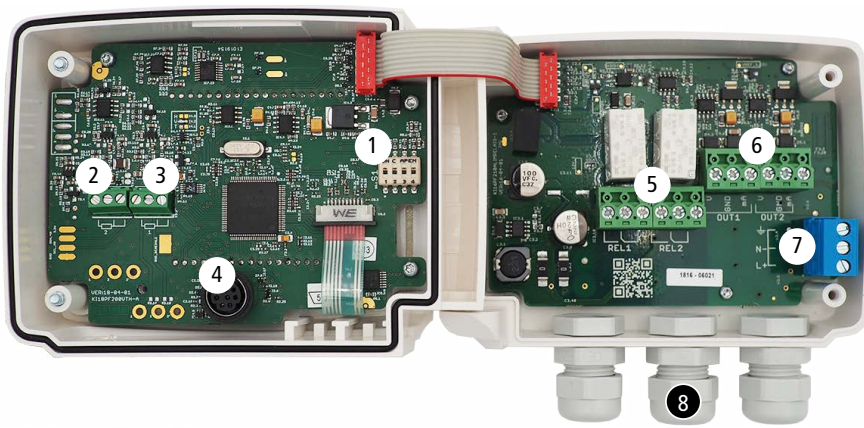

1. DIP switch (c)
2. Pt100 n°1 terminal block
3. Pt100 n°2 terminal block
4. LCC-S software connection
5. Relays
6. Analogue outputs (a)
7. Power supply terminal block (b)
8. Cable glands

Power supply type (b) specified on the label on the side of the transmitter

TM210-BXX-R
 Power supply: 24 Vac/Vdc $\pm 10\%$
 50-60 Hz 6 VA
 Output: 0/4...20 mA / 0...5/10 V

24 Vac/Vdc

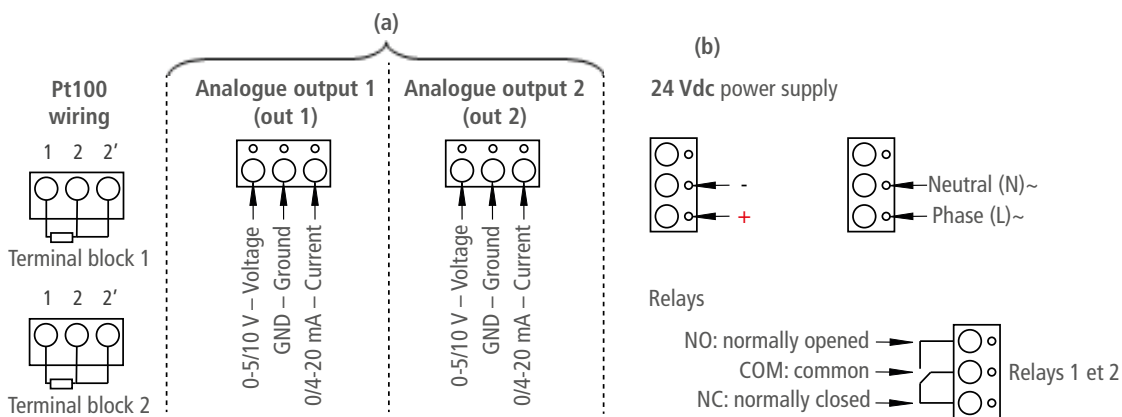

Electrical connections as per NFC15-100 standard



This connection must be made by a formed and qualified technician. To make the connection, the transmitter must not be energized. The presence of a switch and a circuit breaker upstream the device is compulsory

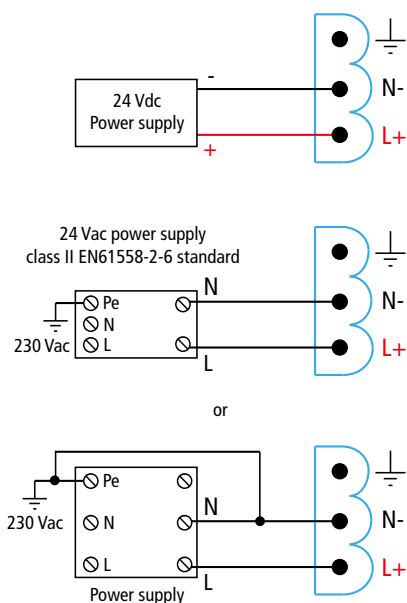

The selection of the output signal in voltage (0-10 V or 0-5 V) or in current (4-20 mA or 0-20 mA) is made via the DIP switch (c) of the electronic board of the transmitter: put the on-of switches as shown in the table below:

Configurations	4-20 mA	0-10 V	0-5 V	0-20 mA
Combinations				

- Connection of the output in current 4-20 mA:
- Connection of output in voltage 0-10 V:

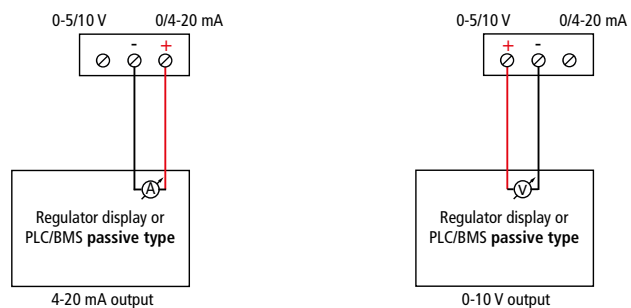

Configuration of the transmitters

It is possible on the class 210 to configure all the parameters of the transmitter: units, measuring ranges, outputs, channels, calculation functions, etc, via different methods:

- **Keypad for models with display:** a code-locking system allows to secure the installation (See class 210 transmitters user manual).
- **Software (optional) on all models.** Simple user-friendly configuration. See LCC-S user manual.

Configurable analogue output:

It is possible to configure your own intermediary ranges

Caution: the minimum difference between the high range and the low range is 20.

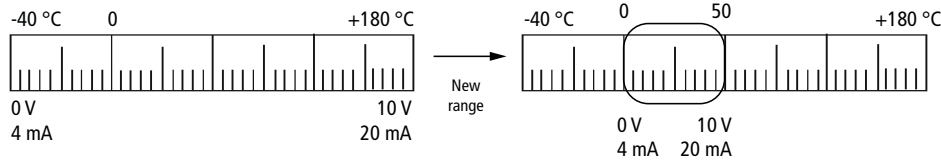

Mounting

To mount the transmitter, mount the ABS plate on the wall (drilling: $\varnothing 6$ mm, screws and pins are supplied).

Insert the transmitter on the fixing plate (see A on the drawing beside). Rotate the housing in clockwise direction until you hear a "click" which confirms that the transmitter is correctly installed.

Maintenance

Please avoid any aggressive solvent. Please protect the transmitter and its probes from any cleaning product containing formalin, that may be used for cleaning rooms or ducts.

Calibration

Outputs diagnostic: With this function, you can check with a multimeter (or on a regulator / display, or a PLC / BMS) if the transmitter outputs work properly. The transmitter generates a voltage of 0 V, 5 V and 10 V or a current of 4 mA, 12 mA and 20 mA

Certificate: Class 210 transmitters are supplied with adjusting certificates. Calibration certificates are available as an option.

Precautions for use

Please always use the device in accordance with its intended use and within parameters described in the technical features in order not to compromise the protection ensured by the device.

Options and accessories

Name	Reference
Configuration software with USB cable	LCC-S
Calibration certificate	-
Pt100 temperature probes	-
Psychrometric probe	KHP



Only the accessories supplied with the device must be used.

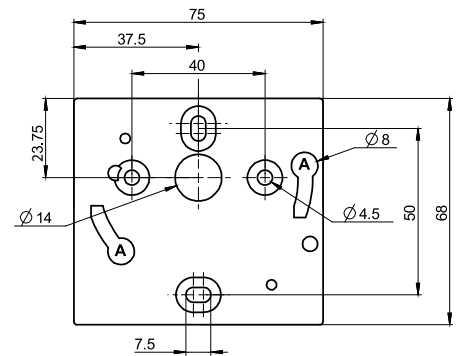

Les dimensions sont exprimées en millimètres.

