

› GND Board Series

SIP Solid State Relays

PCB Mount – DC Output

- › Output Current of 4 or 10 Amps
- › Output Voltage of 2-60 V_{DC}, 7-36 V_{DC}
- › Control Voltage of 4-10 V_{DC}, 4-30 V_{DC}, 10-30 V_{DC}
- › Classic SIP package for Printed Circuit Boards
- › DC Switching
- › CE and UKCA Compliance
- › Built-in Output Overvoltage Protection

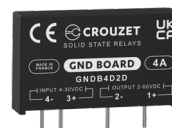

GNDB4D2D

Product Selection - DC Switching (DC Loads)		
Rated Load Current	4A ⁽⁹⁾	10A
Output Voltage	2-60 V _{DC}	7-36 V _{DC}
Control Voltage		
4-30 V _{DC}	GNDB4D2D	
4-10 V _{DC}		GNDB10D1E
10-30 V _{DC}		GNDB10B1E

Part Number System
GND Board

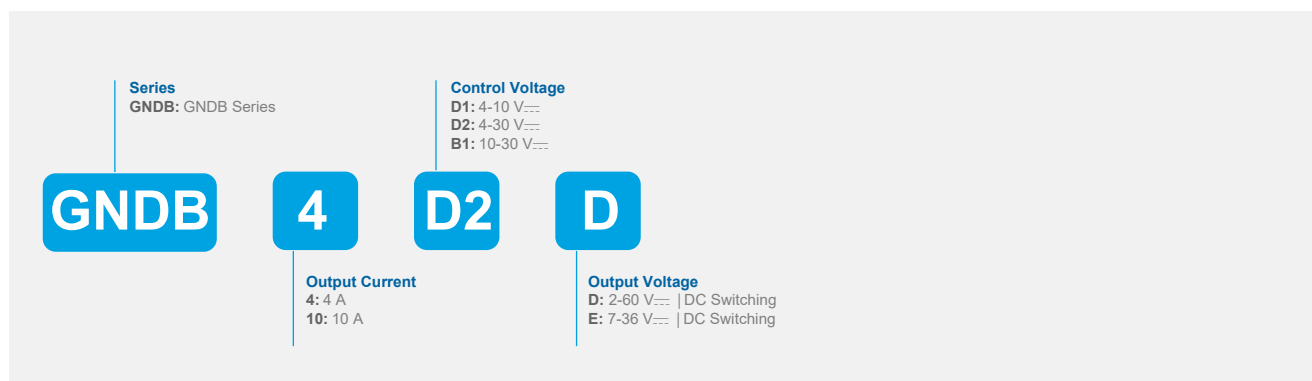

Do you need an adapted or customized solution? Contact us on www.crouzet.com

Description:

Crouzet Solid State Relays are designed to be used in almost any application, offering very long life expectancy and are easy to install, easy to use, robust and multipurpose.

For more information about Crouzet's Solid State relays, please visit www.crouzet.com.

Output Characteristics ⁽¹⁾		
Description	4A ⁽⁹⁾	10A
Minimum Load Current [mA _{rms}]	5	0.1
1 Second surge current @ Ta=25 °C [A _{peak}]	10	N/A
Maximum 1 Cycle Surge Current [A _{peak}]	10	100 @t=10ms
Maximum On-State Voltage Drop @ Rated Current [V _{peak}]	1.6	0.2
Thermal Resistance Junction to Case (R _{jc}) [°C/W]	1.66	1.36
Minimum Heat Sink for Rated Current @ 40 °C [°C/W]	No heatsink	
Operating Voltage [V _{rms}]	2-60 V _~	7-36 V _~
Transient Voltage [V _{peak}] ⁽²⁾	60	
Maximum Off-State Leakage Current @ Rated Voltage [mA _{rms}]	1	0.1
Minimum Off-State dv/dt @ Maximum Rated Voltage [V/μsec]	200	N/A
Minimum Power Factor	GNDB4D2D: 0.45 but Overvoltage (Varistor/Diode) and free-wheel diode protection required GNDB10D1E: 0.45 but free-wheel diode protection required GNDB10B1E: 0.45	

Input Characteristics ⁽¹⁾			
Control Voltage Range	4-30 V _~	4-10 V _~	10-30 V _~
Part Numbers	GNDB4D2D	GNDB10D1E	GNDB10B1E
Maximum Reverse Voltage	-30 V _~	-10 V _~	-30 V _~
Minimum Turn-On Voltage	3 V _~		7 V _~
Must Turn-Off Voltage	1 V _~		
Minimum Input Current (for on-state) [mA]	2	7	6
Maximum Input Current [mA]	30	32	30
Nominal Input Impedance [Ohms]	1000	270	1000
Maximum Turn-On Time [msec]	0.2	0.01	
Maximum Turn-Off Time [msec]	0.8	0.15	

General Characteristics		
Description	4A ⁽⁹⁾	10A
Dielectric Strength, Input to Output (50/60 Hz) [V]	2500	
Dielectric Strength, Input/Output to Ground (50/60 Hz) [V]	N/A	2500
Minimum Insulation Resistance (@ 500 V _~) [Ohms]	10 ⁹	
Maximum Capacitance, Input/Output [pF]	8	
Ambient Operating Temperature Range [°C] ⁽⁷⁾	-40 to 80	
Ambient Storage Temperature Range [°C]	-40 to 100	
Weight (typical) [g]	20.5	15
Housing Material	UL94 V-0	
Baseplate Material	N/A	Ceramic Substrate
Input Terminal Screw Torque Range [in-lb/Nm]	N/A	
Load Terminal Screw Torque Range [in-lb/Nm]	N/A	
SSR Mounting Screw Torque Range [in-lb/Nm]	N/A	
Humidity per IEC60068-2-78 [%]	40-85	
LED Input Status Indicator	No LED	
MTBF (Mean Time Between Failures) at 40 °C ambient temperature [years] ⁽⁸⁾	69	42
MTBF (Mean Time Between Failures) at 60 °C ambient temperature [years] ⁽⁸⁾	50	28
MTTFd [years]	313	138

General Notes	
(1)	All parameters at 25 °C unless otherwise specified
(2)	Output will self trigger between 450-600 Vpk not suitable for capacitive loads
(7)	AC models operating range is -20 to 80 °C
(8)	All parameters at 50 % power rating and 100 % duty cycle (contact tech support for detailed report)
(9)	4 A at 20°C; 3.5 A at 40°C

Diagrams
Wiring

GND Board Series

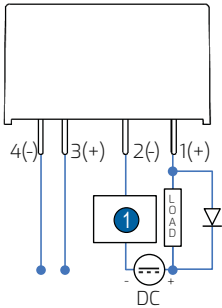

① Protection Equipment: Short circuit protection
GNDB4D2D: it is recommended to add an overvoltage protection

Diagrams
Equivalent Circuit Block

GNDB4D2D, GND Board Series 4-30 V_{DC} control; 2-60 V_{DC} output - DC switching (DC Loads)

Input Current vs Input Voltage
Standard Regulated DC inputs

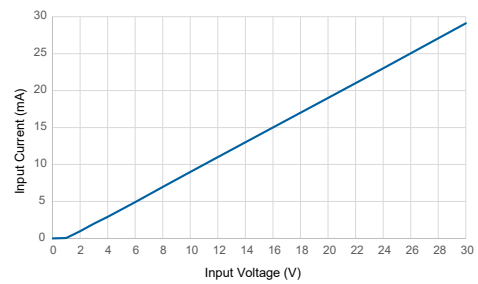
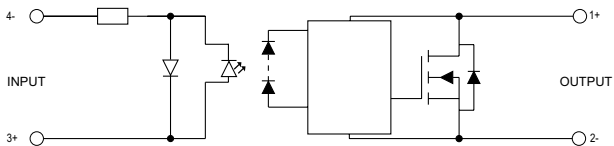

GNDB10D1E, GN Board Series 4-10 V_{DC} control; 7-36 V_{DC} output - DC switching (DC Loads)

Input Current vs Input Voltage
Standard Regulated DC inputs

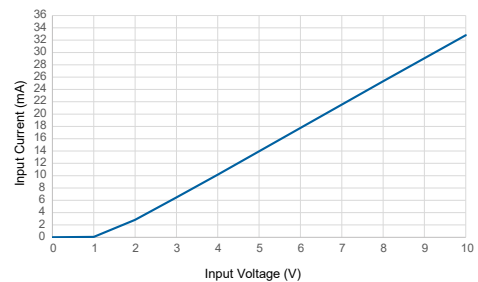
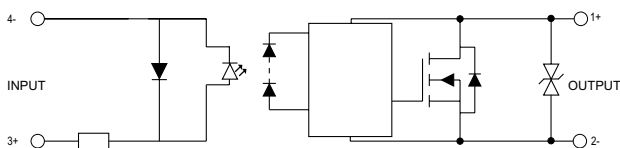

GNDB10B1E, GN Board Series 10-30 V_{DC} control; 7-36 V_{DC} output - DC switching (DC Loads)

Input Current vs Input Voltage
Standard Regulated DC inputs

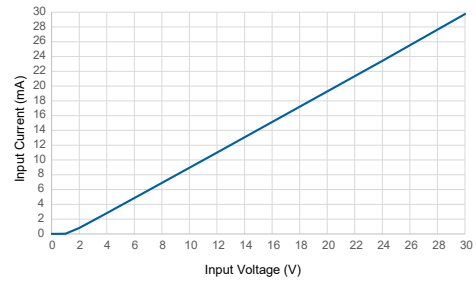
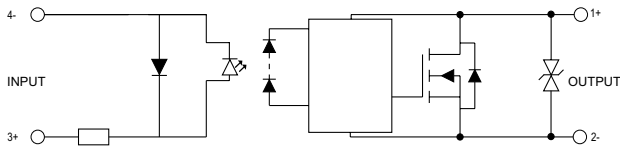

Diagrams

Dimensions (mm)

GNDB4D2D

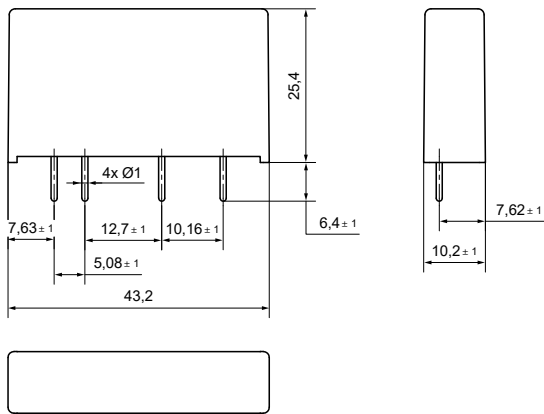

GNDB10D1E - GNDB10B1E

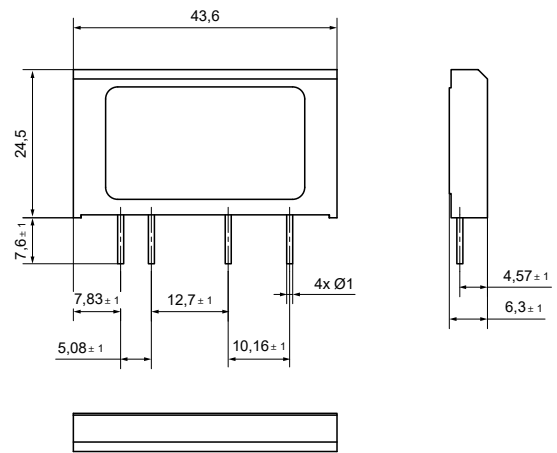

Curves

Thermal Derating Curves

GNDB4D2D

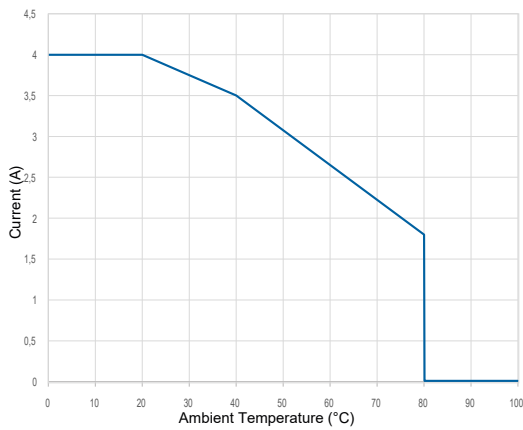

GNDB10D1E - GNDB10B1E

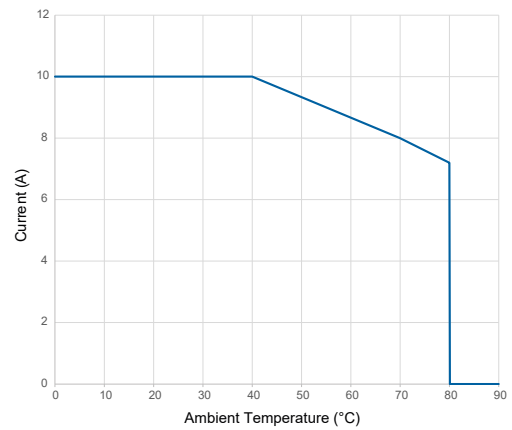

Standards & Electromagnetic Compatibility Specification

EN61000-4-4 Immunity to fast transients / bursts

EN61000-4-5 Immunity to surges

Standards

**Warning:**

The product information contained in this catalogue is given purely as information and does not constitute a representation, warranty or any form of contractual commitment. Crouzet and its subsidiaries reserve the right to modify their products without notice. It is imperative that we should be consulted over any particular use or application of our products and it is the responsibility of the buyer to establish, particularly through all the appropriate tests, that the product is suitable for the use or application. Under no circumstances will our warranty apply, nor shall we be held responsible for any application (such as any modification, addition, deletion, use in conjunction with other electrical or electronic components, circuits or assemblies, or any other unsuitable material or substance) which has not been expressly agreed by us prior to the sale of our products.