

## 24 x 48 Multifunction CTR24L - 2511 Part number 87623570



- High brightness display : 6-digit LED, height 8 mm
- Maximum input frequency 50 k Hz
- Programmable multifunction : Counter/Tachometer/Chronometer
- Reset on panel or external with inhibition option
- Supply : 10 →30 VDC
- Easy to program
- Scaling factor (Counter - Tachometer)
- Decimal point (Counter - Tachometer)
- Timing range 0.001 s →999,999 hrs (Chronometer)
- Impulses or time measured in hrs/min/sec and in real time (Chronometer)
- Accessories for 50 x 25 mm cut-out

### Part numbers

Type	Functions
87623570 CTR24L - 2511	Counter, Tachometer, Chronometer

### Specifications

#### Physical details and protection

Consumption	10 →30 VDC max 55 mA with protection against polarity reversal
Connection by 5 screw terminals at rear of casing	•
Connection capacity	1,5 mm <sup>2</sup>
Fixed using bracket	•
Degree of protection front face	IP 65
Data memory	EEPROM
Temperature limits use (°C)	-20 →+55
Temperature limits stored (°C)	-25 →+70
Dielectric strength	According to EN 61010-1 : 2000 V/50 Hz/1 min
Conformity to standards	EN 61000-6-2 - EN 55011 class B
Altitude	2000 m
Certifications	UL - cULus (pending) - CE
Weight (g)	50

#### Operating characteristics

Functions	Impulse counter, Tachometer, Chronometer
Display	6-digit LED
Height digits (mm)	8

#### Inputs specifications

Inputs	2 counter inputs, 1 reset input
High level	0 →0,2 x U <sub>b</sub> VDC
Low level	0,6 x U <sub>b</sub> →30 VDC
Cyclical ratio	Any (maximum frequency given for a cyclical ratio = 1/1) Schmitt trigger input
Polarity	NPN or PNP for all inputs (programming)
Minimum impulse duration for reset	5 ms
Frequency of filtered input	Filter active : 30 Hz Filter disabled : maximum frequency (programming)
Input impedance (kΩ)	Appr. 5

#### Impulse counter

Display details	- 19 999 →999 999
Elimination of non-significant zeros	•
Counting input modes	Cnt.Dir →Counter input INPA and counter direction input INPB Up.dn →INPA INPB differential counting Up.up →Sum of INPA + INPB QuAd →Phase discriminator QuAd2 →Phase discriminator with doubling of impulses QuAd4 →Phase discriminator with quadrupling of impulses
Inputs INPA / INPB	Dynamic
Reset input (terminal 5)	Dynamic Reset input connected in parallel with the red SET/RESET button Sets the counter to the defined preset value
Reset to zero - Panel	If not locked during programming
Remise à zéro - Externe (borne 5)	If not locked during programming
Scale factor	1 →99,9999
Scaling factor	1 →99,9999
Decimal point	0 0,0 0,00 0,000

Maximum counting frequency	CntDir →50 k Hz UpDown →25 k Hz UpUp →25 k Hz Quad1 →25 k Hz Quad2 →25 k Hz Quad4 →15 k Hz
----------------------------	---

**Tachometer**

Display details	0 →999 999
Elimination of non-significant zeros	■
Conversion time	1/s ou 1/min
Input INPA	Dynamic
Accuracy	< 0,1 %
Measurement principle	< 38 Hz : measurement of period duration > 38 Hz : measurement with duration time base = 26.3 ms
Scale factor	1 →99,9999
Scaling factor	1 →99,9999
Decimal point	0 0,0 0,00 0,000
Maximum counting frequency	50 k Hz

**Chronometer**

Display details	0,001 s →999 999 h
Elimination of non-significant zeros	■
Functions	GatE.Lo →Time measurement if INPB is not active GatE.hi →Time measurement if INPB is active Inb.Inb →Time measurement on/off via the INPB edge InA.Inb →Measurement on via the INPA edge, measurement off via the INPB edge
Input INPA	Start
Input INPB	Start/Stop or Gate (depends on the input mode chosen)
Remise à zéro - Externe (borne 5)	If not locked during programming
Reset input (terminal 5)	Dynamic Reset input connected in parallel with the red SET/RESET button Sets the counter to the defined preset value
Reset to zero - Panel	If not locked during programming
Accuracy	< 50
Decimal point	0 0,0 0,00 0,000
Time ranges	0,001 s →999 999 s 0,001 min →99 999 min 0,001 h →999 999 h 00 h 00 min 01 s →99 h 59 min 59 s

**Accessories**

Description	Code
Adaptor for 50 x 25 mm cut-out - Fixed with screws	26546843
Adaptor for 50 x 25 mm cut-out - Fixed with clips	26546844
DIN rail adaptor	26546840
Clip-fixing kit (supplied with the product)	26546848

**Dimensions (mm)**

CTR24L - 2511

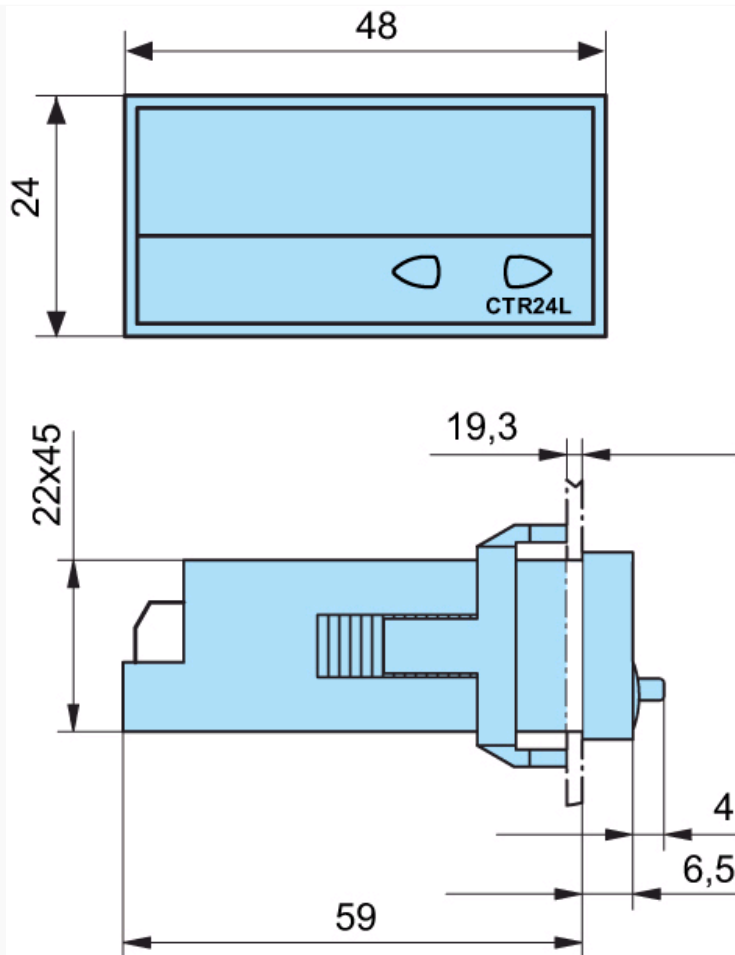

#### Dimensions (mm)

##### Fixing strip with clip-on yoke

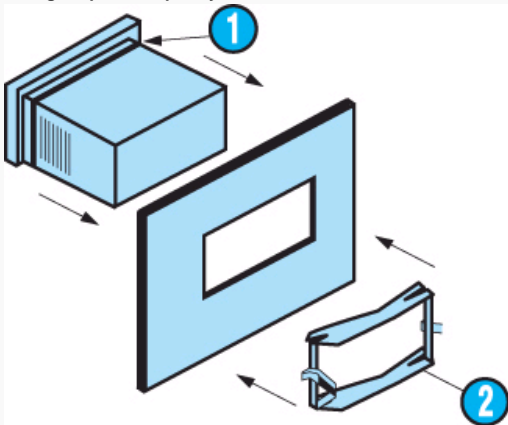

N°	Legend
1	Seal
2	Fixing yoke

#### Dimensions (mm)

##### Panel cut-out

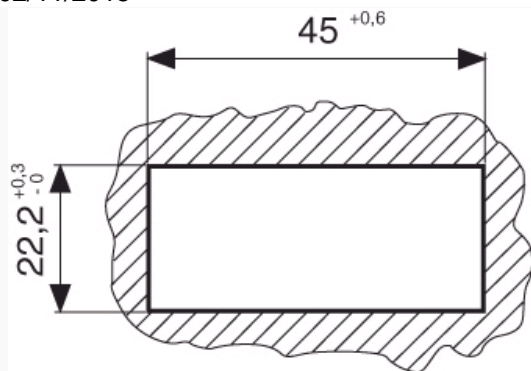

Dimensions (mm)

4 appliances

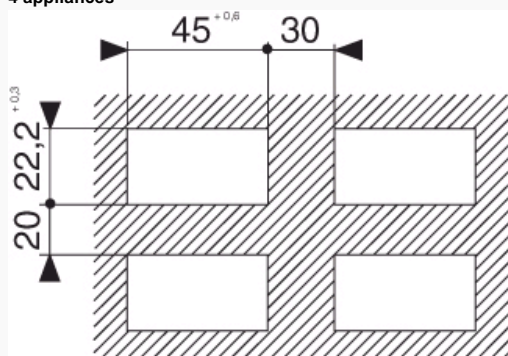

Dimensions (mm)

26546843 - Adaptor for 50 x 25 mm cut-out - Fixed with screws

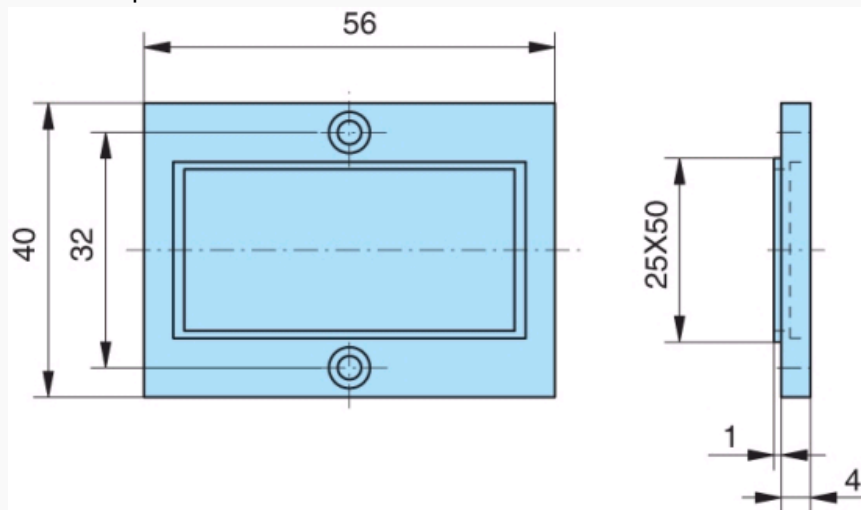

Dimensions (mm)

26546844 - Adaptor for 50 x 25 mm cut-out - Fixed with clips

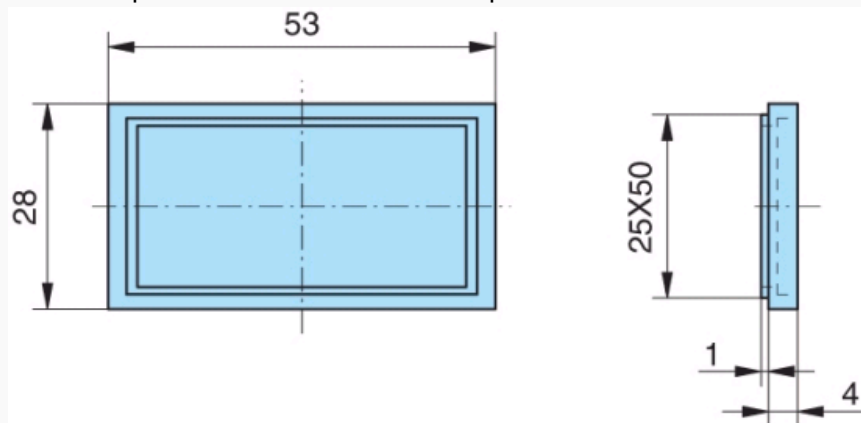

Accessory supplied with the counter

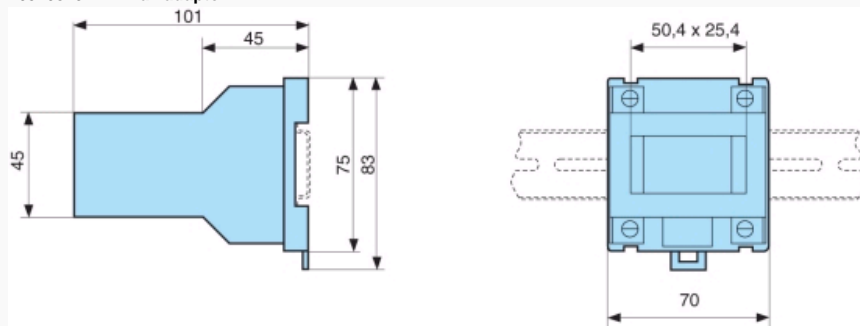
**Dimensions (mm)****26546840 - DIN rail adaptor**

Accessory supplied with the counter

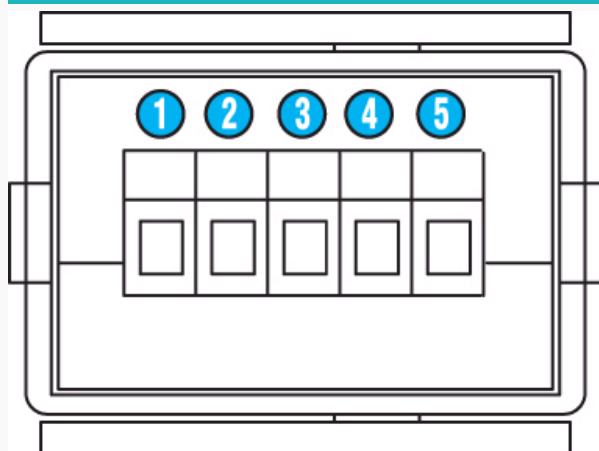
**Connections**

N°	Legend
1	Supply : 10 →30 VDC
2	Supply : GND (0 VDC)
3	INPA
4	INPB (NC in tachometer mode)
5	SET/RESET (NC in tachometer mode)

**Applications****Programming diagram**

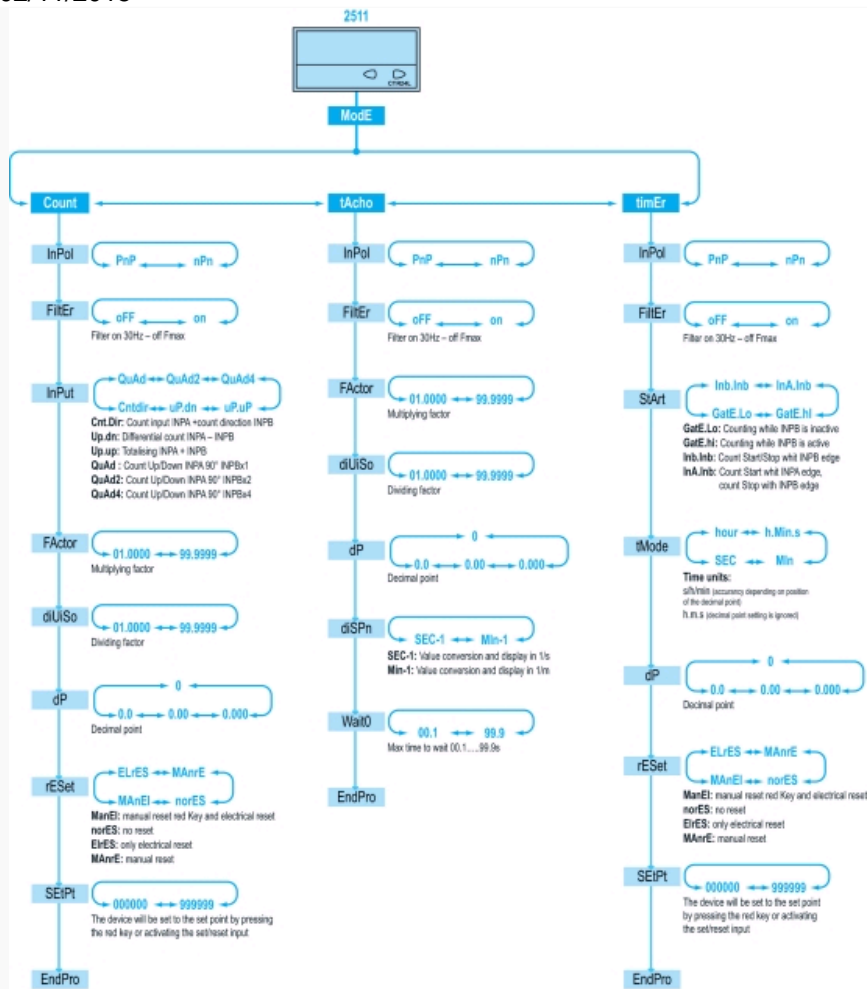

Count frequency:

DC power supply	24V	12V
Input level	Standard	
Typ. low	2.5V	2.0V
Typ. High	22.0V	10V
Fmax*	KHz	KHz
CntDir	50	20
UpDown	25	15
Up.up	25	15
Quad1	25	15
Quad2	25	15
Quad4	15	15

Count frequency:

DC power supply	24V	12V
Input level	Standard	
Typ. low	2.5V	2.0V
Typ. High	22.0V	10V
Fmax*	KHz	KHz
Tacho	50	20

Counting ranges:

Seconds	0.001s...999.999s
Minutes	0.001min...999.999min
Hours	0.001h...999.999h
h.min.s	0000mm/1s...9999mm/99s