

Millenium 3 Smart

→ Smart "Compact" range with display



- Highly visible blue LCD with 4 lines of 18 characters and configurable backlighting
- Allow the use of the entire library of specific functions blocs of the software workshop
- Extended temperature range (-20 °C → +70 °C)
- Analog inputs 0-10 VDC, Potentiometer, NTC, LDR (0-20 mA/Pt100 with converters)
- Selective parameter setting: you can choose the parameters that can be adjusted on the front panel



CD12



CD20

Part numbers

Type	Input	Output	Supply	Code
CD12 Smart	8 digital (including 4 analog)	4 relays 8 A	24 V ---	88974041
	8 digital (including 4 analog)	4 solid state 0.5 A (including 1 PWM)	24 V ---	88974042
	8 digital	4 relays 8 A	100 → 240 V ~	88974043
	8 digital	4 relays 8 A	24 V ~	88974044
	8 digital (including 4 analog)	4 relays 8 A	12 V ---	88974045
	8 digital (including 4 analog)	4 solid state 0.5 A (including 1 PWM)	12 V ---	88974046
CD20 Smart	12 digital (including 6 analog)	8 relays 8 A	24 V ---	88974051
	12 digital (including 6 analog)	8 solid state 0.5 A (including 4 PWM)	24 V ---	88974052
	12 digital	8 relays 8 A	100 → 240 V ~	88974053
	12 digital	8 relays 8 A	24 V ~	88974054
	12 digital (including 6 analog)	8 relays 8 A	12 V ---	88974055

Accessories

Type	Description	Code
M3 Soft	Multilingual programming software containing specific library functions (CD-ROM)	88970111
PA	EEPROM memory cartridge	88970108
PA	3 m serial link cable: PC → Millenium 3	88970102
PA	USB cable 3 m: PC → Millenium 3	88970109
PA	Millenium 3 interface → Bluetooth® (class A 10 m)	88974104

Specific characteristics*

Operating temperature	-20 → +70 °C
Operating factor	100 % (6 A relays) 66 % (8 A relays)
Storage temperature	-40 → +80 °C
LCD display	Display with 4 lines of 18 characters, white characters on a blue background

Dimensions (mm)

CD12 Smart

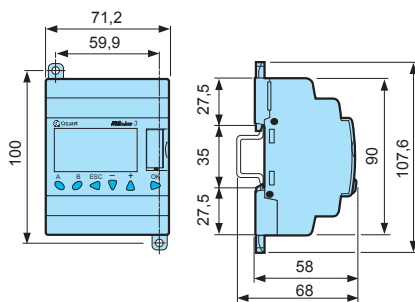

CD20 Smart

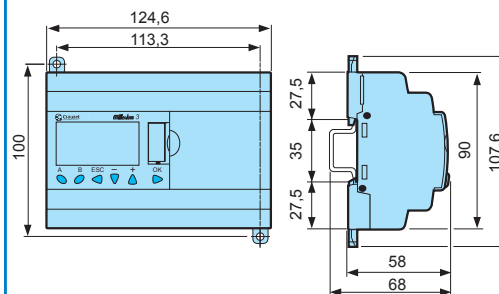

*Also see Millenium 3 Smart and Essential General characteristics

Millenium 3 Smart

→ Smart "Compact" range without display

- Efficient and economical version, without display or keys setting
- Allow the use of the entire library of specific functions blocs of the software workshop
- Extended temperature range (-30 °C → +70 °C)
- Analog inputs 0-10 VDC, Potentiometer, NTC, LDR (0-20 mA/Pt100 with converters)



CB12



CB20

Part numbers

Type	Input	Output	Supply	Code
CB12 Smart	8 digital (including 4 analog)	4 relays 8 A	24 V $\overline{\text{---}}$	88974021
	8 digital	4 relays 8 A	100 → 240 V \sim	88974023
	8 digital	4 relays 8 A	24 V \sim	88974024
	8 digital (including 4 analog)	4 solid state 0.5 A (including 1 PWM)	12 V $\overline{\text{---}}$	88974026
CB20 Smart	12 digital (including 6 analog)	8 relays 8 A	24 V $\overline{\text{---}}$	88974031
	12 digital	8 relays 8 A	100 → 240 V \sim	88974033
	12 digital	8 relays 8 A	24 V \sim	88974034

Accessories

Type	Description	Code
M3 Soft	Multilingual programming software containing specific library functions (CD-ROM)	88970111
PA	EEPROM memory cartridge	88970108
PA	3 m serial link cable: PC → Millenium 3	88970102
PA	USB cable 3 m: PC → Millenium 3	88970109
PA	Millenium 3 interface → Bluetooth® (class A 10 m)	88974104

Specific characteristics*

Operating temperature	-30 → +70 °C ($\overline{\text{---}}$); -20 → +70 °C (\sim)
Operating factor	100 % (6 A relays) 66 % (8 A relays)
Storage temperature	-40 → +80 °C

Dimensions (mm)

CB12 Smart

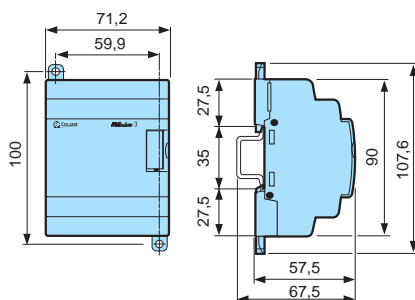

CB20 Smart

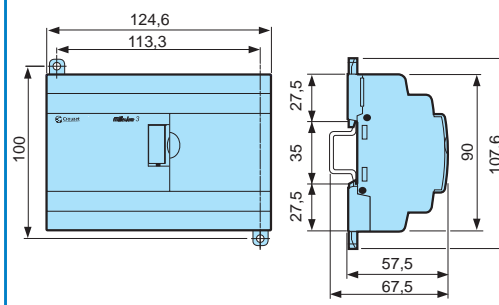

*Also see Millenium 3 Smart and Essential General characteristics

Millenium 3 Smart

→ Smart "Expandable" range with display



- Highly visible blue LCD with 4 lines of 18 characters and configurable backlighting
- Allow the use of the entire library of specific functions blocs of the software workshop
- Extended temperature range (-20 °C → +70 °C)
- Analog inputs 0-10 VDC, Potentiometer, NTC, LDR (0-20 mA/Pt100 with converters)
- Open to XN network communication extensions, digital I/O, analog, Pt100 extensions



XD10



XD26

Part numbers

Type	Input	Output	Supply	Code
XD10 Smart	6 digital (including 4 analog)	4 relays 8 A	24 V $\overline{\text{---}}$	88974141
	6 digital (including 4 analog)	4 solid state 0.5 A (including 1 PWM)	24 V $\overline{\text{---}}$	88974142
	6 digital	4 relays 8 A	100 → 240 V \sim	88974143
	6 digital	4 relays 8 A	24 V \sim	88974144
XD26 Smart	16 digital (including 6 analog)	10 relays (8 x 8 A relay and 2 x 5 A relay)	24 V $\overline{\text{---}}$	88974161
	16 digital (including 6 analog)	10 solid state 0.5 A (including 4 PWM)	24 V $\overline{\text{---}}$	88974162
	16 digital	10 relays (8 x 8 A relay and 2 x 5 A relay)	100 → 240 V \sim	88974163
	16 digital	10 relays (8 x 8 A relay and 2 x 5 A relay)	24 V \sim	88974164
	16 digital (including 6 analog)	10 relays (8 x 8 A relay and 2 x 5 A relay)	12 V $\overline{\text{---}}$	88974165
	16 digital (including 6 analog)	10 solid state 0.5 A (including 4 PWM)	12 V $\overline{\text{---}}$	88974166

Accessories

Type	Description	Code
M3 Soft	Multilingual programming software containing specific library functions (CD-ROM)	88970111
PA	EEPROM memory cartridge	88970108
PA	3 m serial link cable: PC → Millenium 3	88970102
PA	USB cable 3 m: PC → Millenium 3	88970109
PA	Millenium 3 interface → Bluetooth® (class A 10 m)	88974104

Specific characteristics*

Operating temperature	-20 → +70 °C
Operating factor	100 % (6 A relays) 66 % (8 A relays)
Storage temperature	-40 → +80 °C
LCD display	Display with 4 lines of 18 characters, white characters on a blue background

Dimensions (mm)

XD10 Smart

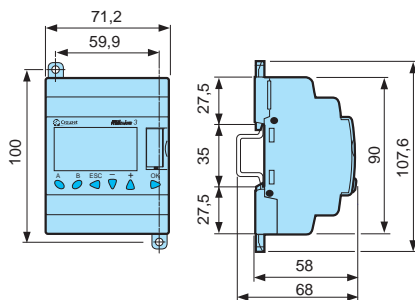

XD26 Smart

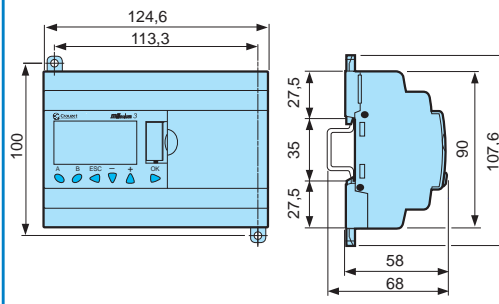

*Also see Millenium 3 Smart and Essential General characteristics

Millenium 3 Smart



→ Smart "Expandable" range without display

- Efficient and economical version, without display or keys setting
- Allow the use of the entire library of specific functions blocs of the software workshop
- Extended temperature range (-30 °C → +70 °C)
- Analog inputs 0-10 VDC, Potentiometer, NTC, LDR (0-20 mA/Pt100 with converters)
- Open to XN network communication extensions, digital I/O, analog, Pt100 extensions



XB10



XB26

Part numbers

Type	Input	Output	Supply	Code
XB10 Smart	6 digital (including 4 analog)	4 relays 8 A	24 V $\overline{\text{---}}$	88974131
	6 digital (including 4 analog)	4 solid state 0.5 A (including 1 PWM)	24 V $\overline{\text{---}}$	88974132
	6 digital	4 relays 8 A	100 → 240 V \sim	88974133
	6 digital	4 relays 8 A	24 V \sim	88974134
XB26 Smart	16 digital (including 6 analog)	10 relays (8 x 8 A relay and 2 x 5 A relay)	24 V $\overline{\text{---}}$	88974151
	16 digital (including 6 analog)	10 solid state 0.5 A (including 4 PWM)	24 V $\overline{\text{---}}$	88974152
	16 digital	10 relays (8 x 8 A relay and 2 x 5 A relay)	100 → 240 V \sim	88974153
	16 digital	10 relays (8 x 8 A relay and 2 x 5 A relay)	24 V \sim	88974154
	16 digital (including 6 analog)	10 relays (8 x 8 A relay and 2 x 5 A relay)	12 V $\overline{\text{---}}$	88974155

Accessories

Type	Description	Code
M3 Soft	Multilingual programming software containing specific library functions (CD-ROM)	88970111
PA	EEPROM memory cartridge	88970108
PA	3 m serial link cable: PC → Millenium 3	88970102
PA	USB cable 3 m: PC → Millenium 3	88970109
PA	Millenium 3 interface → Bluetooth® (class A 10 m)	88974104

Specific characteristics*

Operating temperature	-30 → +70 °C ($\overline{\text{---}}$); -20 → +70 °C (\sim)
Operating factor	100 % (6 A relays) 66 % (8 A relays)
Storage temperature	-40 → +80 °C

Dimensions (mm)

XB10 Smart

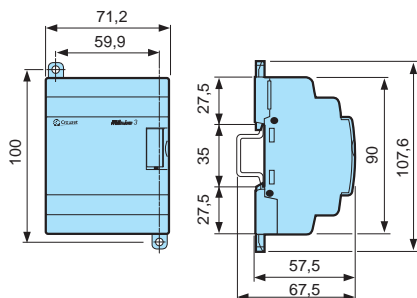

XB26 Smart

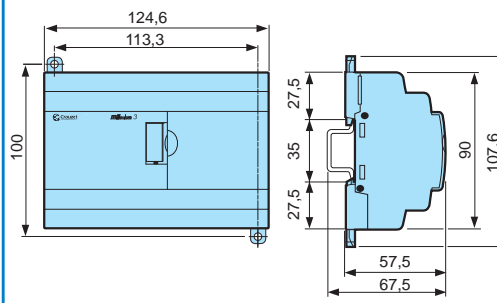

*Also see Millenium 3 Smart and Essential General characteristics

Millenium 3 Smart and Essential

→ I/O wiring



Inputs 12 V $\overline{\text{---}}$, 24 V $\overline{\text{---}}$

Bases: CD12, CD20, CB12, CB20, XD10, XD26, XB10, XB26

Extensions: XE10, XR06, XR10, XR14

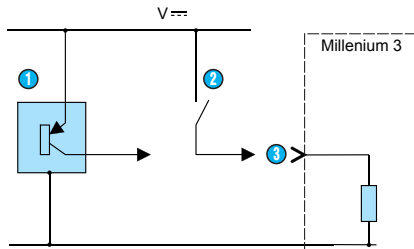

- ① 3-wire PNP sensor
- ② Contact
- ③ Digital input

Bases: CD12, CD20, CB12, CB20, XD10, XD26, XB10, XB26

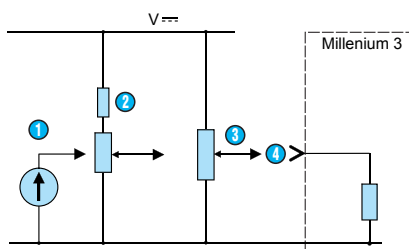

- ① 0-10 V (input set to 0-10 V)
- ② Potentiometer type mounting (input set to 0-10 V)
- ③ Potentiometer (input set as a potentiometer)
- ④ Analog input

Bases: CD12, CD20, CB12, CB20, XD10, XD26, XB10, XB26

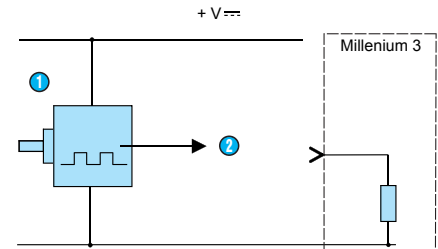

- ① Encoder
- ② High-speed digital input

Inputs 100-240 V \sim , 24 V \sim

Bases: CD12, CD20, CB12, CB20, XD10, XD26, XB10, XB26

Extensions: XE10, XR06, XR10, XR14

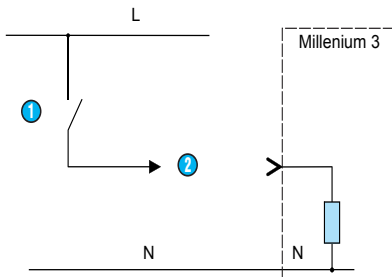

- ① Contact
- ② Digital input

Analog inputs

Extension: XA04

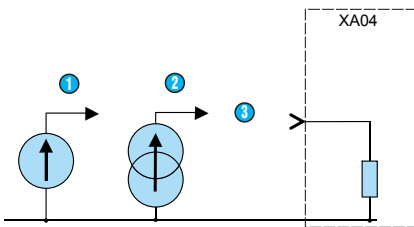

- ① 0-10 V
- ② 0-20 mA
- ③ Analog input

Extensions: XA03, XA04

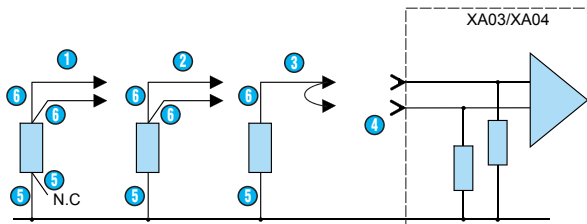

- ① Pt100 4-wire
- ② Pt100 3-wire
- ③ Pt100 2-wire
- ④ Analog inputs
- ⑤ White
- ⑥ Red

Millenium 3 Smart and Essential

Relay outputs

Bases: CD12, CD20, CB12, CB20, XD10, XD26, XB10, XB26

Extensions: XE10, XR06, XR10, XR14

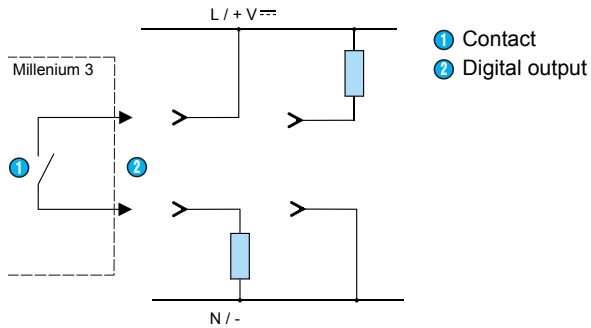

Solid state outputs

Bases: CD12, CD20, CB12, CB20, XD10, XD26, XB10, XB26

Extension: XA04

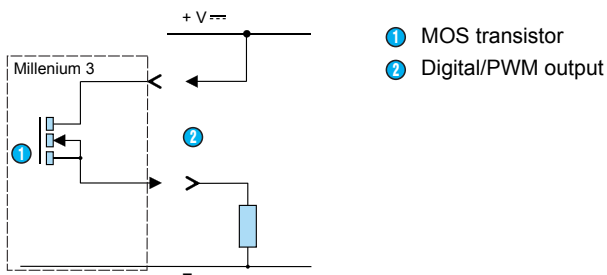

Analog outputs

Extension: XA04

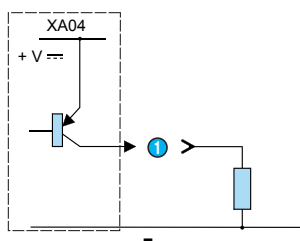

1 PWM output

Extension: XA04

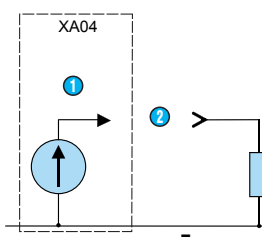

1 0-10 V
2 Analog output

Millenium 3 Smart and Essential

→ Input/output installations: Bases



"Compact" range: CD12, CD20, CB12, CB20

Inputs

CD12, CB12

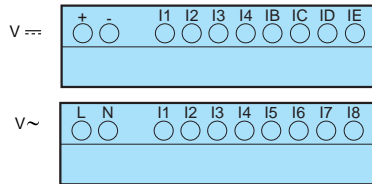

CD20, CB20

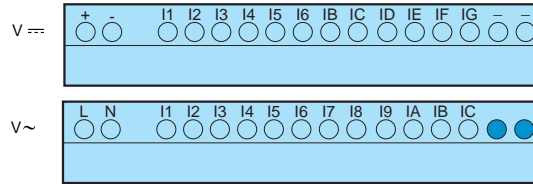

Relay outputs

CD12, CB12

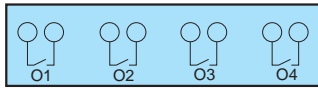

CD20, CB20

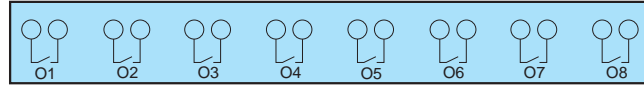

Solid state outputs

CD12, CB12

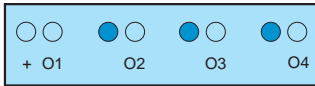

CD20

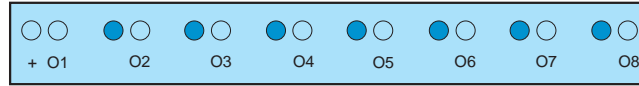

"Expandable" range: XD10, XD26, XB10, XB26

Inputs

XD10, XB10

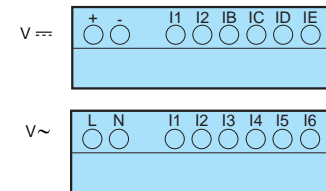

XD26, XB26

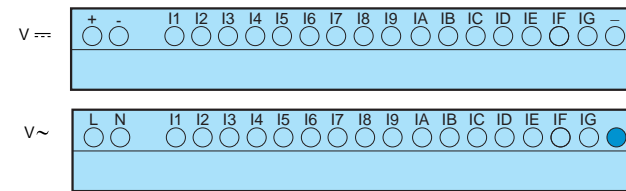

Relay outputs

XD10, XB10

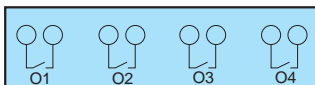

XD26, XB26

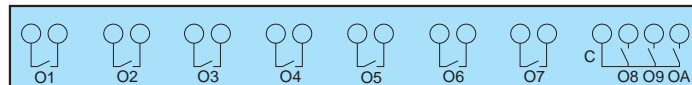

Solid state outputs

XD10

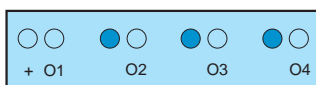

XD26

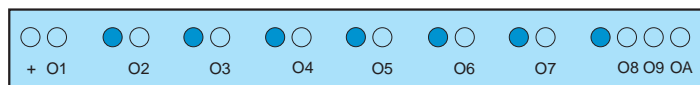

Millenium 3 Smart and Essential

→ General characteristics



- Millenium 3 compact range
- Millenium 3 expandable range



General environment characteristics for CB, CD, XD, XB, XR and XE product types

Certifications	CE, UL, CSA, GL
Conformity to standards (with the low voltage directive and EMC directive)	IEC/EN 61131-2 (Open equipment) IEC/EN 61131-2 (Zone B) IEC/EN 61000-6-2 IEC/EN 61000-6-3 (*) IEC/EN 61000-6-4 (*) Except configuration (88 970 1.1 or 88 970 1.2) + (88 970 250 or 88 970 270) + 88 970 241 class A (class B in a metal enclosure)
Earthing	Not included
Protection rating	In accordance with IEC/EN 60529: IP40 on front panel IP20 on terminal block
Overvoltage category	3 in accordance with IEC/EN 60664-1
Pollution	Degree: 2 in accordance with IEC/EN 61131-2
Max operating Altitude	Operation: 2000 m Transport: 3048 m
Mechanical resistance	Immunity to vibrations IEC/EN 60068-2-6, test Fc Immunity to shock IEC/EN 60068-2-27, test Ea
Resistance to electrostatic discharge	Immunity to ESD IEC/EN 61000-4-2, level 3
Resistance to HF interference	Immunity to radiated electrostatic fields IEC/EN 61000-4-3 Immunity to fast transients (burst immunity) IEC/EN 61000-4-4, level 3 Immunity to shock waves IEC/EN 61000-4-5 Radio frequency in common mode IEC/EN 61000-4-6, level 3 Voltage dips and breaks (~) IEC/EN 61000-4-11 Immunity to damped oscillatory waves IEC/EN 61000-4-12
Conducted and radiated emissions	Class B (*) in accordance with EN 55022, EN 55011 (CISPR22, CISPR11) group 1 (*) Except configuration (88 970 1.1 or 88 970 1.2) + (88 970 250 or 88 970 270) + 88 970 241 class A (class B in a metal enclosure)
Operating temperature Millenium 3 Essential and extensions	-20 → +55 °C (+40 °C in a non-ventilated enclosure) in accordance with IEC/EN 60068-2-1 and IEC/EN 60068-2-2
Operating temperature Millenium 3 Smart	-20 → +70 °C except CB and XB versions in V ~: -30 → +70 °C (+40 °C in a non-ventilated enclosure) in accordance with IEC/EN 60068-2-1 and IEC/EN 60068-2-2
Storage temperature Millenium 3 Essential and extensions	-40 → +70 °C in accordance with IEC/EN 60068-2-1 and IEC/EN 60068-2-2
Storage temperature Millenium 3 Smart	-40 → +80 °C in accordance with IEC/EN 60068-2-1 and IEC/EN 60068-2-2
Relative humidity	95 % max. (no condensation or dripping water) in accordance with IEC/EN 60068-2-30
Mounting	On symmetrical DIN rail, 35 x 7.5 mm and 35 x 15 mm, or on panel (2 x Ø 4 mm)
Screw terminals connection capacity	Flexible wire with ferrule = 1 conductor: 0.25 to 2.5 mm ² (AWG 24 → AWG 14) 2 conductors 0.25 to 0.75 mm ² (AWG 24 → AWG 18) Semi-rigid wire = 1 conductor: 0.2 to 2.5 mm ² (AWG 25 → AWG 14) Rigid wire = 1 conductor: 0.2 to 2.5 mm ² (AWG 25 → AWG 14) 2 conductors 0.2 to 1.5 mm ² (AWG 25 → AWG 16) Tightening torque = 0.5 N.m (4.5 lb-in) (tighten using screwdriver diam. 3.5 mm)

Processing characteristics of CB, CD, XD & XB product types

	Millenium 3 Smart and Essential versions XD, XB	Millenium 3 Essential versions CB, CD
Program size function blocks (FBD)	350 typical blocks 64 macros maximum 256 blocks maximum per macro	180 typical blocks 64 macros maximum 256 blocks maximum per macro
Memory size function blocks (FBD)	8 K	4 K
Number of lines in Ladder	120 lines	120 lines
LCD display	CD, XD: Display with 4 lines of 18 characters	
Programming method	Function blocks / SCF (Grafctet) or Ladder	
Program memory	Flash EEPROM	
Removable memory	EEPROM	
Data memory	368 bit/200 words	
Back-up time in the event of power failure	Program and settings in the controller: 10 years Program and settings in the plug-in memory: 10 years Data memory: 10 years	
Cycle time	FBD: 6 → 90 ms (typically 20 ms) Ladder: typically 20 ms	
Response time	Input acquisition time: + 1 to 2 cycle times	
Clock data retention	10 years (lithium battery) at 25 °C	
Clock drift	Drift < 12 min/year (at 25 °C) 6 s/month (at 25 °C with user-definable correction of drift)	
Timer block accuracy	1 % ± 2 cycle times	
Start up time on power up	< 1.2 s	

Characteristics of products with AC power supplied

Supply	24 V ~	100 → 240 V ~
Nominal voltage	24 V ~	100 → 240 V ~
Operating limits	-15 % / +20 % or 20.4 V ~ → 28.8 V ~	-15 % / +10 % or 85 V ~ → 264 V ~
Supply frequency range	50/60 Hz (+4 % / -6 %) or 47 → 53 Hz / 57 → 63 Hz	50/60 Hz (+4 % / -6 %) or 47 → 53 Hz / 57 → 63 Hz
Immunity from micro power cuts	10 ms (repetition 20 times)	10 ms (repetition 20 times)
Max. absorbed power	CB12-CD12-XD10-XB10: 4 VA CB20-CD20: 6 VA XD10-XB10 with extension: 7.5 VA XD26-XB26: 7.5 VA XD26-XB26 with extension: 10 VA	CB12-CD12-XD10-XB10: 7 VA CB20-CD20: 11 VA XD10-XB10 with extension: 12 VA XD26-XB26: 12 VA XD26-XB26 with extension: 17 VA
Isolation voltage	1780 V ~	1780 V ~
Inputs	24 V ~	100 → 240 V ~
Input voltage	24 V ~ (-15 % / +20 %)	100 → 240 V ~ (-15 % / +10 %)
Input current	4.4 mA @ 20.4 V ~ 5.2 mA @ 24.0 V ~ 6.3 mA @ 28.8 V ~	0.24 mA @ 85 V ~ 0.75 mA @ 264 V ~
Input impedance	4.6 kΩ	350 kΩ
Logic 1 voltage threshold	≥ 14 V ~	≥ 79 V ~
Making current at logic state 1	> 2 mA	> 0.17 mA
Logic 0 voltage threshold	≤ 5 V ~	≤ 20 V ~ (≤ 28 V ~ : XE10, XR06, XR10, XR14)
Release current at logic state 0	< 0.5 mA	< 0.5 mA
Response time with function blocks programming	Configurable in increments of 10 ms 50 ms min. up to 255 ms State 0 → 1 (50/60 Hz)	Configurable in increments of 10 ms 50 ms min. up to 255 ms State 0 → 1 (50/60 Hz)
Response time with Ladder programming	50 ms State 0 → 1 (50/60 Hz)	50 ms State 0 → 1 (50/60 Hz)
Maximum counting frequency	In accordance with cycle time (Tc) and input response time (Tr): $1 / ((2 \times Tc) + Tr)$	In accordance with cycle time (Tc) and input response time (Tr): $1 / ((2 \times Tc) + Tr)$
Sensor type	Contact or 3-wire PNP	Contact or 3-wire PNP
Input type	Resistive	Resistive
Isolation between power supply and inputs	None	None
Isolation between inputs	None	None
Protection against polarity inversions	Yes	Yes
Status indicator	On LCD screen for CD and XD	On LCD screen for CD and XD

Characteristics of relay outputs common to the entire range

Max. breaking voltage	5 → 30 V $\overline{\text{---}}$ 24 → 250 V \sim
Breaking current	CB-CD-XD10-XB10-XR06-XR10: 8 A XD26-XB26: 8 x 8 A relay, 2 x 5 A relay XE10: 4 x 5 A relay XR14: 4 x 8 A relay, 2 x 5 A relay
Electrical durability for 500 000 operating cycles	Utilization category DC-12: 24 V, 1.5 A Utilization category DC-13: 24 V (L/R = 10 ms), 0.6 A Utilization category AC-12: 230 V, 1.5 A Utilization category AC-15: 230 V, 0.9 A
Max. Output Common Current	12 A for O8, O9, OA
Minimum switching capacity	10 mA (at minimum voltage of 12 V)
Minimum load	12 V, 10 mA
Maximum rate	Off load: 10 Hz At operating current: 0.1 Hz
Mechanical life	10.000.000 (operations)
Voltage for withstanding shocks	In accordance with IEC/EN 60947-1 and IEC/EN 60664-1: 4 kV
Response time	Make 10 ms Release 5 ms
Built-in protections	Against short-circuits: None Against overvoltages and overloads: None
Status indicator	On LCD screen for CD and XD

Characteristics of product with DC power supplied

Supply	12 V $\overline{\text{---}}$	24 V $\overline{\text{---}}$
Nominal voltage	12 V $\overline{\text{---}}$	24 V $\overline{\text{---}}$
Operating limits	-13 % / +20 % or 10.4 V $\overline{\text{---}}$ → 14.4 V $\overline{\text{---}}$ (including ripple)	-20 % / +25 % or 19.2 V $\overline{\text{---}}$ → 30 V $\overline{\text{---}}$ (including ripple)
Immunity from micro power cuts	≤ 1 ms (repetition 20 times)	≤ 1 ms (repetition 20 times)
Max. absorbed power	CB12 with solid state outputs: 1.5 W CD12: 1.5 W CD20: 2.5 W XD26-XB26: 3 W XD26-XB26 with extension: 5 W XD26 with solid state outputs: 2.5 W	CB12-CD12-CD20 with solid state outputs - XD10-XB10 with solid state outputs: 3 W XD10-XB10 with relay outputs: 4 W XD26-XB26 with solid state outputs: 5 W CB20-CD20 with relay outputs: 6 W XD26 with relay outputs: 6 W XD10-XB10 with extension: 8 W XD26-XB26 with extension: 10 W
Protection against polarity inversions	Yes	Yes
Digital inputs (I1 to IA and IH to IY)	12 V $\overline{\text{---}}$	24 V $\overline{\text{---}}$
Input voltage	12 V $\overline{\text{---}}$ (-13 % / +20 %)	24 V $\overline{\text{---}}$ (-20 % / +25 %)
Input current	3.9 mA @ 10.44 V $\overline{\text{---}}$ 4.4 mA @ 12.0 V $\overline{\text{---}}$ 5.3 mA @ 14.4 V $\overline{\text{---}}$	2.6 mA @ 19.2 V $\overline{\text{---}}$ 3.2 mA @ 24 V $\overline{\text{---}}$ 4.0 mA @ 30.0 V $\overline{\text{---}}$
Input impedance	2.7 k Ω	7.4 k Ω
Logic 1 voltage threshold	≥ 7 V $\overline{\text{---}}$	≥ 15 V $\overline{\text{---}}$
Making current at logic state 1	≥ 2 mA	≥ 2.2 mA
Logic 0 voltage threshold	≤ 3 V $\overline{\text{---}}$	≤ 5 V $\overline{\text{---}}$
Release current at logic state 0	< 0.9 mA	< 0.75 mA
Response time	1 → 2 cycle times + 6 ms	1 → 2 cycle times + 6 ms
Maximum counting frequency	- Inputs I1 & I2: FBD (up to 6 kHz) & Ladder (1 kHz) - Inputs I3 to IA & IH to IY: In accordance with cycle time (Tc) and input response time (Tr): $1 / ((2 \times Tc) + Tr)$	- Inputs I1 & I2: FBD (up to 6 kHz) & Ladder (1 kHz) - Inputs I3 to IA & IH to IY: In accordance with cycle time (Tc) and input response time (Tr): $1 / ((2 \times Tc) + Tr)$
Sensor type	Contact or 3-wire PNP	Contact or 3-wire PNP
Conforming to IEC/EN 61131-2	Type 1	Type 1
Input type	Resistive	Resistive
Isolation between power supply and inputs	None	None
Isolation between inputs	None	None
Protection against polarity inversions	Yes	Yes
Status indicator	On LCD screen for CD and XD	On LCD screen for CD and XD

Analog or digital inputs (IB to IG)	12 V $\overline{\text{---}}$	24 V $\overline{\text{---}}$
CB12-CD12-XD10-XB10	4 inputs IB \rightarrow IE	4 inputs IB \rightarrow IE
CB20-CD20-XB26-XD26	6 inputs IB \rightarrow IG	6 inputs IB \rightarrow IG
Inputs used as analog inputs only in FBD		
Measurement range	(0 \rightarrow 10 V) or (0 \rightarrow V power supply)	(0 \rightarrow 10 V) ou (0 \rightarrow V power supply)
Input impedance	14 k Ω	12 k Ω
Input voltage	14.4 V $\overline{\text{---}}$ max.	30 V $\overline{\text{---}}$ max.
Value of LSB	14 mV	29 mV
Input type	Common mode	Common mode
Resolution	10 bit at max. input voltage	10 bit at max. input voltage
Conversion time	Controller cycle time	Controller cycle time
Accuracy at 25 °C	\pm 5 %	\pm 5 %
Accuracy at 55 °C	\pm 6.2 %	\pm 6.2 %
Repeat accuracy at 55 °C	\pm 2 %	\pm 2 %
Isolation between analog channel and power supply	None	None
Cable length	10 m maximum, with shielded cable (sensor not isolated)	10 m maximum, with shielded cable (sensor not isolated)
Protection against polarity inversions	Yes	Yes
Potentiometer control	2.2 k Ω / 0.5 W (recommended) 10 k Ω max.	2.2 k Ω / 0.5 W (recommended) 10 k Ω max.
Inputs used as digital inputs		
Input voltage	12 V $\overline{\text{---}}$ (-13 % / +20 %)	24 V $\overline{\text{---}}$ (-20 % / +25 %)
Input current	0.7 mA @ 10.44 V $\overline{\text{---}}$ 0.9 mA @ 12.0 V $\overline{\text{---}}$ 1.0 mA @ 14.4 V $\overline{\text{---}}$	1.6 mA @ 19.2 V $\overline{\text{---}}$ 2.0 mA @ 24.0 V $\overline{\text{---}}$ 2.5 mA @ 30.0 V $\overline{\text{---}}$
Input impedance	14 k Ω	12 k Ω
Logic 1 voltage threshold	\geq 7 V $\overline{\text{---}}$	\geq 15 V $\overline{\text{---}}$
Making current at logic state 1	\geq 0.5 mA	\geq 1.2 mA
Logic 0 voltage threshold	\leq 3 V $\overline{\text{---}}$	\leq 5 V $\overline{\text{---}}$
Release current at logic state 0	\leq 0.2 mA	\leq 0.5 mA
Response time	1 \rightarrow 2 cycle times	1 \rightarrow 2 cycle times
Maximum counting frequency in FBD	In accordance with cycle time (Tc) and input response time (Tr): $1 / ((2 \times Tc) + Tr)$	In accordance with cycle time (Tc) and input response time (Tr): $1 / ((2 \times Tc) + Tr)$
Sensor type	Contact or 3-wire PNP	Contact or 3-wire PNP
Conforming to IEC/EN 61131-2	Type 1	Type 1
Input type	Resistive	Resistive
Isolation between power supply and inputs	None	None
Isolation between inputs	None	None
Protection against polarity inversions	Yes	Yes
Status indicator	On LCD screen for CD and XD	On LCD screen for CD and XD
Characteristics of relay outputs common to the entire range		
Max. breaking voltage	5 \rightarrow 30 V $\overline{\text{---}}$ 24 \rightarrow 250 V \sim	
Max. Output Common Current	12 A (10 A UL) for O8, O9, OA	
Breaking current	CB-CD-XD10-XB10-XR06-XR10: 8 A XD26-XB26: 8 x 8 A relay, 2 x 5 A relay XE10: 4 x 5 A relay XR14: 4 x 8 A relay, 2 x 5 A relay	
Electrical durability for 500 000 operating cycles	Utilization category DC-12: 24 V, 1.5 A Utilization category DC-13: 24 V (L/R = 10 ms), 0.6 A Utilization category AC-12: 230 V, 1.5 A Utilization category AC-15: 230 V, 0.9 A	
Minimum switching capacity	10 mA (at minimum voltage of 12 V)	
Minimum load	12 V, 10 mA	
Maximum rate	Off load: 10 Hz At operating current: 0.1 Hz	
Mechanical life	10.000.000 (operations)	
Voltage for withstanding shocks	In accordance with IEC/EN 60947-1 and IEC/EN 60664-1: 4 kV	
Off-cycle response time	Make 10 ms Release 5 ms	
Built-in protections	Against short-circuits: None Against overvoltages and overloads: None	
Status indicator	On LCD screen for CD and XD	

Digital / PWM solid state outputs	12 V $\overline{\text{---}}$	24 V $\overline{\text{---}}$
PWM solid state outputs*	CB12: O4 XD26: O4 \rightarrow O7	CD12-XD10-XB10: O4 CD20-XD26-XB26: O4 \rightarrow O7
* Only available with "FBD" programming language		
Breaking voltage	10.4 \rightarrow 30 V $\overline{\text{---}}$	19.2 \rightarrow 30 V $\overline{\text{---}}$
Nominal voltage	12-24 V $\overline{\text{---}}$	24 V $\overline{\text{---}}$
Nominal current	0.5 A	0.5 A
Max. breaking current	0.625 A	0.625 A
Voltage drop	\leq 2 V for I = 0.5 A (at state 1)	\leq 2 V for I = 0.5 A (at state 1)
Response time	Make \leq 1 ms Release \leq 1 ms	Make \leq 1 ms Release \leq 1 ms
Frequency (Hz)	1 Maximum on inductive load	1 Maximum on inductive load
Built-in protections	Against overloads and short-circuits: Yes Against overvoltages (*): Yes Against inversions of power supply: Yes (* In the absence of a voltfree contact between the logic controller output and the load	Against overloads and short-circuits: Yes Against overvoltages (*): Yes Against inversions of power supply: Yes (* In the absence of a voltfree contact between the logic controller output and the load
Min. load	1 mA	1 mA
Maximum incandescent load	0.2 A / 12 V $\overline{\text{---}}$ 0.1 A / 24 V $\overline{\text{---}}$	0.1 A / 24 V $\overline{\text{---}}$
Galvanic isolation	No	No
PWM frequency	14.11 Hz 56.45 Hz 112.90 Hz 225.80 Hz 451.59 Hz 1806.37 Hz	14.11 Hz 56.45 Hz 112.90 Hz 225.80 Hz 451.59 Hz 1806.37 Hz
PWM cyclic ratio	0 \rightarrow 100 % (256 steps for CD, XD and 1024 steps for XA)	0 \rightarrow 100 % (256 steps for CD, XD and 1024 steps for XA)
PWM accuracy at 120 Hz	< 5 % (20 % \rightarrow 80 %) load at 10 mA	< 5 % (20 % \rightarrow 80 %) load at 10 mA
Max. Breaking current PWM	50 mA	50 mA
Max. cable length PWM	20 m	20 m
PWM accuracy at 500 Hz	< 10 % (20 % \rightarrow 80 %) load at 10 mA	< 10 % (20 % \rightarrow 80 %) load at 10 mA
Status indicator	On LCD screen for CD and XD	On LCD screen for CD and XD

Differences between Millenium 3 Smart and Millenium 3 Essential



Millenium 3 Smart	
Display	Blue, backlit with white text
Supply versions	24 V $\overline{\text{---}}$, 12 V $\overline{\text{---}}$, 100 \rightarrow 240 V \sim , 24 V \sim
Operating Temperature	-20 \rightarrow +70 °C/-4 \rightarrow +158 °F (+40 °C/104 °F in non-ventilated enclosure), except CB, XB in $\overline{\text{---}}$: -30 \rightarrow +70 °C/-22 \rightarrow +158 °F (+40 °C/104 °F in non-ventilated enclosure) in accordance with IEC/EN 60068-2-1 and IEC/EN 60068-2-2
Storage temperature	-40 \rightarrow +80 °C (-40 \rightarrow +176 °F) in accordance with IEC/EN 60068-2-1 and IEC/EN 60068-2-2
More extensions	- XN07 extension for inter-Millenium 3 communication (up to 7 Millenium) - XA03 extension (3 analog inputs for Pt100 temperature probes)
More sensors	Direct connection of NTC temperature probes and LDR luminosity sensors
More functions	Additional application specific functions: Autotuning PID, Astronomical clock, Transfer function $y=f(x)$, 2 axis solar tracking, ...
Number of function blocks in the library	125

Millenium 3 Essential	
Display	Green, backlit with black text
Supply versions	24 V $\overline{\text{---}}$, 12 V $\overline{\text{---}}$
Operating Temperature	-20 \rightarrow +55 °C/-4 \rightarrow +131 °F (+40 °C/104 °F in non-ventilated enclosure) in accordance with IEC/EN 60068-2-1 and IEC/EN 60068-2-2
Storage temperature	-40 \rightarrow +70 °C (-40 \rightarrow +158 °F) in accordance with IEC/EN 60068-2-1 and IEC/EN 60068-2-2
More extensions	
More sensors	
More functions	
Number of function blocks in the library	105